

STANLEY[®]
MAGIC-DOOR

MAGIC-SWING[®]

Swing Door Operator

Installation and Tune-In
Manual

#203585-5/92

GENERAL INFORMATION

POWER REQUIRED—117 V.A.C. 15 AMP. SERVICE FOR 1-2 OPERATORS
DEDICATED 20 AMP. SERVICE FOR 3-4 OPERATORS

IN-HEADER

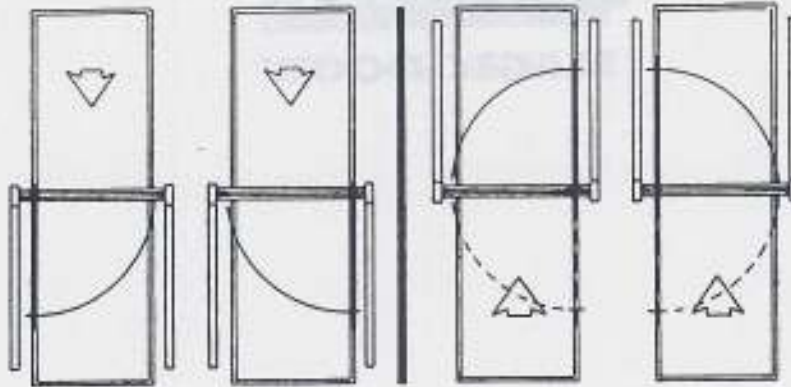

- A. Door must be double swing
- B. Door must have min. $\frac{5}{8}$ " top web. $\frac{1}{2}$ " min. bottom web.
- C. Pivot center must be $3\frac{3}{4}$ "

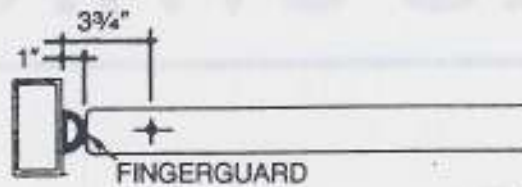

- D. Door must be rear mounting

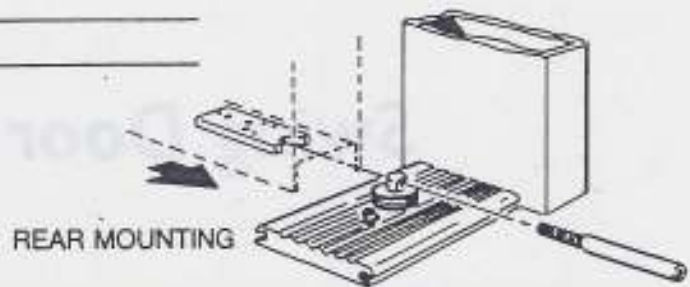

VISIBLE

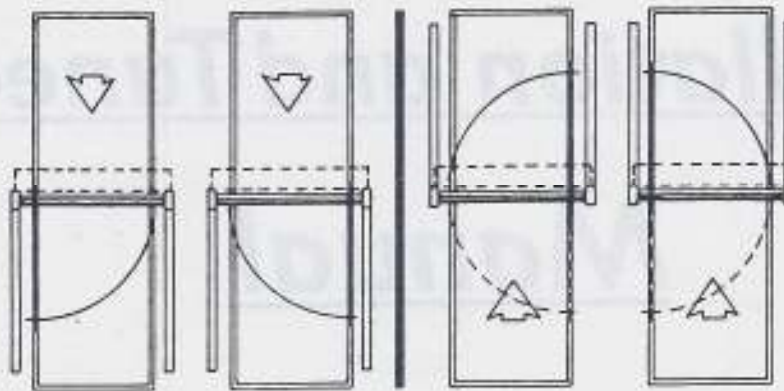

In applications require the following side clearance for proper 90° swing.

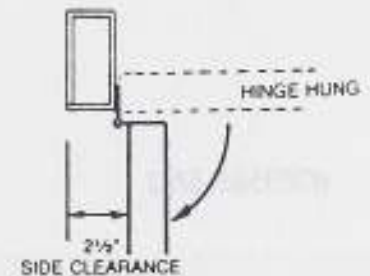
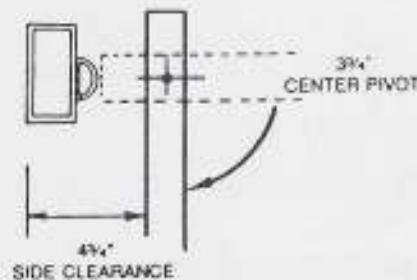
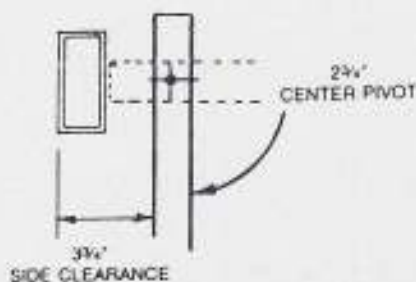

HEADER INSTALLATION

Locate bottom of header on jambs. Jambs must be vertical, parallel. Bottom of header is determined by adding mat thickness plus clearance plus door height plus clearance.

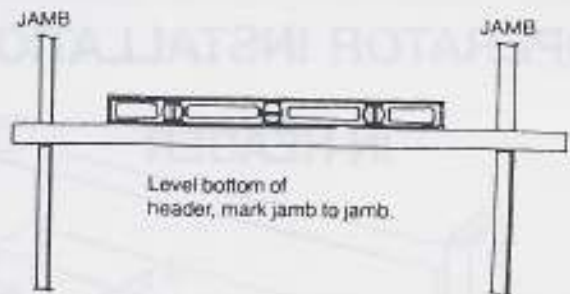

NOTE: Header must be level for proper operation of door.

IN-HEADER

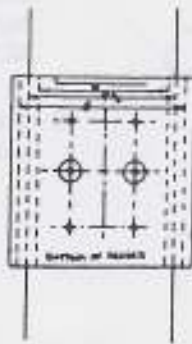
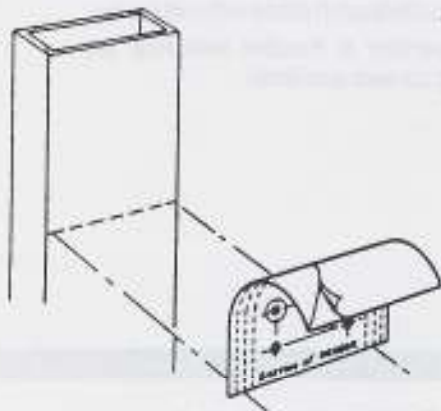

Remove backing and apply to jamb. Be sure to align bottom of template with bottom of header line already marked on jamb. NOTE: Be sure to align dotted lines on template to your jamb width.

Drill holes in jamb through template as indicated.

NOTE: The 1" hole is drilled in the jamb opposite the pivot.

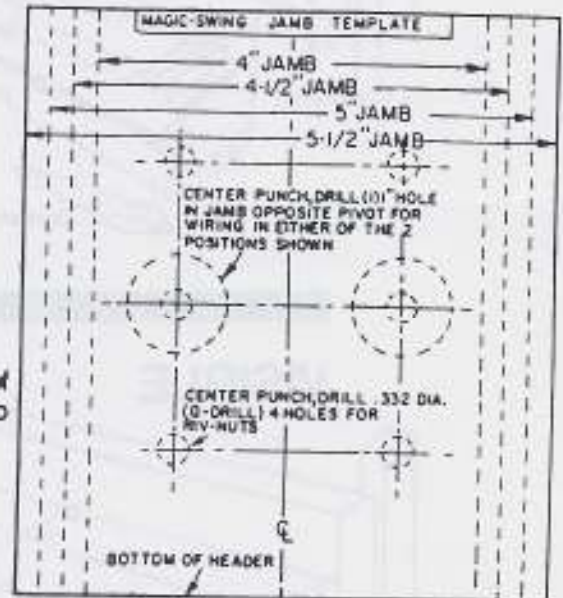

VISIBLE

Mount the header 1 1/4" up from the lowest point on the header support.

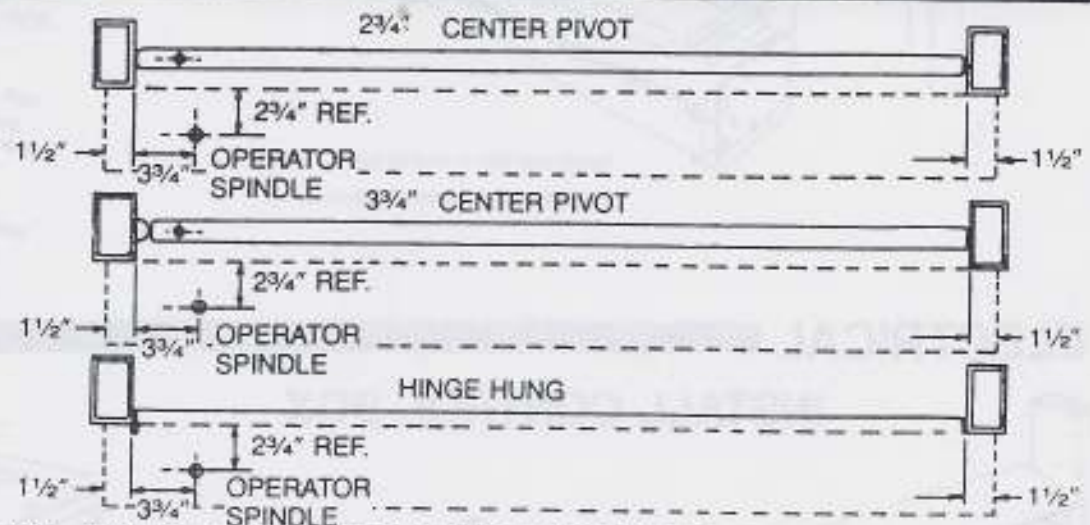

FOR ALL TYPES OF DOOR APPLICATIONS THE HEADER MUST MEASURE 3" LARGER THAN THE DOOR OPENING WIDTH. THIS PROVIDES 1 1/2" OVERLAP ON BOTH JAMBS WHICH IS USED FOR MOUNTING.

USE OF RIV-NUTS

1. Locate mounting holes using the header as a template.
2. Drill (4) holes with Q drill and insert riv-nuts.
3. Secure header to jamb with 1/4-20 screws provided.

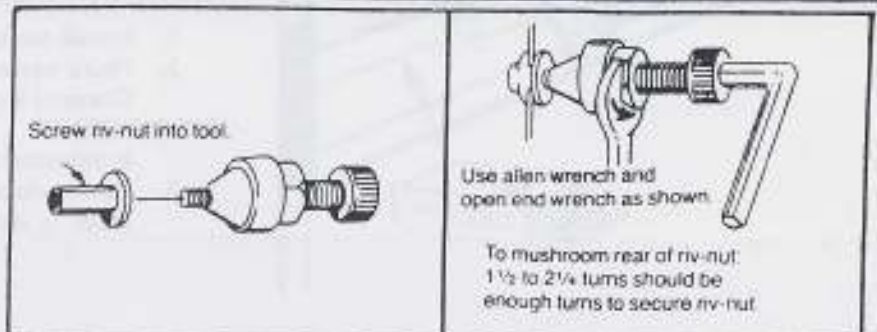

OPERATOR INSTALLATION

IN-HEADER

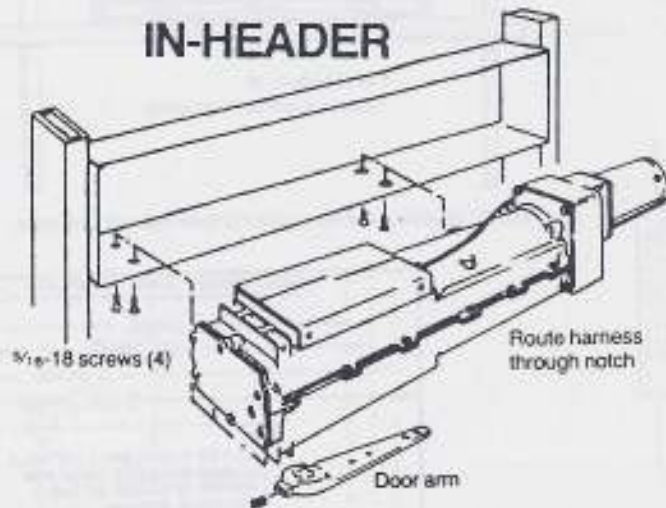

1. Secure door arm to operator. Door arm must be flush with bottom of spindle.
NOTE: Door arm must be set to 0° position and locked in place with set screw.
2. Install operator in header with four (4) mounting screws provided.

VISIBLE

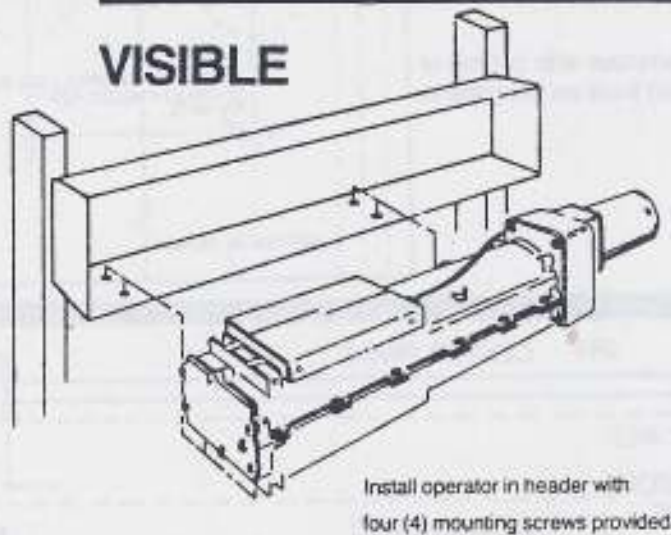

For IN applications only

1. Remove operator end cap.
2. Install space block and two gaskets as shown.
3. Re-install end cap with six longer screws provided.
4. Be certain end cap is correctly oriented for hand of operator.

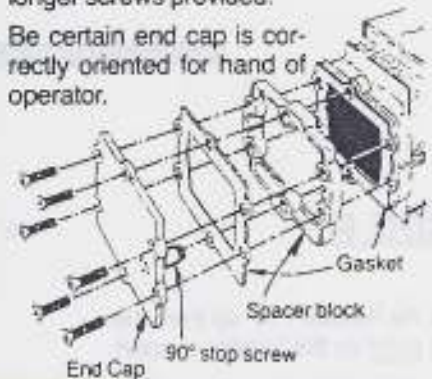

ELECTRICAL INSTALL CONTROL BOX

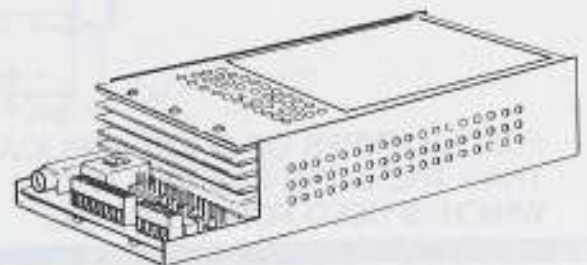
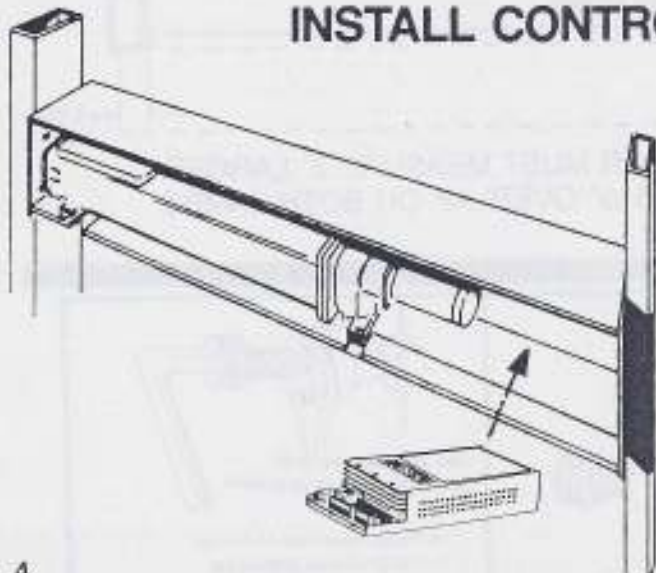

1. Install control box.
 2. Make necessary connections. (Consult Microprocessor Control Box instructions #203821.)
- IMPORTANT:** Do not turn operator on until the 90° stop is adjusted as shown in the "Tune-In" section.
3. Power door open by shorting the yellow and orange leads to each other on the control connector.

INSTALL ON-OFF-HOLD OPEN SWITCH

1. Locate on-off-hold open switch on jamb opposite pivot.
2. Drill 1-1/4" dia. hole as shown.
3. Feed wires through the jamb.
4. Insert on-off-hold open switch and secure with screws provided.
5. Attach wires to control box as shown in Microprocessor Control Box instruction manual #203821.

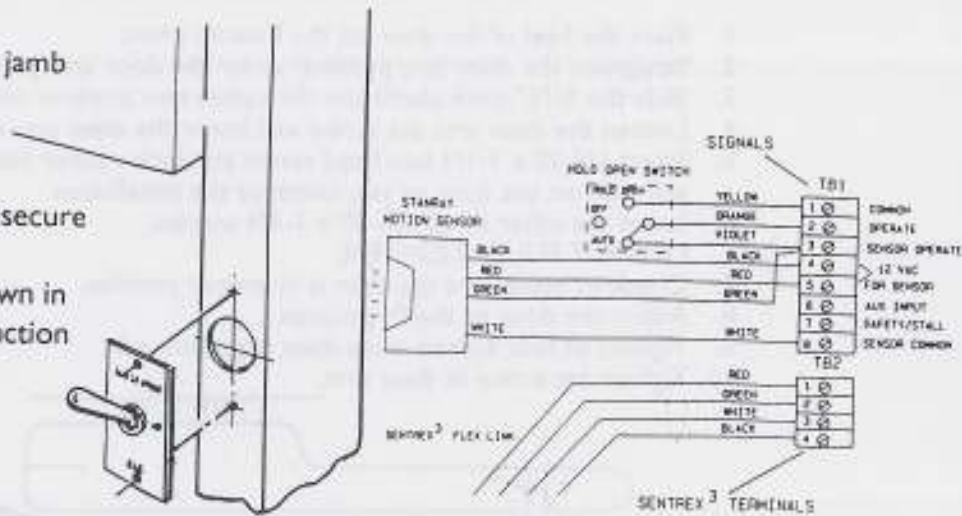

IN-HEADER DOOR PREPARATION

DETAIL OF TOP DOOR ARM 311652

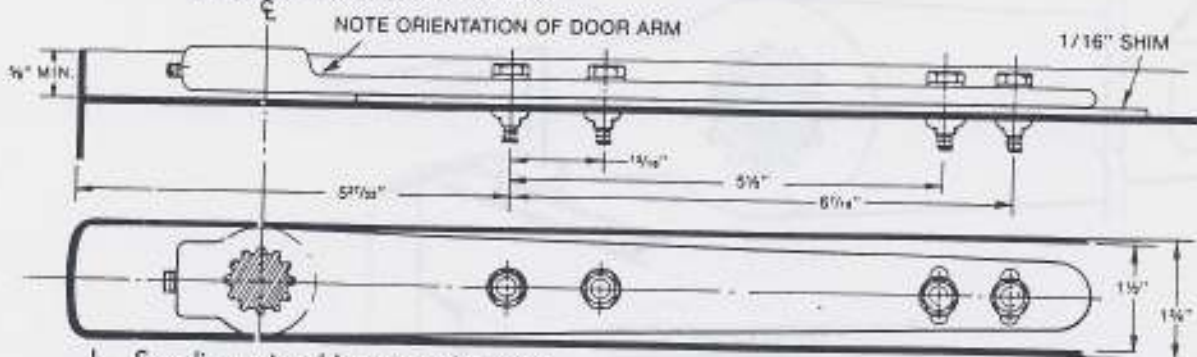

1. See dimensional locations for holes.
2. Drill (4) .332 dia. ("Q" drill) holes previously located.
3. Insert the 1/4-20 steel riv-nuts provided. Make sure they are properly seated.

WARNING - DO NOT SUBSTITUTE ALUMINUM RIV-NUTS.

NOTE: A) Long riv-nut for 1/4" thick top web. B) Short riv-nut for 1/8" thick top web.

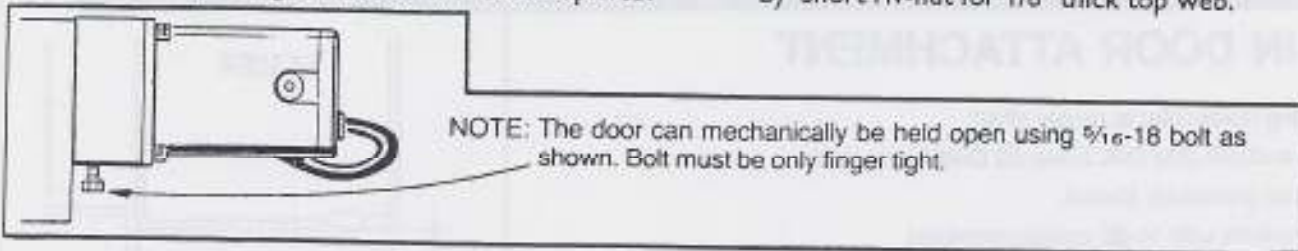

MOUNT BOTTOM PIVOT AND THRESHOLD

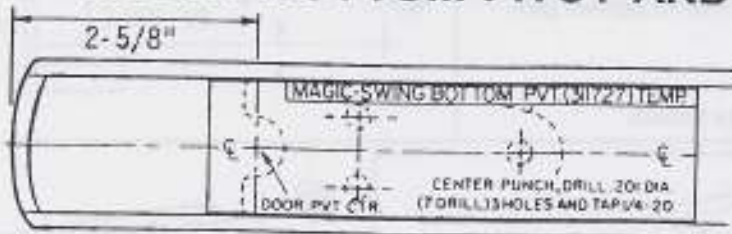

1. Remove backing from bottom pivot template. Apply to bottom web of door as shown.
2. Template door pivot, must be located on door properly.
3. Drill and tap 3 holes for 1/4-20 screws provided.
4. Position threshold centerline on centerline of jamb. Centerline of pivot must be 3 3/4" away from jamb. Mark screw holes, drill and fasten to floor.

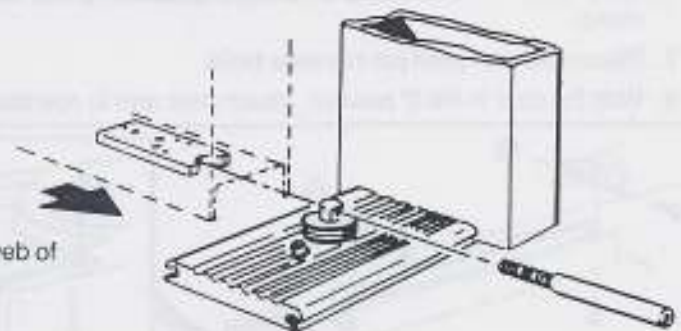

IN HEADER

1. Place the heel of the door on the bottom pivot.
2. Straighten the door into position under the door arm previously attached to the operator.
3. Slide the 1/16" thick aluminum shim plate into position over the riv-nut heads.
4. Loosen the door arm set screw and lower the door arm onto the shim plate.
5. Insert 1/4-20 x 1-1/4 hex head screw and lock washer into the hole nearest the pivot. This screw will support the door as you continue the installation.
6. Insert the other three 1/4-20 x 1-1/4 screws.
- DO NOT FULLY TIGHTEN.
7. Check to make sure the shim is in proper position.
8. Adjust the door to the 0° position.
9. Tighten all four screws once door is positioned.
10. Tighten set screw in door arm.

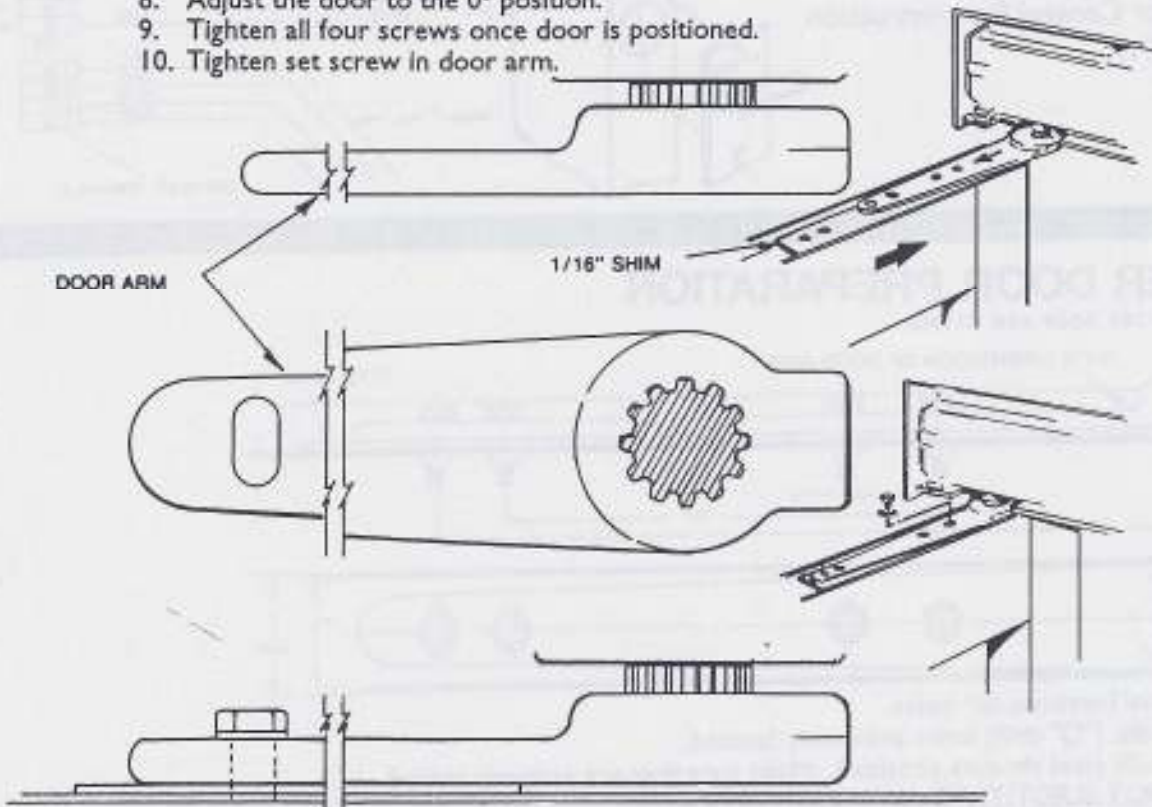

VISIBLE IN DOOR ATTACHMENT

1. Locate mounting holes refer to proper chart.
2. Center punch and drill .332 DIA. holes (Q Drill) for riv-nuts.
3. Install riv-nuts as previously shown.
4. Secure end brackets with 1/4-20 screws provided.
5. Insert slide block.
6. Snap track into end blocks as shown. Secure in place with 3/16-18 screws provided.
7. Place door arm pivot pin into slide block.
8. With the door in the 0° position, attach door arm to operator as shown.

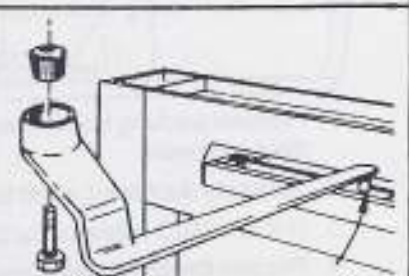
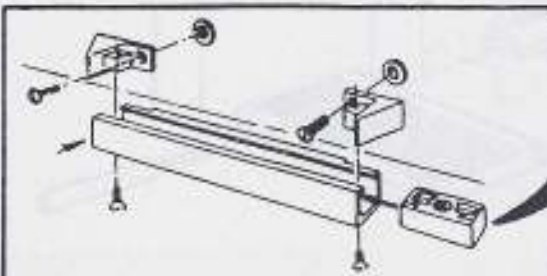
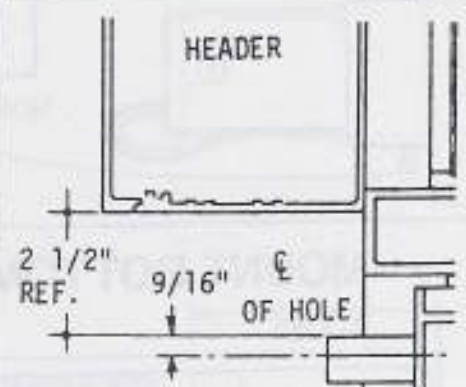

TABLE OF CONTENTS

	Page
Tune-in Manual	2
Troubleshooting Manual	3
Repair Manual	8
Electrical Schematic — Operator Switch Box	14
Replacement Parts Exploded Diagram	15
Replacement Parts List	17

STANLEY MAGIC SWING OPERATOR

STANLEY

Helps you do things right.

TUNE-IN TROUBLESHOOTING REPAIR

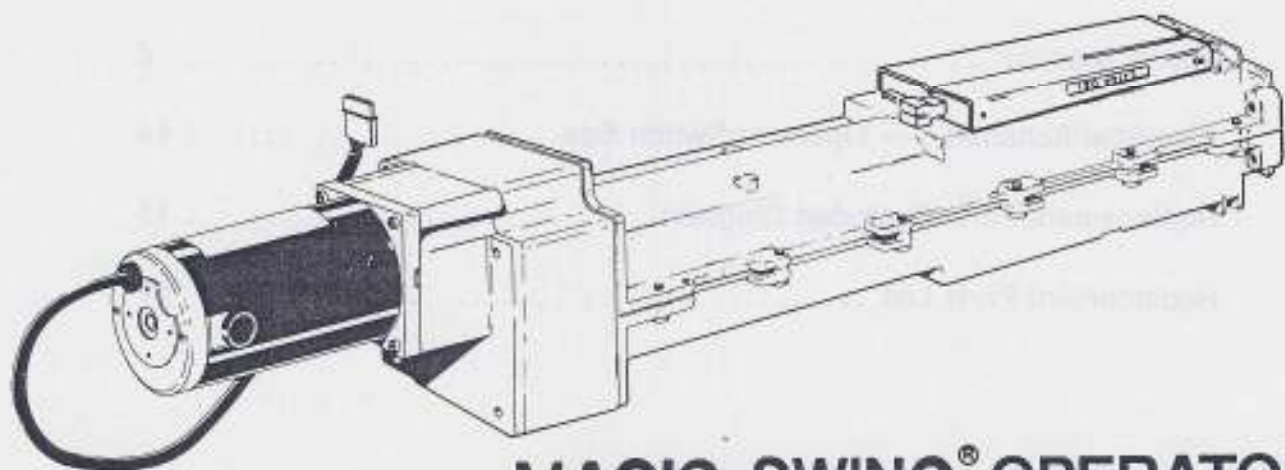

MAGIC-SWING® OPERATOR

STANLEY MAGIC-DOOR

STANLEY

helps you do things right.®

TUNE-IN and ADJUSTMENT

DOOR ADJUSTMENT—90° POSITION

Open the door manually until you feel the operator reach its internal stop. Determine how much more or less travel is required for proper 90° operation.

To make 90° position adjustment with the operator in the header, drill a 1" hole in the end cap in line with the stop screw, or remove the header end plate.

NOTE: Once the stop screw has been adjusted, you may have to adjust the opening check switch cam to obtain the recommended 15° of checking action.

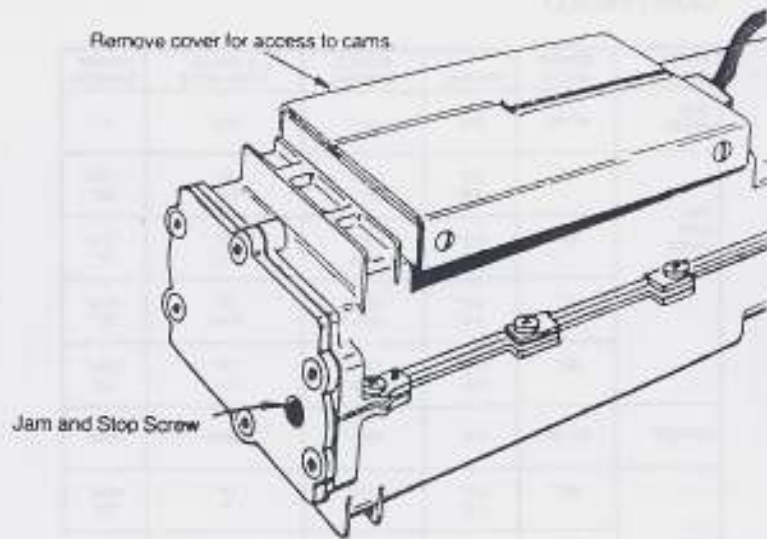

Remove jam screw from stop screw hole. Adjust stop screw in to reduce or out to increase door opening. 1/2 turn of stop screw will move edge of 42" door 1". Reinstall jam screw and tighten hard against stop screw.

* **MICROPROCESSOR CONTROL BOX** - Open check switch and cam are not used, open check is calculated by the control box and motor encoder. This switch and cam can be used for other door functions if necessary (ie) door status switch.

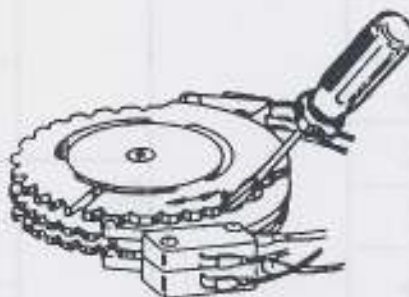
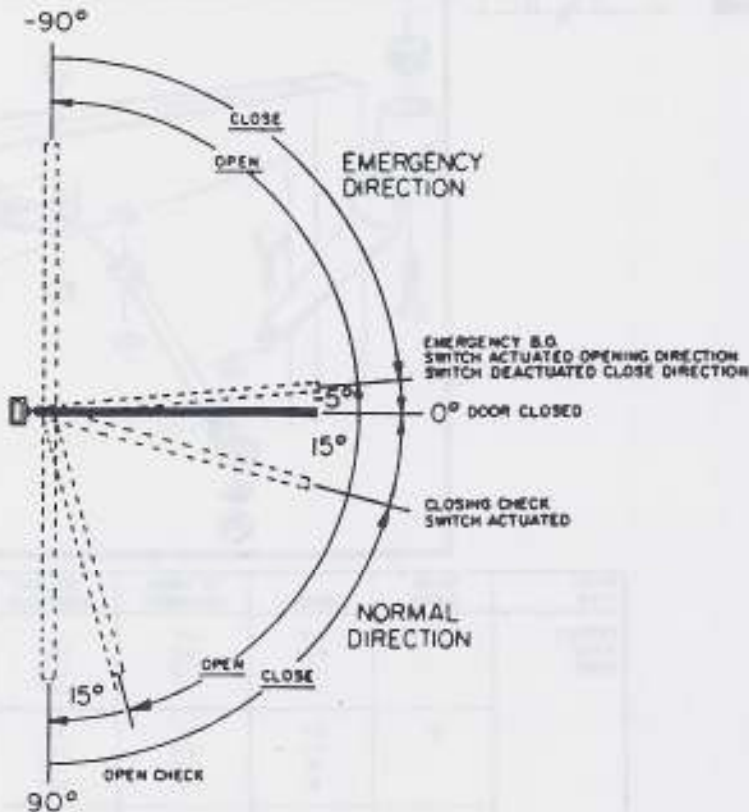

Adjust cams if necessary—cams may be adjusted with a screwdriver as shown. It is not necessary to loosen screw to adjust cams.

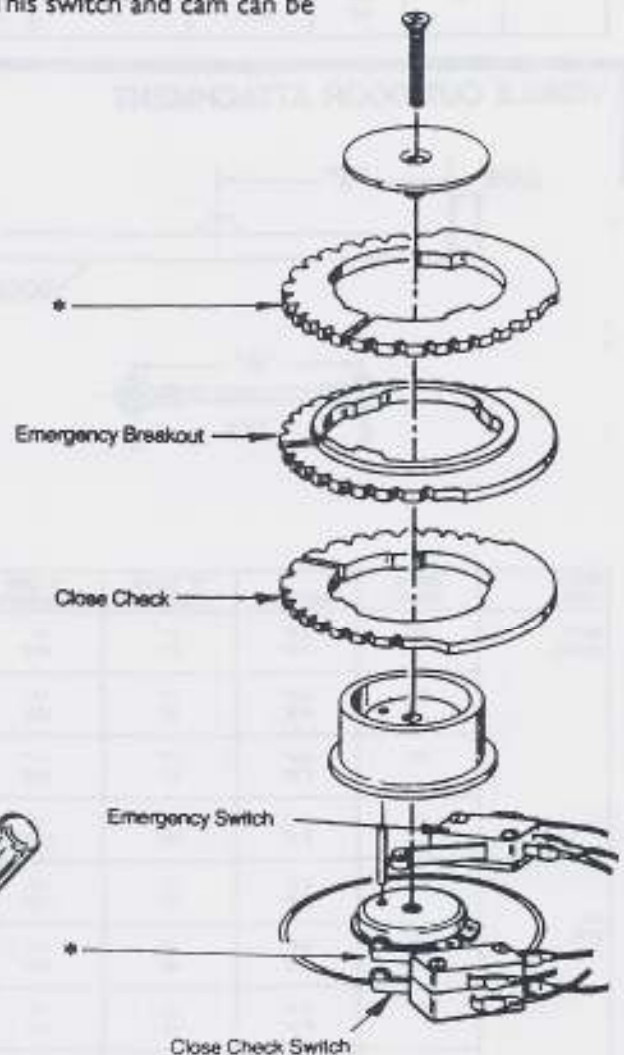

R.H. Shown

IN DOOR ATTACHMENT CONTINUED

PIVOT TYPE	DOORS WIDTH	REVEAL	D HOLE SPACING	X DIM TO FIRST HOLE	TRACK LENGTH
BUTT HUNG	37"-44"	0-6"	13 1/4"	12 1/4"	15 1/4"
2 1/2% CTR PIVOT	32"	0-2" 3-6"	13 1/4" 20 1/4"	10" 6 1/2"	15 1/4" 23"
	36"	0-2" 3-6"	13 1/4" 20 1/4"	10" 6 1/2"	15 1/4" 23"
	42"	0-2" 3-6"	13 1/4" 20 1/4"	10" 6 1/2"	15 1/4" 23"
	44"	0-2" 3-6"	13 1/4" 20 1/4"	10" 6 1/2"	15 1/4" 23"
OFFSET	32"-44"	0-6"	13 1/4"	12 1/4"	15 1/4"
3 1/2% CTR PIVOT	32"	0-2" 3-6"	13 1/4" 20 1/4"	11" 7"	15 1/4" 23"
	36"	0-2" 3-6"	13 1/4" 20 1/4"	11" 7"	15 1/4" 23"
	42"	0-2" 3-6"	13 1/4" 20 1/4"	11" 7"	15 1/4" 23"
	44"	0-2" 3-6"	13 1/4" 20 1/4"	11" 7"	15 1/4" 23"

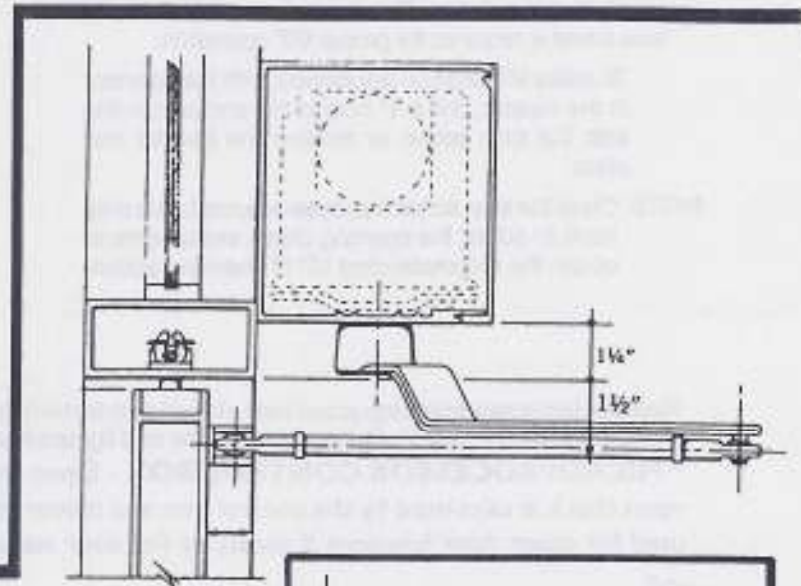

VISIBLE OUT DOOR ATTACHMENT

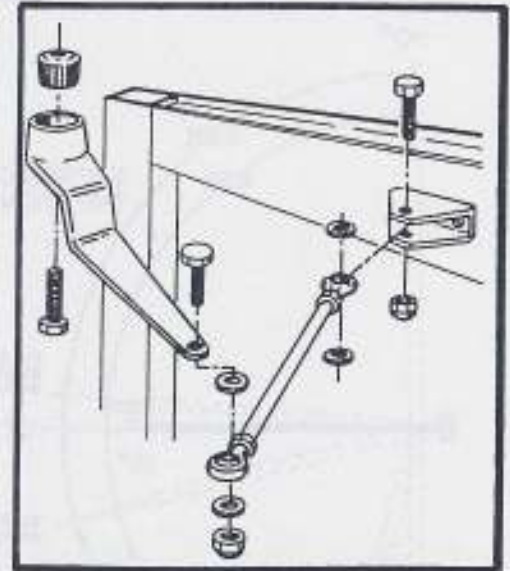
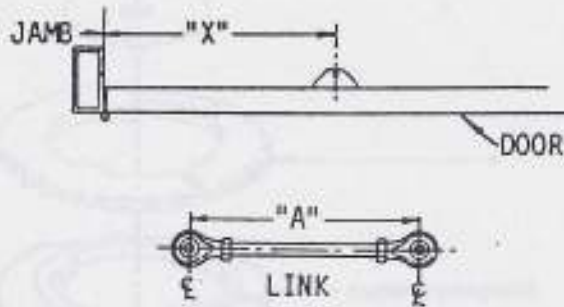

PIVOT TYPE	DOOR WIDTH	REVEAL	"X" DOOR DIMENSION	"A" LINK DIMENSION
BUTT HUNG	32"	0-3" 4'-8"	11" 11"	11" 12.5"
	36"	0-3" 4'-8"	11" 11"	11" 12.5"
	42"	0-4" 5'-8"	11" 11"	11" 12.5"
	44"	0-4" 5'-8"	11" 11"	11" 12.5"
2 1/2% CTR PIVOT	32"	0-5" 6'-8"	15" 15"	11" 12.5"
	36"	0-5" 6'-8"	15" 15"	11" 12.5"
	42"	0-5" 6'-8"	15" 15"	11" 11"
	44"	0-5" 6'-8"	15" 15"	11" 12.5"
OFFSET PIVOT	32"	0-3" 4'-8" 7" 8"	11" 12.5" 11.5" 11"	11" 12.5" 12.5" 12.5"

PIVOT TYPE	DOOR WIDTH	REVEAL	"X" DOOR DIMENSION	"A" LINK DIMENSION		
OFFSET PIVOT CONT.	36"	0-3" 4'-6" 7" 8"	11" 12.5" 11.5" 11"	11" 12.5" 12.5" 12.5"		
		42"	0-3" 4'-6" 7" 8"	11" 12.5" 11.5" 11"	11" 12.5" 12.5" 12.5"	
			44"	0-3" 4'-6" 7" 8"	11" 12.5" 11.5" 11"	11" 12.5" 12.5" 12.5"
				3 1/2% CTR PIVOT	32"	0-7" 8"
36"	0-7" 8"				17" 16"	12.5" 12.5"
42"	0-7" 8"	17" 16"			12.5" 12.5"	
44"	0-7" 8"	17" 16"	12.5" 12.5"			

TUNE-IN and ADJUSTMENT

DOOR ADJUSTMENT—90° POSITION

Open the door manually until you feel the operator reach its internal stop. Determine how much more or less travel is required for proper 90° operation.

To make 90° position adjustment with the operator in the header, drill a 1" hole in the end cap in line with the stop screw, or remove the header end plate.

NOTE: Once the stop screw has been adjusted, you may have to adjust the opening check switch cam to obtain the recommended 15° of checking action.

Remove cover for access to cams

Jam and Stop Screw

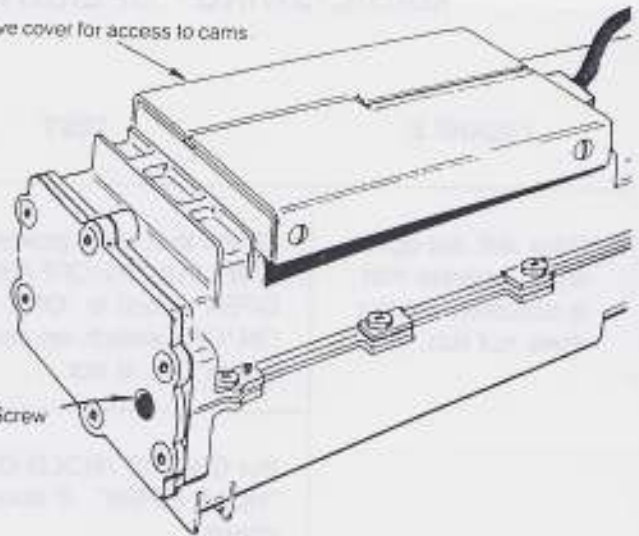

Remove jam screw from stop screw hole. Adjust stop screw in to reduce or out to increase door opening. 1/2 turn of stop screw will move edge of 42" door 1". Reinstall jam screw and tighten hard against stop screw.

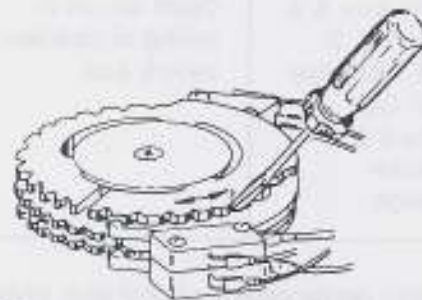
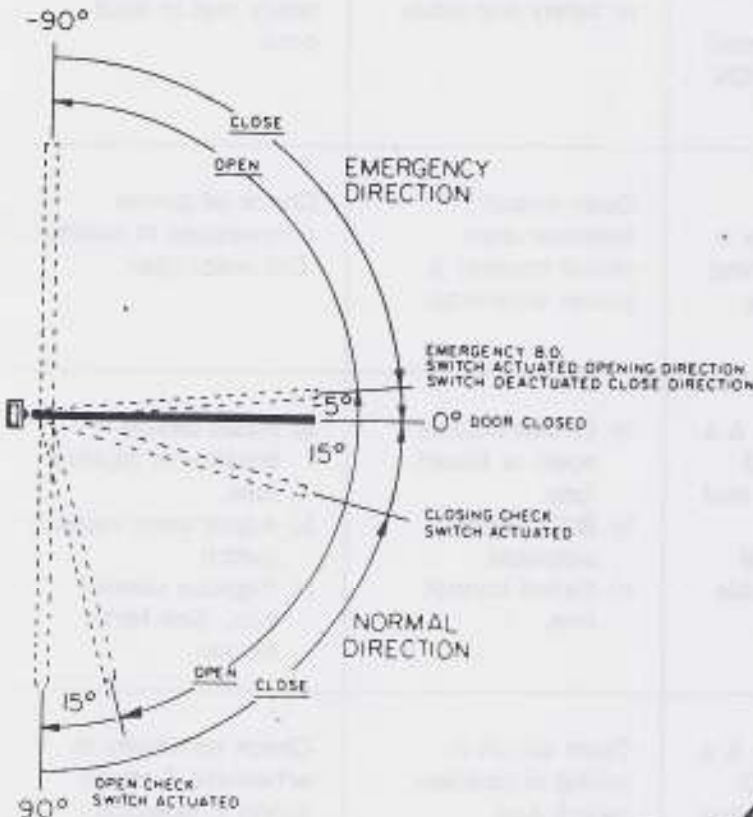

Adjust cams if necessary—cams may be adjusted with a screwdriver as shown. It is not necessary to loosen screw to adjust cams

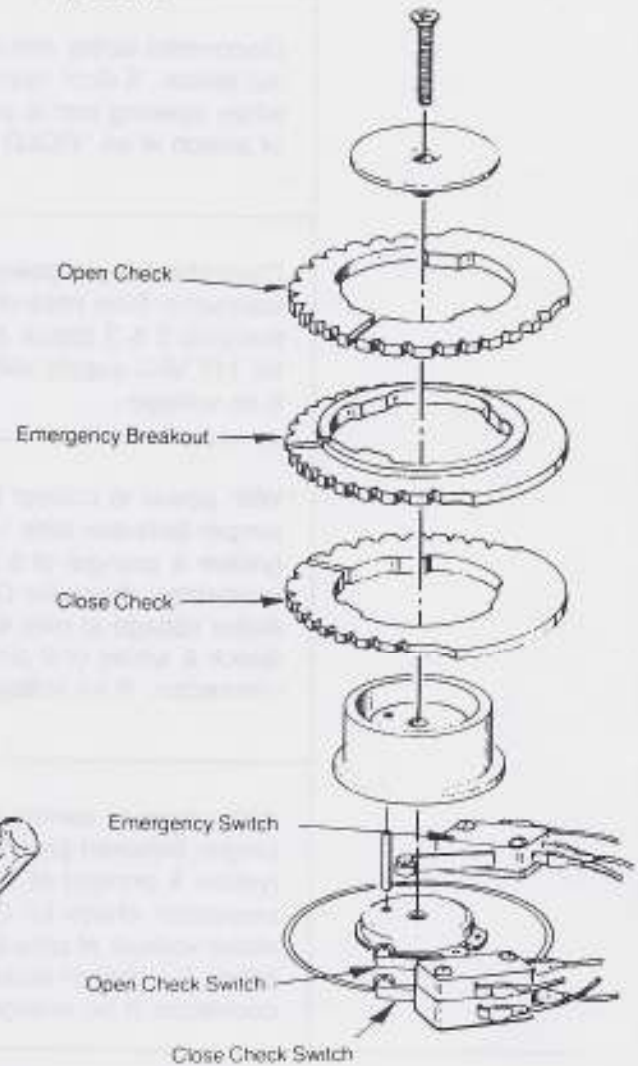

R.H. Shown

MAGIC-SWING® OPERATOR TROUBLESHOOTING MANUAL

TROUBLE	TEST	CAUSE	REMEDY
1) Door will not open when operate mat is actuated. Motor does not run.	Check that main power is "ON", that ON/OFF/HOLD OPEN switch is "ON"; that ON/OFF switch on control box is ON. If not . . .	No power to operator.	Put all switches in ON position.
	Put ON/OFF/HOLD OPEN on "HOLD OPEN". If door now opens . . .	Open operate mat lead cord connection, broken lead cord.	Repair lead cord or replace mat.
	Disconnect safety mat at wire nut splice. If door opens when opening mat is actuated or switch is on "HOLD OPEN" . . .	Shorted safety mat or safety mat leads.	Repair or replace safety mat or lead cord.
	Disconnect 3-pin power connector from control box & test pins 2 & 3 (black & white) for 117 VAC supply voltage. If no voltage . . .	Open circuit between main circuit breaker & power connector.	Check all power connections in header. Call electrician.
	With power to control box & a jumper between pins 1 & 2 (yellow & orange) of 6 pin mat connector, check for DC motor voltage at pins 6 & 8 (black & white) of 9 pin cable connector. If no voltage . . .	a) Circuit breaker open or blown fuse. b) B/O switch actuated. c) Failed control box.	a) Reset circuit breaker or replace fuse. b) Adjust cam; replace switch. c) Replace control box. See Note below.
	With power to control box & a jumper between pins 1 & 2 (yellow & orange) of 6 pin mat connector, check for DC motor voltage at pins 2 & 3 (black & white) of motor connector. If no voltage . . .	Open circuit in wiring of operator switch box.	Check continuity to schematic & repair wiring in operator switch box or replace operator.

NOTE: Before replacing failed control box with replacement control box, check all pins in 9 pin connector on operator switch box for earth ground. Pin 1 only should show earth ground. If any other pins show earth ground, locate grounding point and repair or replace operator.

TROUBLE

TEST

CAUSE

REMEDY

1) continued	If there is DC voltage to motor . . .	Faulty motor	a) Replace motor brushes, Repair Manual b) Replace motor. Repair Manual, 1.
Door will not open when operate mat is accuated. Motor runs.	Check that motor coupling set screw is tight through access hole on underside of motor & gear housing . . .	Loose coupling set screw.	Loctite & tighten set screw, Repair Manual, 2.
	Remove 5 screws holding motor & gear housing to main housing. Examine gears for broken teeth.	Broken gear.	Replace gears, Repair Manual A.
2) Door opens, but has no open check.	Remove cam cover & check that open check cam is actuating switch. If not . . .	Failure to actuate switch.	Adjust cam.
	With ohmmeter, check action of open check switch at pins 3 & 5 (orange & brown) of connector in switch box. If no action . . .	Switch is broken.	Repair switch, Repair Manual, 10.
	If cam & switch action are correct, but there is still no open check.	Faulty control box.	Replace control box, See Note 1.
3) Door opens, goes into open check, but bangs rail or hits wall.	Determine if door is opening to 90 degrees; if not . . .	Stop set screw not properly adjusted.	Adjust stop screw.
	Examine end cap for looseness or leaking grease.	End cap loose or broken.	If loose, tighten screws in end cap, if broken, replace. Repair Manual 7.

TROUBLE	TEST	CAUSE	REMEDY
4) Door opens but opening check slightly too fast or too slow.	Not applicable	Nature of the operator and/or setting of open damp adjustment.	Control Box I — some control available on open damp control trim pot. See Fig. 1. Control Box II complete control available on open damp control pot. See Fig. 2.
5) Door opens, but will not close.	Disconnect operate mat at wire nut. If door now closes . . .	Shorted operate mat.	Locate short & repair or replace mat.
	With power off, manually push door in open and emergency directions. Check for mechanical binding. If there is binding . . .	a) Door dragging. b) Internal mechanical binding in operator.	a) Adjust door. b) Repair operator, Repair Manual, 6, or replace operator.
6) Door opens normally; closes, but has no closing check.	See No Open Check, 2).	Same as above.	Same as above.
7) Door opens partly, but will not open fully; or door opens fully but will not close fully.	Turn power off. Push door open manually. Determine if obstruction is: a) in the door, or b) in the operator.	a) Door sagging. b) Internal mechanical binding in operator.	a) Adjust door. b) Repair operator, Repair Manual, 6, or replace operator.
8) Door closes not fully or too far and opens too far or not fully.	Visible mount . . .	Locking hub has turned in door arm.	Remove locking hub from door arm; reposition & retighten.
	Concealed mount. Put switch on "HOLD OPEN". Check door arm-spindle set screw & door arm lock screw. If either is not tight . . .	Screw has loosened.	Adjust door arm if necessary, and tighten screw.

TROUBLE	TEST	CAUSE	REMEDY
9) Door opens correctly, but closes very rapidly.	If there is closing check, remove operator from header, remove cam covers, inspect resistor.	Loose or broken closing control resistor.	Fasten or replace resistor, Repair Manual, 9.
10) Grease is leaking from operator.	Check condition of gaskets between motor & gear housing & main housing, & between end cap & main housing.	Broken or displaced gaskets.	Replace gasket, Repair Manual, 4 & 7 - or replace operator.
11) On hold open, door creeps closed from full open.	"HOLD OPEN" voltage too low.	Remove cover of control box & adjust "HOLD OPEN" voltage pot. See Figs. 1 & 2.
12) Door opens too fast or too slowly.	Nature of the operator or adjustment of speed control pot.	Control Box I - some control available on speed control trim pot. See Fig. 1. Control Box II - complete control available on speed control pot. See Fig. 2.
13) Door closes slightly too fast or too slowly.	Variation in value of closing speed.	None
14) More time delay needed in open position.	Control Box I - no time delay in control box, add external time delay p/n 514466. Control Box II -adjust time delay control. See Fig. 2 -next page.

Control Box I

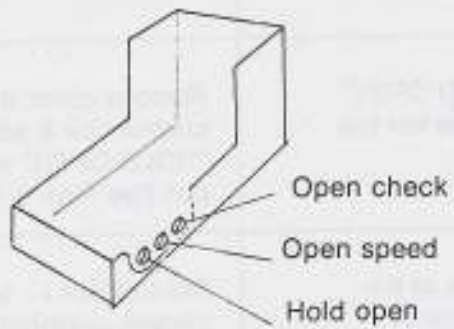

Figure 1

Control Box II

(To replace Control Box I in late 1983)

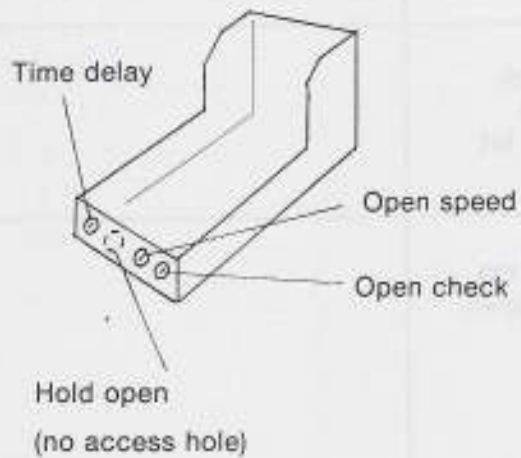

Figure 2

MAGIC-SWING® OPERATOR REPAIR MANUAL

Caution: Operator must always be disconnected from any electric power source before any repairs are attempted.

REPAIR OR REPLACE

PROCEDURE

- | REPAIR OR REPLACE | PROCEDURE |
|---|--|
| 1. Replace motor. | <ol style="list-style-type: none">Unplug motor lead from operator switch box.Remove four screws holding motor to gear housing.Remove motor.Loosen set screw and remove coupling half from shaft. Note - it may be necessary to heat coupling half as set screw is held in place with Loctite.Clean old Loctite from set screw and tapped hole; reapply Loctite, Grade 242 (medium), to set screw; install coupling half on shaft of replacement motor and fasten new motor in place on gear housing with four screws. Note - be sure elastic coupling piece is in place.Plug motor lead into operator switch box. |
| 2. Reset loose coupling. | <ol style="list-style-type: none">Repeat steps a, b, and c above.Determine which coupling half is loose, motor or spur gear half.Remove coupling half; remove set screw as in (d) above; reset set screw and reinstall coupling half as in (e) above.Plug motor lead into operator switch box. |
| 3. Replace spindle/bearing/
seal assembly. | <ol style="list-style-type: none">Unplug motor lead from operator switch box.Remove motor from motor and gear housing by removing 4 screws.Remove 5 screws and remove motor and gear housing assembly from main housing assembly.Remove snap ring which retains bearing in motor and gear housing. |

REPAIR OR REPLACE

PROCEDURE

- e. In an arbor press, press spindle/bearings/seal assembly out of motor and gear housing, pressing **towards** the motor end.
- f. Remove coupling half from spindle (see 1d).
- g. Fasten coupling half to replacement spindle (see 1e).
- h. In an arbor press, press spindle assembly into motor and gear housing. Note - apply press force to end of spindle, not to coupling half.
- i. Reinstall snap ring.
- j. Reinstall motor and gear housing to main housing, and motor to motor and gear housing.
- k. Plug motor lead into operator switch box.

4. Replace motor and gear housing/main housing gasket.

- a. Unplug motor lead form operator switch box.
- b. Remove 5 screws and remove motor and gear housing assembly from main housing assembly.
- c. Remove old gasket and replace with new. Note - examine mating housing surfaces for gouges, and if any are found, replace entire operator.
- d. Reinstall motor and gear housing. Note - be certain change gear and its thrust bearings are correctly assembled on change gear shaft.
- e. Plug motor lead into operator switch box.

5. Replace gears.

- a. Unplug motor lead from operator switch box.
- b. Remove 5 screws and remove motor and gear housing assembly from main housing assembly.
- c. Remove change gear and thrust bearings.
- d. Disengage prong of bearing lock washer from slot in bearing lock nut.

REPAIR OR REPLACE

PROCEDURE

	<ul style="list-style-type: none"> e. Remove bearing lock nut, bearing lock washer, and screw gear. Screw gear key may be left in place. f. Clean grease from motor and gear housing cavity. g. Install new screw gear on shaft and screw gear key; reinstall lock washer and lock nut and tighten lock nut firmly; bend appropriate prong of lock washer into slot of lock nut. h. Install new change gear with thrust bearings correctly placed in support in main housing. i. Apply grease liberally to gears and bearings. j. Reassemble motor and gear housing assembly to main housing. Note - use new gasket. k. Plug motor lead into operator switch box.
<p>6. Replace parts contained in main housing, includes:</p> <ul style="list-style-type: none"> — thrust bearing, washers & collar — spring & screw support — ball screw, spring & rack assembly <p>Note: Only remove parts necessary to reach failed part.</p>	<ul style="list-style-type: none"> a. Unplug motor lead from operator switch box. b. Remove 5 screws and remove motor and gear housing assembly from main housing assembly. c. Remove change gear and thrust bearings. d. Disengage prong of bearing lock washer from slot in bearing lock nut. e. Remove bearing lock nut, bearing lock washer, screw gear and screw gear key. f. Remove thrust bearing collar, washer, bearing and washer (Note order). g. Using snap ring pliers, remove beveled snap ring. CAUTION - do not attempt to remove snap ring without correct snap ring pliers. h. Remove spring and screw support, slide off ball screw shaft. i. Remove thrust bearing washer, bearing, washer & collar (Note order).

- j. Remove snap ring using snap ring pliers.
- k. Ball screw, spring and rack assembly will now slide out of housing. Note - do not allow ball screw shaft to spiral out of assembly. Put wire or O-ring around end of ball screw shaft.

CAUTION: Do not attempt to disassemble spring assembly. Spring is under high compression and can cause severe injury if released.

- l. Reassemble ball screw, spring and rack assembly in main housing. It is important that the rack be correctly engaged with the drive gear assembly. With ball screw, spring and rack assembly fully inserted into main housing, guide pin hole in top of drive shaft must be on long axis of operator, towards motor end. If drive gear assembly is not correctly positioned, remove ball screw, spring and rack assembly from main housing, reposition drive shaft assembly and reassemble.
- m. Reinstall snap ring. Note - two snap rings are different, install non-beveled snap ring first.
- n. Reinstall thrust collar, washer, bearing and washer.
- o. Reinstall spring and screw support.
- p. Reinstall beveled snap ring with bevel towards you.
- q. Reinstall thrust washer, bearing, washer & collar.
- r. Reinstall screw on key in ball screw shaft, apply bearing lock washer and lock nut.
- s. Tighten lock nut finger tight and bend tab of lock washer to hold it in place.
- t. Install **new** gasket on main housing and reassemble motor and gear housing assembly.
- u. Plug motor lead into operator switch box.

REPAIR OR REPLACE

PROCEDURE

7. Replace end plate/main housing gasket.	<ul style="list-style-type: none"> a. Remove 6 (die cast housing) or 4 (sand cast housing) screws. b. Remove old gasket and examine end cap and main housing surface. If end cap is bent or gouged, replace. If main housing surface is gouged, replace entire operator. c. Install new gasket and reinstall end cap & screws.
8. Replace drive shaft & gear assembly.	<ul style="list-style-type: none"> a. Remove operator switch box cover, switches and complete cam assembly. b. Remove ball screw, spring and rack assembly - see 6 a-k above. c. Using snap ring pliers, remove large snap ring retaining large bearing of drive shaft assembly in main housing. d. With main housing well supported, press drive shaft assembly out of main housing. e. Install replacement drive shaft assembly. Note - a "bullet nose" must be placed over the spline shaft end to protect the seal and assure correct seal lip placement. Seal lip must project inward on shaft surface. f. Reassemble drive elements into main housing, see 6 1-u above. g. Reassemble cam assembly and switches. h. Power operator and adjust cams. i. Reinstall switch box covers.
9. Repair wiring in operator switch box.	<ul style="list-style-type: none"> a. Remove switch box covers; disconnect motor and control box connectors. b. Check wiring to schematic. Retighten or reconnect any loose wires; remove any shorts; test diodes and closing speed resistor with an ohmmeter.

REPAIR OR REPLACE

PROCEDURE

	<p>c. Reinstall switch box covers and reconnect motor and control box.</p>
<p>10. Replace any of switches.</p>	<p>a. Remove switch box covers, disconnect motor and control box connectors.</p> <p>b. Locate suspected switch; remove wires from switch terminals and check switch with meter. If faulty . . .</p> <p>c. Remove two screws holding switch in place.</p> <p>d. Install replacement switch; reinstall screws and reconnect wires to correct terminals.</p> <p>e. Reconnect motor and control box connectors.</p> <p>f. Check ALL cam adjustments. See Tune-in Procedure.</p> <p>g. Reinstall switch box covers.</p>

IMPORTANT

After any repair, operator must be tested for correct and safe operation. After any internal component replacement, operator should be run-in on a bench for one hour at a rate of five (5) cycles per minute. Use a cycle timer. At completion of run-in, performance of operator should be:

Open to open check: 1.25 - 1.6 sec.

Open through open check: 1.0 - 1.5 secs.

Close to latch check: 2.5 - 4.0 secs.

Close through last 10°: no less than 1.5 secs.

ELECTRICAL SCHEMATIC

OPERATOR SWITCH BOX

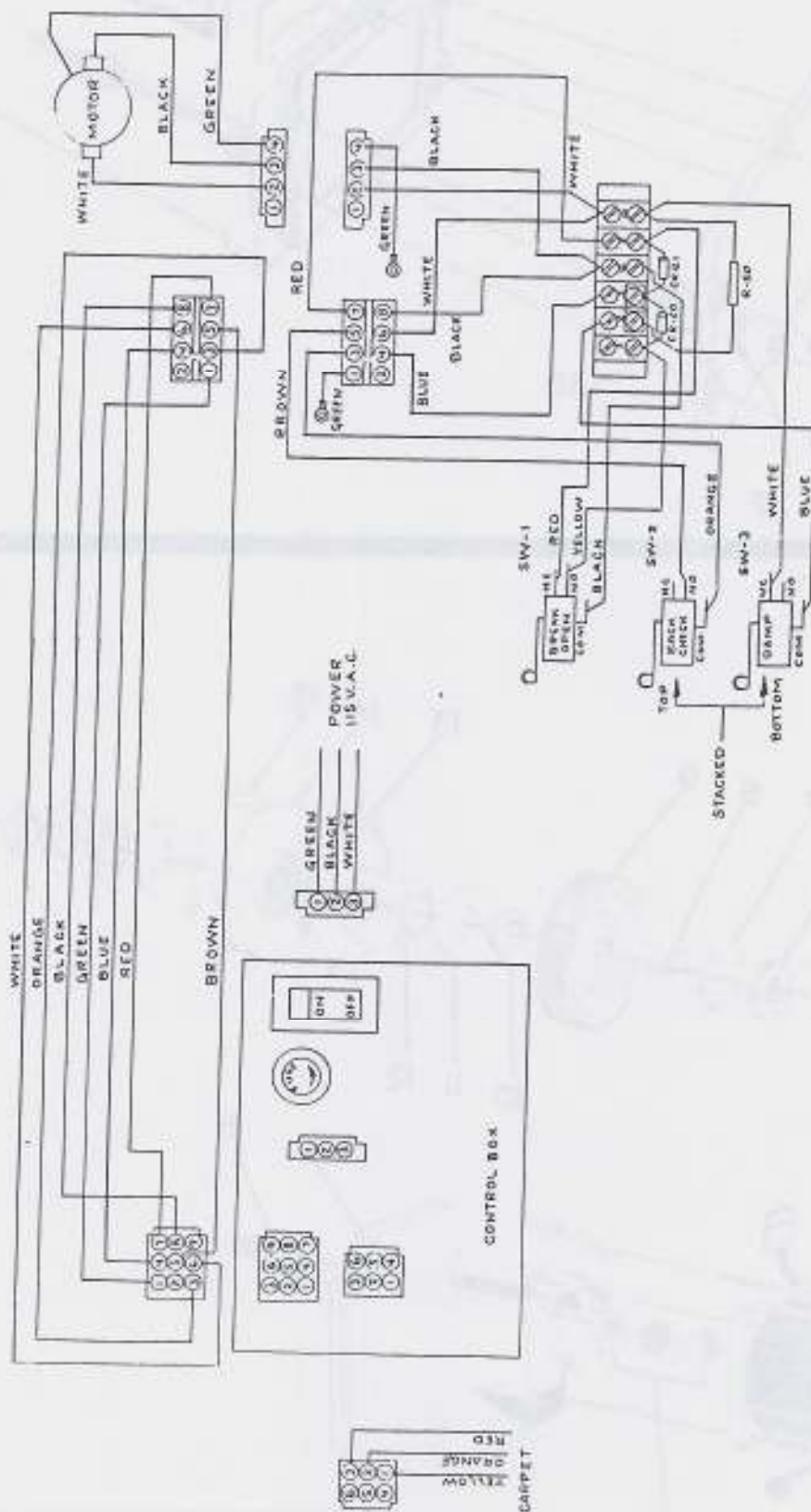

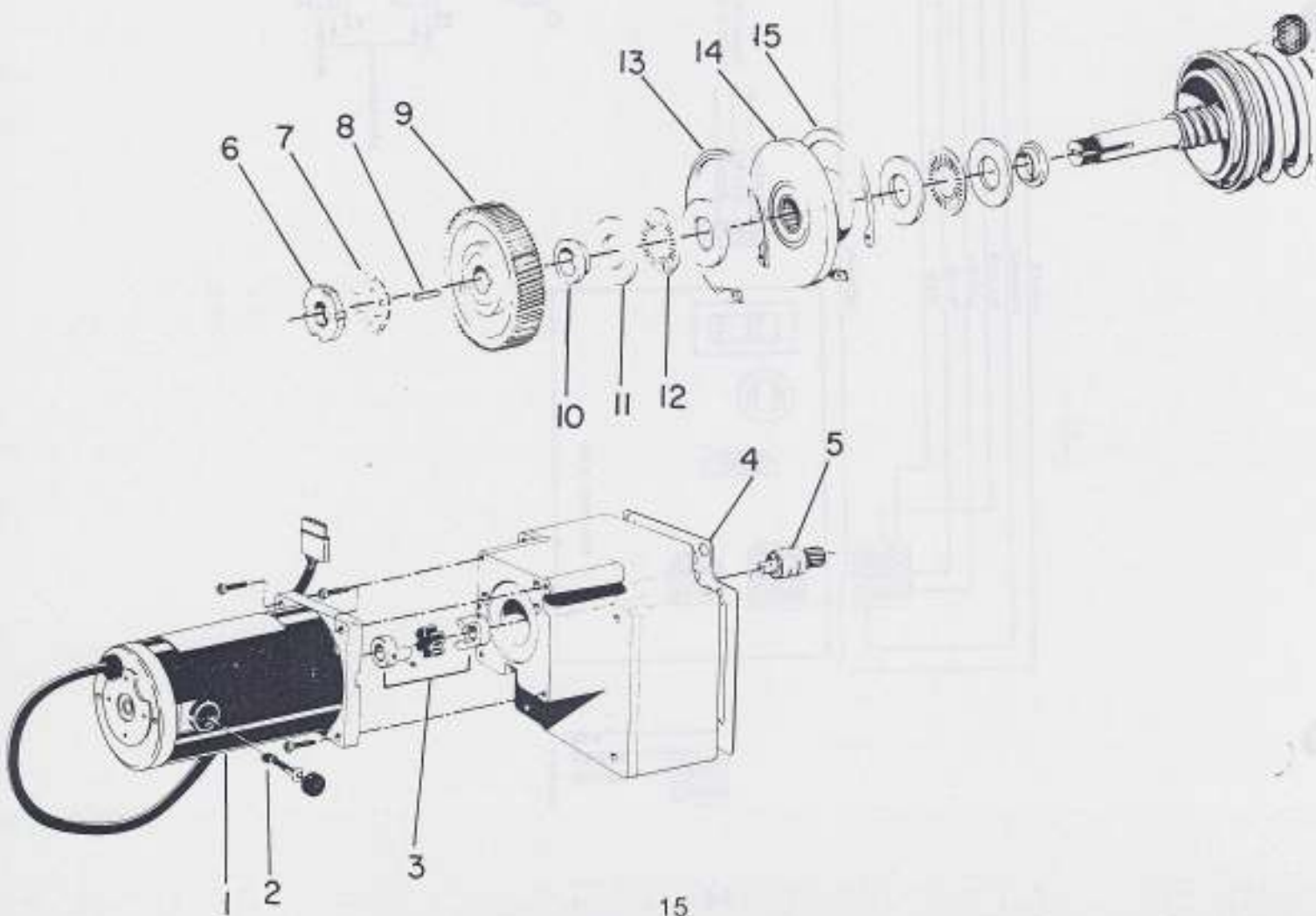
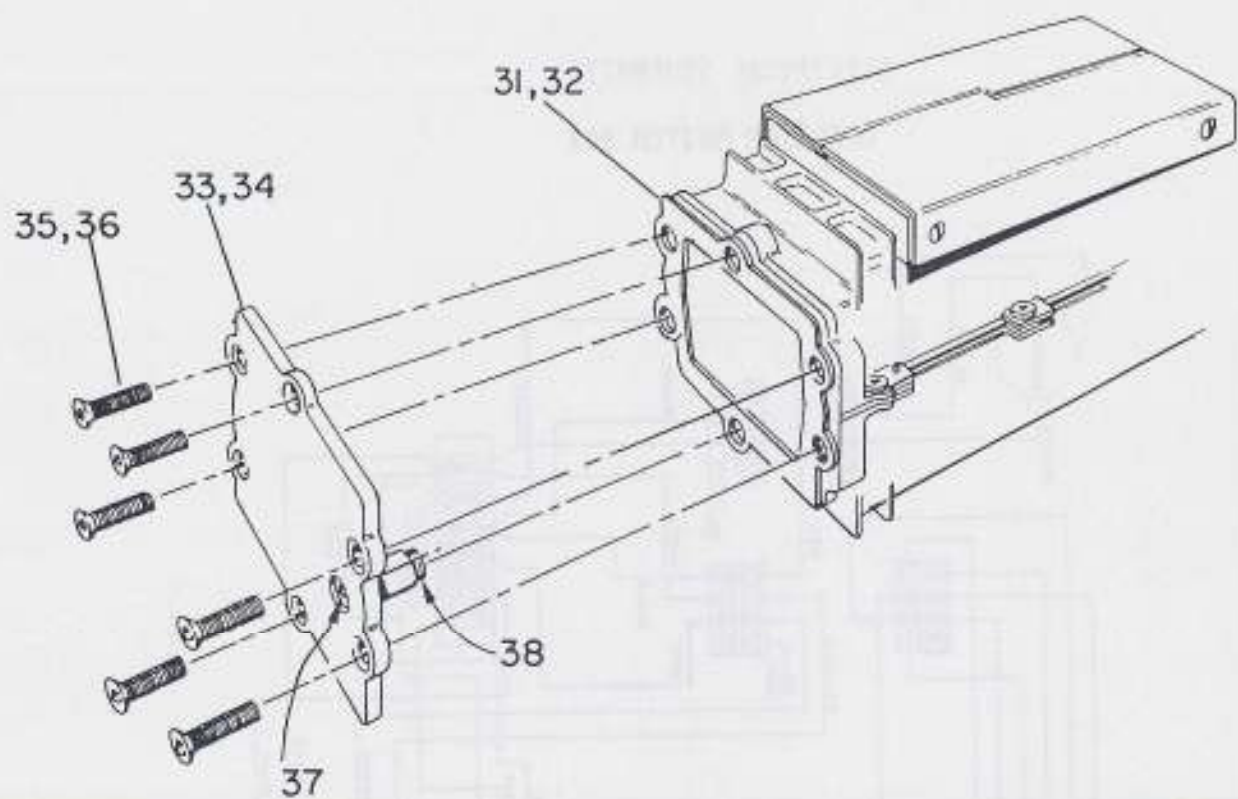

DRIVE SHAFT
SHAFT ASSEMBLY

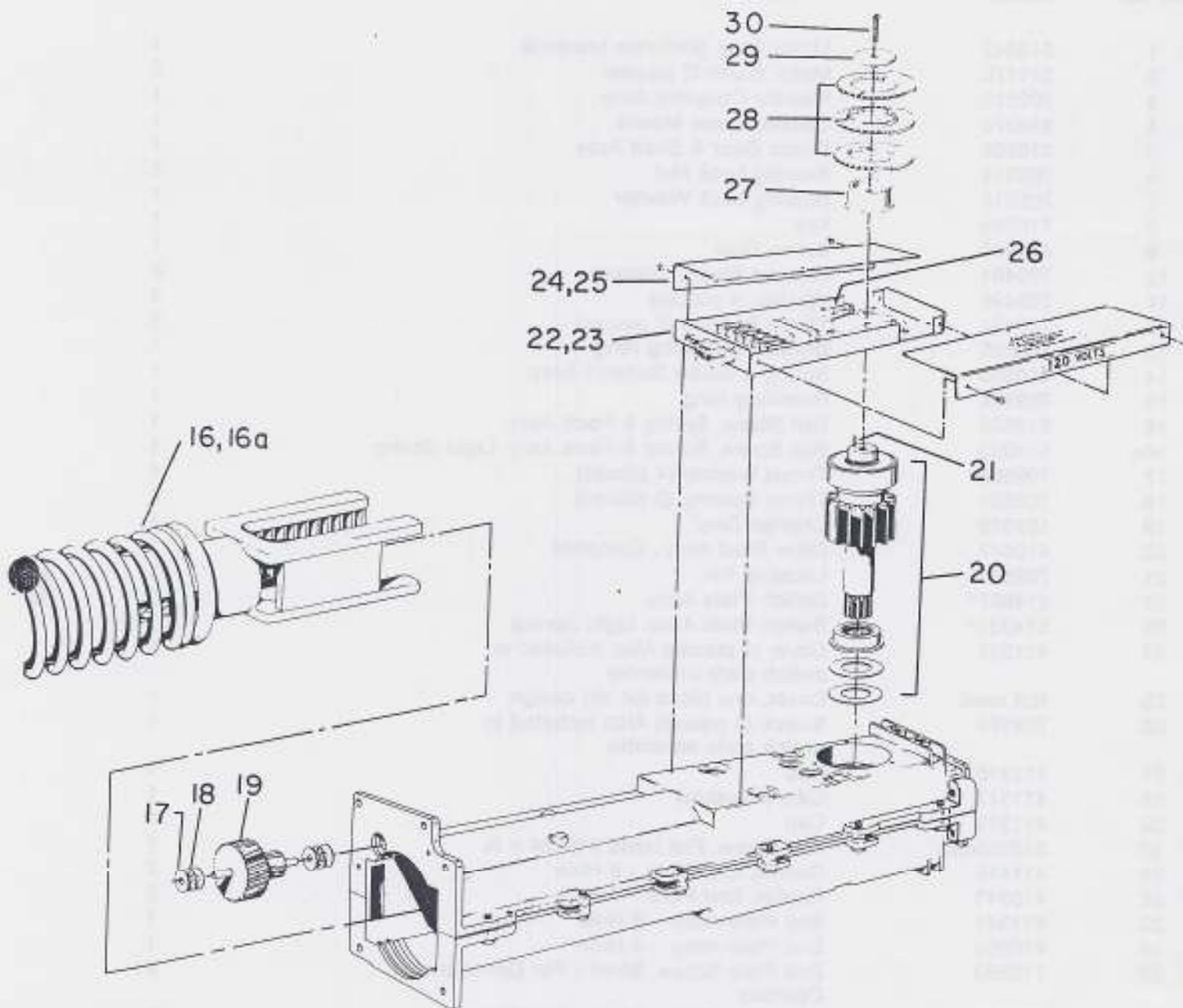

(SEE NEXT PAGE FOR PARTS DETAILS)

MAGIC-SWING REPLACEMENT PARTS

Ref. No.	Part No.	Description	Quantity
1	514542	Motor Assy. (includes brushes)	1
2	311770	Motor Brush (2 places)	2
3	709513	Flexible Coupling Assy.	1
4	514975	Gasket, Motor Mount	1
5	410565	Pinion Gear & Shaft Assy.	1
6	709514	Bearing Lock Nut	1
7	709515	Bearing Lock Washer	1
8	710059	Key	1
9	411340	Screw Gear	1
10	709491	Support Ring (2 places)	2
11	709499	Washer (4 places)	4
12	709497	Thrust Bearing (2 places)	2
13	709505	Beveled Retaining Ring	1
14	410853	Spring & Screw Support Assy.	1
15	709504	Retaining Ring	1
16	514528	Ball Screw, Spring & Rack Assy.	1
16a	514933	Ball Screw, Spring & Rack Assy. Light Spring	1
17	709502	Thrust Washer (4 places)	4
18	709501	Thrust Bearing (2 places)	2
19	107518	Change Gear	1
20	410547	Drive Shaft Assy., Complete	1
21	709518	Locating Pin	1
22	514887*	Switch Plate Assy.	1
23	514934*	Switch Plate Assy. Light Spring	1
24	411328	Cover (2 places) Also included in switch plate assembly	1
25	Not avail.	Cover, one piece for old design	-
26	708184	Switch (3 places) Also included in switch plate assembly	1
27	411316	Hub	1
28	411317	Cam (3 places)	1
29	411318	Cap	1
30	312030499	Top Screw, Flat Head #10-24 x 7/8	1
31	411416	Gasket, End Plate - 6 Hole	2
32	410843	Gasket, End Plate - 4 Hole	2
33	411341	End Plate Assy. - 6 Hole	1
34	410569	End Plate Assy. - 4 Hole	1
35	710593	End Plate Screw, Short - For Concealed Operator	6
36	710594	End Plate Screw, Long - For Visible in Operator	6
37	347735000	Jamb Screw, Flat Pt. Set 1/2-20 x 3/8	1
38	347743000	Stop Screw, Set 1/2-20 x 1 1/2	1
39	710061	Grease	1 lb.

*Switch Plate Assembly includes covers, terminal strip, switches, resistors, diodes, and wiring.

Stanley Magic-Door*
Division of The Stanley Works
Farmington, CT 06032
Tel. (203) 677-2861

(Printed In U.S.A.)

MAGIC-SWING™

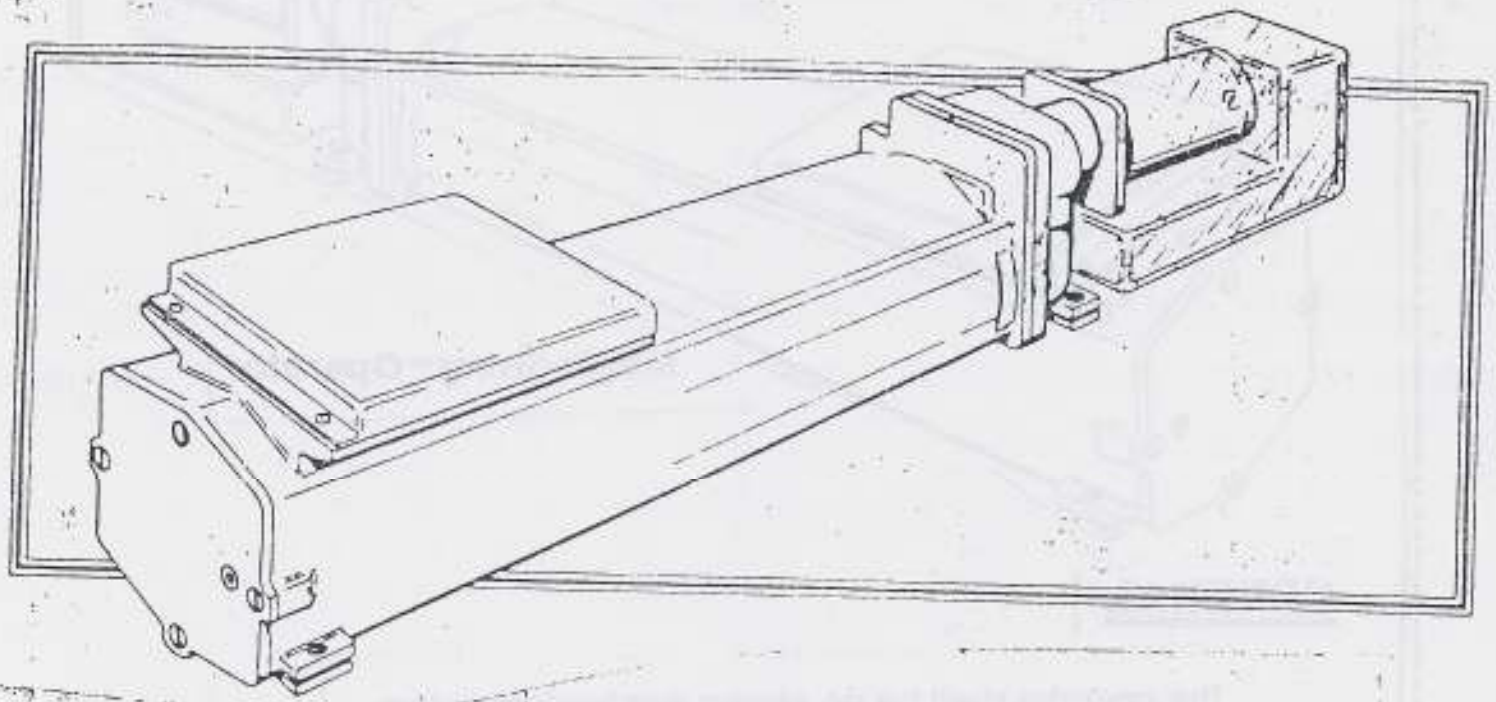

FUNCTIONAL OPERATION
TROUBLE SHOOTING
and
MAINTENANCE MANUAL

STANLEY MAGIC-DOOR

DIVISION OF THE STANLEY WORKS

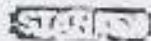

FARMINGTON CONN. 06033

OPERATION

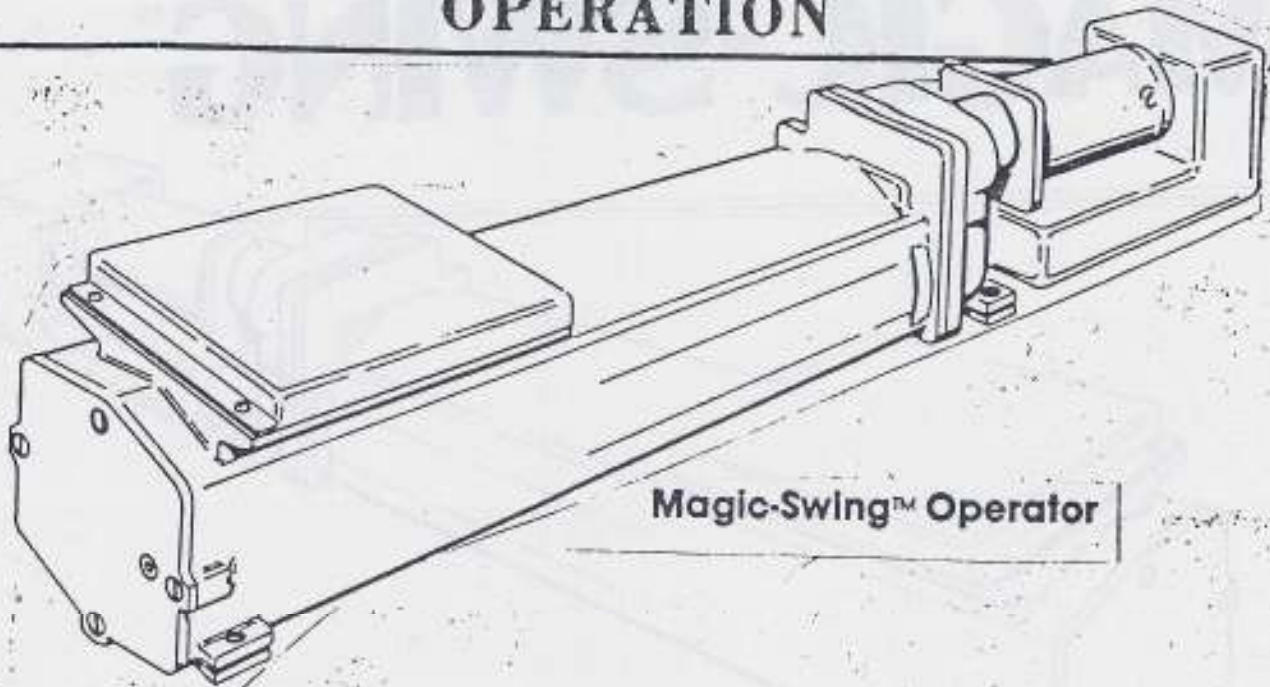

Magic-Swing™ Operator

GENERAL

The operator shall be an electro-mechanical system, sealed against dust, dirt and corrosion in a cast aluminum case, and fully lubricated to minimize wear and friction of moving parts between temperature extremes of -20°F (-29°C), and 140°F (60°C). The operator shall be mounted in the header with vibration isolators for quiet operation. The entire operator shall be removable from the header as a unit.

FUNCTIONAL

THE MAJOR SUB-ASSEMBLIES ARE:

motor

The Magic-Swing operator uses a permanent magnet DC motor (instead of a wound type) because it reduces the amount of current to operate. This also allows the motor to be used as a dynamic brake to control the speed of closing. The motor is also smaller in size, as opposed to a wound type.

The operator shall open the door with a 1/8 hp DC motor through reduction gears

OPERATION

reduction gears

The operator shall open the door with a 1/8 hp DC motor through reduction gears

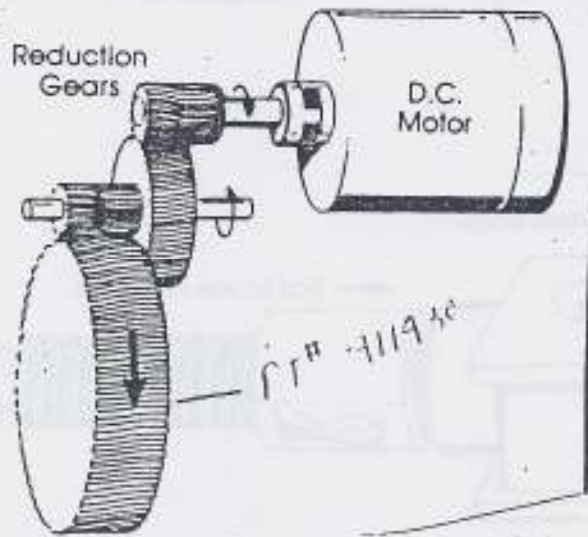

ball screw actuator

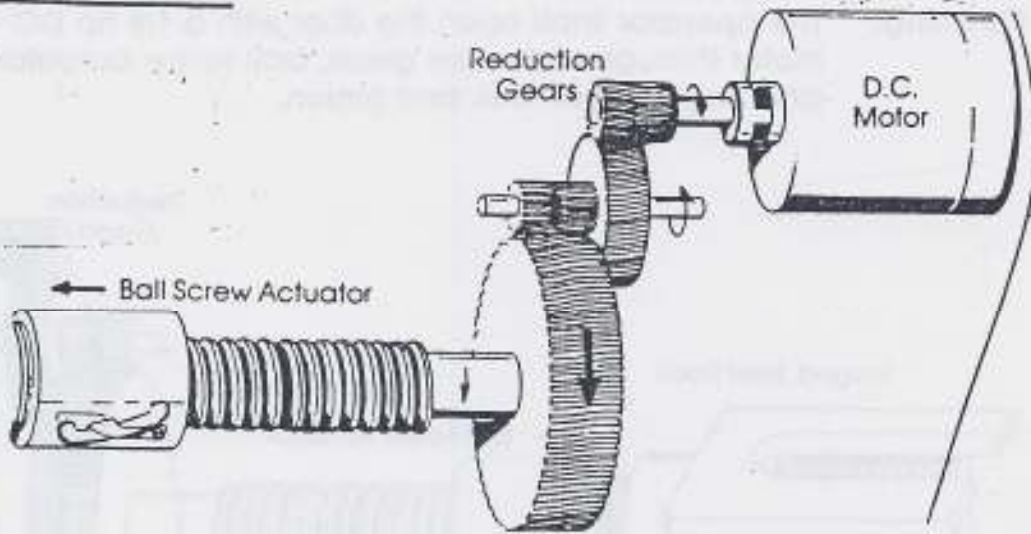

OPERATION

forged steel rack

The operator shall open the door with a 1/8 hp DC motor through reduction gears, ball screw actuator, and forged steel rack

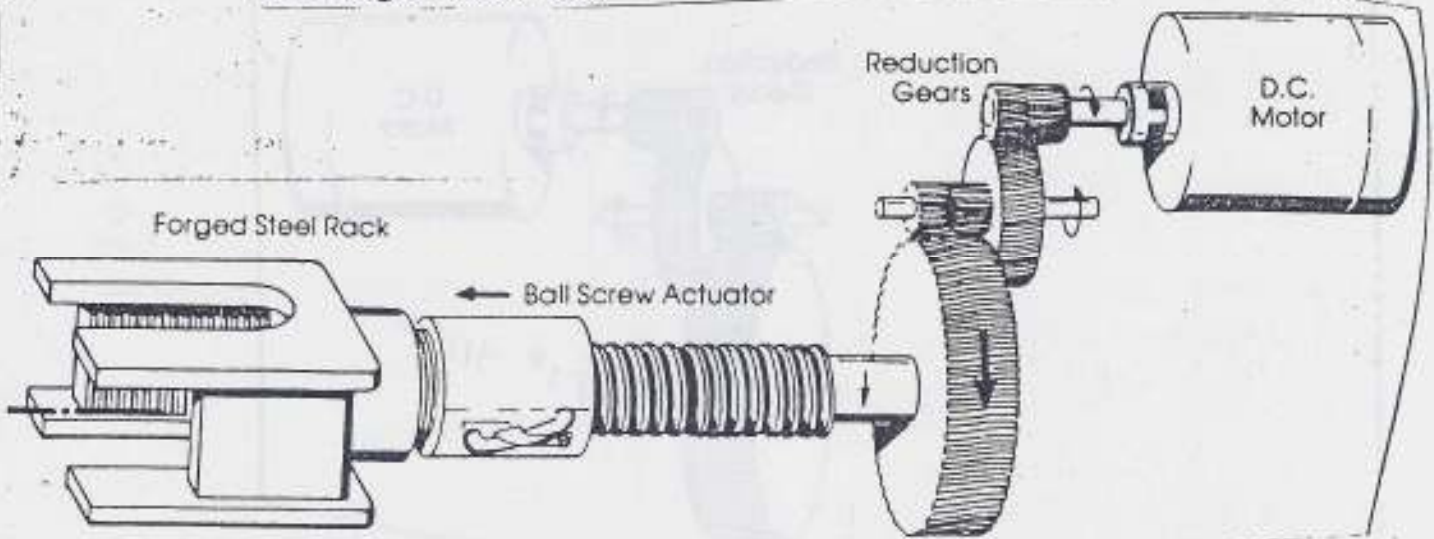

Power Opening: The operator shall open the door with a 1/8 hp DC motor through reduction gears, ball screw actuator, and forged steel rack and pinion.

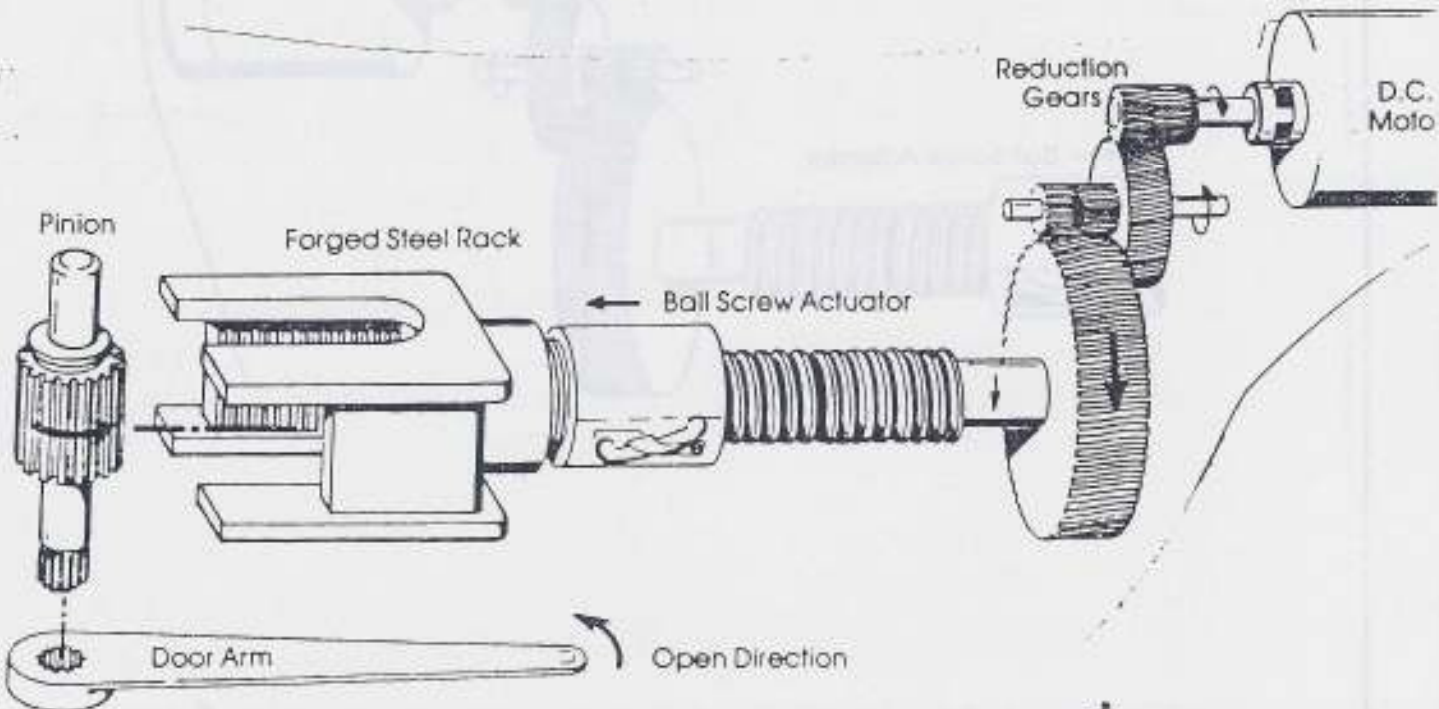

OPERATION

Spring Closing:

The operator shall close the door by spring energy. Closing speed shall be controlled by employing the motor as a dynamic brake, and closing to latch check (approximately 10°) shall be in 3 seconds. Closing through last 10° shall be in 1.5 seconds minimum. The closing spring shall be a helical compression spring, preloaded for positive closing action at a low material stress level for long spring life.

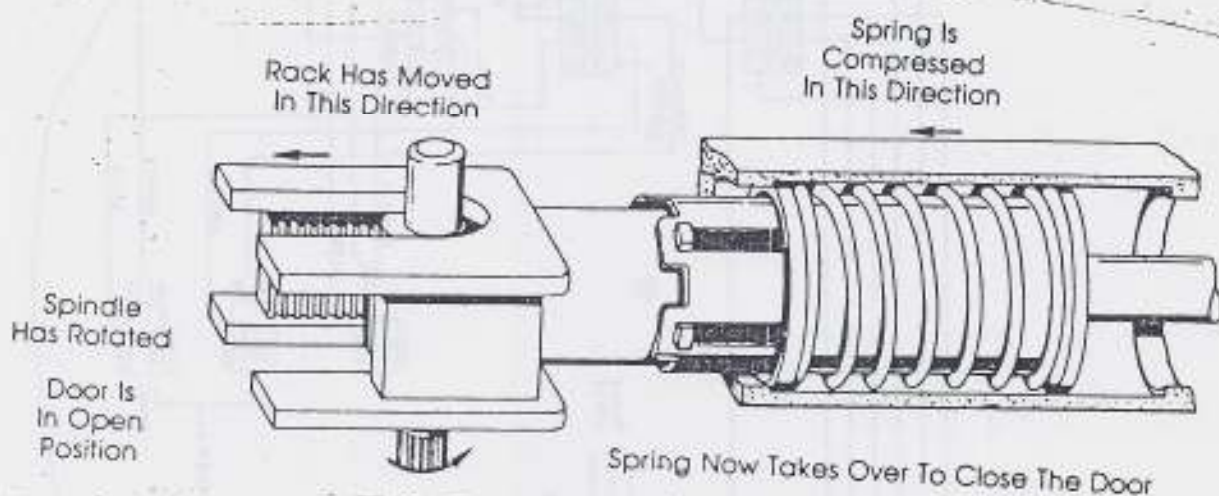

Emergency Release:

The operator shall have built-in emergency release with controlled spring return to the closed position without manual resetting. While the door is in the emergency release mode, a disconnect switch shall prevent powered operation.

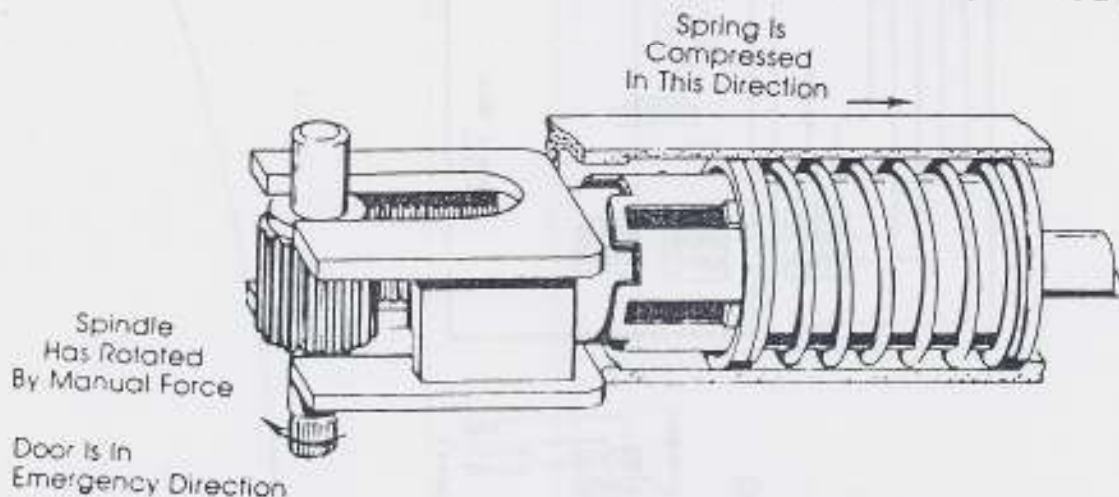

TUNE-IN AND ADJUSTMENT

MECHANICAL ADJUSTMENTS

DOOR ZERO POSITION

IN-HEADER APPLICATIONS

1. 0° DOOR POSITION CAN BE ADJUSTED BY AT THE DOOR ARM.

- REMOVE DOOR ARM LOCK SCREW
- REPOSITION DOOR ARM AND DOOR ARM LOCK AS SHOWN
- INSTALL DOOR ARM LOCK SCREW

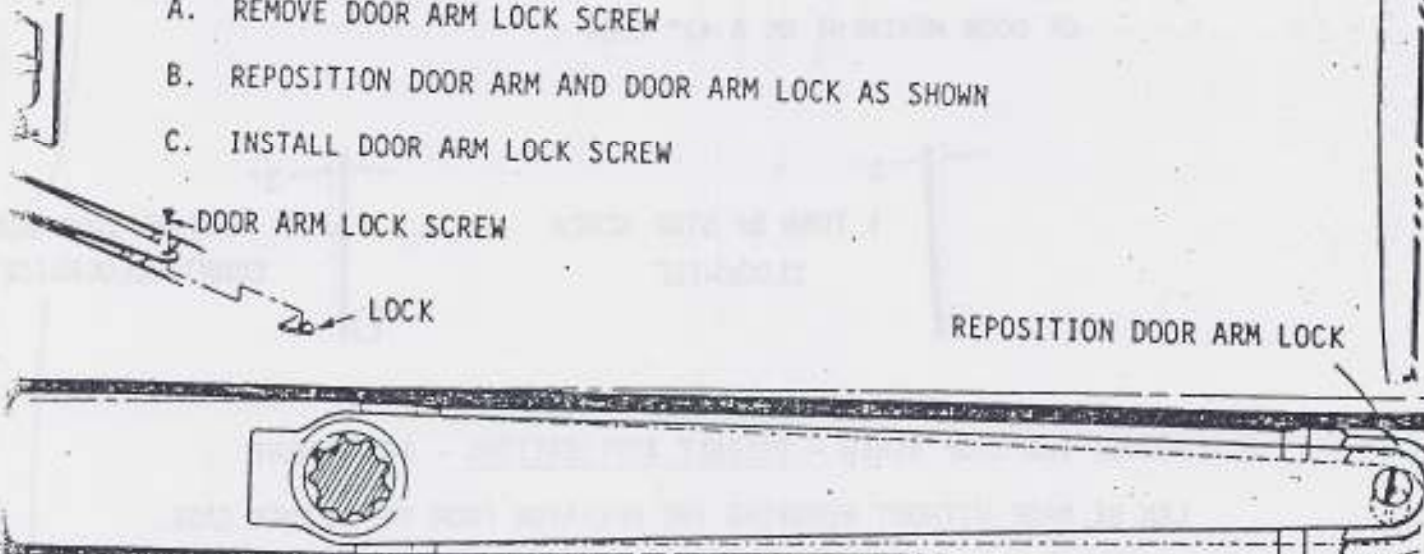

OUT APPLICATIONS

0° DOOR POSITION CAN BE MADE BY ADJUSTING THE DOOR ARM LINKAGE.

- REMOVE THE VISIBLE DOOR ARM SCREW AND FORCE THE DOOR ARM OFF THE SPINDLE SHAFT WITH A $1/2 - 13$ BOLT AS A PULLING TOOL.
- REPOSITION THE DOOR WITH LINKAGE HUB OVER THE SPINDLE AND SECURE WITH THE DOOR ARM SCREW.

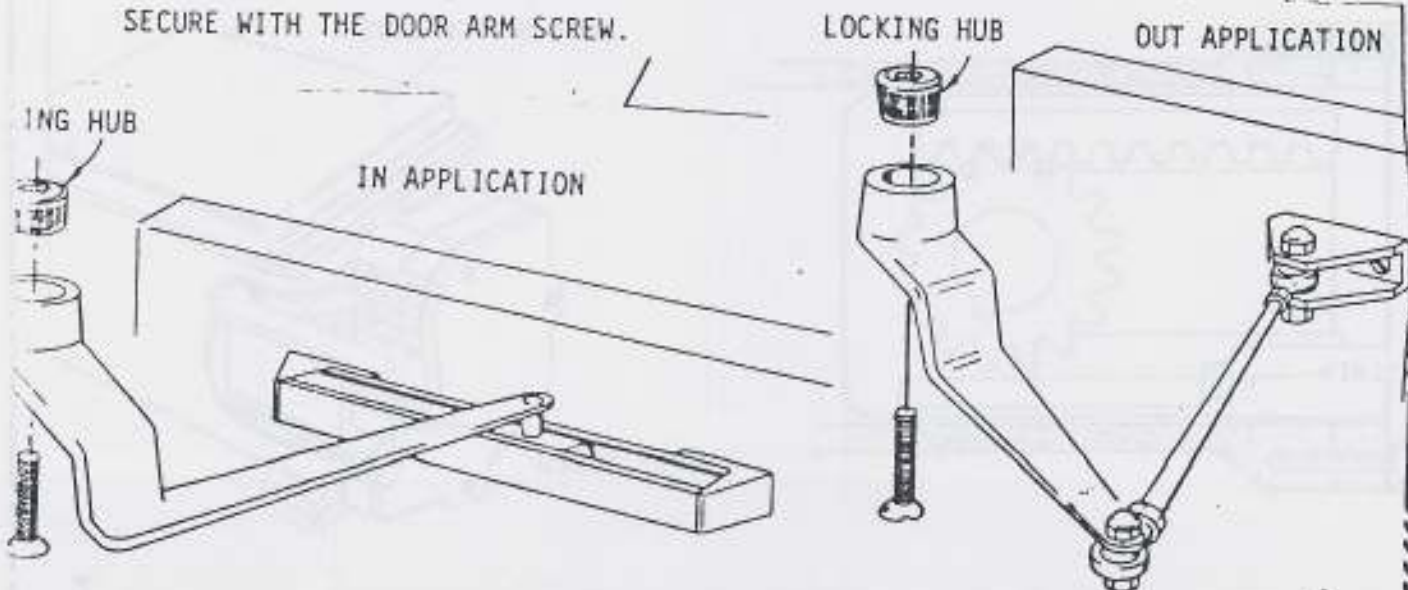

TUNE-IN AND ADJUSTMENT

90 DEGREE

1. OPEN THE DOOR MANUALLY UNTIL YOU FEEL THE OPERATOR REACH ITS INTERNAL STOP.
2. DETERMINE HOW MUCH MORE OR LESS TRAVEL IS REQUIRED FOR PROPER 90° OPERATION.

NOTE: 1 TURN OF THE STOP SCREW IS APPROXIMATELY 3"
OF DOOR MOVEMENT ON A 42" DOOR

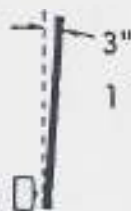

1 TURN OF STOP SCREW
CLOCKWISE

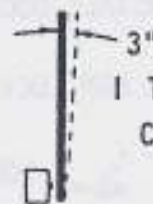

1 TURN OF STOP SCREW
COUNTERCLOCKWISE

3. ADJUST THE STOP SCREW - VISIBLE APPLICATIONS - ADJUSTMENT CAN BE MADE WITHOUT REMOVING THE OPERATOR FROM THE HEADER CASE. IN-HEADER APPLICATIONS - ADJUSTMENT REQUIRES REMOVAL OF THE OPERATOR FROM THE HEADER.

NOTE: ONCE THE STOP SCREW HAS BEEN ADJUSTED, YOU MAY HAVE TO ADJUST THE OPENING CHECK SWITCH CAM TO OBTAIN THE RECOMMENDED 15° OF CHECKING ACTION (SEE CHART BACK OF PAGE)

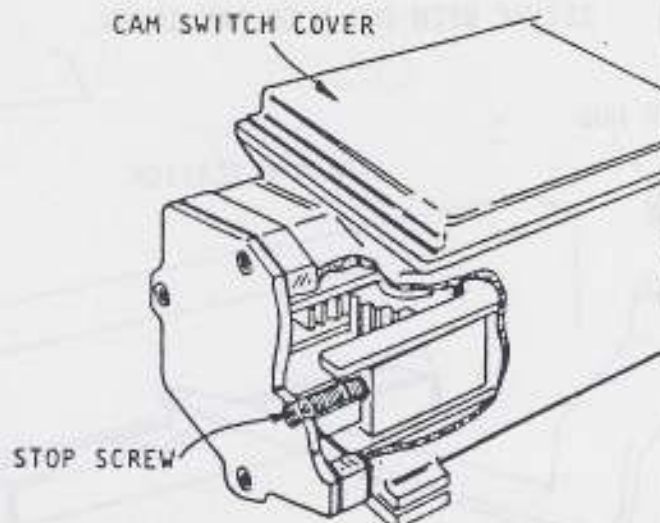
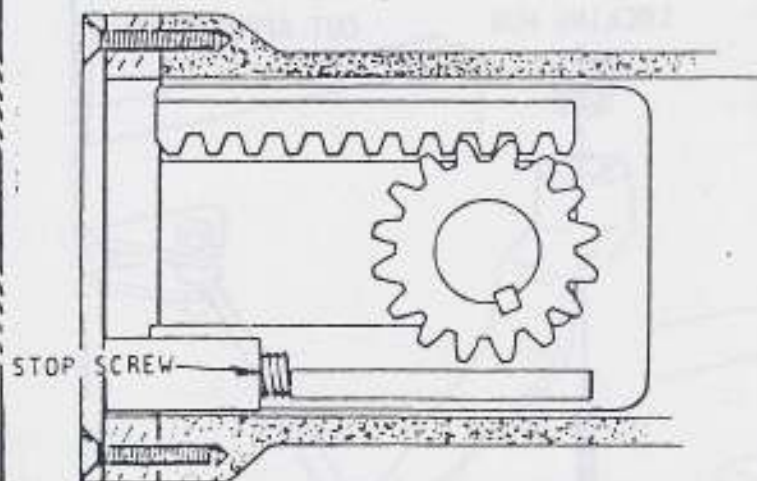

TUNE-IN AND ADJUSTMENT

SWITCH CAM ADJUSTMENT

1. TO MAKE SWITCH CAM ADJUSTMENTS ON EITHER VISIBLE OR IN-HEADER OPERATORS, THE OPERATOR MUST BE REMOVED AND PLACED ON A BENCH.

NOTE: TO REMOVE THE OPERATOR IN A VISIBLE APPLICATION DO THE FOLLOWING TO DISCONNECT THE VISIBLE LINKAGE.

- A. REMOVE THE VISIBLE DOOR ARM SCREW AND FORCE THE DOOR ARM OFF THE SPINDLE SHAFT WITH A 1/2 - 13 BOLT AS A PULLING TOOL.
2. HOOK UP TEMPORARY POWER TO THE OPERATOR.
 3. ATTACH A SPINDLE POSITION LOCATOR TO THE OPERATOR (WE RECOMMEND AN IN-HEADER DOOR ARM.)
 4. THE SPINDLE POSITION LOCATOR MUST BE PLACED IN THE 0° POSITION WITH THE OPERATOR OFF. (FULL CLOSED)
 5. SHORT THE YELLOW AND ORANGE SIGNAL WIRES. CAUTION: THE OPERATOR WILL POWER THE SPINDLE POSITION LOCATOR TO THE FULL OPEN POSITION - STAND CLEAR.
 6. REMOVE THE CAM SWITCH COVER.

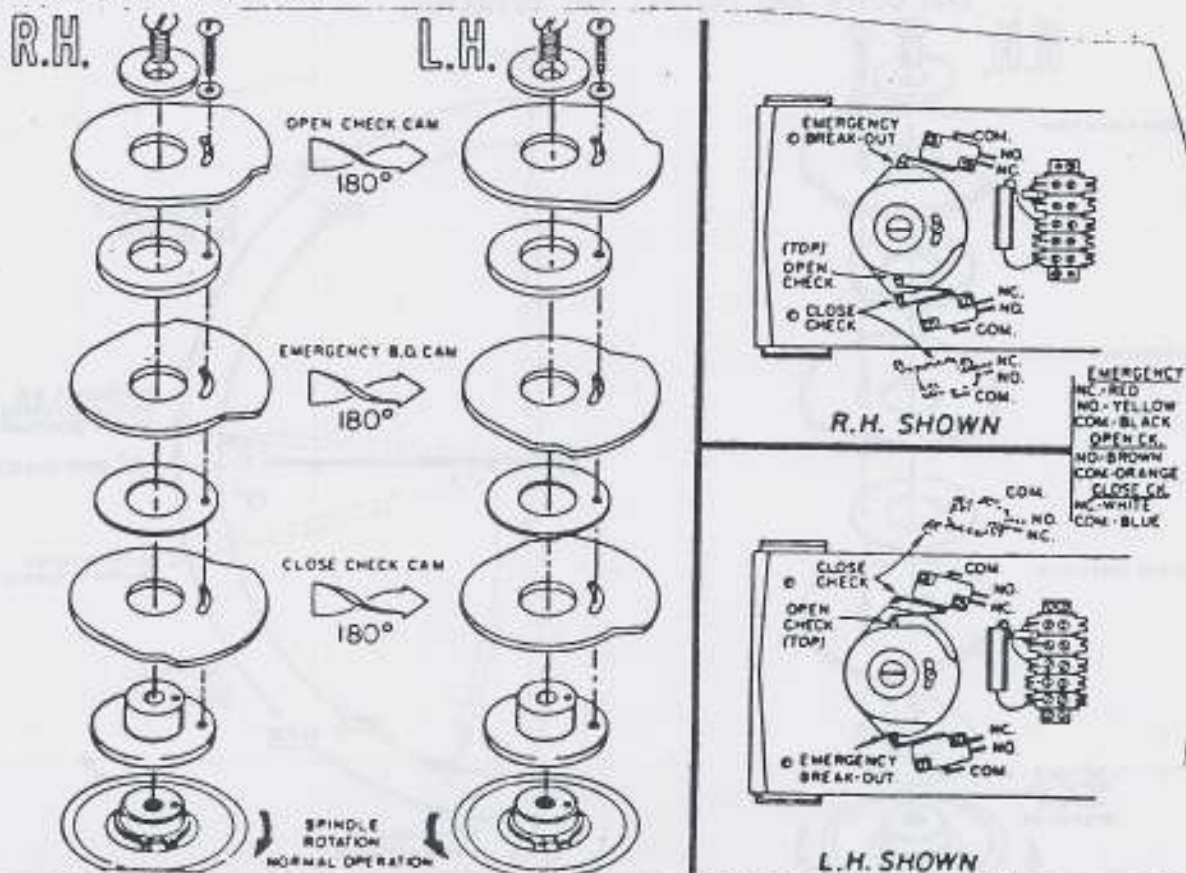

TUNE-IN AND ADJUSTMENT

7. TO REDUCE THE OPERATOR OPEN CHECK DO THE FOLLOWING:
- TURN OFF POWER
 - LOOSEN THE CENTER CAM SCREW AND THE CAM ADJUSTMENT SCREW.
 - ROTATE THE TOP CAM ONLY - COUNTER CLOCKWISE R.H. OPERATOR
CLOCKWISE L.H. OPERATOR
 - TIGHTEN THE CENTER CAM SCREW AND THE CAM ADJUSTMENT SCREW.
TURN POWER ON AND OPERATE.
8. TO INCREASE THE OPERATOR OPEN CHECK DO THE FOLLOWING:
- TURN OFF POWER
 - LOOSEN THE CENTER CAM SCREW AND THE CAM ADJUSTMENT SCREW
 - ROTATE THE TOP CAM ONLY - CLOCKWISE R.H. OPERATOR
COUNTER CLOCKWISE L.H. OPERATOR
 - TIGHTEN THE CENTER CAM SCREW AND THE CAM ADJUSTMENT SCREW.
TURN POWER ON AND OPERATE.
9. IF THE ADJUSTMENTS MADE ARE AS REQUIRED REPLACE THE SWITCH CAM CAM COVER AND INSTALL THE OPERATOR.

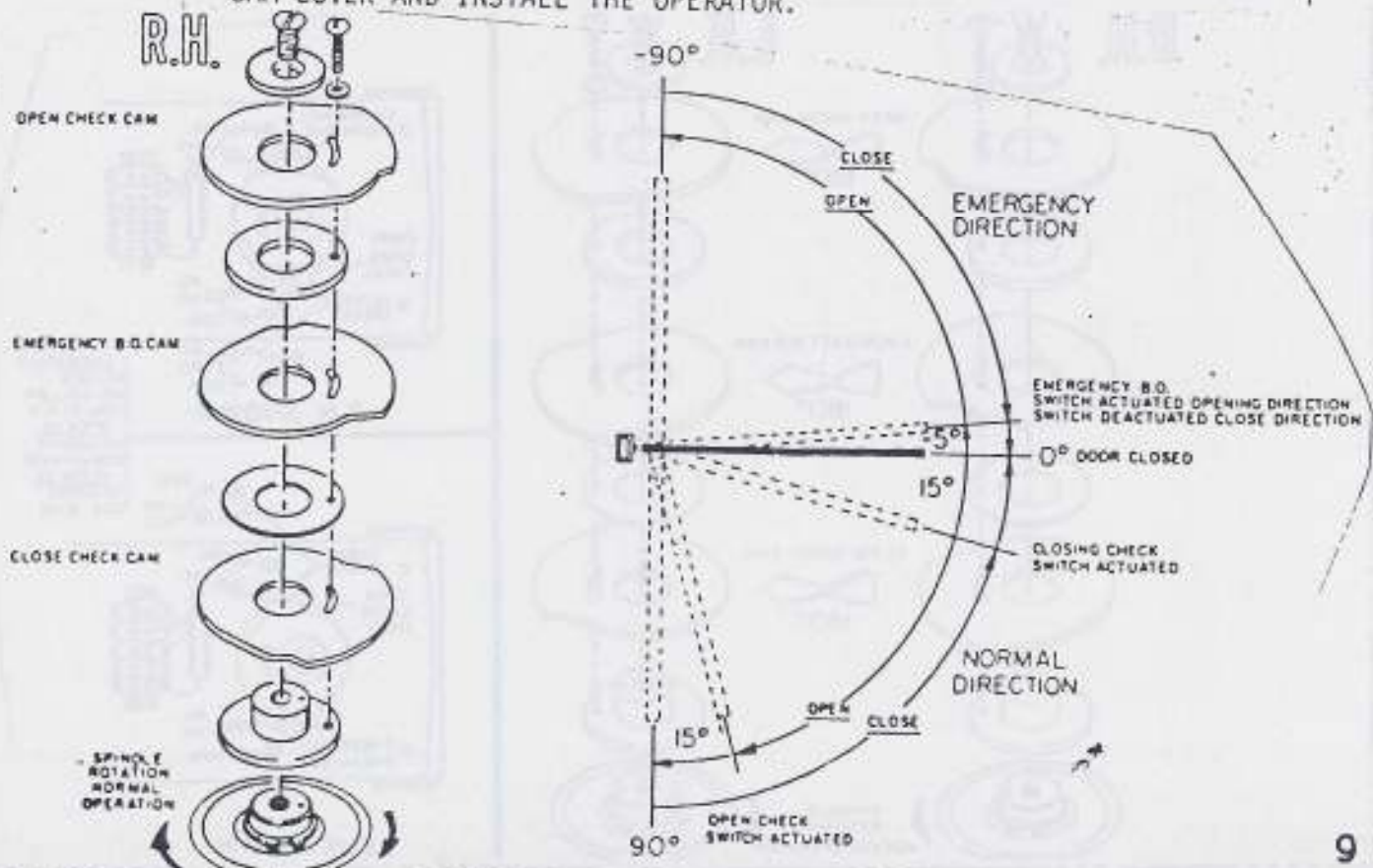

MAGIC SWING FIELD TROUBLE SHOOTING CHART

TROUBLE	TEST	CAUSE	REMEDY
Door will not open when opening carpet is actuated. (Motor does not run) continued	Disconnect power leads 3-pin connector at control box. Check for supply voltage of 117 v. between pins 3 and 4 (black & white). If no voltage	Circuit breaker at main panel tripped.	Reset breaker.
	Verify that all four lead connectors are firmly plugged together.	An intermittent contact can open due to motor vibration.	Plug connectors together firmly.
Door will not open when opening carpet is actuated.	(1) Install new control box. If operator now O.K.	Original control box defective.	Replace control box. Refer to Control Box Trouble Shooting.
Door will not close with no object on carpets.	(1) On-Off, Hold-Open switch on Hold-Open.		Put switch in "On" position.
	(2) Disconnect opening carpet. If door closes	Opening carpet or leads shorted.	Replace opening carpet.
	(3) Disconnect safety carpet. If door closes	Safety carpet or leads shorted.	Replace safety carpet.
Noisy Operation.	(1) Vibration during powered opening cycle.	Door arm mounting screws loose.	Tighten door arm screws.
		Loose glass, glass stops, header or jambs.	Tighten or refasten loose parts of door or frame.
		Operator vibrating against header.	Tighten mounting screws.
		Control box vibrating against header.	Check control box mounting fasteners.
		Header cover loose.	Replace any missing cover screws

MAGIC-SWING FIELD TROUBLE SHOOTING CHART

TROUBLE	TEST	CAUSE	REMEDY
Door will not open when opening carpet is actuated. (Motor does not run)	(1) Check On/Off/Hold-open switch. It should be in the "On" position for powered operation. If not		Put switch in "On" position.
	(2) Put On/Off/Hold-Open switch on "Hold-Open". If door now opens	Faulty opening carpet or leads.	Test for faulty "open" carpet. Replace if necessary.
	(3) Check On/Off switch on control box. It should be in the "On" position for powered operation. If not		Put switch in "On" position.
	(4) Disconnect safety carpet at wire nut splice. If door now opens when opening carpet is actuated or switch if on "Hold-Open"	Safety carpet or leads shorted.	Replace safety carpet.
	(7) Check fuse in control box for continuity. Be sure to turn off power before removing fuse. If fuse is open		Replace fuse and exercise operator thoroughly.
	(8) If new fuse blows	Suspect circuit board component.	Replace control box. Refer to control box trouble shooting.

MAGIC-SWING FIELD TROUBLE SHOOTING CHART

TROUBLE	TEST	CAUSE	REMEDY
1. Door not centered on jamb in closed position.	(1) Door dragging on threshold or on jamb.	Worn pivot, door arm loose in door, sagging door, damaged weatherstripping.	Adjust or replace worn pivots, sagging door or tighten door arm mounting screws.
	(2) Excessive free play between door arm and spindle (move door, spindle does not move)	Loose or deformed door arm.	Tighten loose door arm, replace deformed door arm.

MAGIC-SWING FIELD TROUBLE SHOOTING CHART

This trouble shooting chart should be used after it has been determined that the control box has failed. Symptom in all cases is "Control Box Defective". (Ohm meter should be "zeroed" for each scale used.)

TEST	PROCEDURE AND REMEDY
"On-Off" Power Switch	Disconnect 6 pin connector. Place OHM meter (R x 1 ohms scale) across terminals 1 and 2 of "On-Off" switch. Place On-Off switch in "On" position. Meter should read 0 ohms. If not, switch is defective and box should be replaced. If zero ohms, place switch in "Off" position. Meter should read infinite ohms. If not, switch is defective and control box should be replaced.
Fuse	Place On-Off switch in "Off" position. Place ohm meter (R x 1 ohms scale) across fuse holder. Meter should read 10 to 60 ohms. If not, replace fuse.

MAGIC-SWING FIELD TROUBLE SHOOTING CHART

GLOSSARY OF TERMS

CCW	Counter Clockwise
CW	Clockwise
"IN" DOOR	The Door swings under the operator in a visible application, and under the swing up header in an in header application.
LEFT HAND OPERATOR	The operator swings the door in a counter clockwise direction.
NC	Normally Closed
NO	Normally Open
OPERATING CONTROL	Any signal that is used to actuate an operator such as a carpet photo electric, push plate, etc.
"OUT" DOOR	The door swings away from the operator in a visible application, and away from the swing up header cover in an in header application.
RIGHT HAND OPERATOR	The operator swings the door in a clockwise direction.

GLOSSARY OF TERMS

1. Chair - The seat and backrest of the shooting chair.

2. Seat - The part of the chair where the shooter sits.

3. Backrest - The part of the chair that supports the back of the shooter.

4. Adjustable - Capable of being moved or changed in position.

5. Height - The vertical distance from the floor to the top of the chair.

6. Depth - The horizontal distance from the front to the back of the chair.

7. Weight - The mass of the chair, measured in pounds or kilograms.

8. Stability - The ability of the chair to remain steady and balanced.

9. Portability - The ease with which the chair can be moved or transported.