

Stanley Access Technologies
Quick-Reference Guide



**Dura-Storm Impact Series
Installation Instructions
Quick-Reference Guide
203974
Rev. A, 8/21/01**

Prohibition on Copying

Any unauthorized reproduction, disclosure or distribution of copies by any person of any portion of this work may be a violation of copyright law of the United States of America and other countries, could result in the awarding of statutory damages of up to \$250,000 (17 USC 504) for infringement, and may result in further civil and criminal penalties. All rights reserved.

Quick-Reference Guide

TABLE OF CONTENTS

1. PURPOSE.....	2
1.1 Discussion.....	2
1.2 Applicability	2
1.3 Features and Functions	2
2. PREREQUISITES	3
2.1 Special Items Required for Installation	3
3. INSTALLATION INSTRUCTIONS	3
3.1 Checking the Rough Opening.....	3
3.2 Installing the Sensors on the Header	3
3.3 Attaching the End Caps to the Jambs	4
3.4 Installing the Header and Jamb Assembly.....	4
3.5 Installing the Threshold/Track.....	6
3.6 Installing the Keystrips and Angle Brackets (2000-Series Doors Only)	8
3.7 Installing the O Panels (2000-Series Doors Only).....	9
3.8 Applying Foam Sealant to the Frame	11
3.9 Installing the SO Panels (3000-Series Doors Only)	12
3.10 Installing the Wind-Resistant Damper Assembly (3000-Series Doors Only)	14
3.11 Installing the SX Panels.....	15
3.12 Adjusting the SX Panels	18
3.13 Verifying that the SX Panels are Centered	18
3.14 Adjusting Belt Tension.....	19
3.15 Adjusting the Full-Open Bumper Stops	20
3.16 Installing the SX Panel Damper Assembly (2000-Series Doors Only)	21
3.17 Adjusting the SX Panel Emergency Egress Breakout Detents	22
3.18 Adjusting the SO Panel Ball Detents (3000-Series Doors Only)	23
3.19 Installing Glass in the Door Panel	24
3.20 Adjusting the SX Panel Sag Following Installation of Glass	26
3.21 Setting the Bottom Sweep	27
3.22 Installing the Stile Lock (2000-Series Doors Only)	28
3.23 Installing the Safety Decals	29

1. PURPOSE

1.1 **Discussion**

This manual provides installation instructions for the Stanley Dura-Storm Impact Series Door. The Dura-Storm Impact Series Door is available in 2000- and 3000-series single-slide and four-panel bi-part sliding door packages. The Impact Series Door has been engineered to withstand a uniform design pressure as required by the Dade County Building Code. The Impact Series Door is offered only with a full breakout panel configuration. Some models, referred to as "steel loaded" may contain square steel tubing inserted into the panel by the factory. Steel loaded packages allow for larger package sizes.

1.2 **Applicability**

This manual is applicable to the Stanley Dura-Storm Impact Series Door. It covers 2000- and 3000-series single-slide and four-panel bi-part sliding door systems. Installation of both "non-steel loaded" and "steel loaded" packages is covered. Transom systems are not available from the factory, but may be supplied by others. Instructions for installing optional accessories such as key switches, door alarm contacts, and push plates are provided in separate installation manuals. This manual does not cover components installed or manufactured by other companies.

1.3 **Features and Functions**

1.3.1 The Dura-Storm Impact Series door systems include the following features and functions:

- Adjustable top pivot
- Caulked glass
- Impact gutters and glass stops
- Foam inside stiles and jambs
- Extra bottom sweep
- Continuous threshold
- Reinforced security hooks
- Flush bolts with lock indicators
- Welded panels
- Top and bottom ball detents
- Eight-laminate hook lock and armored strike (bi-part only)
- Wind-resistant damper
- Bottom rail kick plates (optional)
- Energy absorbing crash bars (optional)
- Heavy duty control and extra motor gearbox (optional)
- Two SU-100 motion sensors
- Two Optex sensors (optional)
- Doorway holding beams (one standard, two optional)
- One Stanguard threshold sensor

203974
Rev. A, 8/21/01
2 of 29

2. PREREQUISITES

2.1 **Special Items Required for Installation**

- 2.1.1 Glass: $\frac{9}{16}$ " , impact-rated (two pieces $\frac{1}{4}$ " clear annealed glass with 0.070 interlayer polycarbonate). No substitute product permitted. Supplied by Security Impact Glass, 6555 Garden Road, Suite 1, Riviera Beach, FL 33404 (561) 844-3100 Fax: (561) 848-9271
- 2.1.2 Dow Corning #995 glazing compound, 18 to 20 tubes per door package
- 2.1.3 "Great Stuff" Minimal Expanding Polyurethane Foam Sealant, two cans per door package
- 2.1.4 GE 100% Silicon Rubber Sealant, 6-12 tubes per package
- 2.1.5 Latex gloves and eye protection for use during foam sealant application
- 2.1.6 Doorway holding beam manufacturer's installation instructions
- 2.1.7 Optex sensor manufacturer's installation instructions
- 2.1.8 Stanley Access Technologies document No. 203743, "Stanley Automatic Sliding Door Safety Decal Installation Guide"
- 2.1.9 Stanley Access Technologies document No. 203957, "SU-100 Motion Sensor Installation and Operation"
- 2.1.10 Anchors for mounting
 - In concrete: $\frac{1}{4}$ " dia. concrete screw embedded $1\frac{1}{2}$ " min.
 - In steel: #14 SMS (Note 18 GA steel min.)
 - In wood: #14 wood screw embedded $1\frac{1}{2}$ " min.

3. INSTALLATION INSTRUCTIONS

3.1 **Checking the Rough Opening**

- 3.1.1 CHECK the floor across the entire opening.
- 3.1.2 IF applicable, CHECK threshold recesses.

NOTE

Opening width should be package width plus $\frac{1}{2}$ " ($\frac{1}{4}$ " each side for shim and caulk clearance). This clearance can be as small as $\frac{1}{8}$ " for a tight appearance with the aluminum storefront construction.

- 3.1.3 CHECK opening width.
- 3.1.4 SWEEP floor.

3.2 **Installing the Sensors on the Header**

NOTE

For ease of installation, the sensors should be installed onto the header *before* installing the header and jamb assembly in the opening.

- 3.2.1 PLACE header on a flat surface.
- 3.2.2 Refer to manufacturer's installation instructions, and INSTALL Optex sensors.

203974
Rev. A, 8/21/01
3 of 29

3.2.3 Refer to Stanley Access Technologies document No. 203957, "SU-100 Motion Sensor Installation and Operation," and INSTALL SU-100 motion sensors.

3.2.4 IF required, DRILL hole to receive electrical conduit.

3.3 Attaching the End Caps to the Jambs

3.3.1 REMOVE end caps from header.

3.3.2 POSITION each end cap on its corresponding jamb.

3.3.3 Refer to Figure 1, and, using five $\frac{5}{16}$ "-18 x 1" hex head bolts and lockwashers, ATTACH each end cap to its respective jamb.

3.3.4 ATTACH jamb/end cap assemblies to header.

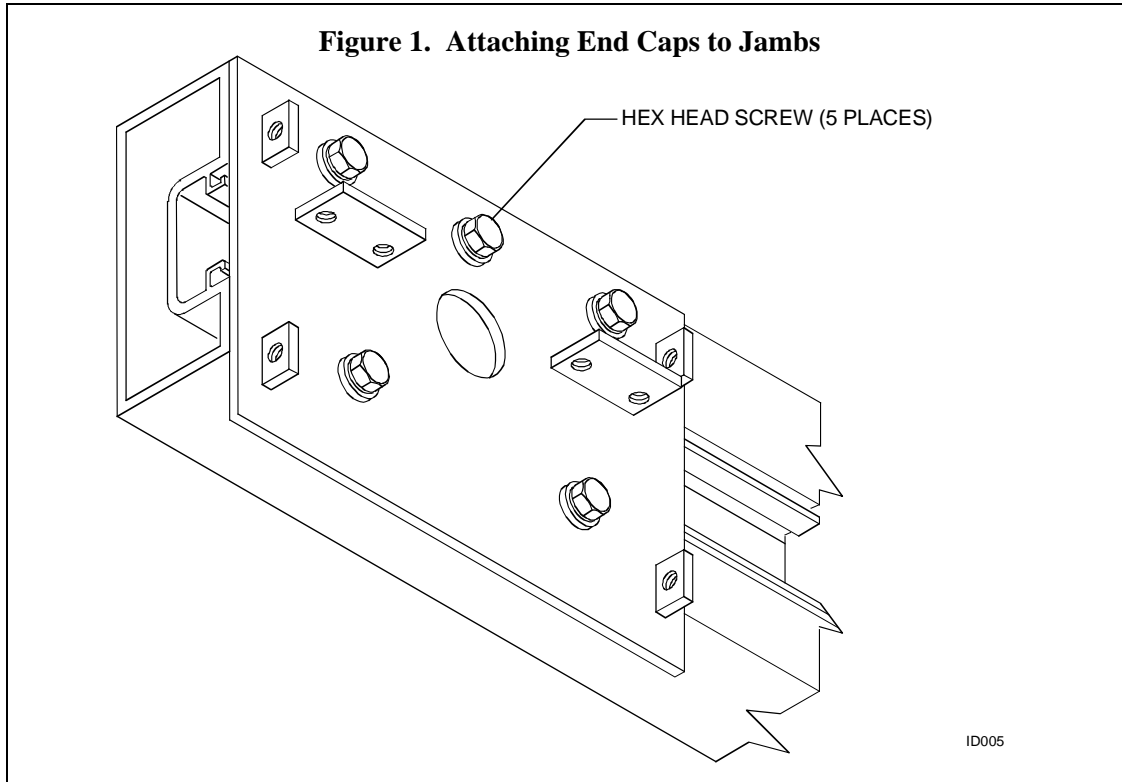

3.4 Installing the Header and Jamb Assembly

3.4.1 LIFT header and jamb assembly and POSITION assembly as follows:

- IF installing a 2000-series door, ENSURE header cover faces *exterior*.
- IF installing a 3000-series door, ENSURE header cover faces *interior*.

3.4.2 LIFT header into position.

3.4.3 Temporarily SECURE and SHIM header and jamb assembly in place as necessary to prevent assembly from falling.

3.4.4 LEVEL header and SHIM beneath jambs as necessary.

3.4.5 INSPECT jambs for plumb in vertical and horizontal planes. IF required, SHIM back of jamb.

- 3.4.6 Refer to Figure 2, and, using the predrilled holes in header and jamb assembly as a guide, DRILL holes in rough opening for the following fasteners as required:
- **IF** rough opening is concrete, DRILL a ¼" dia. hole for concrete screw, and ENSURE screw will be embedded 1½" minimum.
 - **IF** rough opening is steel, DRILL for a #14 SMS (Note 18 GA steel minimum).
 - **IF** rough opening is wood, DRILL for a #14 wood screw, and ENSURE screw will be embedded 1½" minimum.

NOTE

In order to meet the approval rating, the proper fasteners must be used in *every* predrilled location in mounting jambs, header, and threshold.

Figure 2. Fastener Locations for Header and Jamb Assembly

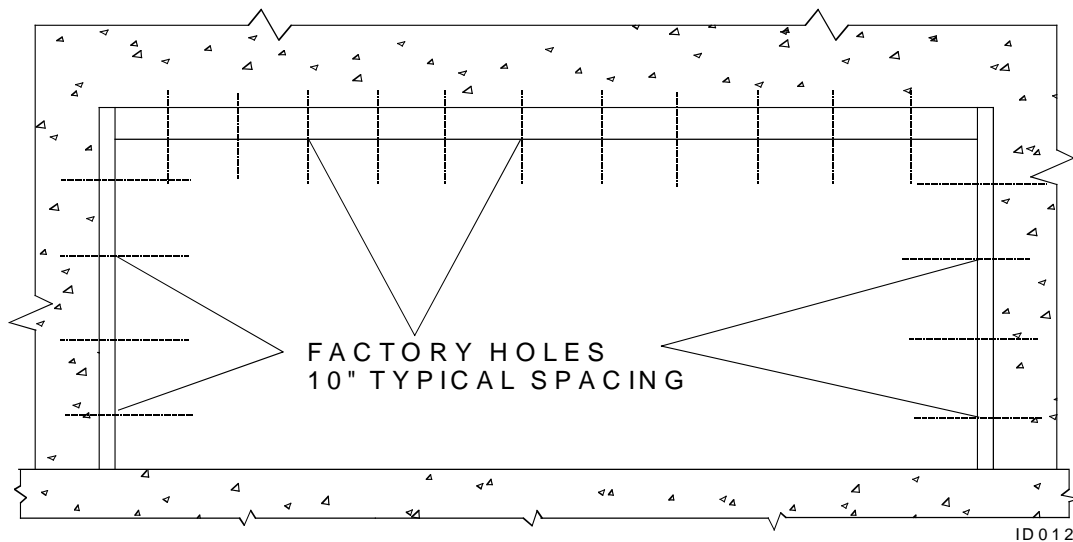

- 3.4.7 **INSTALL**, but *do not* tighten, fasteners securing one jamb to opening, and ENSURE jamb remains plumb.
- 3.4.8 Beginning at the top of the jamb and moving downward, SHIM jambs as necessary to ensure jambs remain level and plumb, and TIGHTEN fasteners securing jambs to opening.

NOTE

1. The components in the header may need to be temporarily moved in order to gain access to the header mounting holes.
2. *Do not* install jamb inserts at this time.

- 3.4.9 **INSTALL** and TIGHTEN anchors in *every* predrilled hole securing header to opening, and ENSURE the header remains level.

3.5 Installing the Threshold/Track

- 3.5.1 Refer to Figure 3, and DRILL a 1/2" hole through each predrilled hole in the center of the threshold/track for flush bolts.

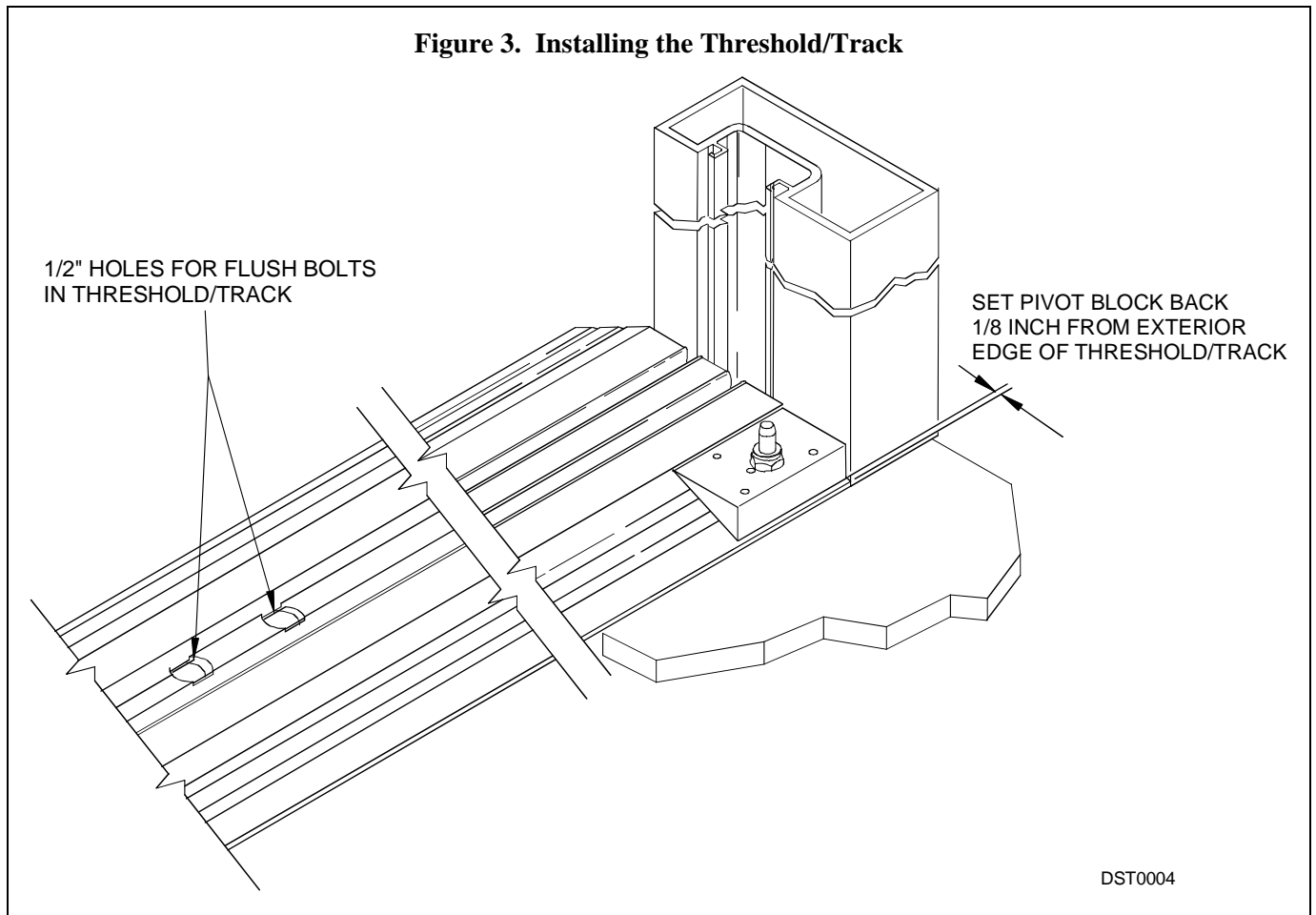

- 3.5.2 On the exterior side of the opening, POSITION the threshold/track on the floor, and ENSURE threshold/track is butted against the jamb and plumb.
- 3.5.3 WHEN threshold/track is properly aligned, MARK location and REMOVE threshold/track.

- 3.5.4 Refer to Figure 4, and **APPLY** a moderate bead of rubber sealant along the bottom center of the threshold/track.

Figure 4. Applying Sealant to Bottom of Threshold/Track

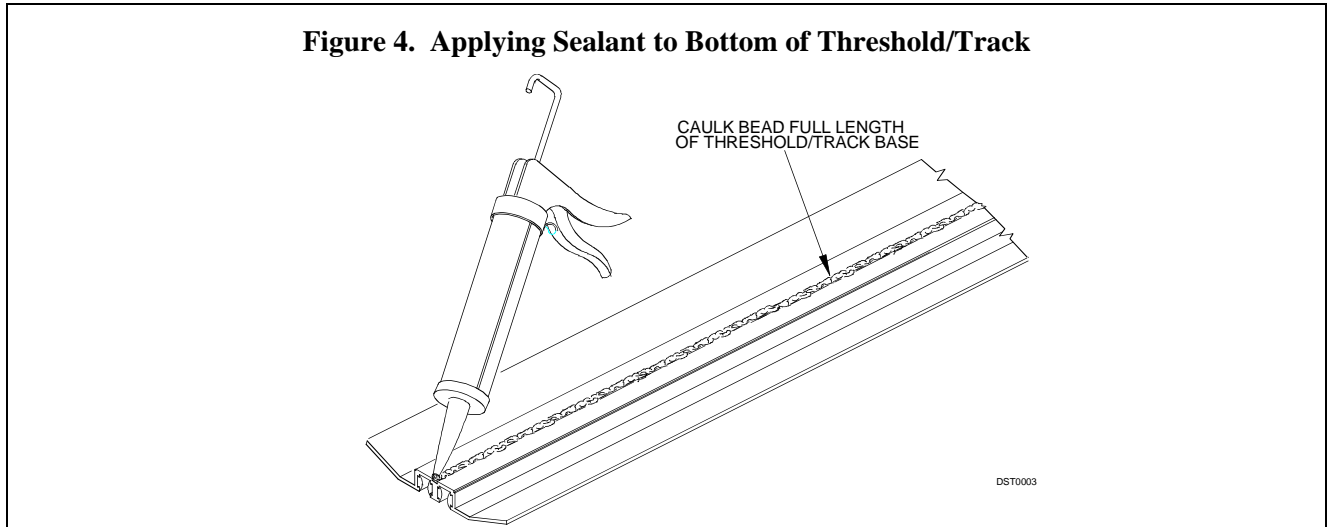

- 3.5.5 **REPOSITION** threshold/track in proper location on floor.
- 3.5.6 Using the predrilled holes in threshold/track as a guide, **DRILL** holes in floor for the following fasteners as required:
- **IF** rough opening is concrete, **DRILL** a 1/4" dia. hole for concrete screw, and **ENSURE** screw will be embedded 1 1/2" minimum.
 - **IF** rough opening is steel, **DRILL** for a #14 SMS (Note 18 GA steel minimum).
 - **IF** rough opening is wood, **DRILL** for a #14 wood screw, and **ENSURE** screw will be embedded 1 1/2" minimum.
- 3.5.7 **FASTEN** threshold/track to floor, and, using shims, **ENSURE** the following:
- Threshold/track remains level.
 - The bottom of the threshold/track is even with the bottom of the jamb.

NOTE

At this point inspection may be necessary by a local building inspector. Please check the local code in your area.

- 3.5.8 Refer to Figure 3, and **POSITION** pivot block(s) 1/8" from the exterior edge of the threshold/track.
- 3.5.9 **DRILL** through-holes into threshold/track and floor and **FASTEN** pivot block(s) to floor.
- 3.5.10 **IF** necessary, **REQUEST** local building inspector to inspect installation.

3.6 Installing the Keystrips and Angle Brackets (2000-Series Doors Only)

3.6.1 Refer to Figure 5, and MEASURE back (toward exterior) $\frac{3}{16}$ " from interior edge of threshold/track and MARK location.

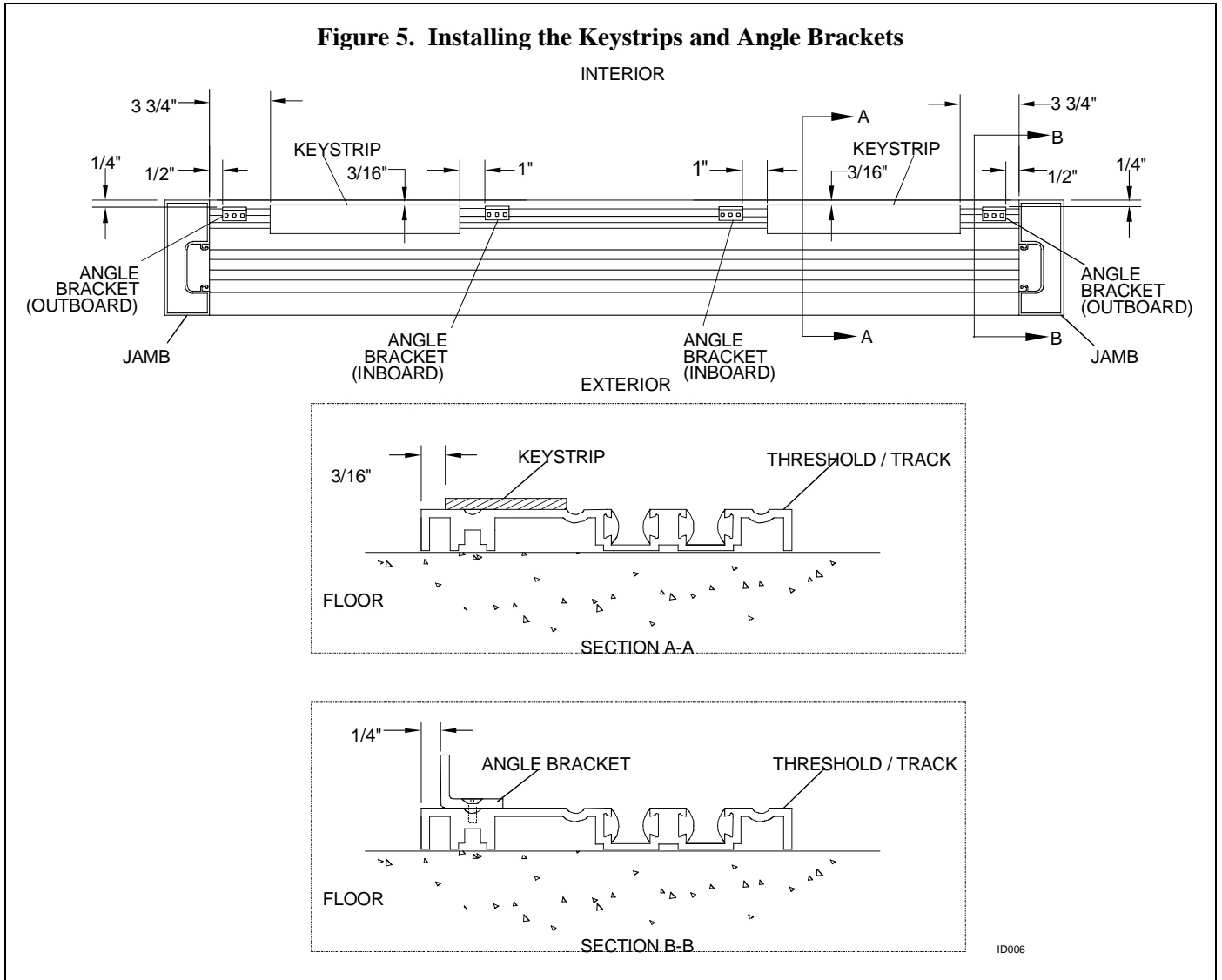

- 3.6.2 POSITION side edge of keystrips at marked location and end of keystrips $3\frac{3}{4}$ " from each jamb.
- 3.6.3 DRILL 0.169" holes (#18 drill) through keystrips and threshold/track.
- 3.6.4 Using #10-12 X $\frac{3}{4}$ " flat head sheet metal screws, FASTEN keystrips to threshold/track, and ENSURE keystrips remain level and properly aligned across opening.

3.6.5 INSTALL threshold/track angle brackets as follows:

- a. POSITION side edge of *outboard* angle brackets $\frac{1}{2}$ " from each jamb and $\frac{1}{4}$ " back from interior edge of threshold/track.
- b. POSITION side edge of *inboard* angle brackets 1" from each keystrip and $\frac{1}{4}$ " back from interior edge of threshold/track.
- c. DRILL 0.169" holes (#18 drill) through angle brackets and threshold/track.
- d. Using #10-12 X $\frac{3}{4}$ " flat head sheet metal screws, FASTEN angle brackets to threshold/track.

3.7 Installing the O Panels (2000-Series Doors Only)

3.7.1 Refer to Figure 6, and POSITION O panel over keystrip and angle brackets.

Figure 6. Installing the O Panel

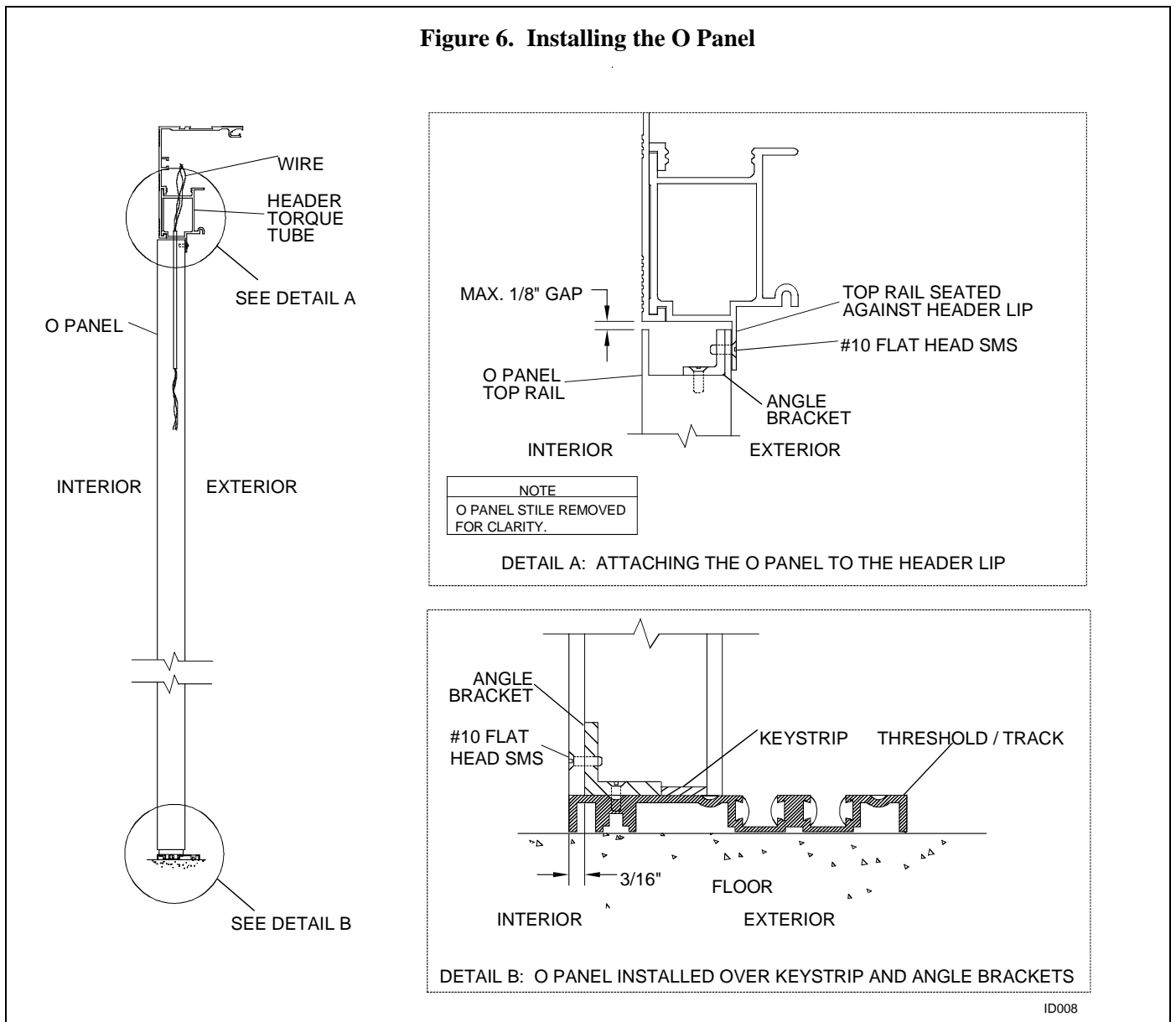

- 3.7.2 Carefully ROUTE doorway holding beam and breakout switch wiring from lead stile through header torque tube.
- 3.7.3 POSITION panel against jamb.
- 3.7.4 CLAMP O panel to header lip.
- 3.7.5 MEASURE gap between top of O panel and bottom of header.
- 3.7.6 IF gap between top of O panel and bottom of header is *greater than* $\frac{1}{8}$ " , PERFORM the following:
 - a. REMOVE clamp securing O panel to header lip.
 - b. REMOVE O panel.
 - c. REMOVE keystrip from threshold/track.
 - d. SHIM beneath keystrip as required to maintain maximum $\frac{1}{8}$ " gap between top of O panel and bottom of header.
 - e. FASTEN keystrip to threshold/track, and ENSURE keystrip remains level.
- 3.7.7 IF gap between top of O panel and bottom of header is $\frac{1}{8}$ " or less, PERFORM the following:
 - a. REMOVE clamp securing O panel to header lip.
 - b. LIFT and MOVE O panel as necessary to access the keystrip.
- 3.7.8 APPLY a bead of caulk along top center of keystrip.
- 3.7.9 POSITION O panel over keystrip and angle brackets.
- 3.7.10 Carefully ROUTE doorway holding beam and breakout switch wiring from lead stile through header torque tube.
- 3.7.11 POSITION panel against jamb, and ENSURE panel is plumb.
- 3.7.12 CLAMP O panel to header lip.
- 3.7.13 Using the predrilled holes in the header lip as a guide, DRILL 0.169" holes (#18 drill) O panel top rail and O panel angle bracket.
- 3.7.14 Using #10-12 X $\frac{3}{4}$ " flat head sheet metal screws, FASTEN O panel to header lip.
- 3.7.15 Using the predrilled holes in the bottom of the O panel stiles and rail as a guide, DRILL 0.169" holes (#18 drill) through threshold/track angle brackets.
- 3.7.16 Using #10-12 X $\frac{3}{4}$ " flat head sheet metal screws, FASTEN O panel stiles to threshold/track angle brackets.

3.8 Applying Foam Sealant to the Frame

WARNING

To prevent injury, wear eye protection and latex gloves when applying foam sealant.

CAUTION

1. For jambs containing a rotary switch, do *not* apply foam from the height of the switch to the top of the door package on the switch side.
2. Do *not* overfill cavities. Foam continues to expand several hours after application.

3.8.1 Refer to Figure 7, and INSERT foam can nozzle into the area between jamb cavity and header end cap.

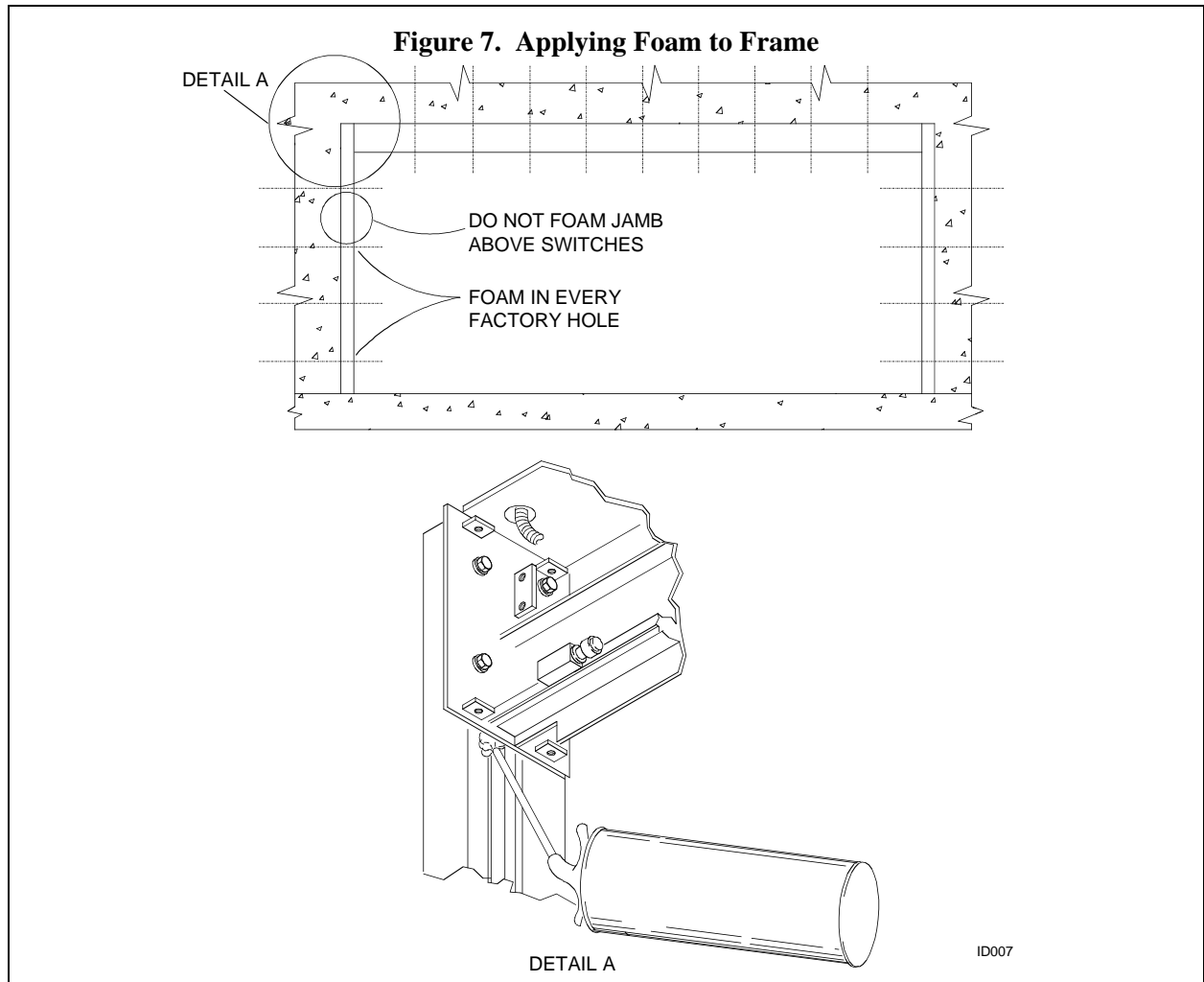

3.8.2 POINT nozzle upward and APPLY foam as follows:

- Do *not* apply foam from the height of the switches to the top of the door package on the switch side.
- Apply foam until foam begins to come out of unused holes, but do *not* overfill.

3.8.3 POINT nozzle downward and repeat application process.

3.8.4 REPEAT foam application process for opposite side of door package.

203974

Rev. A, 8/21/01

11 of 29

- 3.8.5 INSERT nozzle into each jamb mounting hole and perform the following:
- POINT nozzle upward and APPLY foam, but do *not* overfill.
 - POINT nozzle downward and APPLY foam, but do *not* overfill.
- 3.8.6 INSTALL jamb inserts.

3.9 **Installing the SO Panels (3000-Series Doors Only)**

- 3.9.1 INSTALL bottom pivot pin into threshold/track.
- 3.9.2 ADJUST bottom pivot height as necessary to maintain a $\frac{1}{8}$ " nominal gap at bottom of door.
- 3.9.3 ENSURE door opens without interference throughout 90-degree swing.
- 3.9.4 Refer to Figure 8, and *carefully* ROUTE holding beam wires through the header torque tube.

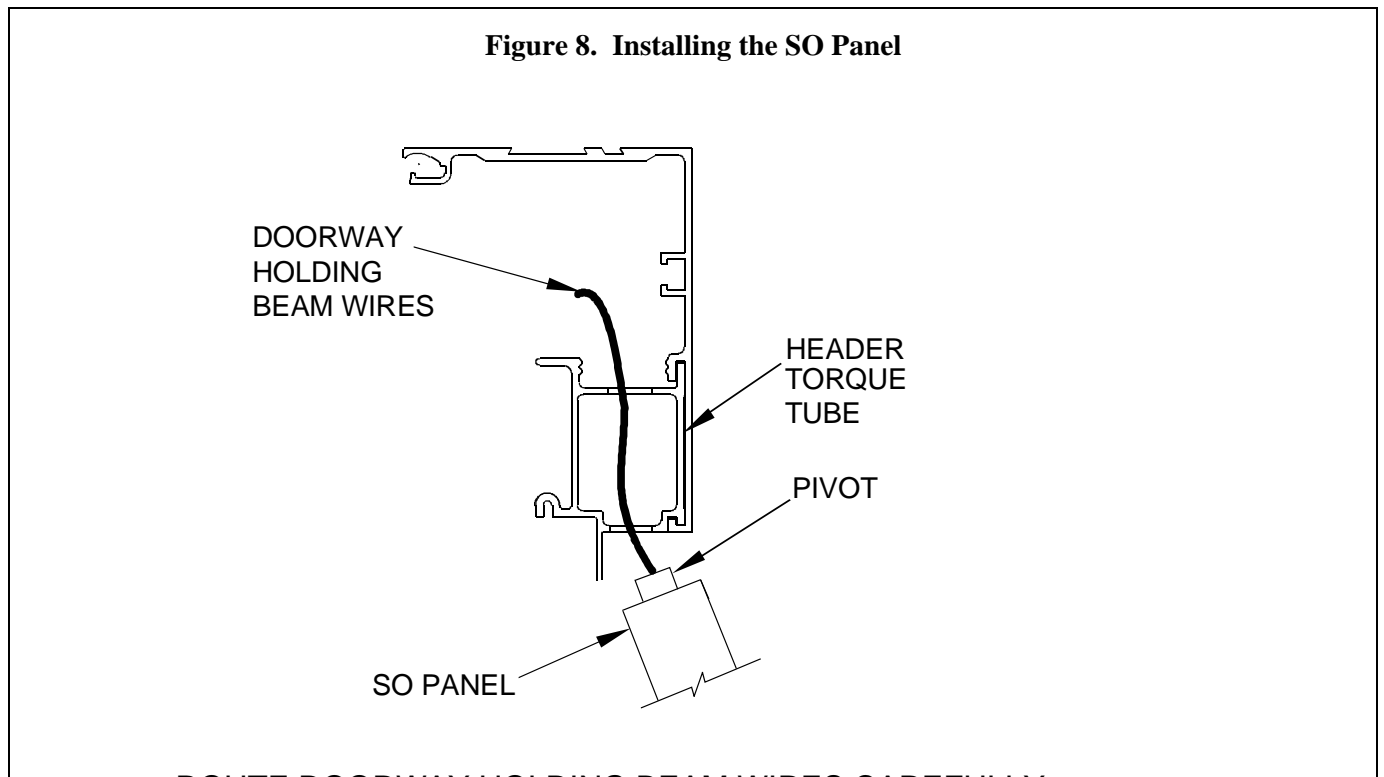

ROUTE DOORWAY HOLDING BEAM WIRES CAREFULLY THROUGH HEADER TORQUE TUBE.

- 3.9.5 ALIGN the bottom pivot pin with the bottom pivot in the door.
- 3.9.6 ALIGN the top pivot with pivot hole in the header.

DST009

NOTE

The pivot should snap up when the locking setscrew is loosened. However, it may be necessary to pull the pivot up.

- 3.9.7 LOOSEN locking setscrew and ENSURE pivot snaps up and engages into the header hole.
- 3.9.8 TIGHTEN locking setscrew.

203974
Rev. A, 8/21/01
12 of 29

3.9.9 Refer to Figure 9, and LOOSEN two screws securing the top rail mount pivot.

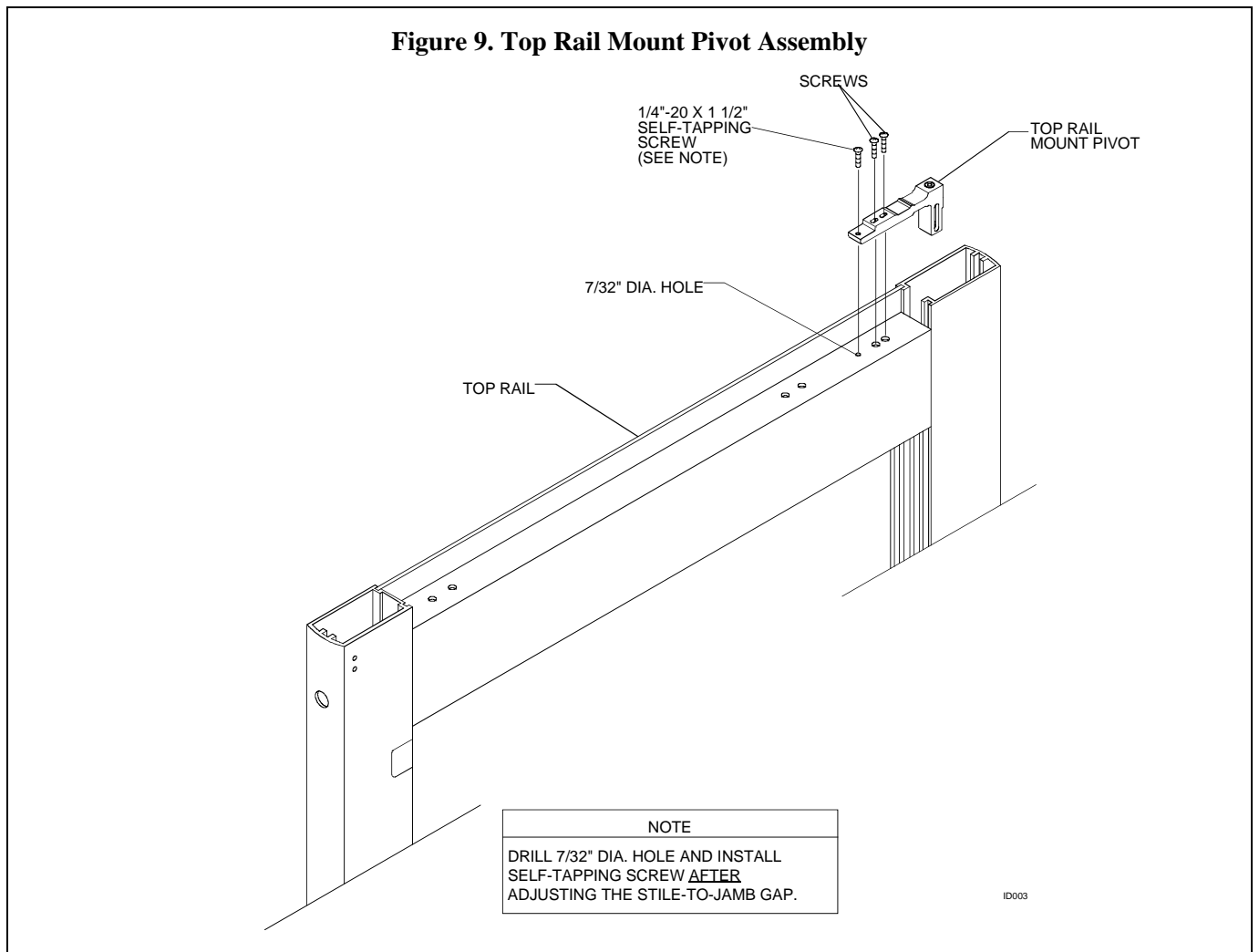

3.9.10 ALIGN the panel and jamb as necessary to maintain an even gap, and TIGHTEN the two screws securing the top rail mount pivot.

CAUTION

The stile-to-jamb gap must be adjusted *before* drilling the 7/32" hole in the top rail.

3.9.11 Using the existing hole in the top rail mount pivot as a guide, DRILL a 7/32" hole into top rail.

3.9.12 Using a 1/4"-20 X 1 1/2" self-tapping screw, FASTEN top rail mount pivot to top rail.

3.10 Installing the Wind-Resistant Damper Assembly (3000-Series Doors Only)

3.10.1 Refer to Figure 10, and, using the supplied ¼"-20 X 1" socket head cap screws and tapped holes, SECURE damper assembly to top rail of door panel.

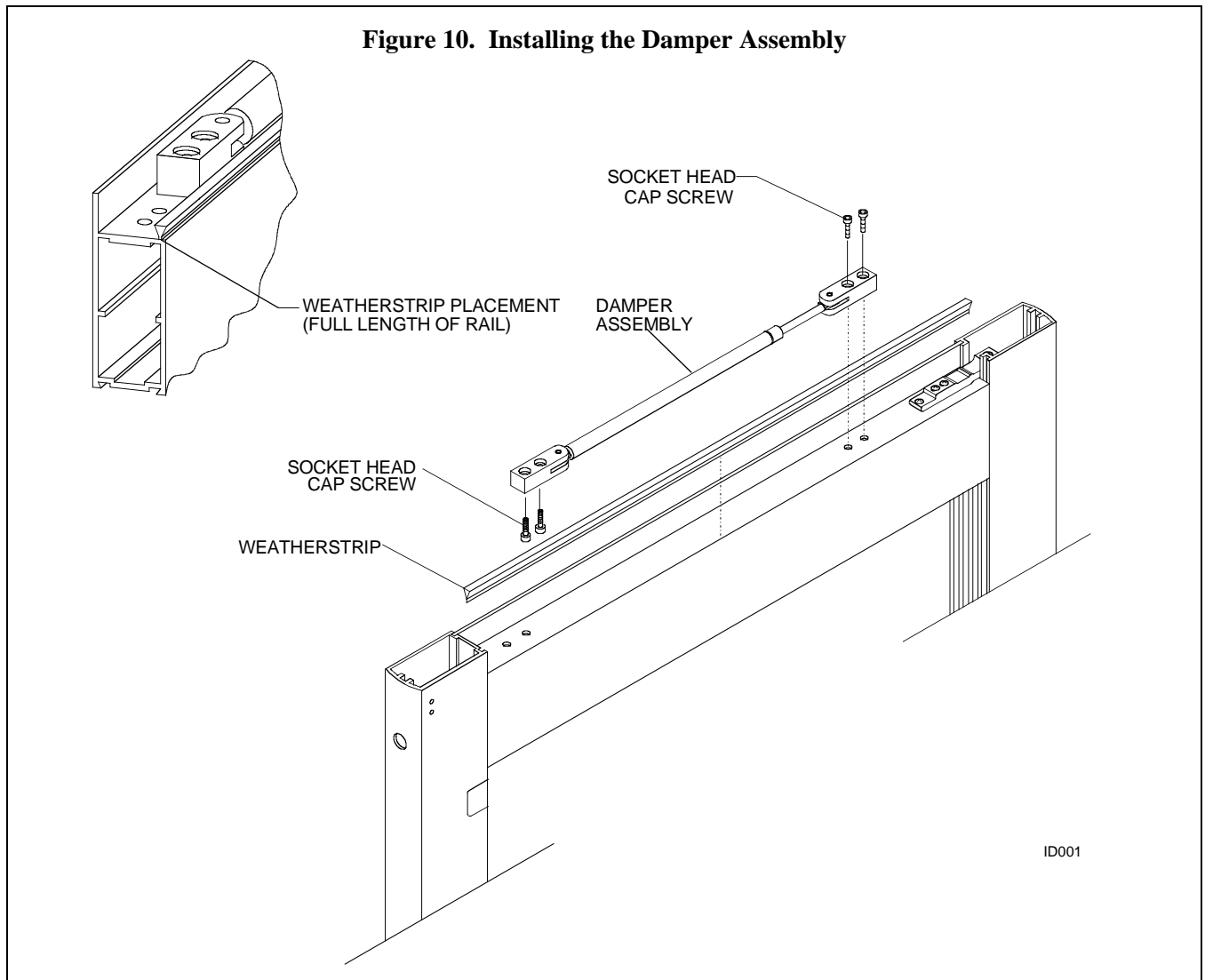

3.10.2 Using the supplied ¼"-20 X 1" socket head cap screws, SECURE damper assembly to header.

3.10.3 Refer to doorway holding beam manufacturer's installation instructions and CONNECT doorway holding beam wiring.

3.11 Installing the SX Panels

3.11.1 Refer to Figure 11, and LOOSEN nuts securing the load wheels and anti-riser wheels to the hanger.

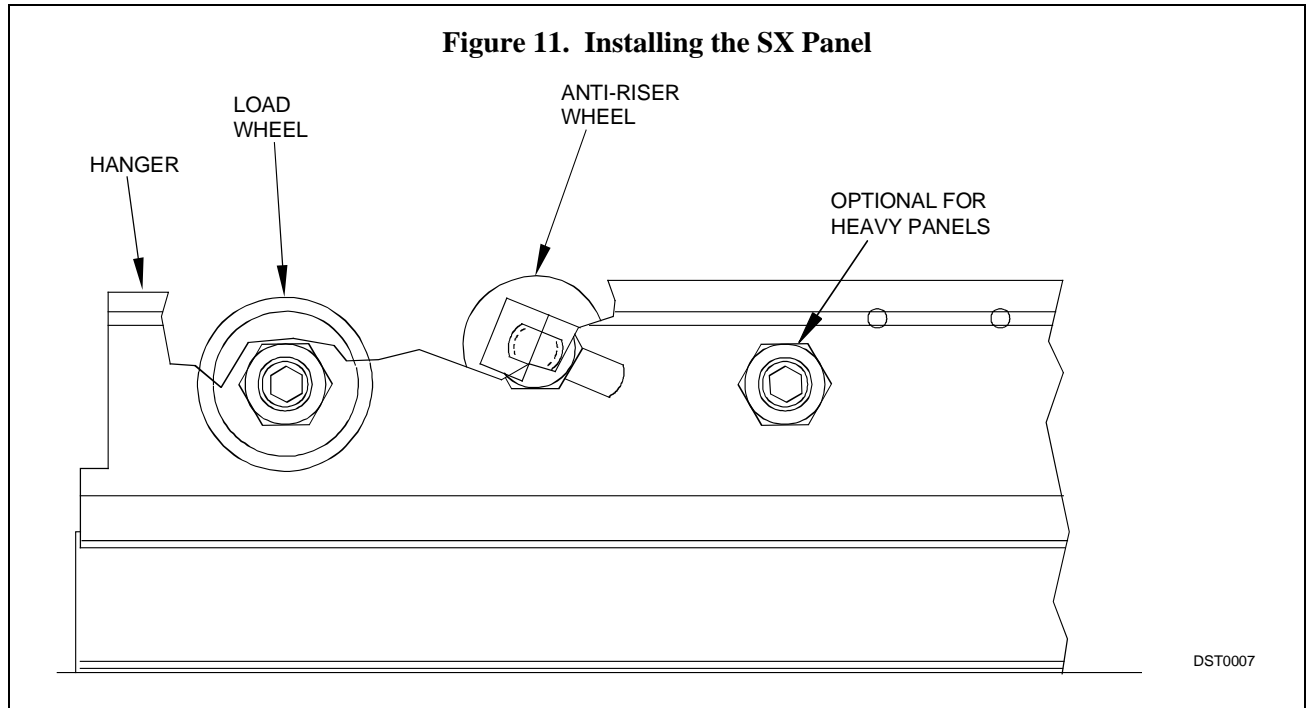

3.11.2 MOVE the anti-riser wheels to the lowest position in the hanger.

3.11.3 Using an Allen wrench, SET the load wheels to the lowest position in the hanger.

3.11.4 TIGHTEN the nuts securing the load wheels and anti-riser wheels to the hanger.

WARNING

Whenever the door anti-riser wheels are not set, there is a possibility that the panel could fall off the hanger track. Use extreme caution when handling the SX panels

3.11.5 **IF** installing a 2000-series door, Refer to Figure 12, and HANG the SX panel on the header track as follows:

Figure 12. Hanging the SX Panel on the Header Track (3000-Series Door)

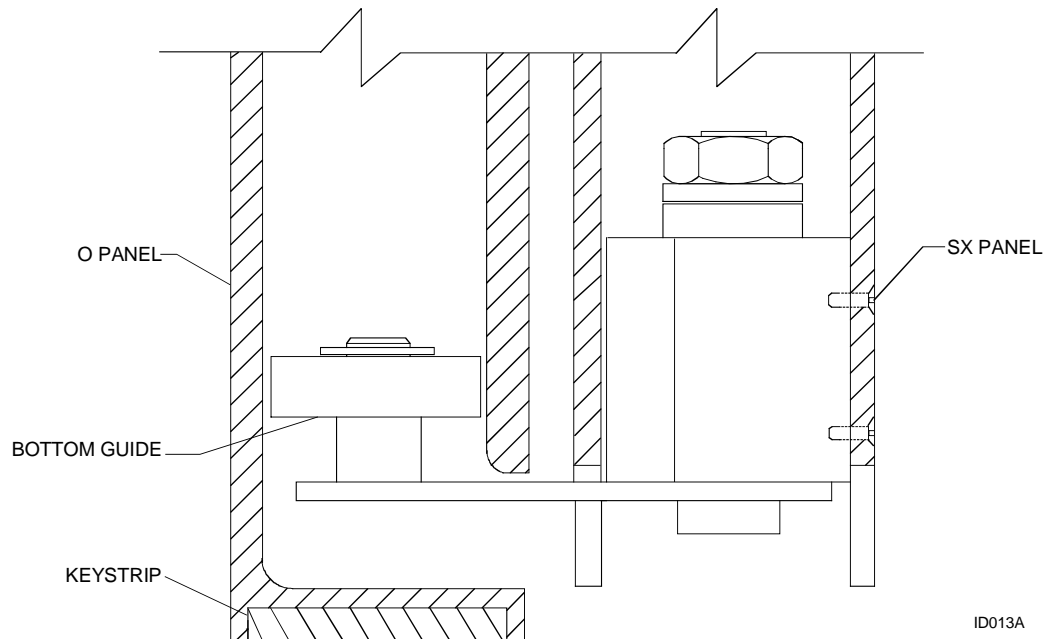
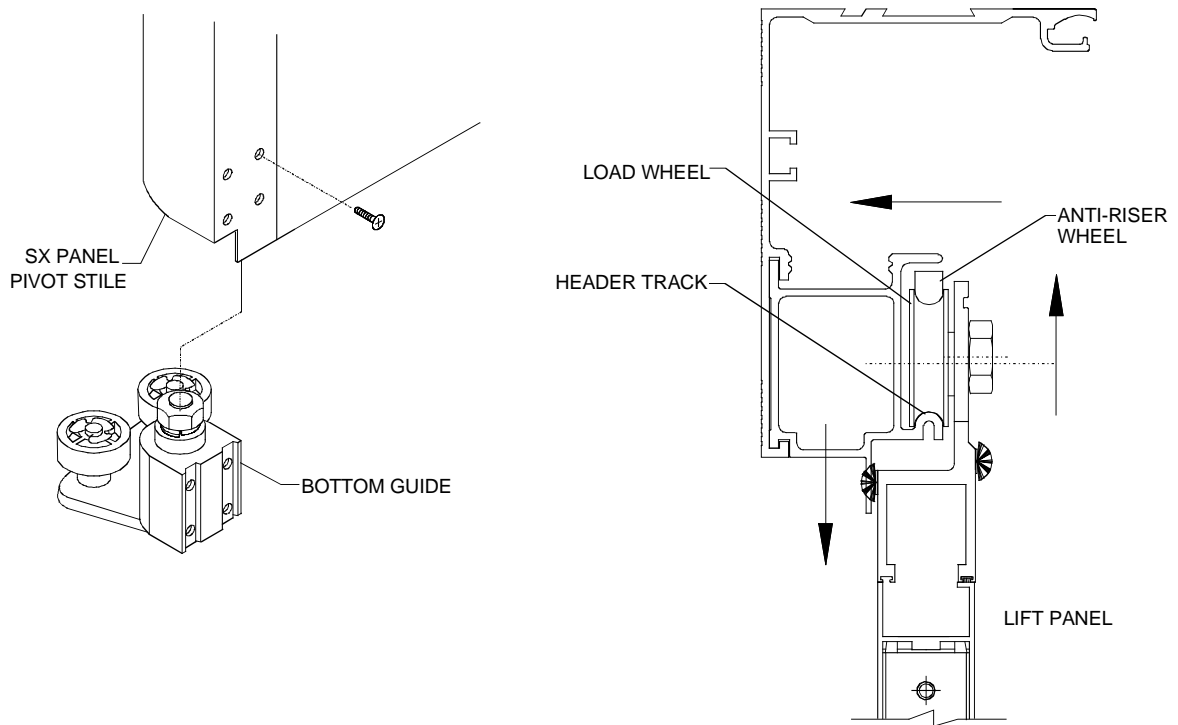

ID013A

203974
Rev. A, 8/21/01
16 of 29

- a. INSERT the bottom guide into the SX panel pivot stile.
 - b. Using the four #10-32 X $\frac{3}{8}$ " flat head hex socket screws provided, FASTEN bottom guide to panel.
 - c. POSITION SX panel so bottom guide rollers engage into O panel trailing stile cutout.
 - d. LIFT the SX panel up over the header track and carefully position the panel onto the header track.
- 3.11.6 **IF** installing a 3000-series door, Refer to Figure 13, and HANG the SX panel on the header track as follows:
- a. LIFT the panel up over the header track and carefully position the panel onto the header track.
 - b. INSERT the bottom guide into the threshold/track.

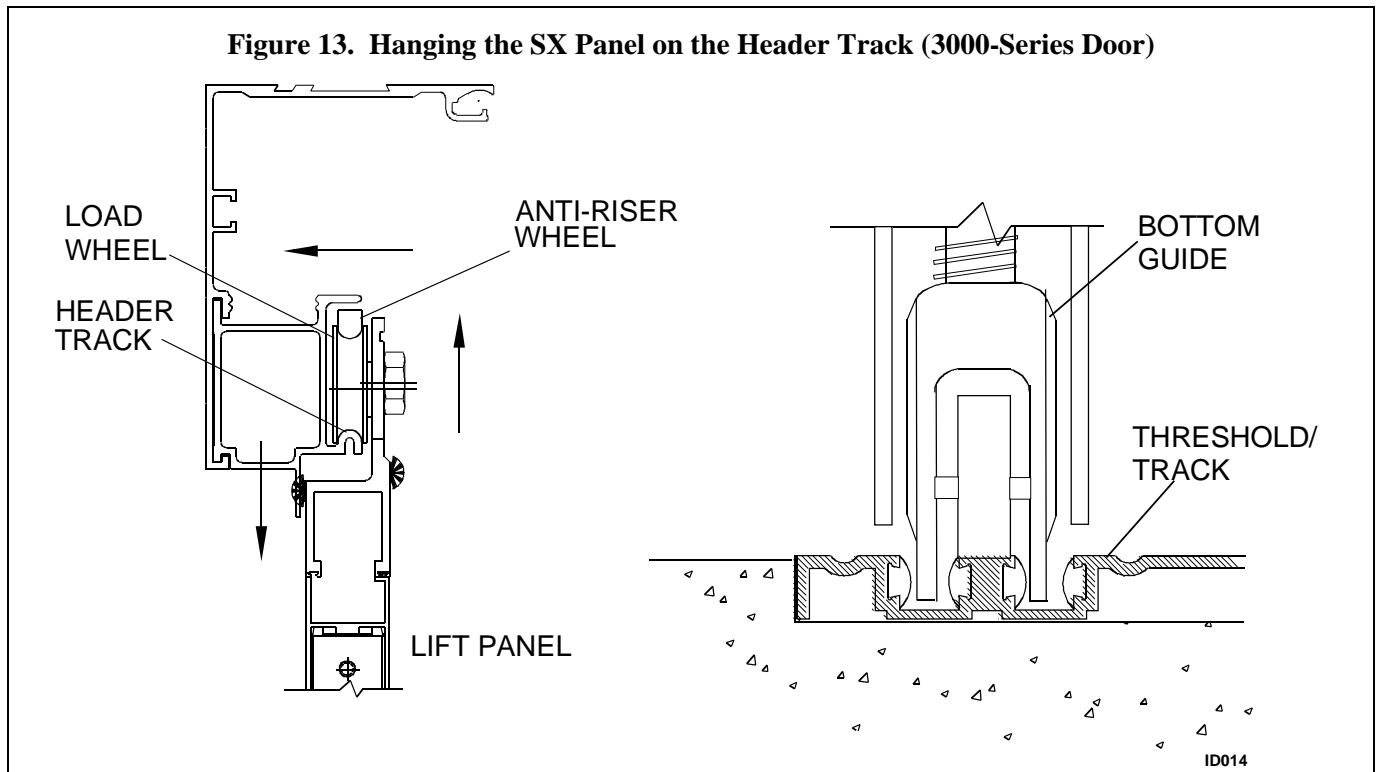

- 3.11.7 FASTEN the belt brackets to the hangers as follows:
- a. CLOSE door.

NOTE

When looking into the header from the cover side, the long bracket attaches to the left SX panel and the short bracket attaches to the right SX panel.

- b. FASTEN the long bracket to the left SX panel hanger.
- c. FASTEN the short bracket to the right SX panel hanger.

3.12 Adjusting the SX Panels

3.12.1 Refer to Figure 11, and ADJUST SX panel height as follows:

- a. LOOSEN the nuts securing the upper load wheels to the hanger.

NOTE

Each load wheel is an eccentric that permits adjustment of the threshold/track-to-panel gap. The total adjustment available from the load wheels is approximately $\frac{5}{16}$ ".

- b. Using an Allen wrench, TURN the load wheels until the following occur:

- Threshold/track-to-panel gap is even across the entire bottom of the door panel.
- The stiles of both door panels meet and are parallel with no gap at the top or bottom.

- c. WHEN adjustment is complete, TIGHTEN nuts securing load wheels to hanger.

NOTE

The anti-riser wheel adjustment is performed to prevent the door panel from moving upward. The anti-riser track serves as a roller surface for the anti-riser wheels.

3.12.2 ADJUST the anti-riser wheels as follows:

- a. LOOSEN nuts securing the anti-riser wheels to the hanger.
- b. SLIDE the anti-riser wheels upward in the hanger until there is a $\frac{1}{64}$ "-to- $\frac{1}{32}$ " gap between the top of the anti-riser wheels and the bottom of the anti-riser track.
- c. TIGHTEN the nuts securing the anti-riser wheels to the hanger.

3.13 Verifying that the SX Panels are Centered

NOTE

1. On 2000-series doors the pivot stiles of the SX panels and the lead stiles of the O panels must be aligned vertically.
2. On 3000-series doors the pivot stiles of the SX panels and the lead stiles of the SO panels must be aligned vertically. This ensures that the security hooks will engage properly on both sides and that the flush bolt rods are aligned with the holes in the threshold/track.

3.13.1 CLOSE the doors.

3.13.2 Visually INSPECT vertical alignment of panel stiles.

3.13.3 IF panel stiles are *not* vertically aligned, PERFORM the following:

- a. RECORD dimension of misalignment.
- b. Viewing from the cover side of header, MARK position of left gear reducer/idler pulley on header mounting track.
- c. LOOSEN fastener(s) securing left gear reducer/idler pulley to header mounting track.
- d. TURN belt tension adjusting screw as necessary to reduce belt tension.

203974

Rev. A, 8/21/01

18 of 29

NOTE

In order to correct misalignment, the gear reducer/idler pulley must be moved one half the distance of the recorded misalignment. For example, if the panel stiles were misaligned by $\frac{3}{4}$ ", the gear reducer/idler pulley must be moved $\frac{3}{8}$ ".

- e. MOVE left gear reducer/idler pulley by one half of the recorded misalignment dimension.
- f. TIGHTEN fasteners securing left gear reducer/idler pulley to header mounting track.
- g. INSPECT vertical alignment of panel stiles, and REPEAT step 3.13.3 as necessary.
- h. TURN the belt tension adjusting screw to increase the belt tension.
- i. WHEN panel stiles are aligned, refer to Section 3.14 and ADJUST belt tension.

3.14 Adjusting Belt Tension

- 3.14.1 Refer to Figure 14, and, facing cover side of header, OPEN doors until "Dimension B" between short bracket and center of gear reducer drive pulley is 28".

Figure 14. Adjusting Belt Tension

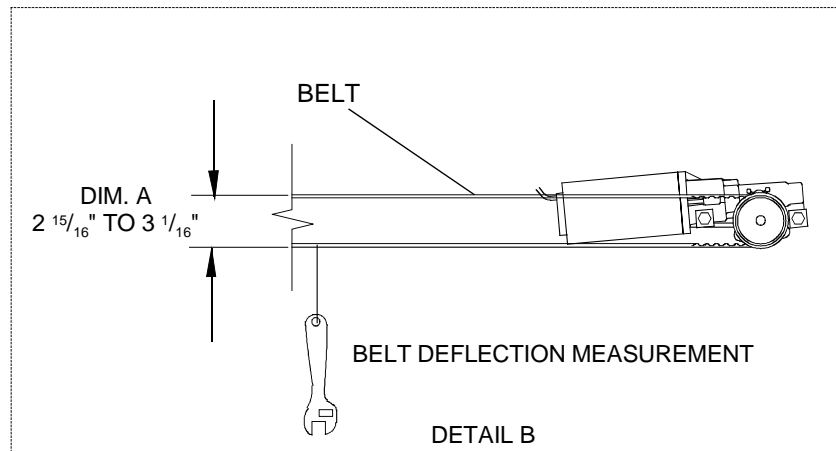
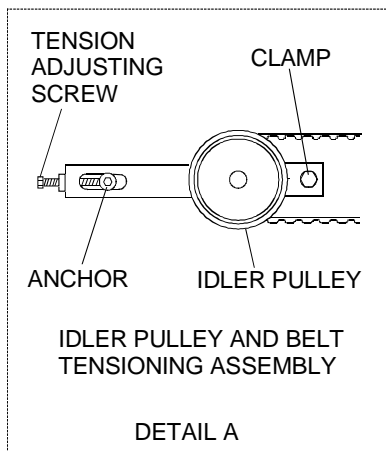
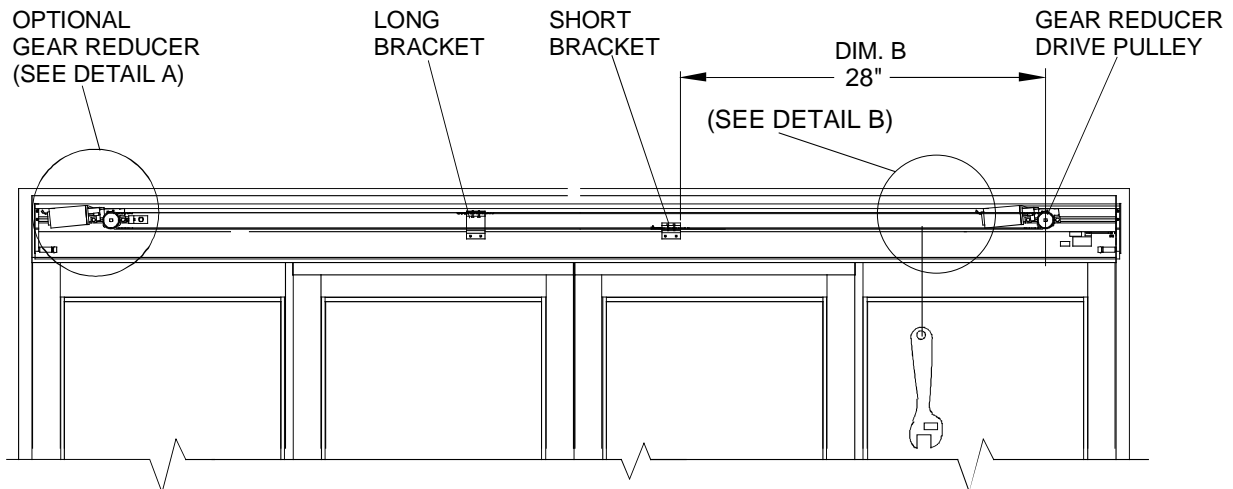

DGHD007

203974
Rev. A, 8/21/01
19 of 29

- 3.14.2 At the center of "Dimension B", HANG a 1½ lb. weight (or 12" crescent wrench) from lower portion of belt.
- 3.14.3 MEASURE "Dimension A" from top of belt to bottom of belt.

CAUTION

Over long spans, some belt deflection is required. To prevent damage to bearings and gear reducer, belt must *not* be overtightened.

- 3.14.4 IF "Dimension A" is *not* 2¹⁵/₁₆" to 3¹/₁₆", PERFORM the following:
- LOOSEN fastener(s) securing left gear reducer/idler pulley to header mounting track.
 - TURN belt tension adjusting screw as necessary to achieve proper belt deflection.
 - WHEN belt tension is fully adjusted, TIGHTEN fastener(s) securing left gear reducer/idler pulley to header mounting track.

3.15 Adjusting the Full-Open Bumper Stops

- 3.15.1 Refer to Figure 15, and LOOSEN bumper stop locknut.

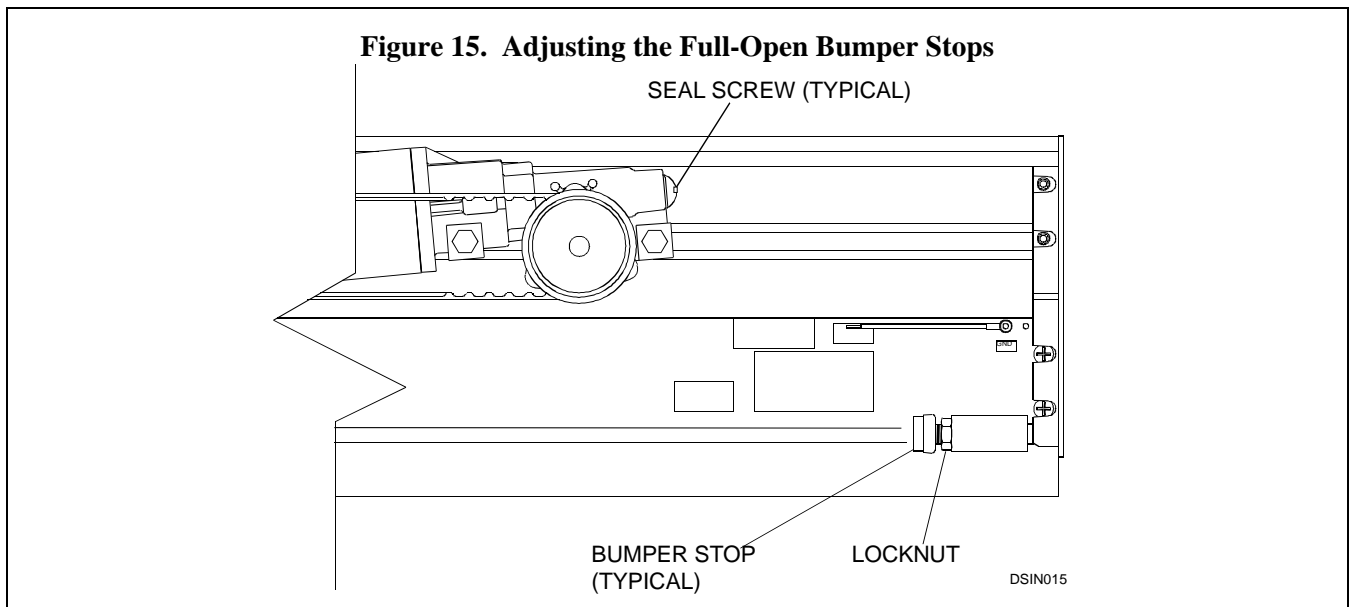

- 3.15.2 THREAD bumper stop to full-in position.
- 3.15.3 Manually OPEN doors to full open position, and TURN bumper stop as necessary to ensure both SX panels contact bumper stops at the same time.
- 3.15.4 WHEN adjustment is complete, TIGHTEN bumper stop locknuts.

CAUTION

Each gear reducer has a seal screw that prevents the leakage of oil during shipping and handling. To prevent the buildup of pressure and subsequent oil leakage through the seals, the seal screw must be loosened *prior to operating the unit*. After pressure has been relieved, the seal screw must be retightened to prevent oil leakage from the bleed hole. Before removing the gear reducer for service, make sure the seal screw is tightened to prevent oil spillage during handling or shipment.

- 3.15.5 LOOSEN gear reducer seal screw from gear reducer(s), and ALLOW release of pressure from gearbox.
- 3.15.6 After pressure has been released, TIGHTEN gear reducer seal screw.

3.16 Installing the SX Panel Damper Assembly (2000-Series Doors Only)

- 3.16.1 Refer to Figure 16, and using the self-tapping hex-head screws provided, FASTEN the damper assembly to the SX panel top rail.

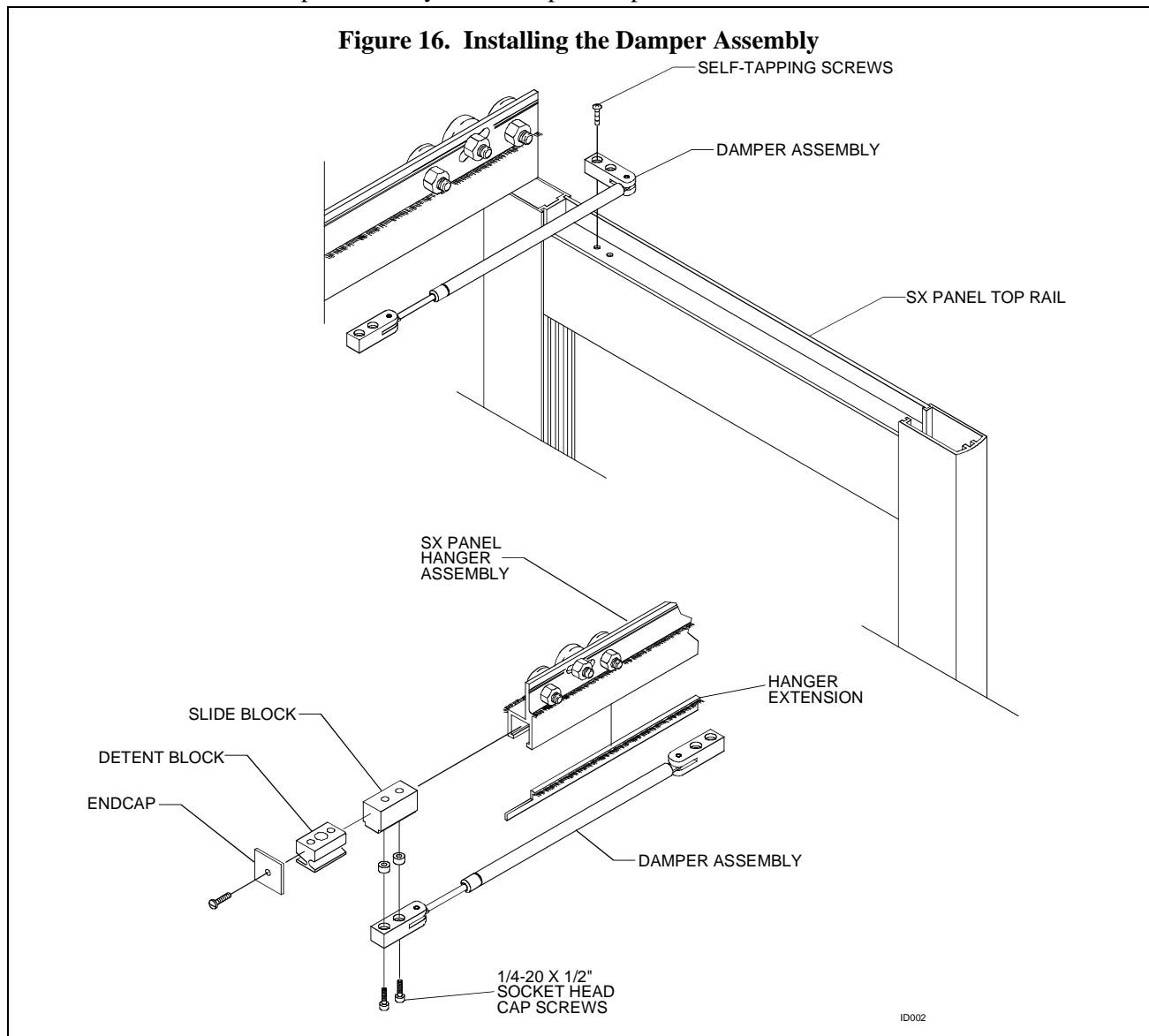

203974
Rev. A, 8/21/01
21 of 29

- 3.16.2 LOOSEN, but do *not* remove, the setscrews securing the slide block in the hanger assembly.
- 3.16.3 Using the two socket head capscrews provided, FASTEN damper assembly to slide block.
- 3.16.4 OPEN the SX panel to the 90-degree open breakout position.
- 3.16.5 EXTEND the damper to its maximum length while moving the slide block in the hanger track.
- 3.16.6 With the damper fully extended and the SX panel at 90-degree open position, MARK the location of the slide block in the hanger track.
- 3.16.7 REMOVE the two socket head capscrews securing the damper assembly to the slide block.
- 3.16.8 ALIGN the slide block with the hanger mark made in step 3.16.6, and TIGHTEN the setscrews securing the slide block in the hanger assembly.
- 3.16.9 Using the two socket head capscrews provided, FASTEN damper assembly to slide block.

3.17 Adjusting the SX Panel Emergency Egress Breakout Detents

NOTE

1. Breakout detents are factory set to average requirements. If more or less breakout force is required to open the door, the breakout detents can be adjusted.
2. During door installation, the breakout detents are set tight to prevent the door from swinging out and being damaged. During door tune-in, the breakout detents must be readjusted to meet ANSI Standard A156.10 requirements.

- 3.17.1 BREAK OUT panel.
- 3.17.2 Refer to Figure 17, and LOOSEN two fasteners in bottom of detent block.

Figure 17. Adjusting Emergency Egress Breakout Detents

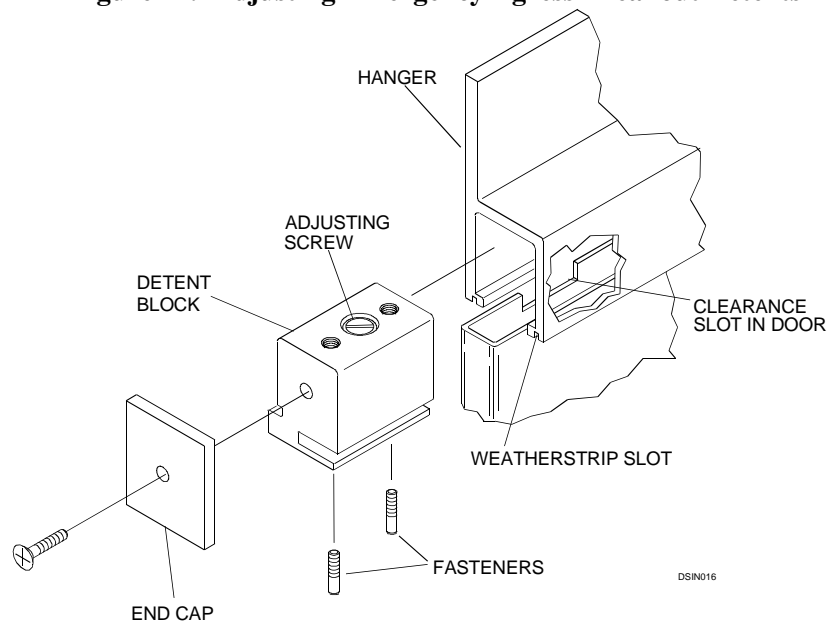

203974
Rev. A, 8/21/01
22 of 29

- 3.17.3 REMOVE end cap and detent block from hanger.
- 3.17.4 INSTALL weatherstrips in exterior and interior channel of hanger, and CUT weatherstrip to length.

NOTE

Turning adjusting screw clockwise increases the force required to break out door. Turning adjusting screw counterclockwise decreases the force required to break out door.

- 3.17.5 TURN adjusting screw in top of detent block as necessary to ensure door will be tight.
- 3.17.6 SLIDE detent block and end cap into hanger, and ENSURE detent block is aligned with clearance slot in door.
- 3.17.7 TIGHTEN two fasteners in bottom of detent block.
- 3.17.8 With "TOP" indication facing upward, POSITION end cap over hanger.
- 3.17.9 TIGHTEN fastener securing end cap to detent block.
- 3.17.10 APPLY pressure-sensitive foam to end cap.

3.18 Adjusting the SO Panel Ball Detents (3000-Series Doors Only)

NOTE

1. The instructions for adjusting the top and bottom ball detents are the same for either SO panel.
2. During door installation, the ball detents are set tight to prevent the door from swinging out and being damaged. During door tune-in, the ball detents must be readjusted to meet ANSI Standard A156.10 requirements.

- 3.18.1 Refer to Figure 18, and LOOSEN locknut securing ball detent in SO panel stile.

Figure 18. Adjusting SO Panel Ball Detents

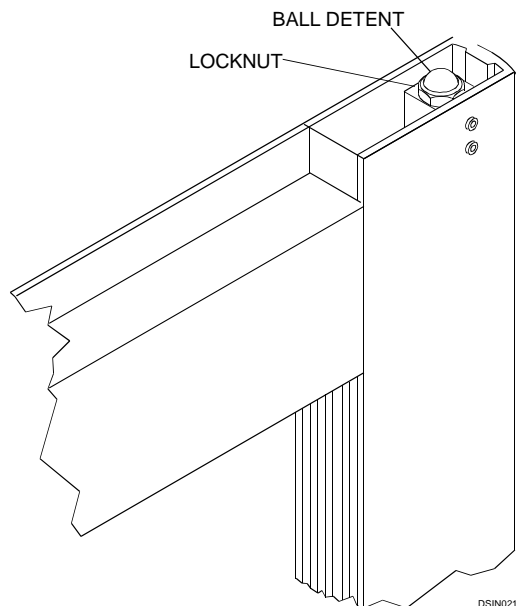

- 3.18.2 TURN ball detent as necessary to ensure door will be tight.

203974
Rev. A, 8/21/01
23 of 29

3.18.3 WHEN adjustment is complete, **TIGHTEN** locknut securing ball detent in SO panel stile.

3.18.4 **CLOSE** SO door.

3.19 Installing Glass in the Door Panel

CAUTION

To ensure proper installation, glaze the lower section of the door first; then glaze the upper section.

3.19.1 With door panel hung and in partially open position, **POSITION** a wedge beneath the lead stile as necessary to keep the door steady during glass installation.

3.19.2 **REMOVE** inside glass stops from panel.

3.19.3 Refer to Figure 19, and **POSITION** setting blocks onto outside glass stop approximately 2" from panel stiles.

Figure 19. Installing Glass in the Door Panel

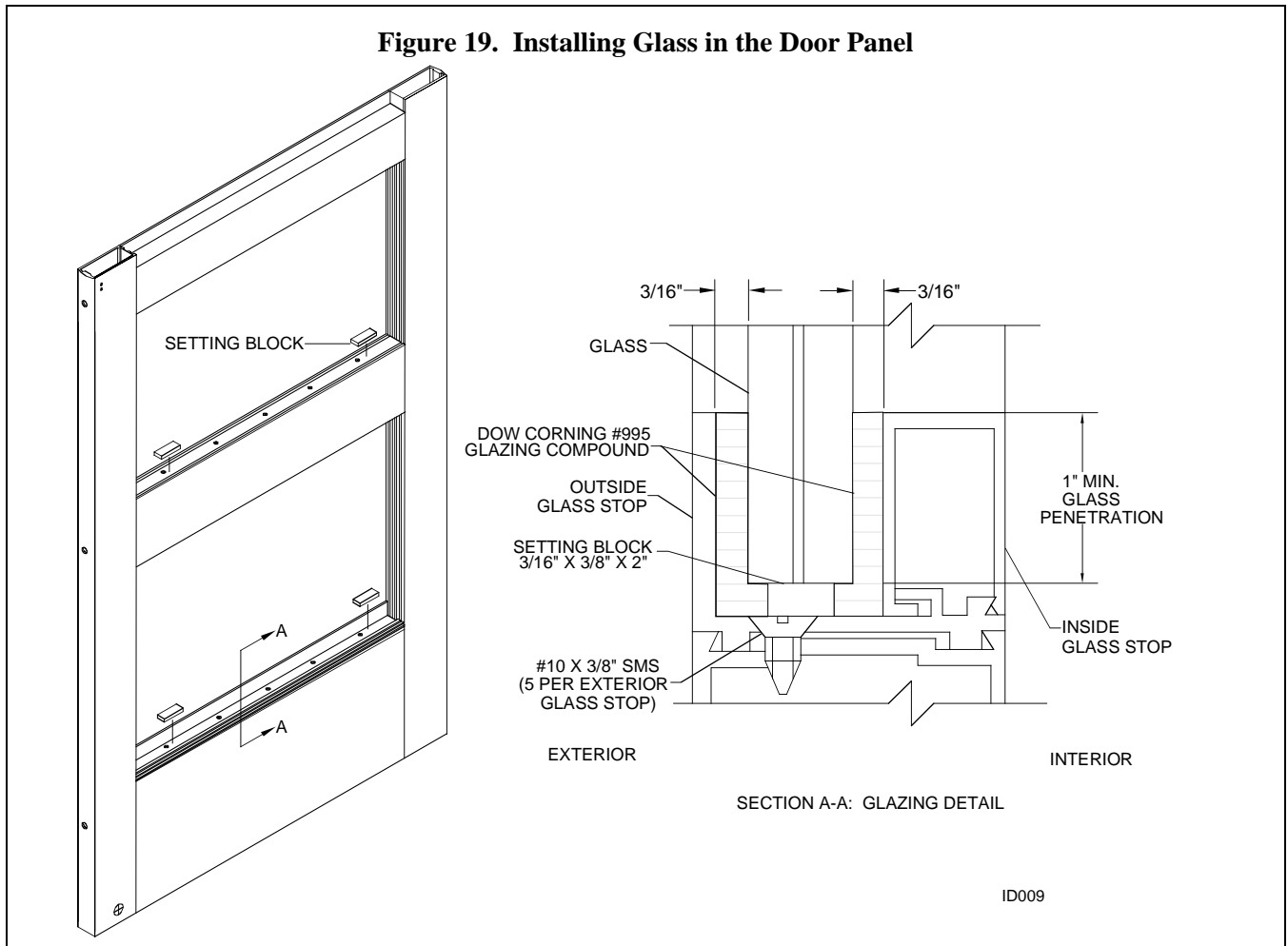

203974
Rev. A, 8/21/01
24 of 29

WARNING

1. Glass *must* be $\frac{9}{16}$ " , impact-rated (2 pcs. $\frac{1}{4}$ " clear, annealed glass with 0.070 interlayer polycarbonate). This material is supplied by Security Impact Glass, 6555 Garden Road, Suite 1, Riviera Beach, FL 33404 (561) 844-3100 Fax: (561) 848-9271. No substitute product is permitted.
2. Extreme caution must be used whenever transporting and installing glass.

- 3.19.4 Using suction cups, carefully POSITION glass pane onto setting blocks.
- 3.19.5 MOVE glass pane towards exterior until glass contacts outside glass stop.
- 3.19.6 INSTALL inside glass stops.
- 3.19.7 Using a $\frac{3}{16}$ " thick setting block as a gage, CENTER glass between inside and outside glass stops, and ENSURE there is a $\frac{3}{16}$ " gap on each side of glass.
- 3.19.8 APPLY Dow Corning #995 glazing compound around setting blocks and glass, and ENSURE the following:
 - Glazing compound is not applied too fast
 - Glazing compound fills the entire gap on both sides of the glass
- 3.19.9 CLOSE door and INSPECT squareness of door in the closed position.

CAUTION

The weight of the installed glass affects the settings of the SX panel emergency egress breakout detents and SO panel ball detents. Following installation of glass, the emergency egress breakout detents and ball detents *must* be adjusted to ensure that the door will remain tight until tune-in and final adjustment.

- 3.19.10 Refer to Sections 3.17 and 3.18, and ENSURE SX panel emergency egress breakout detents and SO panel ball detents are set tight to prevent door from swinging.

3.20 Adjusting the SX Panel Sag Following Installation of Glass

3.20.1 IF SX panel sag adjustment is required, refer to Figure 20, and **PERFORM** the following:

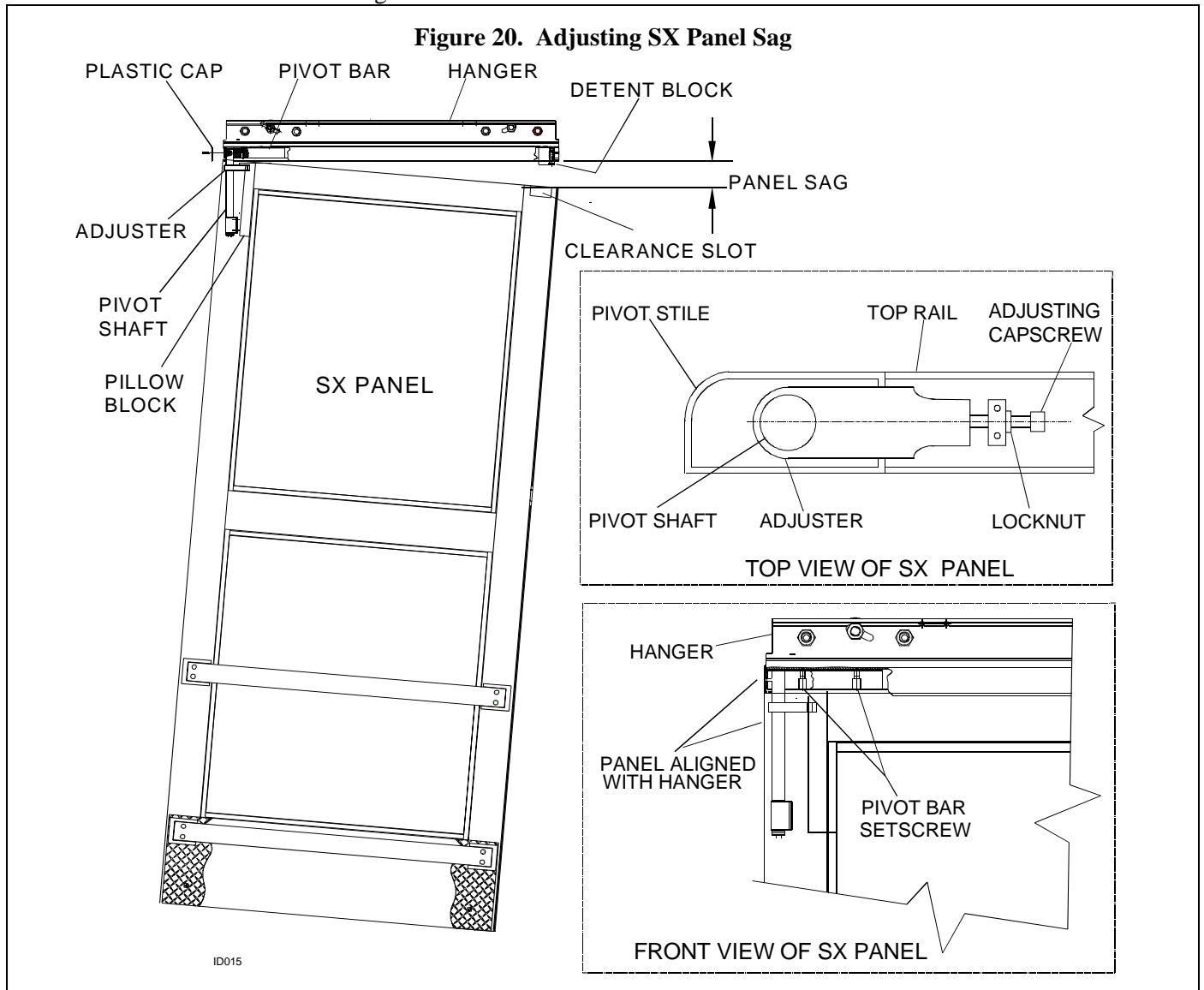

- a. SWING SX panel open approximately 10".
- b. LOOSEN screw securing end cap to detent block.
- c. LOOSEN fasteners securing detent block to hanger.
- d. LOOSEN adjusting capscrew locknut.
- e. PULL lead stile of SX panel upward, and TURN adjusting capscrew until no panel sag is observed.
- f. WHEN sag adjustment is complete, TIGHTEN adjusting capscrew locknut.
- g. ALIGN SX panel with hanger.
- h. OPEN SX panel to 90° open position.
- i. LOOSEN pivot bar setscrews.

203974
Rev. A, 8/21/01
26 of 29

- j. SLIDE pivot bar into hanger until panel and hanger are aligned, and TIGHTEN pivot bar setscrews.
- k. ALIGN detent block with clearance slot in door.
- l. TIGHTEN fasteners securing detent block to hanger.
- m. TIGHTEN screw securing end cap to detent block.

3.21 Setting the Bottom Sweep

- 3.21.1 Refer to Figure 21, and from the interior side of the door, using a pry bar SLIDE the sweep holder downward as necessary to position the bottom sweep properly.

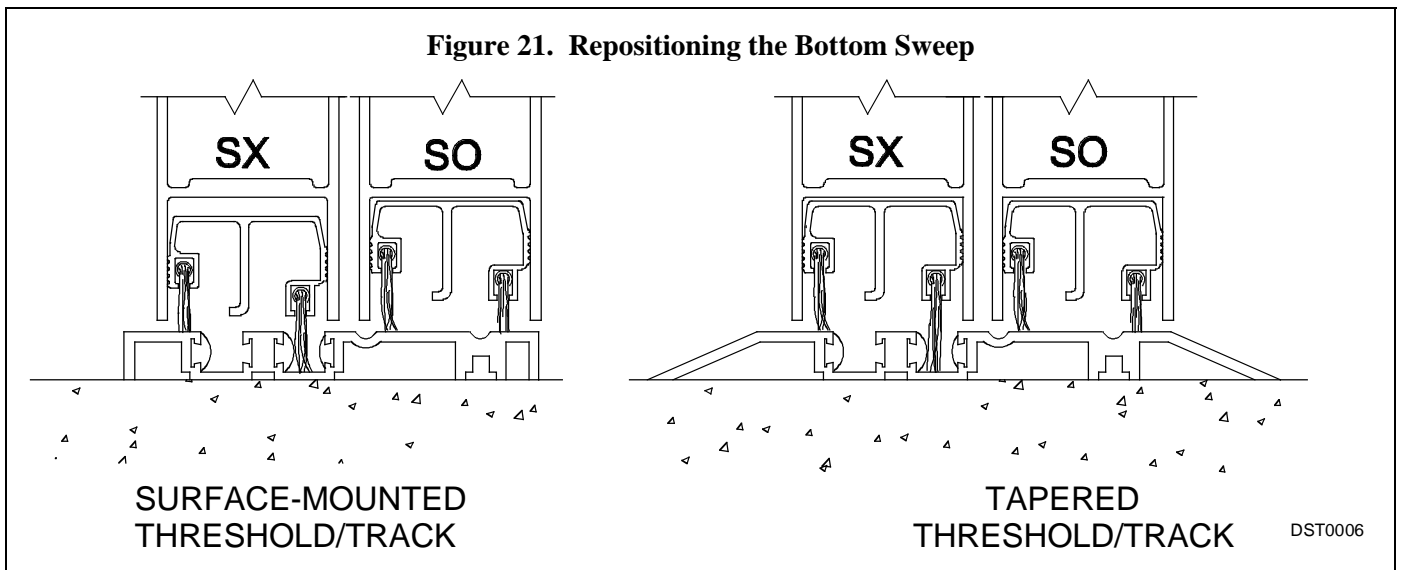

3.22 Installing the Stile Lock (2000-Series Doors Only)

CAUTION

The stile lock components are mating parts. In order for the stile lock to function properly, the door package must be aligned accurately as described in the previous sections.

3.22.1 ENSURE O and SX panel stiles are aligned properly.

3.22.2 Refer to Figure 22, and MARK the O and SX panel stiles at the following dimensions:

- 47 1/2" up from top of threshold
- 2 7/16" in from outside edge of O panel stile
- 2 5/16" in from outside edge of SX panel stile

Figure 22. Installing the Stile Lock

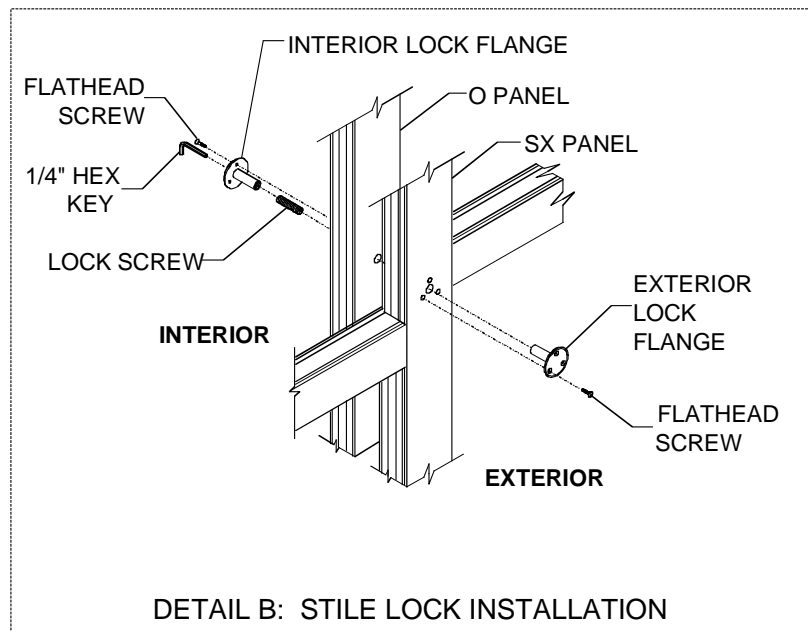
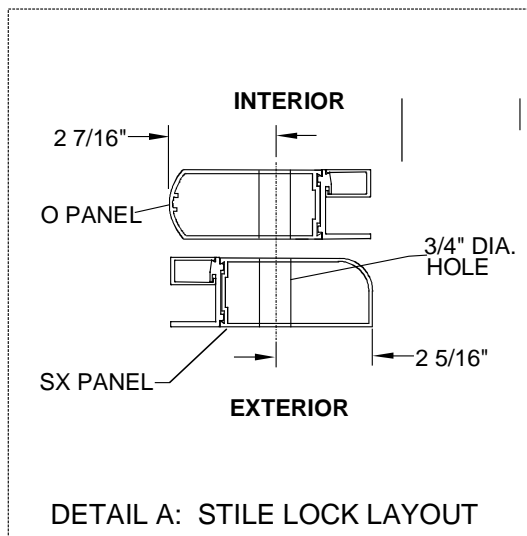
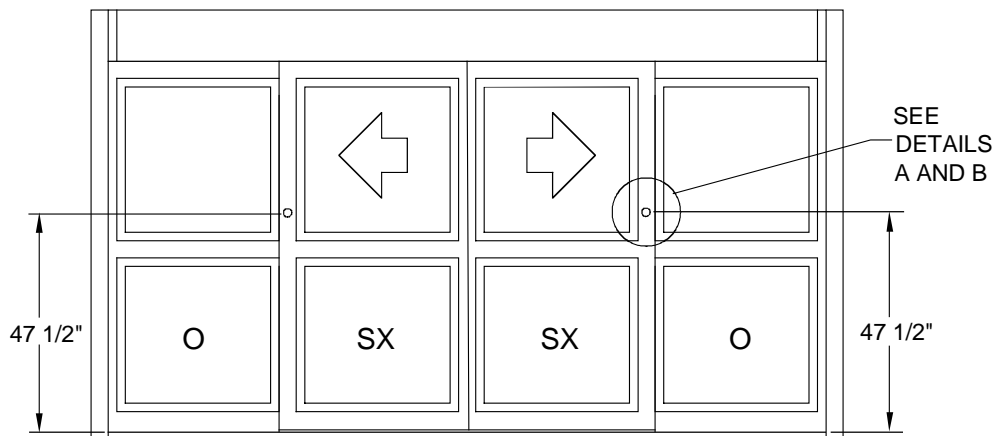

ID016

NOTE

The recommended technique for drilling the $\frac{3}{4}$ " hole in the panel stiles is to drill through both stiles at the same time. Misalignment often occurs when a $\frac{3}{4}$ " hole is drilled into the front of the SX panel and a second $\frac{3}{4}$ " hole is drilled through the back of the O panel.

- 3.22.3 DRILL a $\frac{3}{4}$ " hole through both panel stiles at the marked location, and ENSURE hole is perpendicular to the panel stile.
- 3.22.4 REMOVE burrs and sharp edges from hole on both faces of panel stiles.

NOTE

The interior and exterior lock flanges are similar with one exception: the interior lock flange has a center through hole—the exterior lock flange does not.

- 3.22.5 THREAD stile lock screw into *exterior* lock flange until the screw bottoms out.
 - 3.22.6 INSERT exterior lock flange and stile lock screw into hole in SX panel stile.
 - 3.22.7 INSERT interior lock flange into hole in O panel stile.
 - 3.22.8 TIGHTEN the interior lock flange onto the lock screw until the SX and O panels come together.
 - 3.22.9 Using the holes in the lock flanges as a guide, DRILL $\frac{1}{8}$ " holes into SX and O panel stiles.
 - 3.22.10 Using the #8-15- $\frac{1}{2}$ " flathead screws provided, FASTEN the interior and exterior lock flanges to the panel stiles.
 - 3.22.11 INSERT a $\frac{1}{4}$ " hex wrench through the center hole in the interior lock flange, and REMOVE the lock screw.
 - 3.22.12 STORE the lock screw and hex wrench in a convenient place.
- 3.23 **Installing the Safety Decals**
- 3.23.1 Refer to Document No. 203743, "Stanley Automatic Sliding Door Safety Decal Installation Guide," (supplied with door package) and INSTALL safety decals.