



TUCKER AUTO-MATION  
**SW10 (Full Power) & SW19 (Low Energy)**

**INSTALLATION GUIDE**

**Surface Mounted Applications**

**(See APPENDIX for special notes regarding installation on fire rated doors)**

**PLEASE NOTE:** NEW 35mm SPINDLE FOR PUSH APPLICATIONS REQUIRES DIFFERENT  
HEADER MOUNTING HEIGHT

## IMPORTANT

READ THIS SECTION BEFORE PROCEEDING WITH INSTALLATION



Tucker Auto-Mation, LLC (hereafter referred to as "Tucker") recommends that all of its automated pedestrian door products be installed by a trained automatic door technician and that the resulting performance of the product be in full compliance with the most current version of the American National Standards Institute document A156.10 or A156.19 (whichever is applicable) as well as any applicable building codes and/or fire codes. Tucker further recommends that a full inspection of the operating system be performed in accordance with the guidelines of the American Association of Automatic Door manufacturers (AAADM). This inspection must be performed by a certified AAADM trained inspector. Tucker recommends this documented inspection be performed upon completion of the installation as well as, following the completion of every service call thereafter. If service is not performed within one year of the previous service action, a routine AAADM inspection should be performed and documented. Under no circumstance should the product operate for more than one year without an AAADM inspection. Tucker does NOT recommend installation or service, on any of their automated pedestrian door products, by any individual who is not certified as an AAADM inspector.

Following the installation or service of any Tucker automated pedestrian door product, if it is deemed unsafe, or is operating in an unsatisfactory manner according to national performance standards or recommended performance guidelines as defined by Tucker, repairs should be made immediately. If an immediate repair cannot be made, the product should be disabled, and appropriate measures should be taken to secure the door in a safe position or to enable the door to safely be used manually. During this situation, every effort should be made to notify the owner (or person responsible) of the condition and to advise on corrective actions that must be taken to return the product to safe operation.

### LOW ENERGY APPLICATION NOTE

When using the SW10/19 for a low energy application, Tucker Auto-Mation recommends the use of a door-mounted presence sensor on the approach side of the door to be used as a secondary activation device. This type of sensor can be installed at time of installation or can also be retrofitted. This device serves to re-activate the door to the open position should a person enter into the closing path at the approach side of the door, as it is closing. Once the door is fully closed, a "knowing act" device must then be used for initial activation. Tucker Auto-Mation considers this device to be essential in reducing the possibility of doors "timing out" and closing before all pedestrians have passed through the doorway. Check with your Tucker sales representative to find out about special incentives that may be available for the Torpedo 1 door-mounted presence sensor.

**TABLE OF CONTENTS:**

Page	Contents
IMPORTANT	READ IMPORTANT NOTICE ABOVE BEFORE BEGINNING THE INSTALLATION OF THIS PRODUCT
2	Important Notices
4	Product Description & Specifications
5	STEP 1: Header Installation
6-7	STEP 2: Mounting The Operator & Control Assembly
8-9	STEP 3: Install The Arm Assembly - Standard Applications
10-14	STEP 4: OPTIONAL - Push Arm Installation With Increased Spring Tension
15	STEP 5: OPTIONAL - Pull Arm Installation With Increased Spring Tension
16-17	STEP 6: Adjusting The Mechanical Stops
18-20	STEP 7: Setting The Dip Switches
21	STEP 8: Wiring Connections
22	STEP 9: Adjusting The Control
23	STEP 10: 120 Volt AC Connection
24-27	STEP 11: Power On & Tune-In
28	Troubleshooting
28	Job Documentation & Closeout
29	Company Contact
30-31	Appendix - Adjusting The Chain Tensioner
31-38	Appendix - Wiring Diagrams
39	Appendix - Lock Relay Function
40-41	Appendix - Fire rated Door Application
42	Appendix - Tucker Logo Placement

## PRODUCT DESCRIPTION & SPECIFICATIONS

The Tucker Auto-Mation SW10 & drives. The unique design offers; non-including sensors, push plates, fire alarm, and electric locks. Troubleshooting when needed. Both units can be configured concealed application. The Tucker Advanced Programmer (TAP) is provided as an option to access additional programming features.

Power Supply	115 VAC (+6%, -10%) 60Hz										
Power Consumption	100W										
Current Consumption	1A										
Motor	24 VDC Permanent Magnet With Belt Driven Encoder										
Header Dimensions	20 3/4" x 4 1/8" x 4 3/4" (l x w x d)										
Fused Protection	3.5A Fuse (F1 located on I/O Board)										
Weight	22 lbs Per Operator Assembly										
Ambient Operating Temperature	-4 to 131° F										
Ingress Protection	IP23 (protection from spray water up to 60° from the vertical – ie. Rainstorm)										
Maximum Door Weight	<table border="0"> <tr> <td>PUSH ARM</td> <td>PULL ARM</td> </tr> <tr> <td>36" Door: 438 lbs</td> <td>342 lbs</td> </tr> <tr> <td>42" Door: 328 lbs</td> <td>256 lbs</td> </tr> <tr> <td>44" Door: 299 lbs</td> <td>234 lbs</td> </tr> <tr> <td>48" Door: 254 lbs</td> <td>198 lbs</td> </tr> </table>	PUSH ARM	PULL ARM	36" Door: 438 lbs	342 lbs	42" Door: 328 lbs	256 lbs	44" Door: 299 lbs	234 lbs	48" Door: 254 lbs	198 lbs
PUSH ARM	PULL ARM										
36" Door: 438 lbs	342 lbs										
42" Door: 328 lbs	256 lbs										
44" Door: 299 lbs	234 lbs										
48" Door: 254 lbs	198 lbs										
24 VDC Accessories Power Supply	24 VDC / 500 mA max.										
24 VDC Electric Lock Power Supply	24 VDC / 500 mA max.										
Adjustable Speeds & Timers	Opening Speed Closing Speed Hold Open Time										
Standard Selector Switch Functions	Automatic Hold Open Manual (Off)										
Standard Control Outputs	Malfunction Alarm Signal Electric Lock Power Supply 24 VDC Accessories Power Supply Door Status										
Standard Control Inputs	Interior Activation Exterior Activation Emergency Shutdown Alarm Output "Stop" Safety Device (door-mounted)										
Quick Disconnects	TAP-Controller (optional)										

## STEP 1: HEADER INSTALLATION

**Mount the back-plate to the top door frame using appropriate fasteners for the type of frame.**

- Push side mounting: Back-plate is flush with bottom of door frame.
- Pull side mounting: Back-Plate is mounted 1.5" up from bottom door frame.
- Back-plate should overlap each jamb tube by 1.5" – to aide in installation, there is an index line scribed into the back-plate at 1.5" in from the edge. Align this mark with the inside face of the jamb tube.
- **Refer to the APPENDIX for fire rated door applications.**

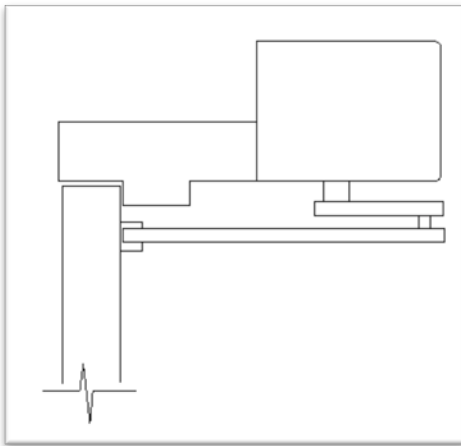

**PUSH ARM APPLICATIONS:**

Bottom of header is flush with bottom of top frame.

**NOTE:**

Tucker Auto-Mation is now using a 35mm spindle adaptor for all standard push arm applications – this requires that the header assembly be mounted as shown at left, flush with bottom of top frame.

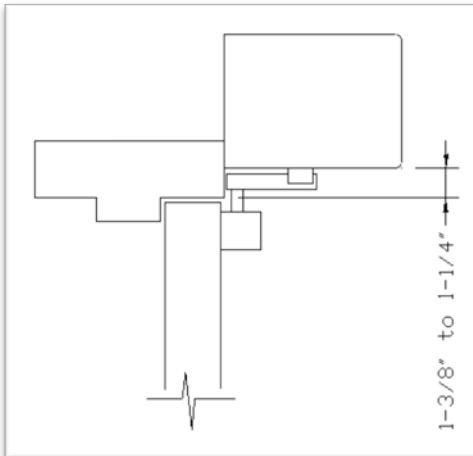

**PULL ARM APPLICATION: STANDARD PULL ARM & DOUBLE EGRESS APPLICATIONS**

Double egress applications require the use of an 80mm spindle adaptor for the side using the push arm.

## STEP 2: MOUNT THE OPERATOR(S)

- One operator works for any hand of door.
- The hand depends on how the operator is mounted to the header.
- **Refer to the APPENDIX for fire-rated door applications.**
- Determine the hand of the door to be automated and mount the operator & short back-plate assembly using the **6 screws provided**.

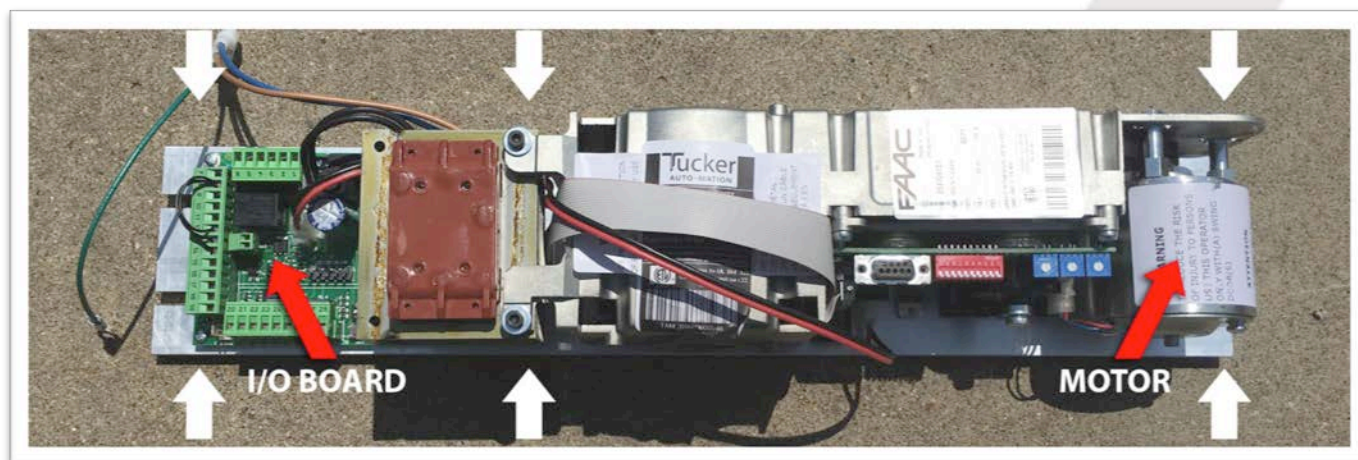

I/O BOARD IS TOWARDS HINGE JAMB

MOTOR TOWARDS HINGE JAMB

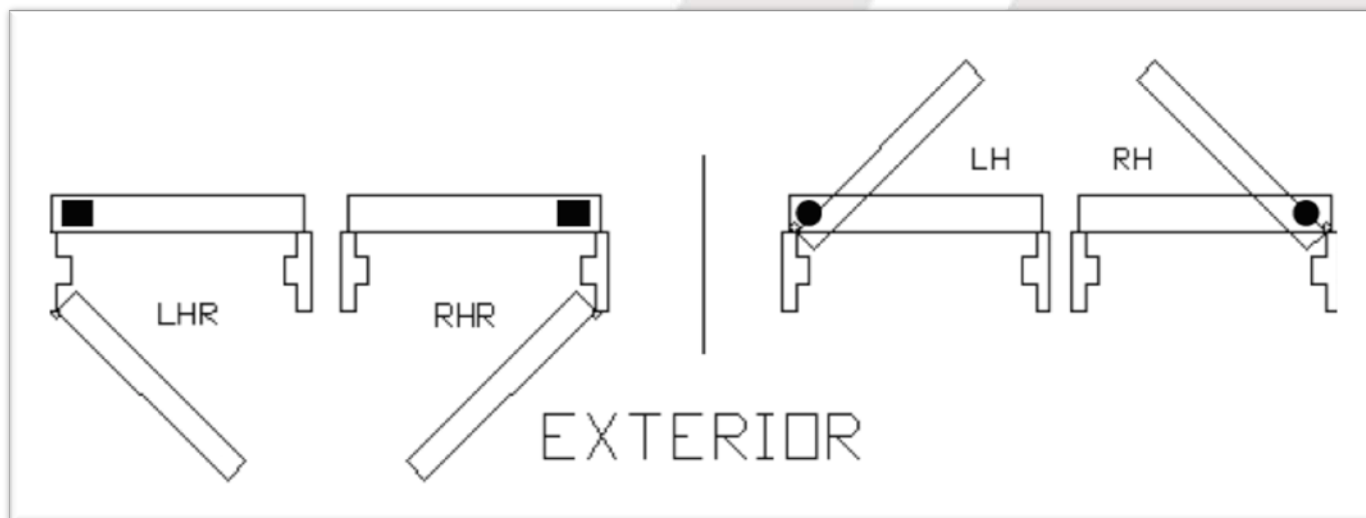

- Mount the header to the doorframe with the screws provided.
- The header will overlap the doorframe by 1-1/2" at each side.

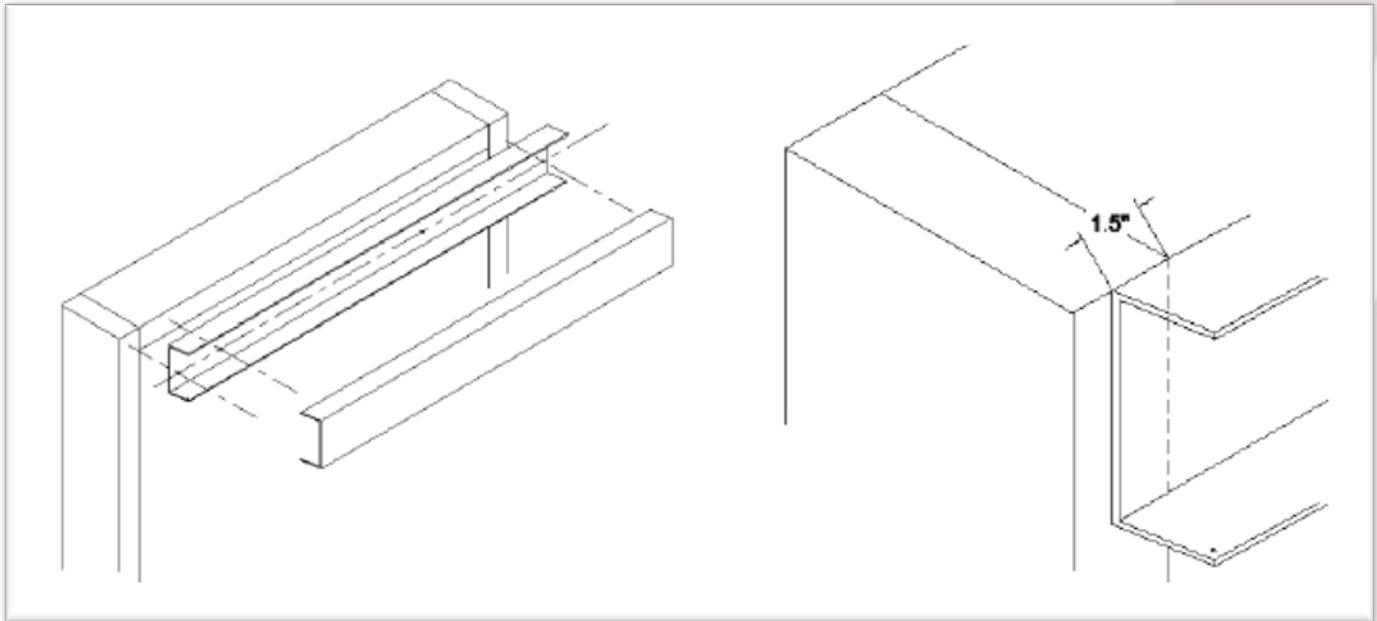

**STEP 3: INSTALL THE ARM ASSEMBLY - STANDARD APPLICATION**

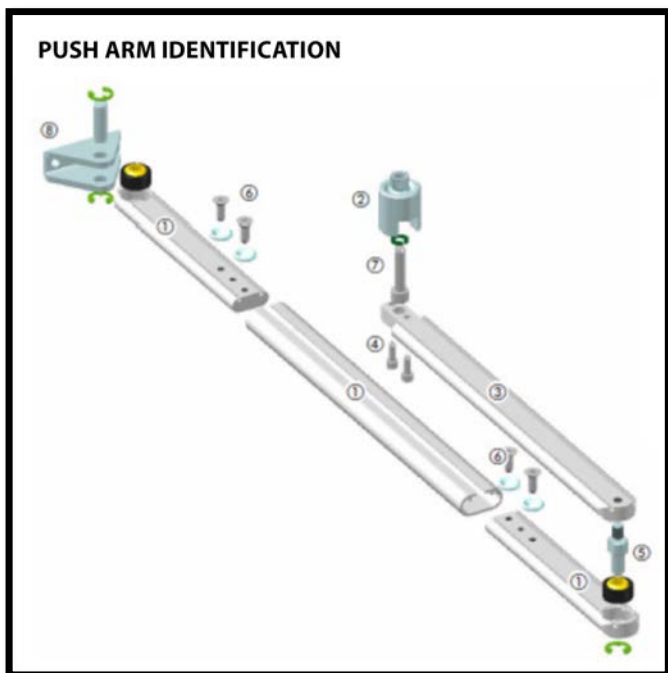

**PUSH ARM ASSEMBLY:**

1. Secondary Arm With Sleeve
2. Spindle Adaptor
3. Primary Arm
4. Spindle/Arm Attachment Screw
5. Pivot Stud
6. Secondary Arm Attachment Screws With Dimple Washers
7. Spindle Adaptor Bolt
8. Door Shoe

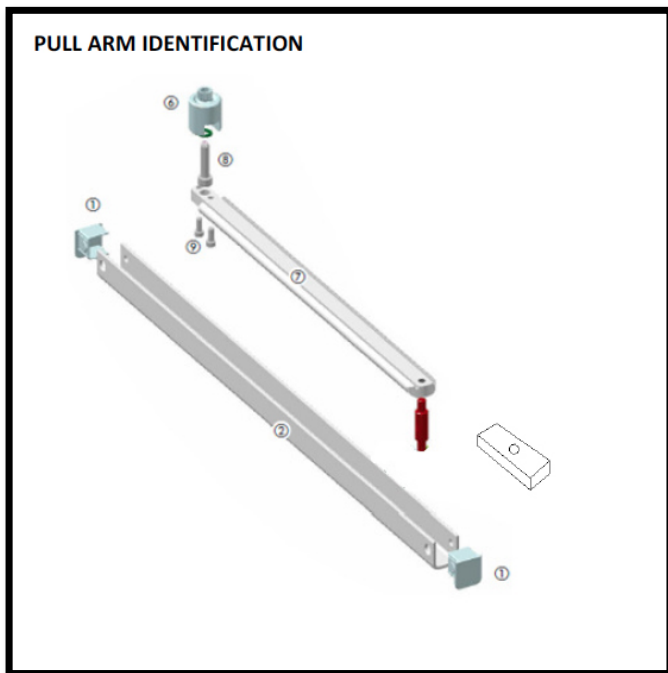
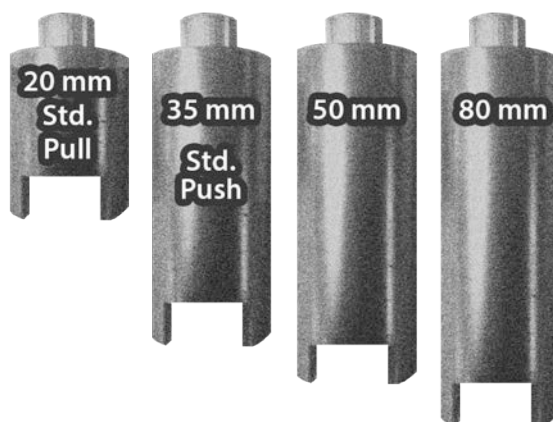

**PULL ARM ASSEMBLY:**

1. End caps
2. Slide Track
3. Slide Block Sub-Assembly
4. Slide Blocks
5. Slide Block Separator
6. Slide Block Stud
7. Primary Arm
8. Spindle adaptor Bolt
9. Spindle Adaptor/Arm Attachment



### STEP 3: INSTALL THE ARM ASSEMBLY - STANDARD APPLICATION

Follow the instructions listed below for a standard arm application using a "push" or a "pull" arm assembly. If using a push arm, AND extra door closing force is require, follow the instructions on page 7 for "Optional - Push Arm Installation With Increased Spring Tension"

#### PUSH ARM APPLICATION

Ensure the main power supply is removed or shut off at the control.

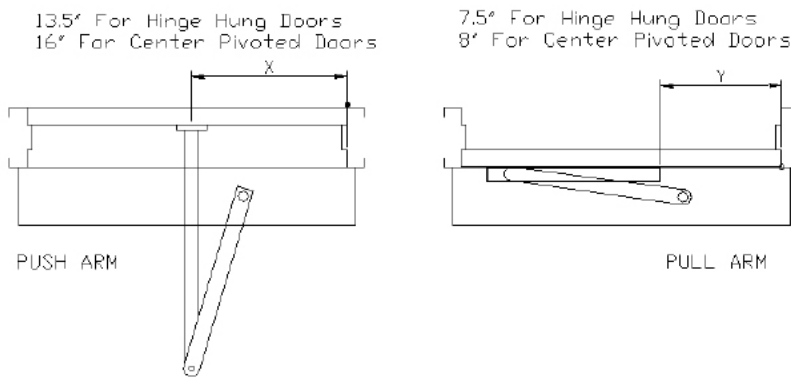

HINGE HUNG DOORS		CENTER PIVOTED DOORS	
PUSH APPLICATION	C/L of Hinge to C/L of Arm Mount Bracket	Inside face of pivot jamb to Spindle	Inside face of hinge jamb to C/L of Arm Mount Bracket
	13.5"	10.5"	16"
PULL APPLICATION	Inside face of jamb to Back Edge of Slide Track	Inside face of pivot jamb to Spindle	Inside face of hinge jamb to Back Edge of Slide Track
	7.5"	10.5"	8"

#### PULL ARM APPLICATION:

- Includes double egress applications.
- Ensure the main power supply is removed or shut off at the control.
- Install the slide track assembly to the door at the specified location.
- Attach the track with the screws provided.
- Install the primary door arm and spindle onto the operator so that the arm is approximately 30 to 45 degrees past the door closed position.
- Once the arm is installed and tightened, pull the arm towards the opening direction and insert the drive block into the track assembly.

- Manually move the door from the full closed position to the full open position to make sure there is enough travel from the operator.
- If more travel is required, adjustment of the mechanical stops on the operator may be required.
- See the next section for adjustment if needed.

## STEP 4: OPTIONAL - PUSH ARM INSTALLATION WITH INCREASED SPRING TENSION

- Prior to beginning the push arm installation, gather the following information about the application:
  - Door configuration
  - Reveal distance (inches)
- Use the chart below to determine the prescribed length of the secondary arm assembly and note the dimensions.

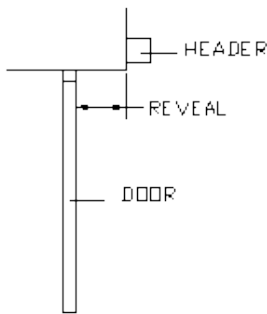

Reveal	Hinge Hung X Dim.	Center Pivot X Dim.
0"	13"	16"
1"	14"	17"
2"	15"	18"
3"	16"	19"
4"	17"	20"
5"	18"	21"
6"	19"	
7"	20"	
8"	21"	
DEEPER REVEAL REQUIRES ARM EXTENSION		

- Before installing any portion of the door arm assembly, it is easiest to lay the arm out on a flat surface and insert the secondary and primary arm into the sleeve as it will be when installed on the door:
  - Slide the short arms within the sleeve to obtain the prescribed "X" dimension.
  - Tighten the screws on the short arm that is connected to the door shoe.
  - Double-check the "X" dimension of the arm - this is the distance between the center of the hole at the door shoe and the center of the hole at the pivot point of the primary arm (as shown).
  - Mark a pencil line at the edge of the sleeve where it overlaps the short arm that is connected to the primary arm. This will make it easier when positioning the primary arm for final installation.

PUSH ARM

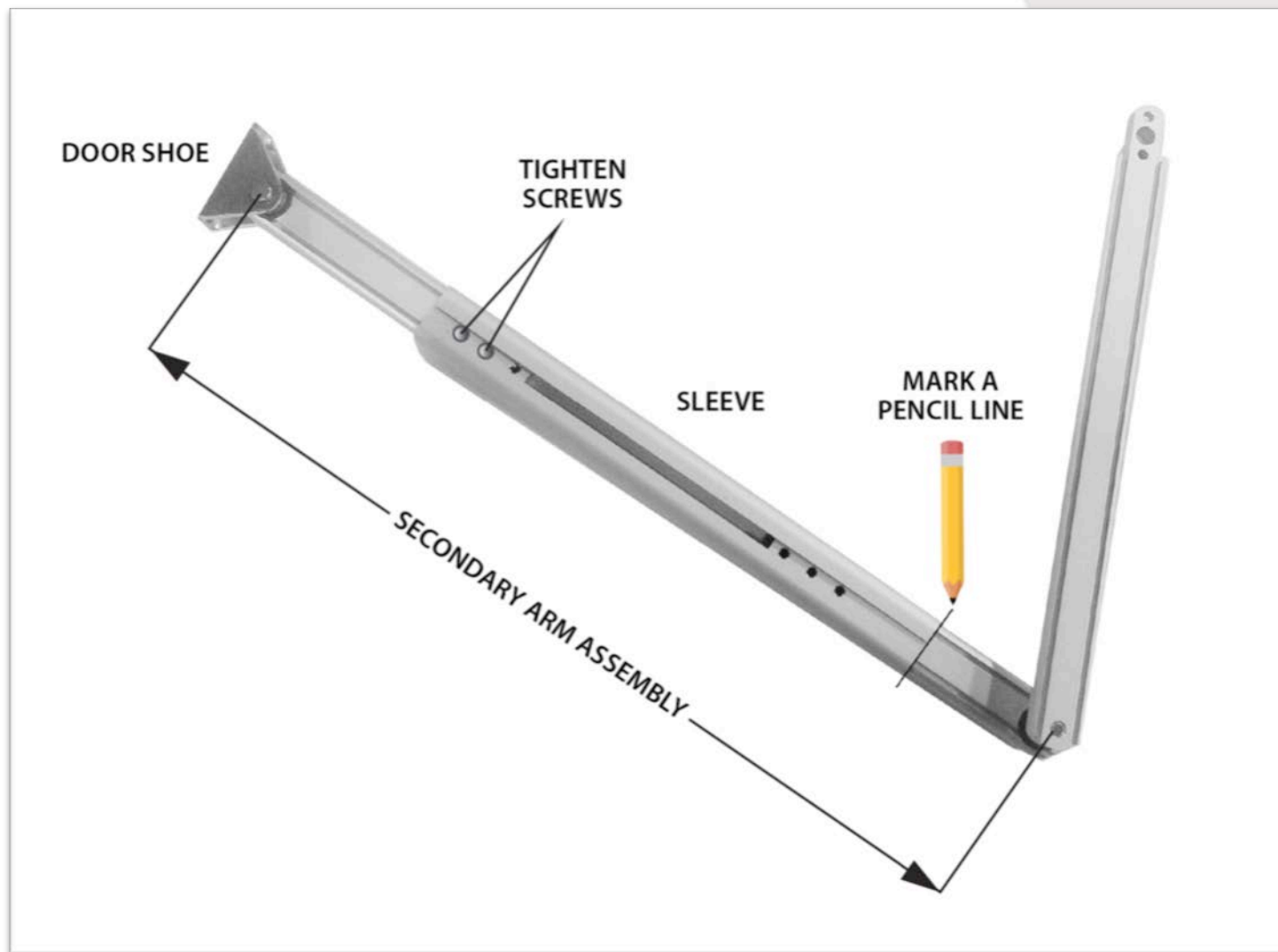

## STEP 4 Cont.: OPTIONAL - PUSH ARM INSTALLATION WITH INCREASED SPRING TENSION

- The door shoe and short arm comes pre-assembled - it is not necessary to take the assembly apart.
- Install the door shoe per the door hinge / pivot configuration - see below:
  - Hinge Hung Doors: Centerline of door shoe at 13.5" in from inside of hinge jamb
  - Center Pivot Doors: Centerline of door shoe at 16" in from inside of pivot jamb
  - The horizontal centerline of the door shoe will be at 2" below the bottom of the back-plate
  - Do NOT install the primary arm until instructed to do so

HINGE HUNG

CENTER PIVOTED

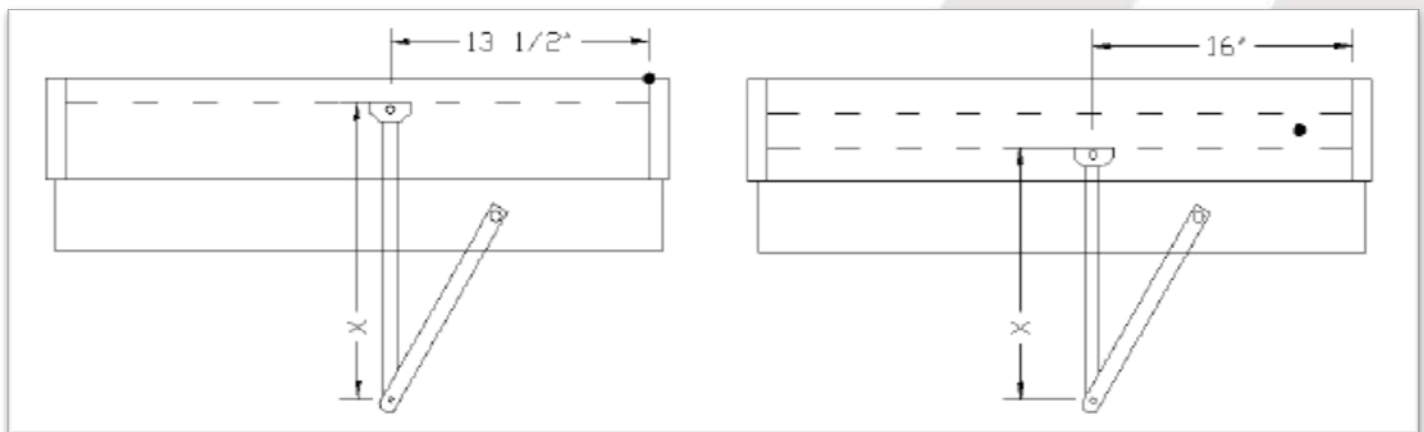

- Ensure the mechanical door stops are at their maximum position as shown.

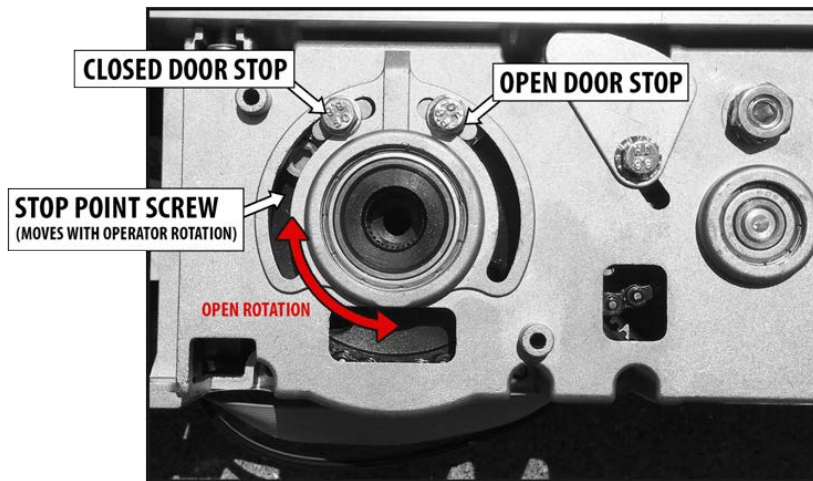

- Apply 120 VAC Main power to the control
  - Place the On-Off-Hold switch to the Hold Open position

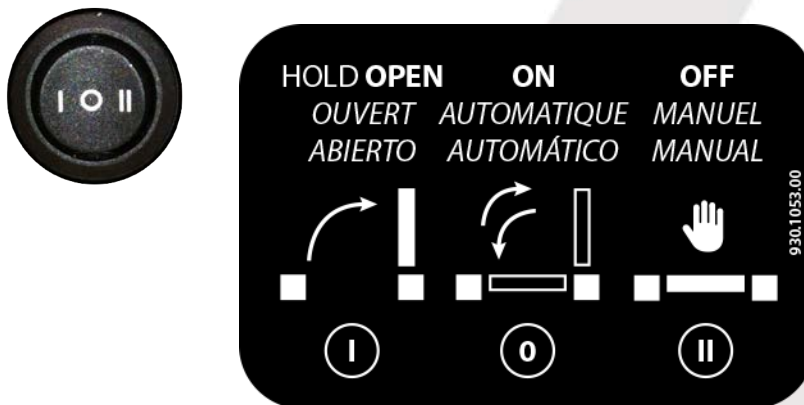

## STEP 4 Cont.: OPTIONAL - PUSH ARM INSTALLATION WITH INCREASED SPRING TENSION

- Observe the Stop Point Screw on the operator as it is opening and ensure that it rotates to the full open position against the open door stop - leave the switch in the Hold Open position
- Manually move the door panel to the 90 degree open position
- Insert the primary door arm spindle and adaptor at a position that is as close as possible to allow alignment of the pencil line within the arm sleeve
- Tighten the spindle adaptor to the operator
- Slide the arm within the sleeve to finely adjust the exact full open door position - tighten the Allen-head screws within the sleeve once complete
- Place switch to the Off position and allow the door to close
- When closed, the secondary arm should be at approximately 90 degrees to the face of the door as shown - it is not imperative that the arm be at this "exact" position
- If the primary arm is re-positioned in the operator by a tooth or two, the resulting arm position when closed will look more like what is shown - this will also result in a lower push force at the door.
- Upon final installation of door arm assembly, press SW1 to launch a new setup - this is required for the control to learn the new door stroke. Refer to Step 9, Power On & Tune In Section if further instruction for setup is required.
- Upon successful completion of setup, proceed with remainder of installation.

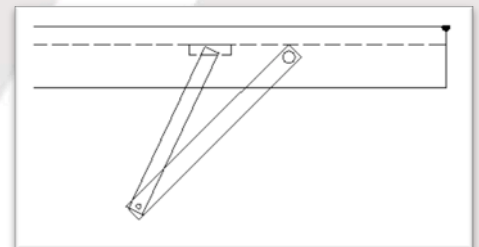
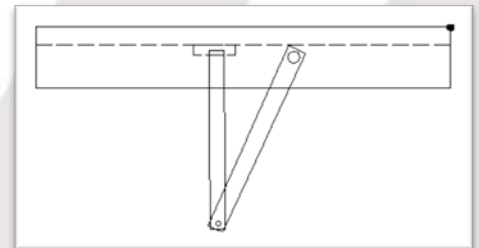

## STEP 5: OPTIONAL - PULL ARM INSTALLATION WITH INCREASED SPRING TENSION

- Apply 120 VAC Main power to the control
  - Place the On-Off-Hold switch to the Hold Open position

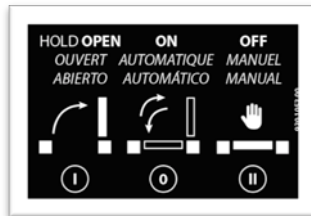

- Observe the Stop Point Screw on the operator as it is opening and ensure that it rotates to the full open position against the open door stop - leave the switch in the Hold Open position
- Manually move the door panel to the 90 degree open position
- The pull arm assembly is a fixed dimension and is not adjustable in length
- Install the arm and spindle adaptor to each other (7,8,9) and insert it into the operator at a position that allows the slide block to go in the door-mounted slide track. If it does not align exactly, install the arm so that it is past the open door. Once it is in place, tighten the main adaptor bolt to secure the arm to the operator.
- If the arm alignment was not exact, perform the following:
  - Place the On-Off-Hold switch to the OFF position and allow the door to close.
  - Loosen the "open door" mechanical stop on the operator.
  - Manually move the door to the desired full open position.
  - Slide the open door mechanical stop to meet the stop point screw - refer to the next section if additional instruction is required.
  - Tighten the stop and double check the actual open door position.
- Place the On-Off-Hold switch to the ON position.
- Press and hold button SW1 to launch a new setup

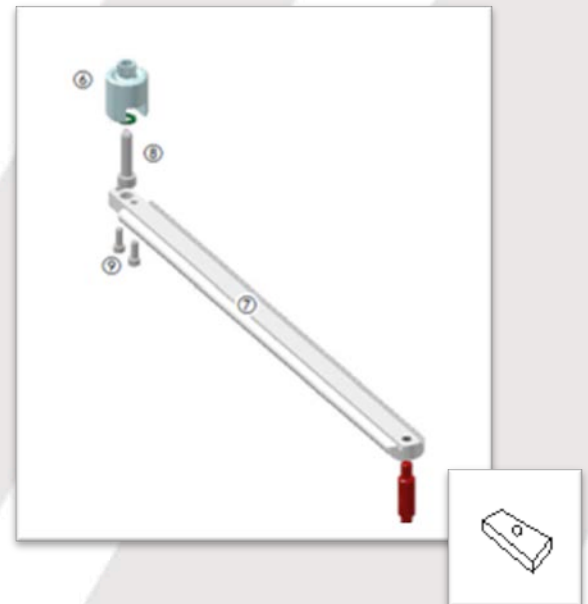

## STEP 6: ADJUSTING THE MECHANICAL STOPS

- **CAUTION – DO NOT REMOVE THE STOPS**
- **IMPORTANT - This step may be optional depending on your application**
- The mechanical stops are located on the top or bottom of the operator, depending on the hand of the door.

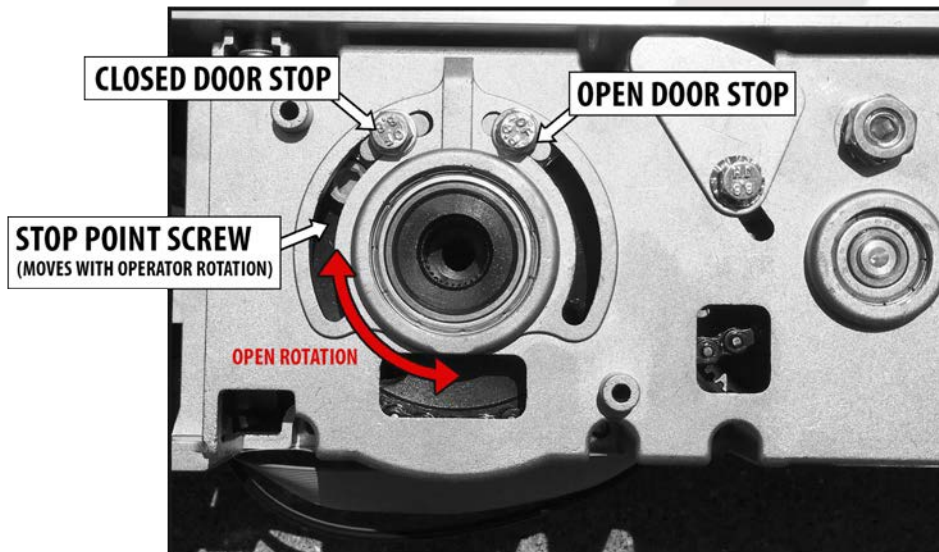

- The opening direction is always counter-clockwise rotation when viewed as shown above
- Loosen the bolts on the desired stop (do not remove bolts) and move to the desired position
- Re-tighten bolts securely and test the door travel stroke





## IMPORTANT OPTION

- If the door closes against a fixed door stop that is door frame mounted, the **CLOSED STOP** does **NOT** have to be adjusted to meet the stop-point screw. The step is then optional.
- The open door stop setting is optional. A "**SOFT STOP**" is sometimes preferred depending upon the application, particularly if heavy manual use is anticipated. The Soft Stop is simply a method of programming the door for the open position by means of a temporary stop method; such as holding your foot at the desired location during programming. To use the Soft Stop method, perform the following:
  - Press the automatic setup button (SW1 - as shown on page 14), to allow the start of the setup process
  - Position your foot on the ground at the desired full open door position. Allow the door to open and hit your foot during the first opening cycle during setup - you can then remove your foot from that position.
  - Allow the setup to complete itself thereafter
  - The door will open automatically thereafter to that position. When the door is pushed further than the soft stop location it will return to the programmed point automatically.
  - Do not use the soft stop method if there is anything behind the open door that the door could be repeatedly pushed into from manual openings - such as a glass wall.

## STEP 7: SET THE DIP SWITCHES ON THE I/O BOARD

- Set the dip switches according to the application.
- Dip switches are used to apply specific functions to the control.
- There are 2 sets of dip switches. A 2-position on the I/O board (DS2), and a 10-position at the adjustment board (DS10).

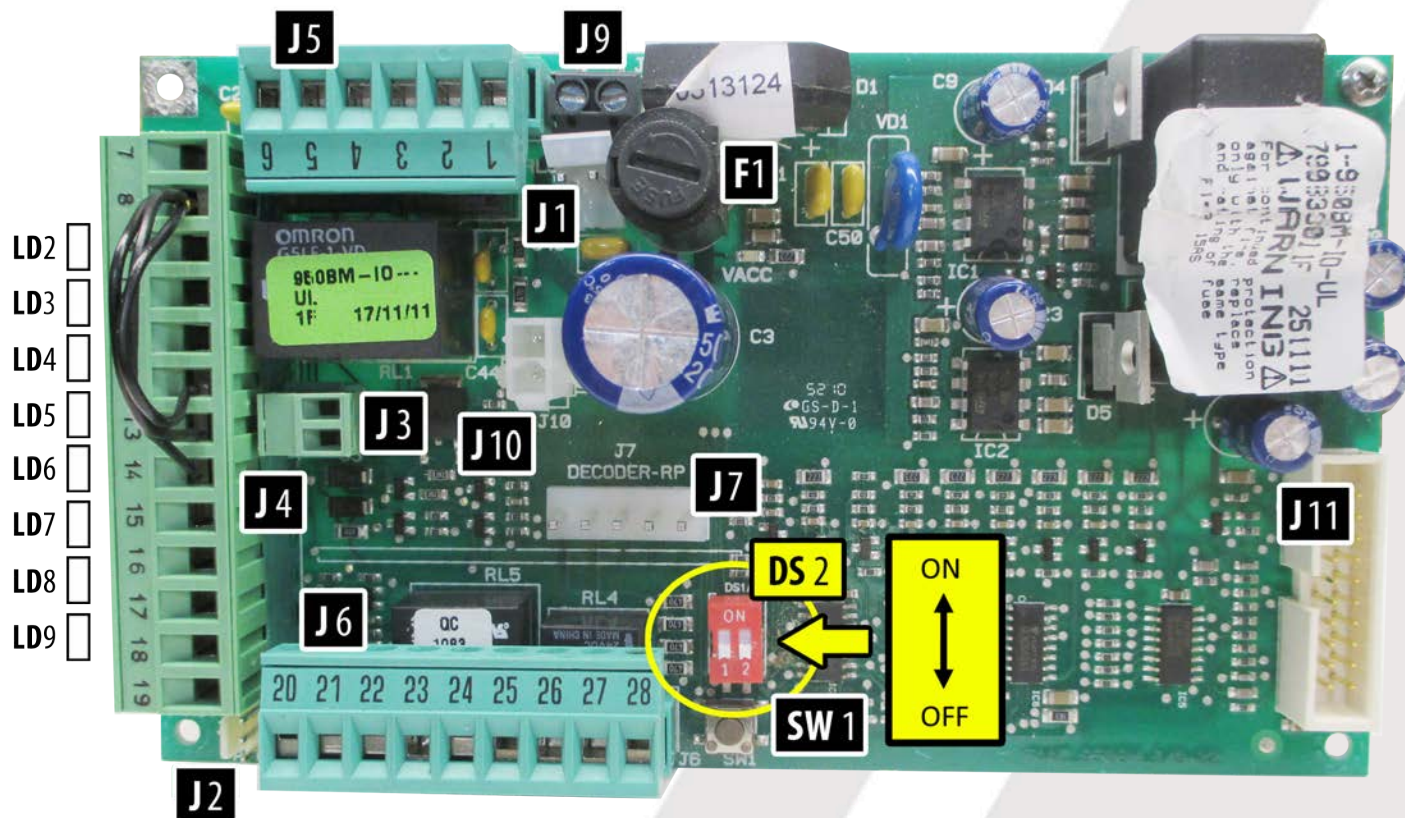

		Description	ON	OFF
DS2	1	Push-N-Go Hold Time	The hold time is set by TR3 potentiometer at adjustment board	3 Seconds (Default)
	2	Electric Lock Delay	500 milliseconds	200 milliseconds (Default)

## STEP 7 Cont. : SET THE DIP SWITCHES ON THE ADJUSTMENT BOARD

- Set the **dip switches** according to the application.

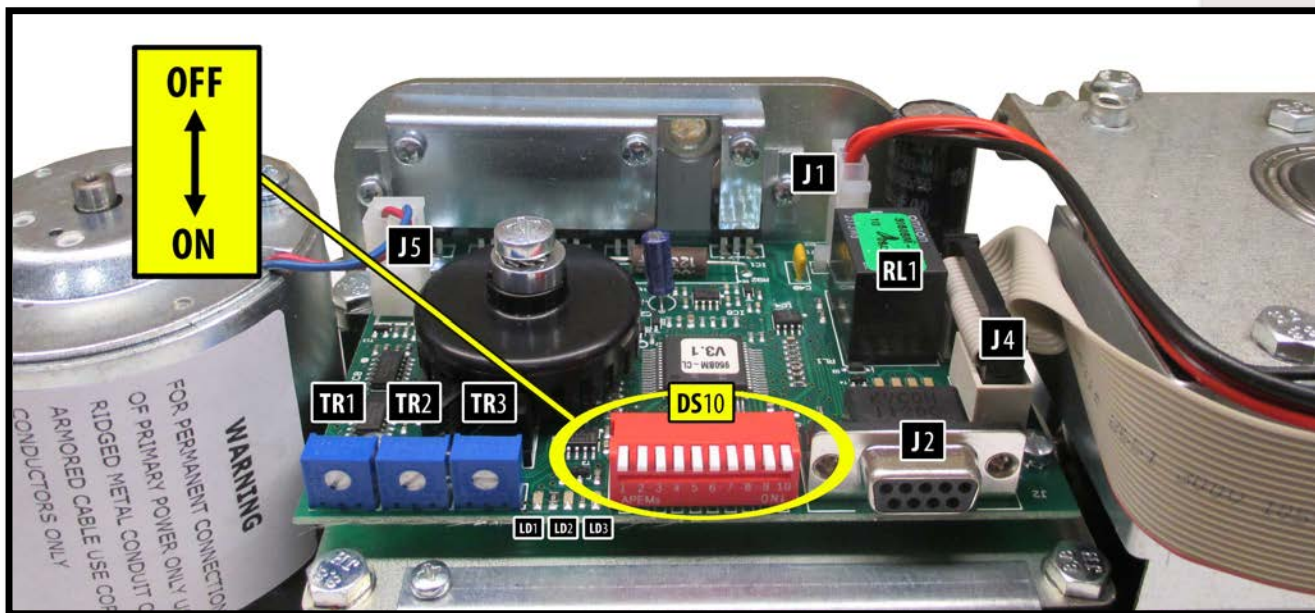

	Description	ON	OFF
1	Closed Door Force	Additional force applied while door is in closed position. Be sure to maintain ANSI compliance if using on low energy application. Cannot exceed 30 lbf to get door moving from jamb.	Disabled (Default)
2	Push / Pull Arm	Slide Arm Application. Operator stroke at 90° degrees or less. Visible change in performance may not always be noticeable.	Push Arm Application. Operator stroke 90° or greater. (Default)
3	Night Function (Exit Only)	Allows activation at input 10 when On-Off switch is in OFF (night function) position.	Disabled. The On/Off switch, when OFF, requires manual operation of the door. (Default)
4	Push and Go	Enabled	Disabled (Default)
5	<u>Full Power / Low Energy</u>	<u>Low Energy performance enabled. 5 seconds to open, 7 seconds hold open, 5 seconds to close. Speed &amp; time potentiometers are disabled. Settings are fixed.</u>	<u>Disabled. Control can be adjusted for full power or low energy operation via potentiometers. (Default)</u>
6	Lockout Function	Overhead presence sensor input (17) is inhibited during closing cycle unless input 14 is triggered. Connect COM and Input 14 to NC output of lockout safety beam.	Disabled. Overhead presence sensor input (17) is inhibited during closing cycle. Otherwise, if commanded, it keeps an open door open and a closed door closed. A command at Input 14 will stall the door. (Default).
7	Inhibit at 30 Degrees Before Door Fully Open	Input is disabled at 30 degrees prior to full open door position. Eliminates need for external inhibiting switch.	Stall function remains uninhibited for full door stroke. (Default)
8	Power Close	Additional closing force applied for final 10 degrees of closing.	Disabled (Default)
9	Assisted Manual Closing***	Enabled assisted closing following a manual opening	Disabled assisted closing following a manual opening
10	FACTORY USE ONLY		

**\*\*\* Tucker Auto-Mation recommends the use of a door-mounted secondary activation device when dip switch 9 is ON - Enabled.**

## STEP 8: WIRING CONNECTIONS (wiring diagrams are located in the Appendix)

### I/O BOARD CONNECTIONS

	Position	Function	Description
TERMINAL STRIP J5	1	Electric Lock Relay	Common
	2	Electric Lock Relay	N.O. Dry contact – Contact closes upon activation. May be used for fail-secure locks by routing 1 leg of power through the relay. Relay is triggered by activation inputs 10, 11, or 16. Relay remains energized until door is fully closed again.
	3	Electric Lock Relay	N.C. Dry Contact - Contact opens upon activation. May be used for fail-safe locks by routing 1 leg of power through the relay. Relay is triggered by activation inputs 10, 11, or 16. Relay remains energized until door is fully closed again.
	4	Door Status - Closed	N.O. Contact is closed when door is closed. The contact opens as soon as the door opens.
	5	Door Status – Common	Common contact for door status
	6	Door Status - Open	N.C. – Contact is closed when door is open. The contact opens as soon as the door starts to close. This input can be used for motor connection at lockout relay when power is looped through, thus switching power on when door is open.
TERMINAL STRIP J4	7	GND	Common GND
	8	GND	Common GND
	9	+ 24 VDC	.5A Max. Current
	10	Internal Activation	Requires N.O. Contact between input 10 & COM. Remains capable to activate when dip switch 3 is ON AND On-Off switch is OFF.
	11	External Activation	Requires N.O. Contact between input 11 & COM.
	12	Emergency Closing	Requires N.C. contact between 12 & COM. Upon open contact, door closes and overrides all other inputs. Remains jumpered if input is not used.
	13	Secondary Activation	Requires N.C. contact between 13 & COM. Disabled in full closed position.
	14	“Stall” Safety	Requires N.C. contact between 14 & COM. Upon open contact, (Dip 6 OFF) during opening, door stops, then resumes at reduced speed when input is released.
	15	Not Used	Not Used
	16	Alarm Input	N.O. contact, when closed causes door closing. All inputs inhibited during closed contact (not available on all software versions)
	17	Overhead Presence Sensor Input	Requires N.O. contact between 14 & +24 VDC (input 9). When input is closed it causes an open door to stay open and a closed door to stay closed. Works in conjunction with dip switch #6.
	18	GND	Common GND
	19	GND	Common GND
	20	Aux Relay	Auxiliary Relay NOTE: Relay is triggered by input 14
	21	Aux Relay	Auxiliary Relay N.O.
	22	Aux Relay	Auxiliary Relay N.C.
	23	Alarm Output - Common	Common
	24	Alarm Output	N.O. output is closed upon closed contact from fire alarm. LED 2 also illuminates.
	25	+ 24 VDC	.5A max.
	26	GND	Common GND
	<b>Inputs 27 &amp; 28 not used</b>		

## STEP 9: ADJUSTING THE CONTROL

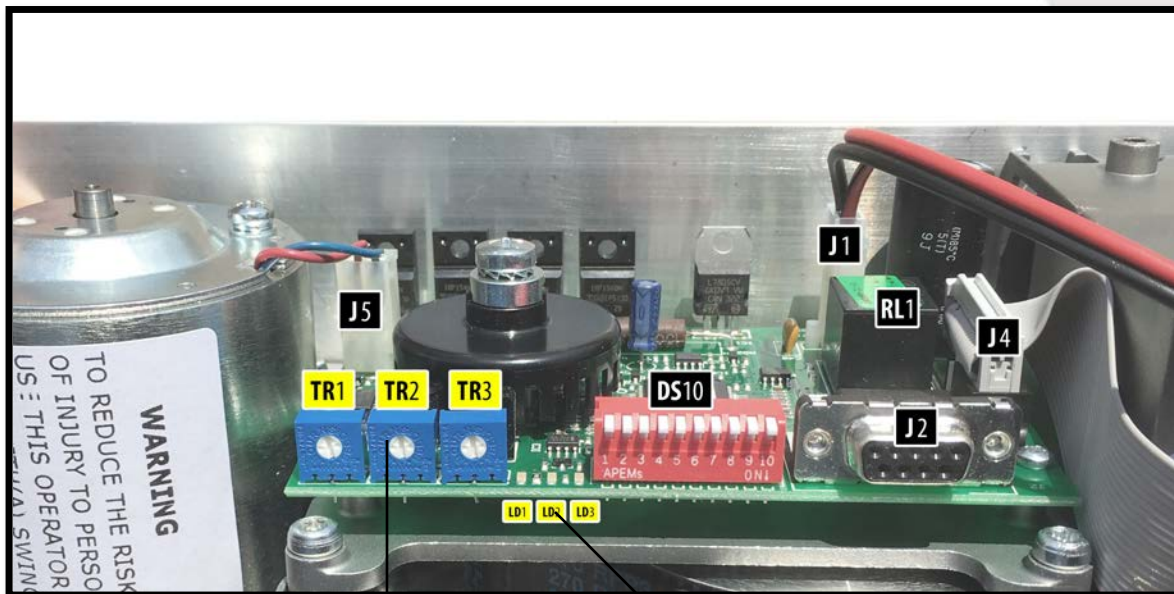

Adjustment Board Trimmers		Adjustment Board LEDs	
TR1	Opening Time Adjustment (4 - 10 secs)	LD1	GREEN LED Indicates motor power
TR2	Closing Time Adjustment (4 - 10 secs)	LD2	Rapid flashing RED indicates setup in progress
TR3	Hold Open Time (0 - 30 secs)	LD2	Slow flashing RED indicates fault
Note: Clockwise rotation increases time		LD3	GREEN LED indicates 5Vdc power supply

### HELPFUL NOTES:

- Speed and time adjustment changes will not take effect until the door closes fully after the adjustment has been made.
- Hold Open time affects the delay following activation from input 10, 11, and 13.
- Opening & closing force are a function of the automatic setup and are not adjustable.
- Check speeds and durations are a function of the automatic setup and are not adjustable.
- When Dip Switch 5 is ON, the blue speed and time potentiometers are disabled and will have no effect.

## STEP 10: 120 VOLT AC ELECTRICAL CONNECTION

### WARNING:

**Ensure all incoming electrical power is shut off before proceeding with any wiring to SW10/19. Failure to do so may result in damage to equipment or personal harm.**

- Connect the main power to the Black / White / Green connector on the back-plate.
  - Main power supply: 120 VAC, 15A, Single Phase, 60 Hz. circuit
  - Attach the incoming 120 volt AC line wires to the wiring provided in the header – as shown below.
- DO NOT TURN POWER ON until all remaining wiring has been completed.

BLACK: 115 VAC Power  
 WHITE: Neutral  
 GREEN: Ground



## STEP 11: POWER ON & TUNE-IN

- Ensure all wiring is complete according to the application
- Ensure the 120 VAC is connected and secure
- Ensure Off-On-Hold Switch is in the middle (0) position
- Apply power and observe the LED's at the control
- The control will not accept an activation until approx. 8 seconds after powering on
- The control will not initially activate the door until an activation, such as input 10, is triggered

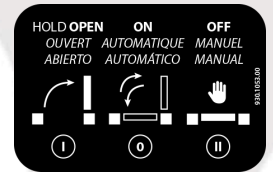

### I/O Board LED Status

LED	LED ON	LED OFF	NOTES
LD1	Accessories power is present	No accessories power	
LD2	Active internal opening command	Internal opening command inactive	Indicates status of input 10
LD3	Active external opening command	External opening command inactive	Indicates status of input 11
LD4	Emergency command inactive	Emergency command active	Indicates status of input 12
LD5	Secondary Activation inactive	Secondary Activation command active	Indicates status of input 13
LD6	Stop command inactive	Stop command active	Indicates status of input 14
LD7	In active	Inactive	Inactive
LD8	Fire Alarm command is active	Fire Alarm command inactive	Indicates status of input 16
LD9	Overhead Presence Command Active	Overhead Presence Command Inactive	Indicates status of input 17



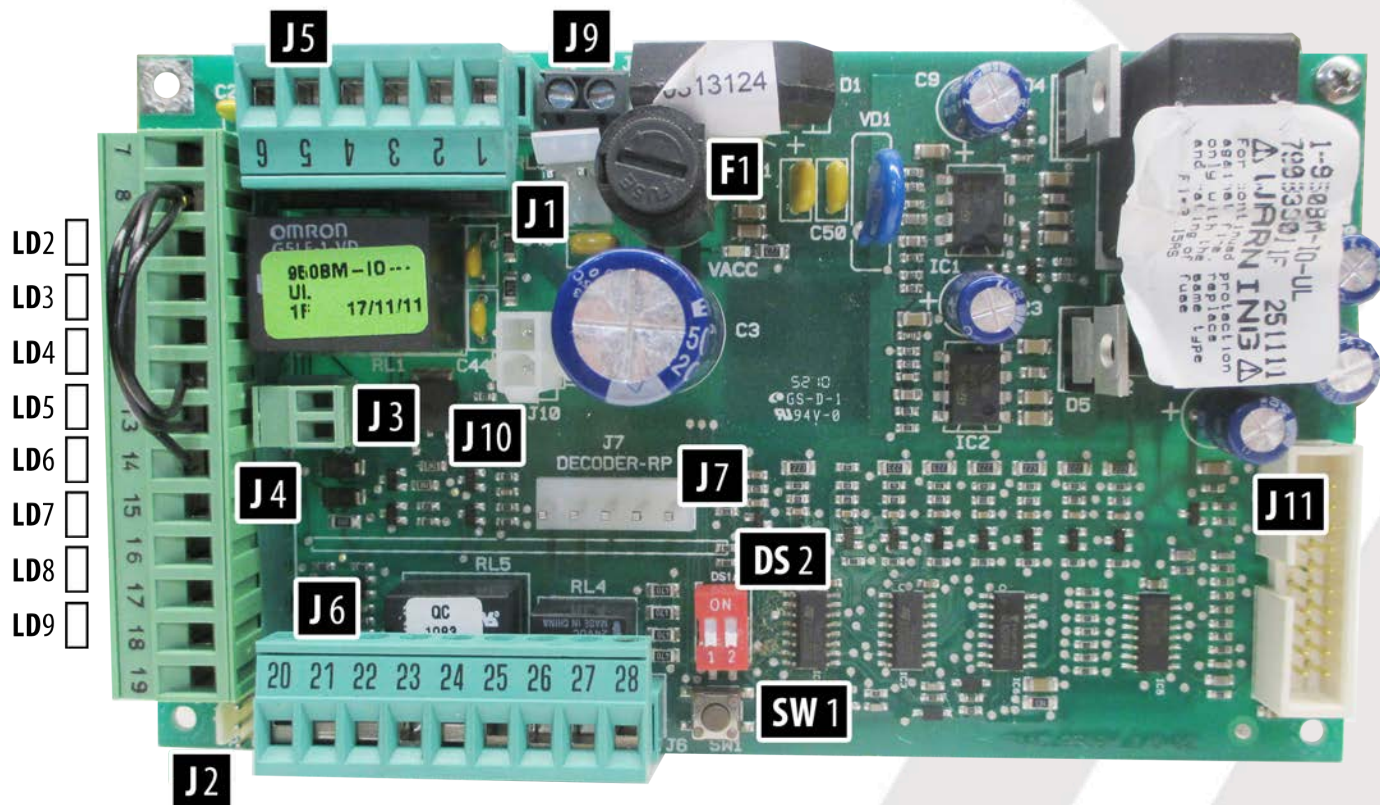

- As a general rule for **LED** observation:
  - For normally open inputs, the respective LED will illuminate upon triggering the input.
  - For normally closed inputs, the respective LED will extinguish upon triggering the input.
  - This information can be used to help quickly troubleshoot and find triggered circuits.

## STEP 11 Cont.: POWER ON & TUNE-IN

- Perform a setup at the control as follows:
  - Ensure main power is on
  - At the I/O control board, depress the SW1 button for approximately 5 seconds. When the red LED (LD2) at the Adjustment Board begins flashing rapidly, release the button.
  - Door will slowly go open, recycle partially, close and then re-open.
  - **Do not interrupt the process and do not move the door manually during this time.**
  - If the door does not open and the red LED (LD2) is flashing slowly, check to make sure the motor is plugged in properly at the control board. Correct as necessary.
  - Once the setup process is complete, the door will close and the LED will go out.
  - Setup is complete.

**IMPORTANT NOTE: If the operator stroke is altered in any way, a re-learn must be accomplished.**

- Upon completion of the Setup, activate the door to open and ensure all performance is acceptable.
- Adjust opening and closing speed as necessary. If speeds are changed, a re-learn is not required.
- A re-learn is not required following a main power recovery.
- Adjust hold-open time as required.

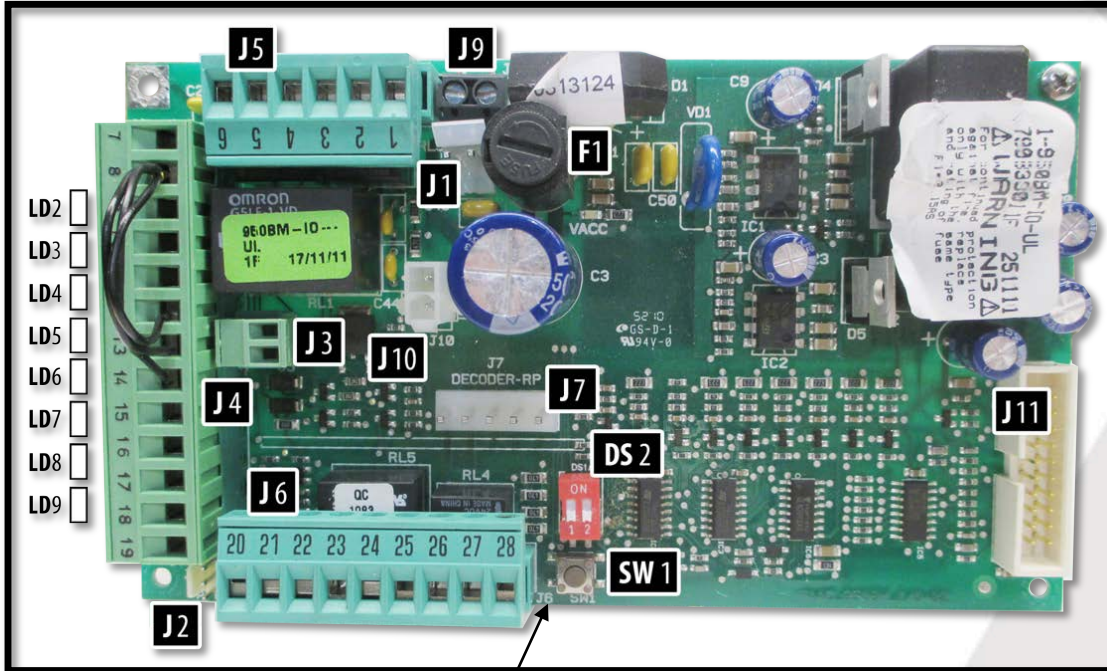

SETUP BUTTON

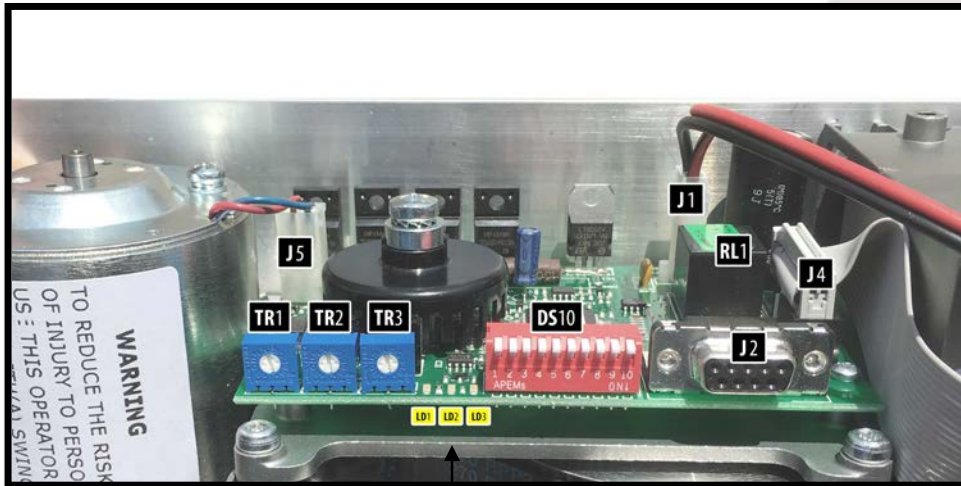

FLASHING RED LED

## TROUBLESHOOTING

Door will not open	<ul style="list-style-type: none"> <li>• Check On-Off switch for proper position</li> <li>• Check LED status for LD 5, 6, and 7. If any of these LED's are OFF, the door will not open. They require a normally closed circuit.</li> <li>• Launch a new setup – see page 26</li> <li>• Check status of emergency input 12</li> <li>• Door has traveled close past the 0 degree position</li> </ul>
Door will not close	<ul style="list-style-type: none"> <li>• Check status of LEDs" LD2, 3, 4, 8 on the I/O board.</li> <li>• If any of the LED's are ON, check the associated input</li> </ul>
Door will not reach its full open or closed position	<ul style="list-style-type: none"> <li>• Check the mechanical stops on the operator for proper adjustment <b>(see page 16)</b></li> </ul>
Slow flashing red LED (LD2) at the Adjustment Control Board	<ul style="list-style-type: none"> <li>• Indicates a possible fault in the control.                             <ul style="list-style-type: none"> <li>○ Check LED status for the other inputs. This will identify if any inputs are currently active.</li> </ul> </li> <li>• Indicates a potential faulty setup.                             <ul style="list-style-type: none"> <li>○ Loose or incorrect motor connection</li> <li>○ Possible loose chain tensioner - refer to Appendix for chain tensioner adjustment procedures.</li> <li>○ Launch a new setup. If problem repeats and there are no other discrepancies noted, replace the operator/control sub-assembly.</li> </ul> </li> </ul>
Door closes too fast at last 5 to 10 degrees of closing	<ul style="list-style-type: none"> <li>• Ensure dip switch 8 is OFF.</li> <li>• Ensure there is no binding of the door as it is closing through the last few degrees of closing. If binding exists (from a tight bottom sweep, for example), correct the condition and then re-launch a new setup.</li> </ul>

## JOB DOCUMENTATION & CLOSEOUT

- Upon completion of the installation, provide the following to the Owner or their assigned agent:
  - Completed & signed work ticket. Be certain to record any serial numbers for items that were replaced.
  - Completed and signed copy of the AAADM inspection form
  - AAADM Owner's Manual
- Additionally, advise the Owner of the work that was performed and ask if there are any other doors that may require service.

## **ACCESSORIES**

- Tucker BAT Microwave Motion Sensor - PN: 200.1068
- Tucker TORPEDO ONE door-mounted presence sensor - PN: 200.1087
- Spindle Adaptors 20, 50, 80 mm

## **COMPANY CONTACT**

- ***Tucker Auto-Mation, 1081 3<sup>rd</sup> Street, North Versailles, PA 15137***
- ***Tel. 1-855-8 TUCKER (1-855-888-2537)***
- ***[www.tuckerauto-mation.com](http://www.tuckerauto-mation.com)***

## APPENDIX – CHAIN TENSIONER ADJUSTMENT

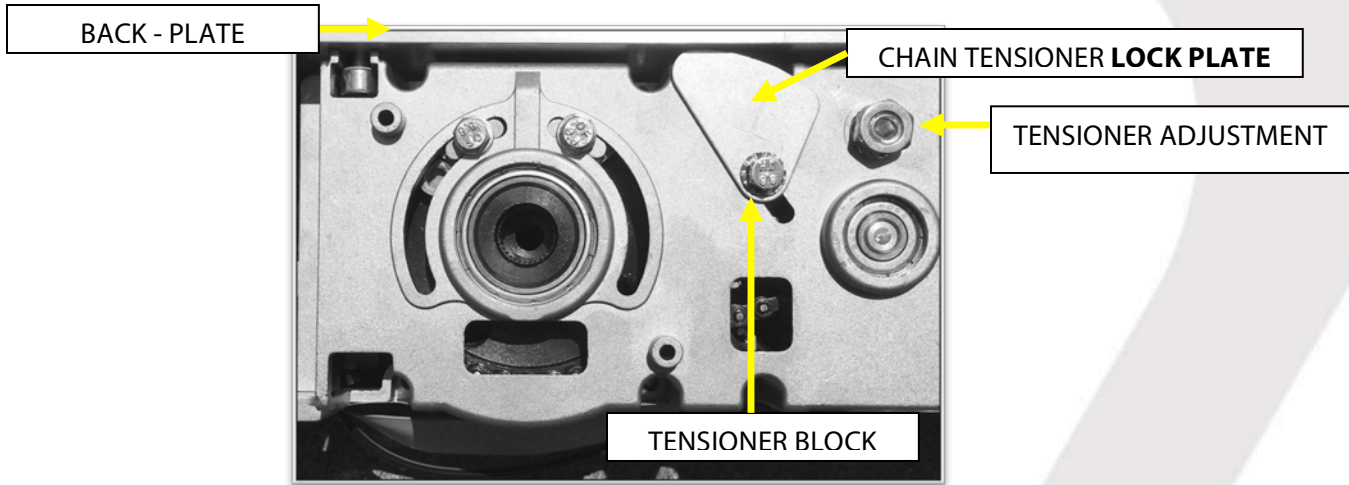

### SIGNS OF A LOOSE CHAIN TENSIONER

- Opening or Closing door movements may be erratic
- The door may reverse open on its own during the closing cycle
- When a setup is launched, the door may appear to open a few degrees at a time, especially as it is just beginning to open
- Door may not open to its full open position - it may stop short and then close, as it thinks there was an obstruction
- Operator may make a loud clicking noise - this is created by the chain jumping on the sprockets
- There may be a "lag" between operator movement and door movement - this is due to the chain "slack" being taken up before door movement
- Door may go through a setup correctly but then will show a flashing red error LED upon completion of setup, or upon the first attempt to open
- If chain is excessively loose, it is possible for the chain to become bound up on itself, thus preventing automatic door movement - this will usually happen on the closing stroke
- Abnormal noises may come from the operator as you use the door manually
- Wear marks may be evident on the body of the operator where the tensioner bolt has slipped

**ADJUSTING THE CHAIN TENSIONER**

- 1. At the tensioner pivot point, loosen the lock nut at the Tensioner Adjustment.
- 2. At tensioner block, loosen the Allen-head screw (do not remove it).
- 3. Insert 4mm Allen wrench into the tensioner adjustment and apply tension counter clockwise to increase tension on the chain.
- 4. Rotate chain tensioner lock plate clockwise so the plate is pressing against the back plate
- 5. Re-torque the tensioner block screw while maintaining chain tension - These bolts are generally torqued to around 3.7ft lbs.
- 6. Re-tighten the lock nut at the pivot point.
- 7. When complete, double check physical stops for 0 and 90 degree door position - adjust if necessary.
- 8. Launch a new setup at the control and ensure everything works ok. Any time the stroke of the operator has changed, a new setup will be required.

**APPENDIX – WIRING DIAGRAMS**

**DOOR STATUS SWITCH**

**Terminal 4:** Door “Closed” status switch: Contact closes upon full door closed position.

**Terminal 5:** Common

**Terminal 6:** Door “Open” status switch: Contact is closed when door is full open.

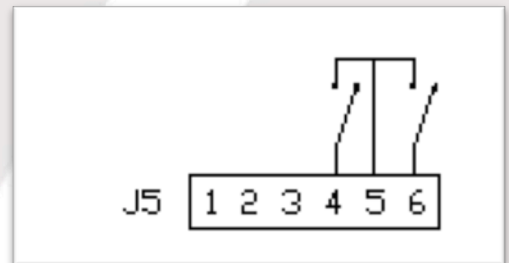

**LOW ENERGY APPLICATION: PUSH PLATES WITH APPROACH SIDE DOOR-MOUNTED SENSOR**

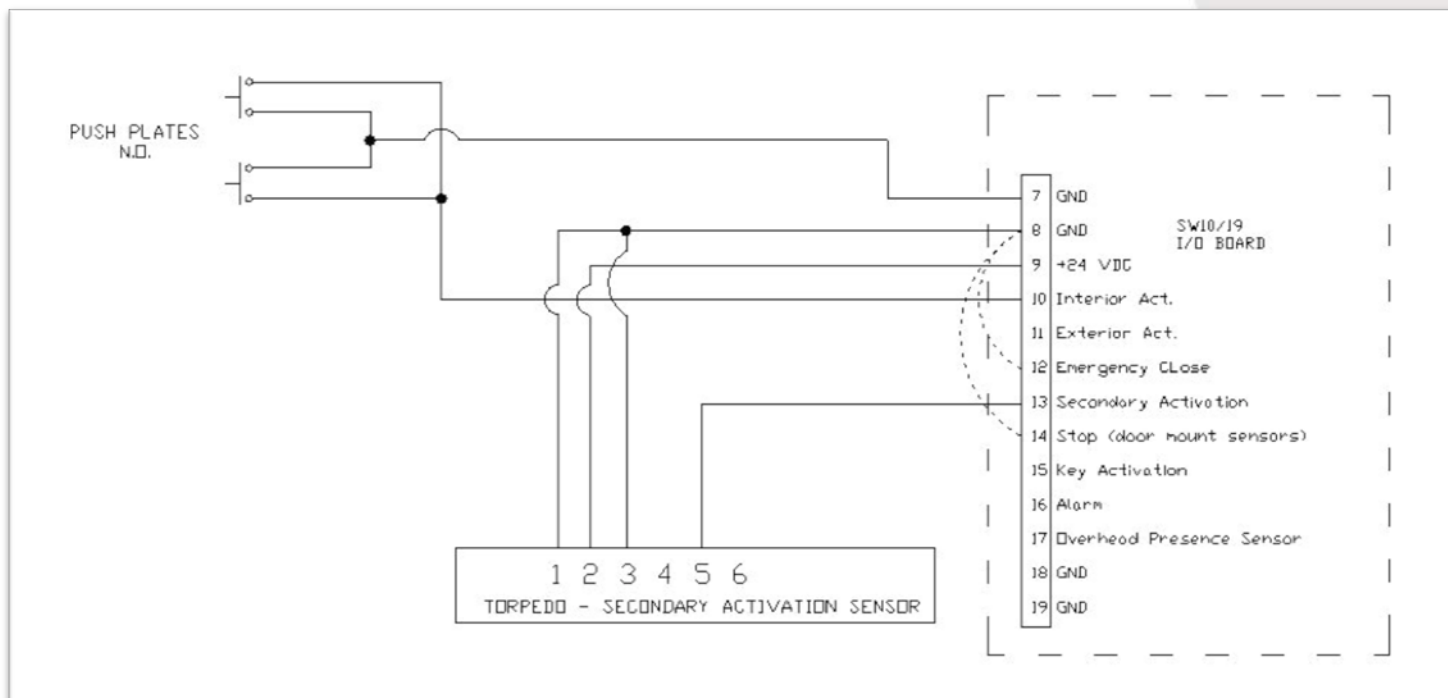

- Non-Swing Side (approach) door-mounted sensor is wired into the secondary activation input (13) at the SW19 I/O board. It is a normally closed circuit.
- Door-mounted sensor will cause re-activation when in detection during the closing cycle.
- Secondary activation input is disabled at the full closed door position.
- Jumpers must be installed between terminal 8 and 12 & 14 if those inputs are not required for the application. If they are used for the application, they must be connected to a N.C. circuit.



# APPENDIX – WIRING DIAGRAMS

## SIMULTANEOUS PAIRS

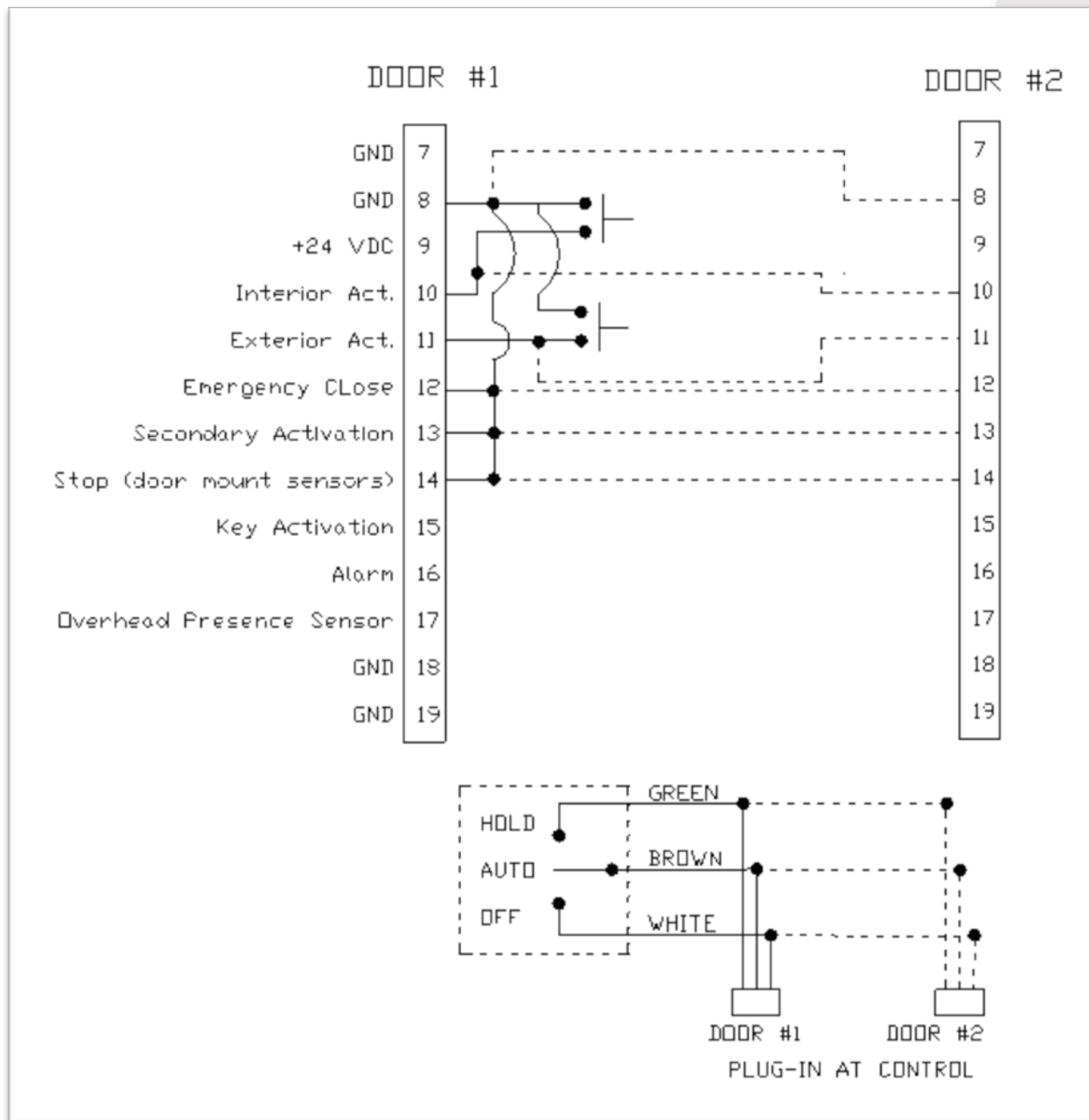

- When wiring controls for use as a simultaneous pair, all required inputs need to be sync'd (connected) between Door #1 and Door #2 (shown as dotted lines in above diagram).
- Example shown above: Push plates are connected to inputs 8, 10 and 11 at door #1 and are connected via sync line to Door #2.
- When using pairs of controls, N.C. inputs 12, 13 and 14 may be sync'd to each other, OR each control may have it's own jumpers installed. If any of these inputs are required for the application, the jumper will be removed for the respective input – in place of the jumper, a N.C. switching circuit will be connected to Door #1, and a sync line will be connected to Door #2.
- For simultaneous pairs, Tucker Auto-Mation provides a dual harness for the On-Off-Hold switch. Each plug-in connector for the control is wired in parallel to the On-Off-Hold switch located in the header end-cap. One switch will control both doors.
- All control adjustments (speed & time delay) must be made independantly at each control.
- All dipswitches at each control must be set independantly and must match between controls.
- When using the TAP programmer, settings must be made independantly at each control and must match between controls.



# APPENDIX- WIRING DIAGRAMS

## ELECTRIC LOCK APPLICATION

HOW TO CONNECT AN ELECTRIC STRIKE TO THE SW10 CONTROL

The positive leg of the electric strike is connected to terminal 2 for FAIL-SECURE applications. For FAIL-SAFE applications, use terminal 3 in lieu of terminal 2

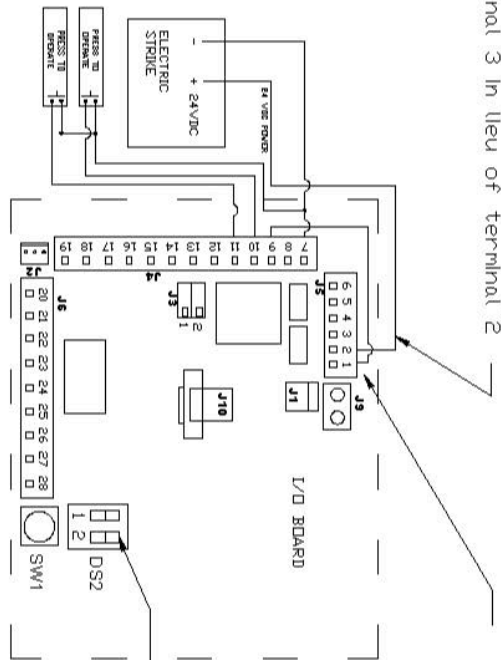

- 1 - Relay Common
- 2 - Relay Normally Open
- 3 - Relay Normally Closed

When activation is commanded, the relay is energized and completes the power loop to the strike

DIP 2 -  
DFP = 200ms Act, Delay  
DN = 500ms Act, Delay

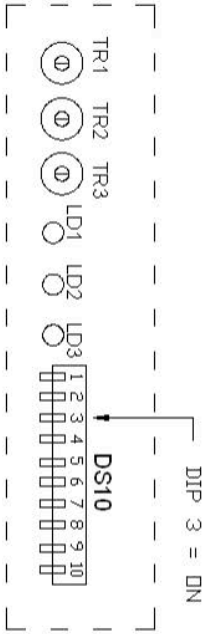

- NOTES
1. Dip Switch 3 should be DN for most typical applications.
  2. Dip Switch 2 (at DS2) can be set for 500ms only if needed.
  3. When the DFF-AUTD-Hold switch is in the AUTO position, activation will be possible at input 10 & 11.
  4. When the DFF-AUTD-Hold switch is in the DFF position, activation will be possible at input 10 only. This is the typical EXIT ONLY function.

<b>Tucker</b> AUTOMATION		TUCKER AUTO-MATION 1081 3 <sup>rd</sup> STREET NORTH VERSAILLES, PA 15137	
TITLE: SW10/19 ELECTRIC LOCK APPLICATION			
DWG#:	USERS GUIDE	REV.:	00
DRAWN BY:	JED	APPROVED BY:	SCALE: NTS
		DATE:	09/14/2014

# APPENDIX- WIRING DIAGRAMS

## SW10 PAIR WITH BEA PARALLAX SYSTEM

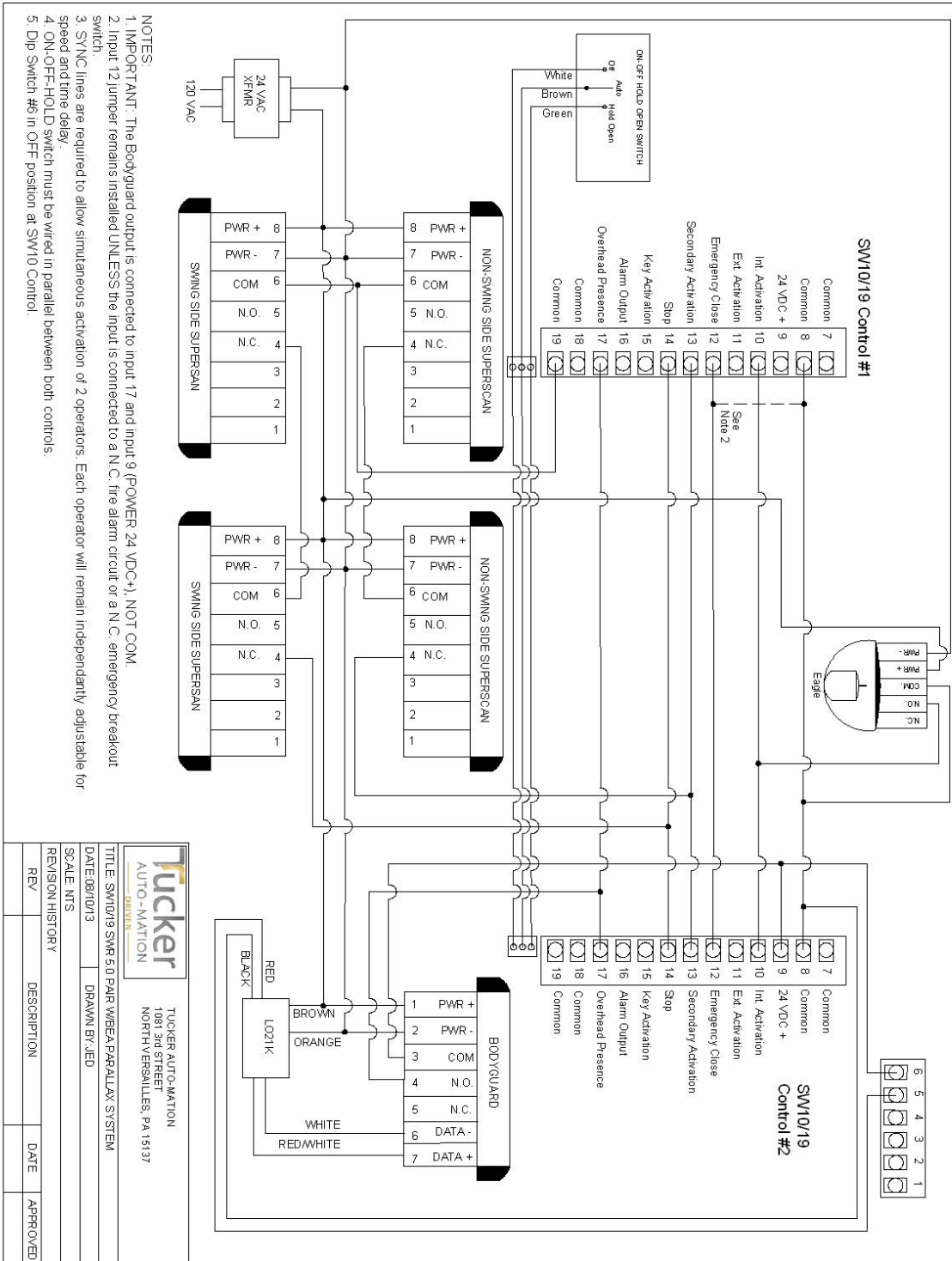

<b>Tucker</b> AUTO-MATION		TUCKER AUTO-MATION 1081 3rd STREET NORTHVERSAILES, PA 15137	
TITLE: SW10/19 SWR 5.0 PAIR W/BEA PARALLAX SYSTEM		DRAWN BY: JED	
DATE: 08/10/13		SCALE: NTS	
REVISION HISTORY		DESCRIPTION	
REV		DATE	APPROVED



## APPENDIX- WIRING DIAGRAMS

### SW10 Single / Pair With BEA LZR Microscan Sensors

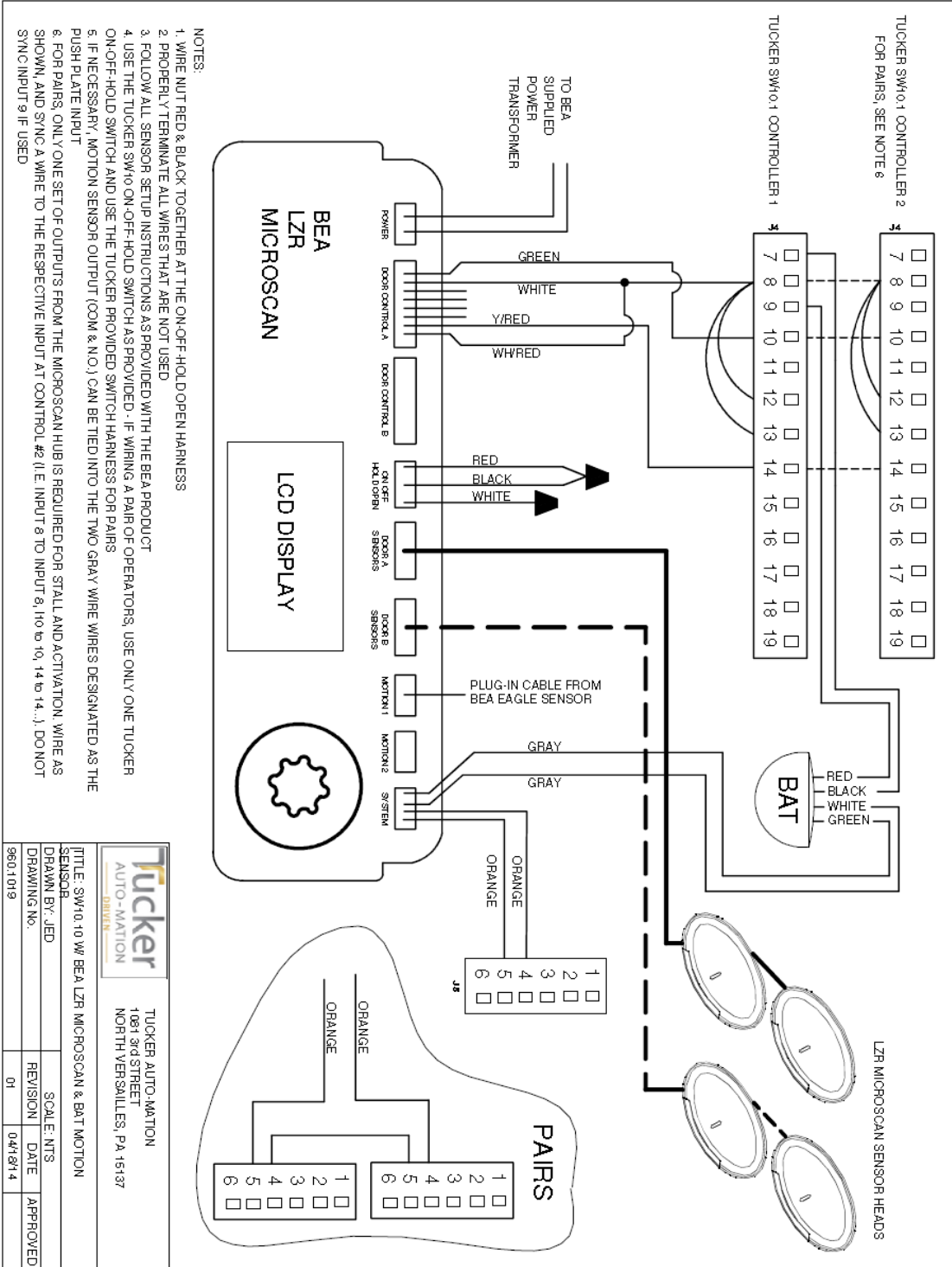

<b>Tucker</b> AUTO-MATION		TUCKER AUTO-MATION 1081 3RD STREET NORTH WENSMITH, PA 15137	
TITLE: SW10/19 W/ BEA LZR MICROSCAN & BAT MOTION		SCALE: NTS	APPROVED
DRAWN BY: JED		REVISION	DATE
DRAWING NO. 980.1019		01	04/18/14

# APPENDIX- WIRING DIAGRAMS

## SW10 Single With Push Plates & Torpedo Sensors For Secondary Activation

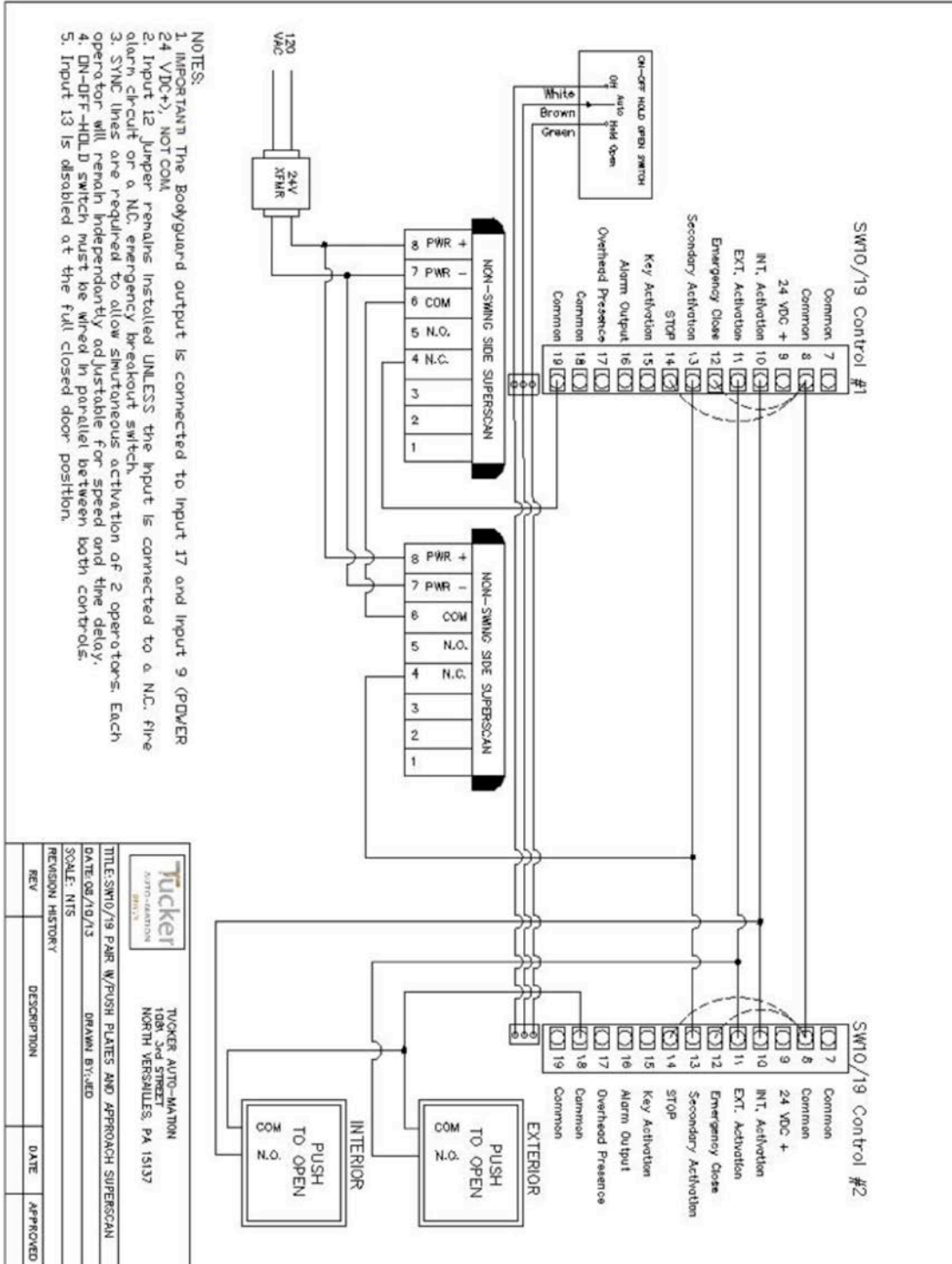

**Tucker**  
APPRO-MATION  
DRINKS

TUCKER AUTO-MATION  
 1081 3rd STREET  
 NORTH VERSALES, PA 15157

TITLE: SW10/19 PAR. W/PUSH PLATES AND APPROACH SUPERSCAN  
 DATE: 08/19/13 DRAWN BY: JED  
 SCALE: NTS  
 REVISION HISTORY

REV	DESCRIPTION	DATE	APPROVED

## APPENDIX- LOCK RELAY FUNCTION

	AUTO-OFF-HOLD SELECTOR SWITCH STATUS	DIP SWITCH 3	INPUT 10	INPUT 11	LOCK RELAY STATUS (door closed)	OPERATION	REMARKS
<b>Line 1</b>	AUTO	OFF	Active	Active	DE-Energized	Upon activation (10 or 11), lock relay energizes and door opens	This is typically the desired operation. If it is necessary to shut off all activation when selector switch is OFF AND keep door locked, place dip switch 3 ON and see Note #3.
<b>Line 2</b>	OFF	OFF	Inactive	Inactive	Energized	Placing the selector switch to OFF unlocks the door and remains unlocked. All activation is disabled.	Not typical for US market. See Remarks on Line #2.
<b>Line 3</b>	OFF	ON	Active	Inactive	DE-Energized	Upon activation (10), lock relay energizes and door opens. This serves as an "Exit Only" function. Input 11 is disabled.	Typical for exit only
<b>Line 4</b>	AUTO	ON	Active	Active	DE-Energized	Upon activation (10 or 11), lock relay energizes and door opens.	Typical for 2-way traffic

**NOTE 1:** The most common setup is Line 3 & 4(above). In this setup, input 11 is disabled when the selector switch is in the OFF position.

**NOTE 2:** Regardless of lock setup, Input 13 (secondary activation) functions normally and will shut off at closed-door position.

**NOTE 3:** If it is desired to keep door locked AND shut off ALL activation when selector switch is OFF, place dip switch 3 ON AND tie all activation into Input 11.

**NOTE 4:** Only electric strikes that are DC operated should be used. AC strikes that buzz will maintain the buzzing noise until door gets fully closed again. The lock voltage is applied at activation and not released until the next closed door position.

**NOTE 5:** When selector switch is placed in Hold-Open position, lock relay remains energized.

**NOTE 6:** If desired lock performance is beyond capability of the SW10 control, Tucker Auto-Mation recommends the use of a BEA BR-3 Module.

## APPENDIX- FIRE RATED DOOR APPLICATION

- Perform the installation according to the instructions outlined in this manual. Additionally, ensure the following conditions have been met:

- When attaching the door arm to the door, use steel binding posts (Sex Bolts) to attach. Do NOT use sheet metal screws into the face of the door. The door arm bracket must be through-bolted.

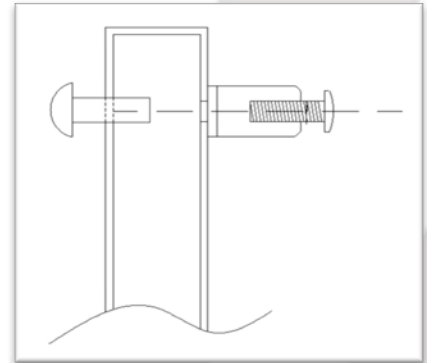

- When attaching the header to the hollow metal door frame, ensure there are 5 attaching screws spaced equally apart. They should be #12 sheet metal type screws.

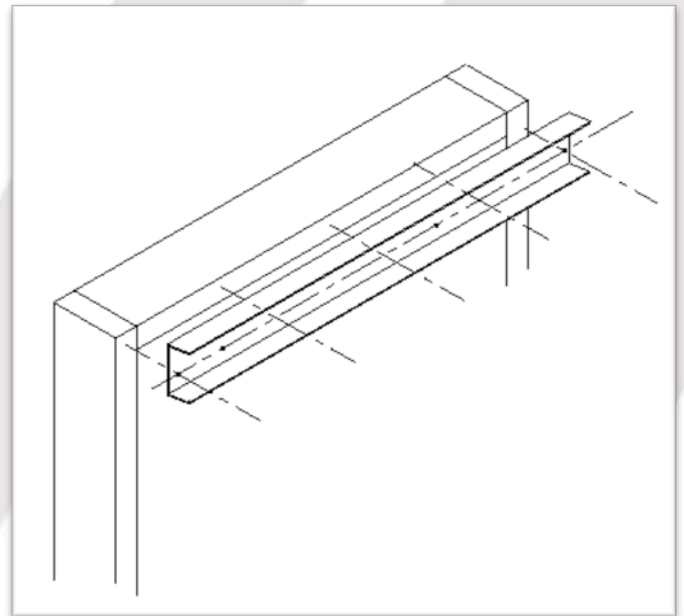



- Fire rated power operated doors must close and latch during a fire alarm condition. Ensure proper procedures have been followed to allow a main power disconnect during a fire alarm condition. Always check to ensure compliance to local building codes.
  - Upon job completion, always perform a functional test to ensure that the door(s) close and latch following a power loss.
- Other hardware may be required to complete the installation. For example, for pairs of doors, if an Astragal is installed, a mechanical door coordinator may be required to ensure a proper coordinated closing during a power loss.
- Only fire rated hardware shall be used on a fire rated door & frame assembly.
- Ensure the Tucker SW10/19 that is being installed has the proper fire rated label applied to the header.

## APPENDIX- TUCKER LOGO

