

**Pro-Care™ Series 8300 Sliding Door
Installation Instructions
Quick-Reference Guide**

204142

Rev. B, 06/13/2017

Prohibition on Copying

Any unauthorized reproduction, disclosure or distribution of copies by any person of any portion of this work may be a violation of copyright law of the United States of America and other countries, could result in the awarding of statutory damages of up to \$250,000 (17 USC 504) for infringement, and may result in further civil and criminal penalties. All rights reserved.

Quick-Reference Guide

TABLE OF CONTENTS

1. PURPOSE 2

1.1 Discussion 2

1.2 Applicability 3

2. PREREQUISITES 4

3. INSTALLATION INSTRUCTIONS 4

3.1 Checking the Rough Opening 4

3.2 Attaching Jambs to the Header 6

3.3 Installing the Header and Jamb Assembly 6

3.4 Installing the Bottom Pivot Plate 7

3.5 Installing the SO Panel 8

3.6 Installing the SX Door Panel 11

3.7 Performing Final Adjustments 15

3.8 Installing the Handle Assembly 19

3.9 Installing Self Closer/Damper Kit (Optional) 21

3.10 Proper Glass Blocking of Door 25

3.11 Performing the Closeout Procedure 26

3.12 Swing Latch Adjustment 27

Attachments

Attachment 1: Documents, Definitions, Tools, Equipment, Materials, and Consumables 28

Attachment 2: Replacement Parts 29-31

WARNING

Proper glass blocking is CRITICAL to ENSURE proper door function. See Section 3.10 for proper glass blocking instructions.

1. PURPOSE

1.1 Discussion

This manual provides installation instructions for the Stanley Pro-Care Series 8300 trackless door with utility breakout. The Series 8300 is a two-panel manual door system. See Figure 1.

Figure 1: 8300 Assembly (RH Shown)

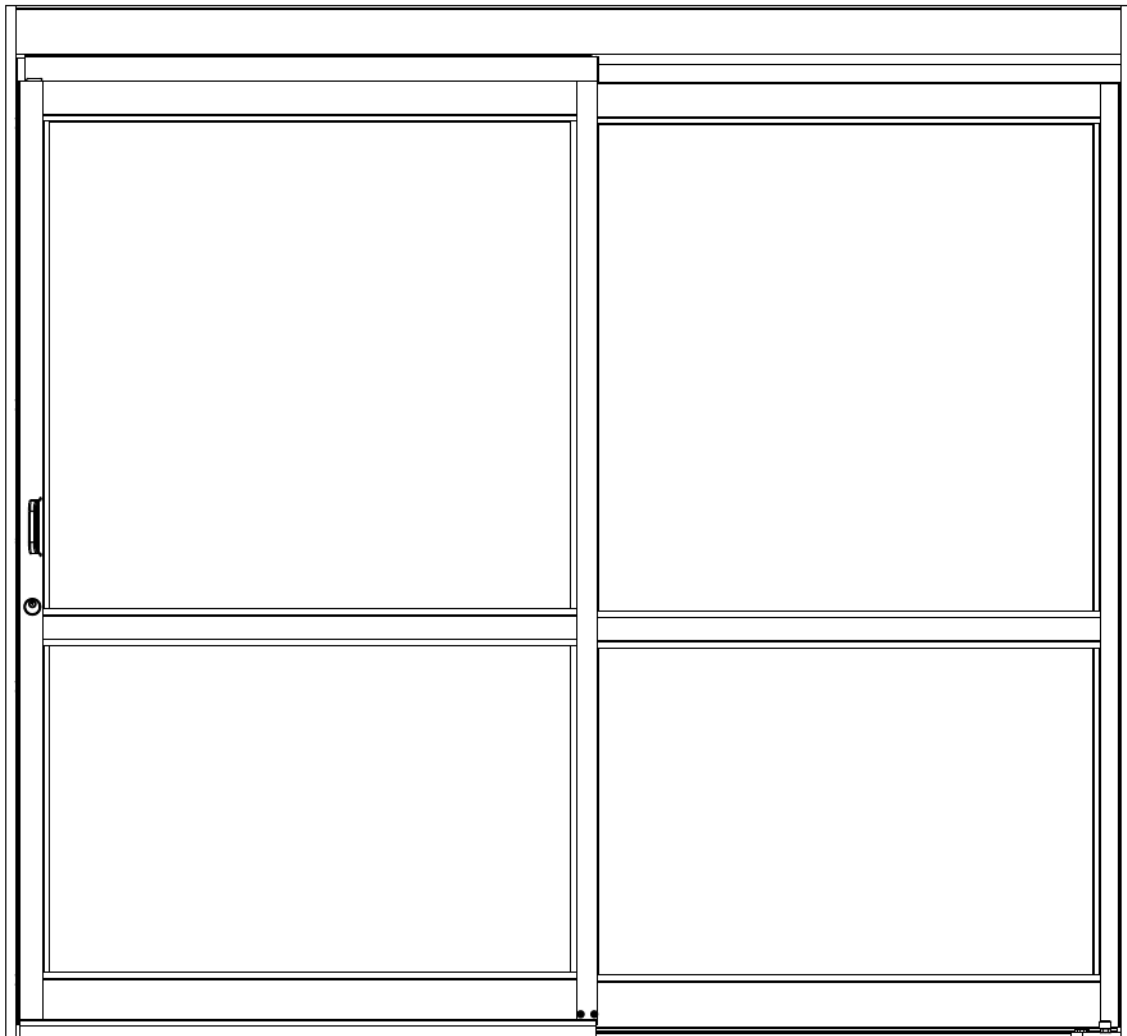

With the ICU smoke and draft control option kit installed, the air leakage rates shown in Table 1 can be achieved.

Table 1: Air Leakage Rates

Pressure (in. of WC)	Air Temp, °F	Leakage (cfm/sq ft)	Closing Force, lb	Artificial Bottom Seal
0.05	Ambient	1.5	3.8	No
0.10	Ambient	2.1	3.8	No
0.20	Ambient	3.20	3.8	No
0.30	Ambient	4.22	3.8	No
0.05	400	0.28	3.8	No
0.10	400	0.77	3.8	No
0.20	400	1.21	3.8	No
0.30	400	1.70	3.8	No
Pressure (in. of WC)	Air Temp, °F	Leakage (cfm/sq ft)	Closing Force, lb	Artificial Bottom Seal
0.05	Ambient	0.532	3.8	Yes
0.10	Ambient	0.777	3.8	Yes
0.20	Ambient	1.4	3.8	Yes
0.30	Ambient	1.7	3.8	Yes
0.05	400	0.0709	3.8	Yes
0.10	400	0.340	3.8	Yes
0.20	400	0.51	3.8	Yes
0.30	400	0.80	3.8	Yes

1.2 Applicability

This manual is applicable to the Stanley Pro-Care Series 8300 sliding door system. This manual does not cover retrofit of an existing door system.

2. PREREQUISITES

Protective barrier (caution/warning tape) has been set up to prevent unauthorized access to work area.

Attachment 1 has been reviewed for the following:

- a. Definitions of the terms used in this procedure
- b. A listing of the additional documents required during this procedure
- c. A listing of the tools, equipment, materials, and consumables used in this procedure.

3. INSTALLATION INSTRUCTIONS

3.1 **Checking the Rough Opening**

3.1.1 ENSURE floor is level across the entire opening.

NOTE

Opening width should be package width plus ½" (¼" each side for shim and caulk clearance). This clearance can be as small as ⅛" for a tight appearance with the aluminum storefront construction.

3.1.2 CHECK opening width and height from finished floor.

3.1.3 ENSURE area is clean and clear of debris.

3.1.4 **IF the smoke and draft kit is required**, then refer to Figures 2 and 3, and PERFORM the following:

- a. Refer to Figure 2 and REMOVE three bolts and washers securing the fixed rail to the header, and REMOVE the fixed rail.
- b. CUT the SO panel top seal to the length of the SO panel fixed rail.
- c. Using glass cleaner or isopropyl alcohol, CLEAN the header lip in the area where the SO panel fixed rail will touch.
- d. APPLY adhesive backed seal to the header lip behind the fixed rail.
- e. Reinstall the three bolts and washers to secure the SO fixed rail back to the header.

Figure 2: Removing the Fixed Rail from the Header

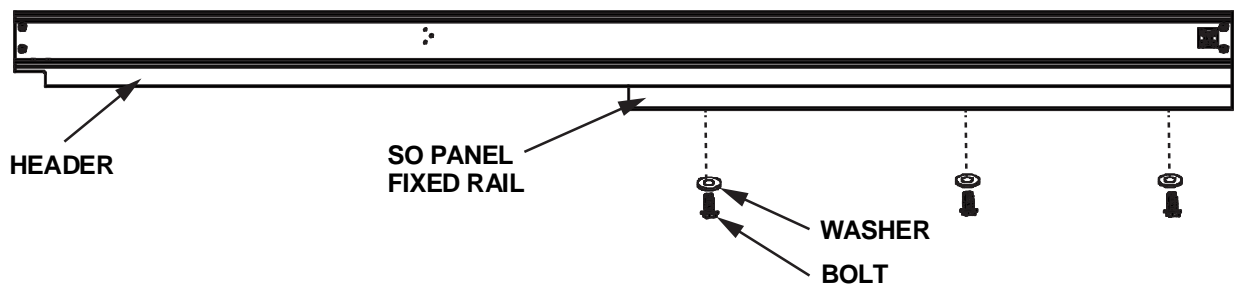
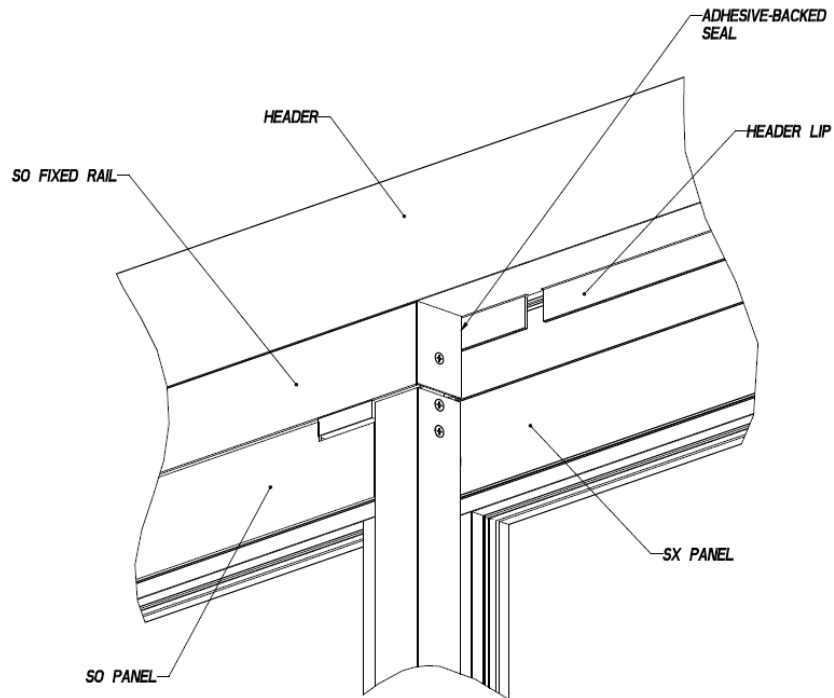

Figure 3: Preparing the Header for the Adhesive-Backed Seal



NOTE

Jamb brackets are fastened to the header at the factory.

Figure 4: Attaching the Jambs to the Header

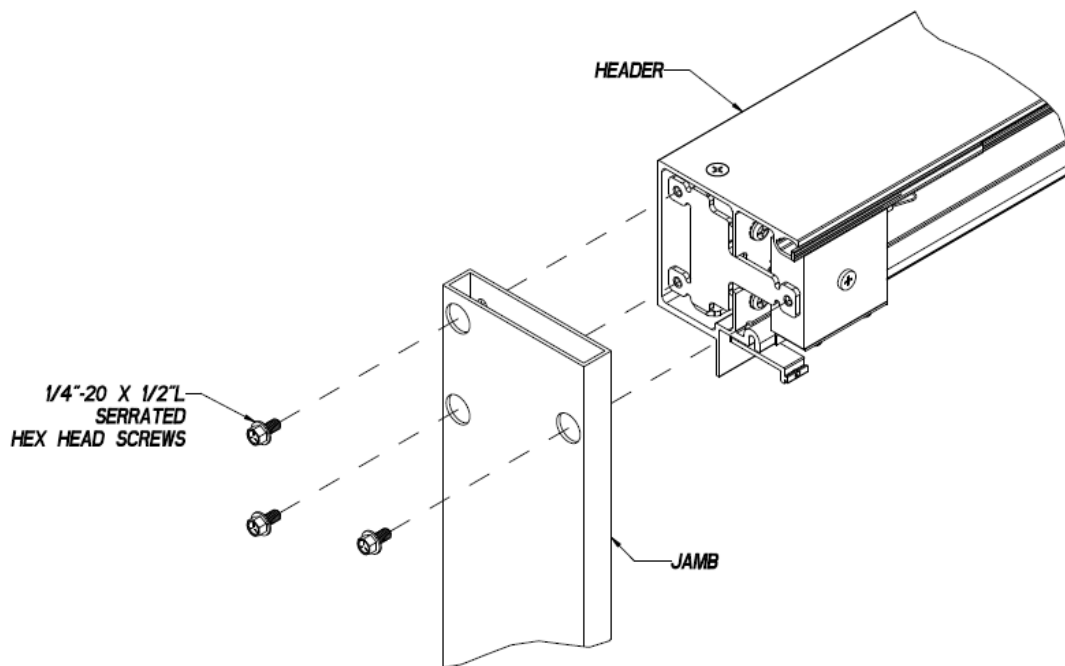

3.2 Attaching Jambs to the Header

- 3.2.1 Refer to Figure 4 and POSITION the end of header to the jamb.
- 3.2.2 Using three $\frac{1}{4}$ -20 X 1" L serrated hex head screws, ATTACH header to the jamb.
 - a. The hardware is found in the ICU Jamb Mounting Kit (314281 or 344281)
- 3.2.3 REPEAT for opposite end of header.

3.3 Installing the Header and Jamb Assembly

NOTE

When determining the proper orientation of the header cover, the header cover must open in the same direction that the door swings out. For example, if the header cover opens to the inside of the building, the door will swing out to the inside.

- 3.3.1 DETERMINE proper orientation of header cover with respect to breakout direction.
- 3.3.2 LIFT header and jamb assembly and POSITION into opening. Ensure cover is installed.
- 3.3.3 Temporarily SECURE frame in place as necessary to prevent header and jamb assembly from falling.
 - a. Route any building ground connection wire through the top of the jamb tube as necessary. The jambs have a clearance hole for the ground wire access. Deburr any sharp edges to prevent the grounding wire from chaffing or breaking.
 - b. A grounding cable is factory installed to the jamb mounting bracket.
 - c. Use the correct wire nut, secure the building grounding wire to the header grounding cable. The wire nuts are found in the jamb mounting kit (314281/344281).
- 3.3.4 SHIM beneath jamb(s) as necessary to level header and maintain required height from highest point of finished floor.
- 3.3.5 INSPECT one jamb for plumb in vertical and horizontal planes. IF required, SHIM back of jamb.
- 3.3.6 Refer to Figure 5 AND Table 2. Using the factory drilled jamb holes as a guide, DRILL holes in rough opening for the following fasteners as required:

Table 2: Jamb Installation Fastener Size and Type

Rough Opening	Fastener Size/Type	Embedded Minimum Depth
Concrete	Concrete Screw	1-1/2"
Steel	#14/SMS (18 GA Steel Min.)	As Necessary
Wood	#14/Wood Screw	1-1/2"

Figure 5: Installing the Header and Jamb Assembly (Cover Not Shown)

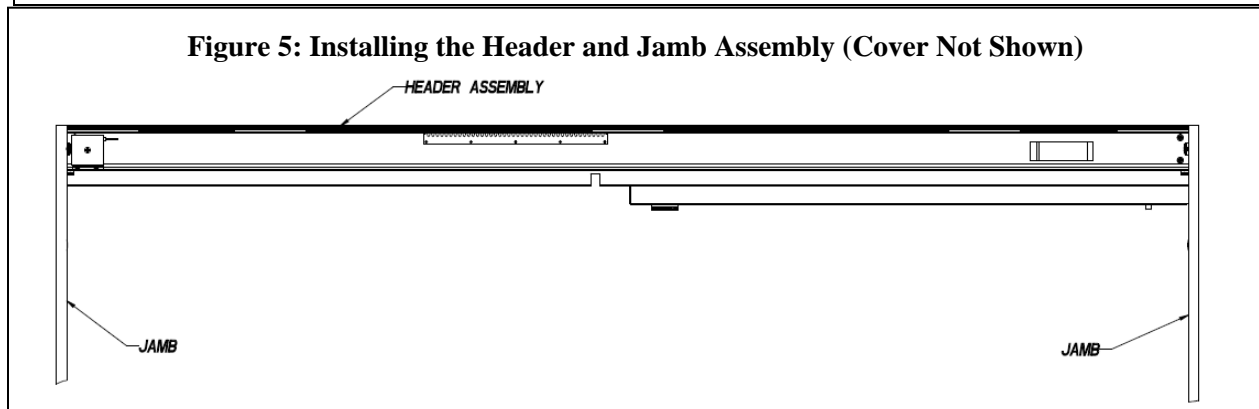

204142

Rev. B, 06/13/2017

6 of 31

- 3.3.7 INSTALL, but do *not* tighten, fasteners securing one jamb to opening, and ENSURE jamb remains plumb.
- 3.3.8 REPEAT for opposite jamb.
- 3.3.9 Starting at the top of jamb and moving downward, SHIM jambs as necessary to ensure jambs remain level and plumb, and TIGHTEN fasteners securing jambs to opening.
- 3.3.10 INSTALL and TIGHTEN any fasteners securing header to opening, and ENSURE header remains level.
- 3.3.11 INSTALL jamb plugs to conceal jamb mounting fasteners.
 - a. Plugs found within the ICU Jamb Mounting Kit (314281 or 344281)
- 3.3.12 INSTALL jamb inserts if applicable

3.4 Installing the Bottom Pivot Plate

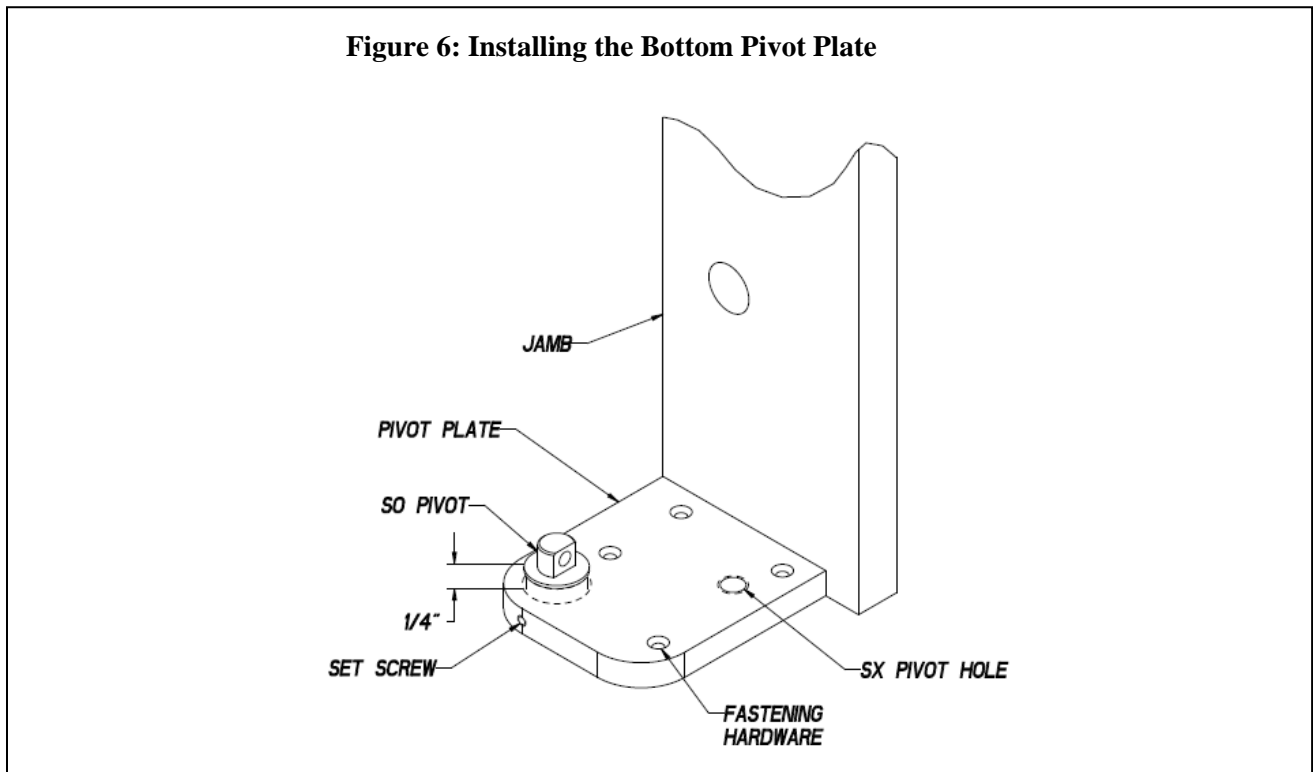

- 3.4.1 Refer to Figure 6 and THREAD the SO pivot into the pivot plate such that the top of the adjusting screw shoulder is $\frac{1}{4}$ " above the top of the plate.
 - a. SO Pivot found within the ICU Jamb Mounting Kit (314281 or 344281)
 - b. SO Pivot Plate found within the 2-Panel ICU Hardware Kit (314285)
- 3.4.2 Refer to Figure 6 and ALIGN the pivot plate to be flush with the backside of the jamb towards the SO panel.
 - a. ENSURE that the SO pivot is plumb with the SO pivot hole in the fixed rail.
 - b. Using the predrilled countersunk holes in the bottom pivot plate as a guide, DRILL bottom pivot mounting holes into floor.
 - c. FASTEN the pivot plate to the floor.

204142
 Rev. B, 06/13/2017
 7 of 31

3.5 Installing the SO Panel

3.5.1 INSTALL weatherstrip on SO pivot stile and on face of lead SO stile.

3.5.2 INSTALL the SX/SO – Panel Stile Overlap Seal

- a. Refer to Figure 7 and INSERT the overlap seal (bubble shape) into the slot on the face of the lead SO and pivot SX stile.
- b. PEEN the overlap seal slot on both ends to prevent the seal from moving up or down.
- c. Ensure the overlap seal on the SO panel is inserted above the spacer.

Figure 7: Installing the SO/SX –Panel Stile Overlap Seal

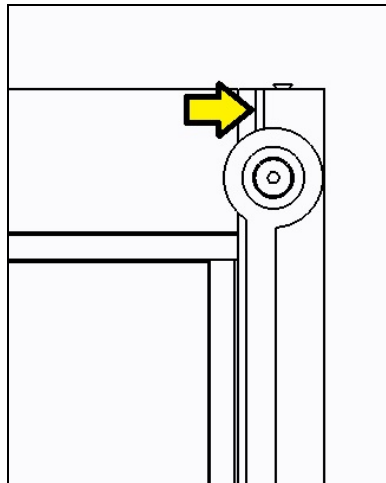
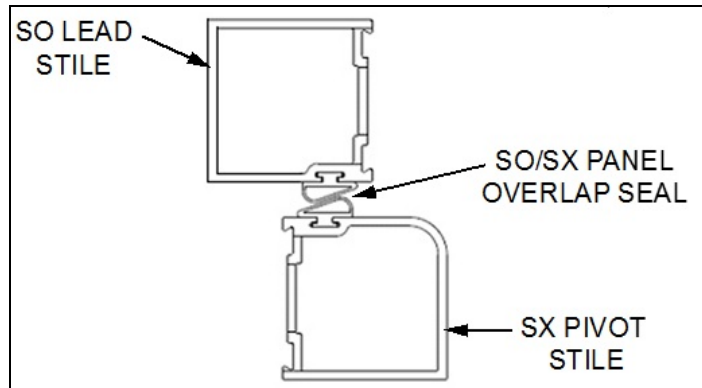

NOTE

If necessary, apply soapy water to the back of the seal for ease of installation.

3.5.3 TURN the SO pivot and ENSURE that the pivot flat is parallel with the header.

3.5.4 POSITION SO panel vertically and perpendicular to the header.

3.5.5 POSITION bottom of panel onto the bottom pivot, and ENSURE the following:

- a. The SO pivot flat aligns with the cleat in the bottom rail.
- b. The bottom rail is pushed firmly against the SO pivot.

204142

Rev. B, 06/13/2017

8 of 31

Figure 8: Installing the SO Panel

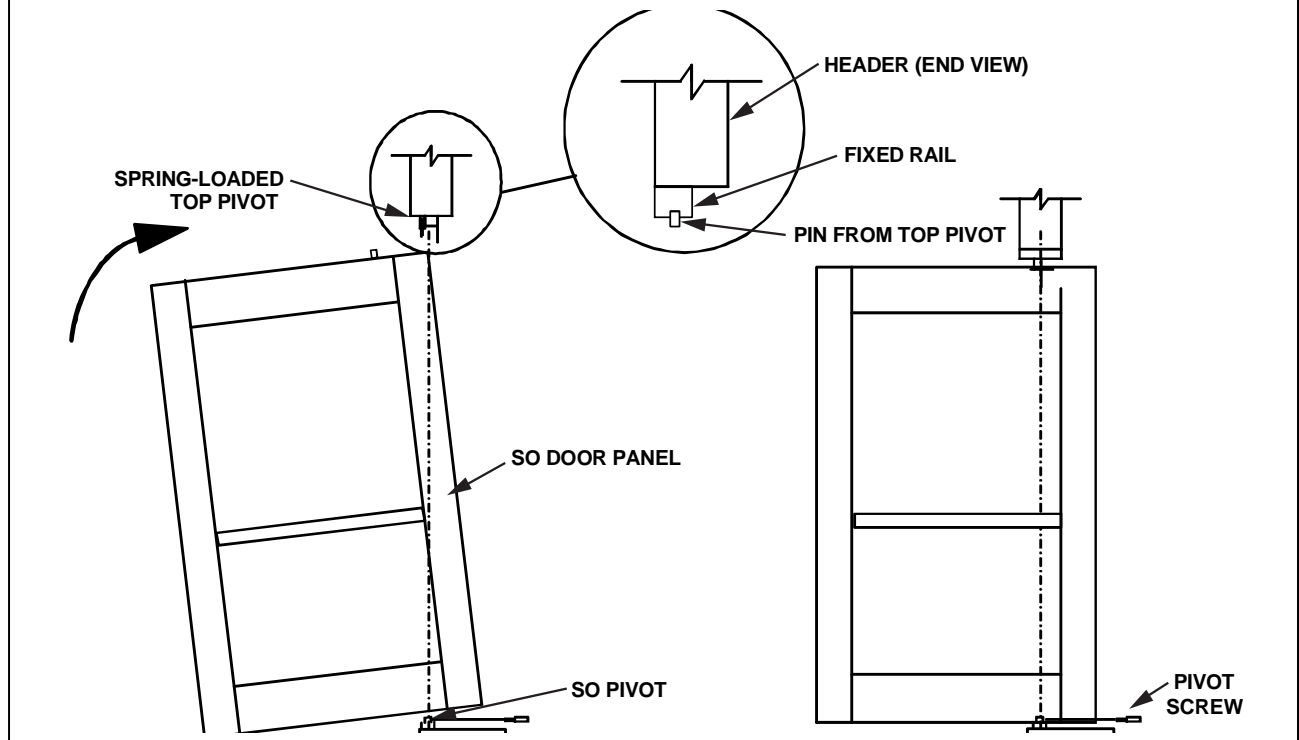

- 3.5.6 PRESS the spring-loaded top pivot upward.
- 3.5.7 Refer to Figure 8 and TILT the SO panel upward and forward until the spring-loaded top pivot engages with the pivot in the SO panel top rail.
- 3.5.8 Refer to Figure 8 and using the screw provided, FASTEN the SO panel to the SO pivot.
 - a. The bottom pivot screw is found in the 2-Panel ICU Hardware Kit (314285)
- 3.5.9 Refer to Figure 6 and TIGHTEN the #10-24 set screw securing bottom pivot to pivot plate.
- 3.5.10 POSITION the SO door in the fully closed position.
- 3.5.11 INSTALL glass into the SO panel.
 - a. See 3.10 Proper Glass Blocking of Door
- 3.5.12 ENSURE glass stops correctly positioned with respect to the door application.
- 3.5.13 If necessary, ALIGN SO panels vertically as follows:
 - a. LOOSEN screws adjacent to top pivot in fixed rail.
 - b. ALIGN SO panel and ENSURE that panel is level and plumb.
 - c. TIGHTEN screws adjacent to top pivot in fixed rail.
- 3.5.14 Install the SX Bottom guide as shown in Figure 9.

Figure 9: Installing SX Bottom Guide (RH Shown)

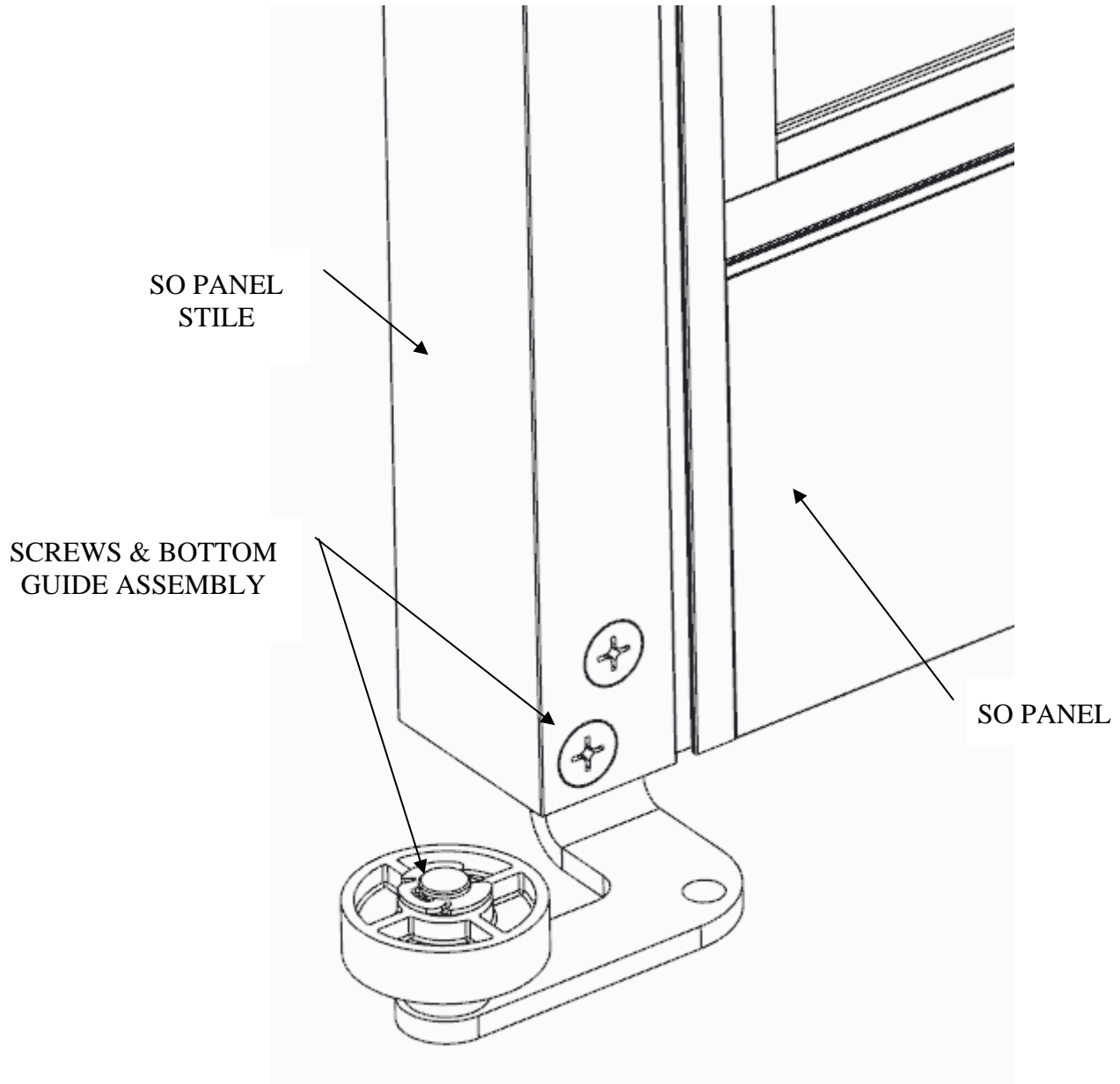

3.6 Installing the SX Door Panel

- 3.6.1 The one overlap seal on the face of the SX pivot stile and the two seals on the SX lead stile are shipped loosely in the weatherstrip and seal kit (314128-1). Install these seals in the field.
- 3.6.2 Loosen the cover latch screws at each end of the header and open the cover (Refer to Figure 26). Secure the cover in the open position for access.
- 3.6.3 **If smoke and draft kit option is required**, then refer to Figure 10 and **INSTALL** the SX panel hanger seals.

Figure 10: Installing the SX Panel Hanger Seal (Smoke and Draft Kit Option)

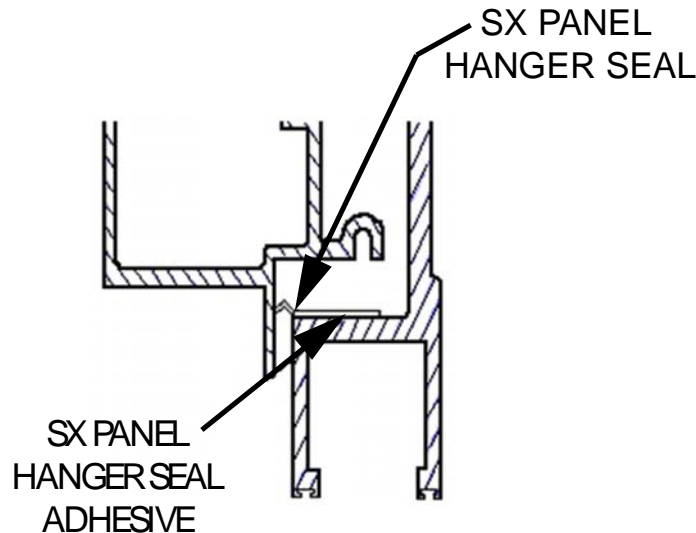

NOTE

If the seal is not oriented correctly, a stiff wire or long thin screwdriver can be inserted between the hanger and header lip and slid along the entire length of the panel. This will cause the hanger seal lip to rest in the proper orientation.

- a. Using Windex or equivalent isopropyl alcohol, **CLEAN** the following:
 - 1) The flat hanger surface below the load wheels where the hanger seal will be attached **AND** clean the hanger seal.
- b. **APPLY** the hanger seal adhesive and the hanger seal to the hanger. **ENSURE** the following:
 - 1) The formed leg extends past the hanger.
 - 2) The flat portion of the hanger seal is aligned with the edge of the hanger.
 - 3) The hanger seal protrudes approximately ¼" past the hanger edge. (This will ensure that the hanger edge will properly seal against the header lip.)
 - 4) **TRIM** the seal so that it is flush with each end of the hanger.

- 3.6.4 Refer to Figure 11 and install the SX Pivot stud, jam nut, and detent to the bottom pivot plate. For ease of installation, the SX pivot can be installed after the SX panel is hung.

Figure 11: Installing the SX Pivot

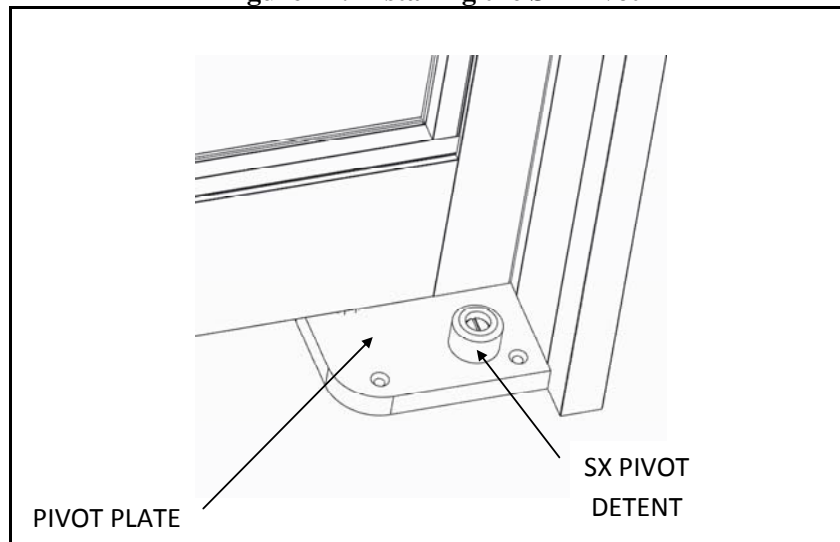

- 3.6.5 With the SX panel on a saw horse or platform, use an Allen Key and wrench to SET the load wheels to the midrange of travel position on the hanger. In this position, the top of the load wheel is 1/16" below the top of the hanger. See Figure 12 below.
- a. For door packages equipped with the dual closer option, replace the standard load wheels with the low-friction load wheels found in the ICU Dual Closer Kit (314284).
- 3.6.6 LOOSEN the anti-riser hex bolts and SET the anti-risers so that the top surface is flush with the top of the hanger. See Figure 12 below.

Figure 12: Setting Load Wheels & Anti-Risers

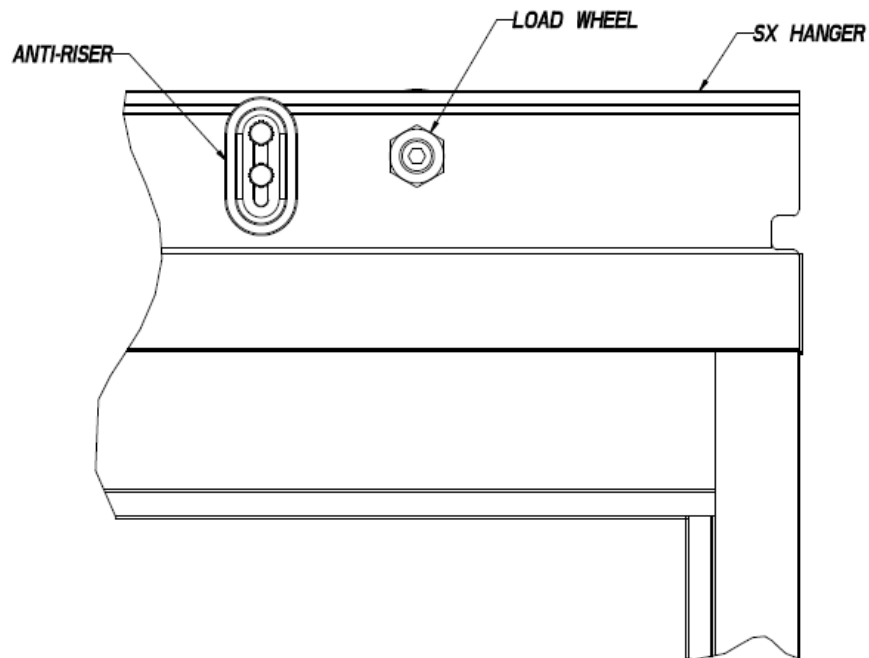

- 3.6.7 Refer to Figure 13 and the LIFT SX panel up and position the SX bottom rail above the SO Bottom Guide Wheel.

Figure 13: SX Bottom Guide in SX Panel Bottom Rail

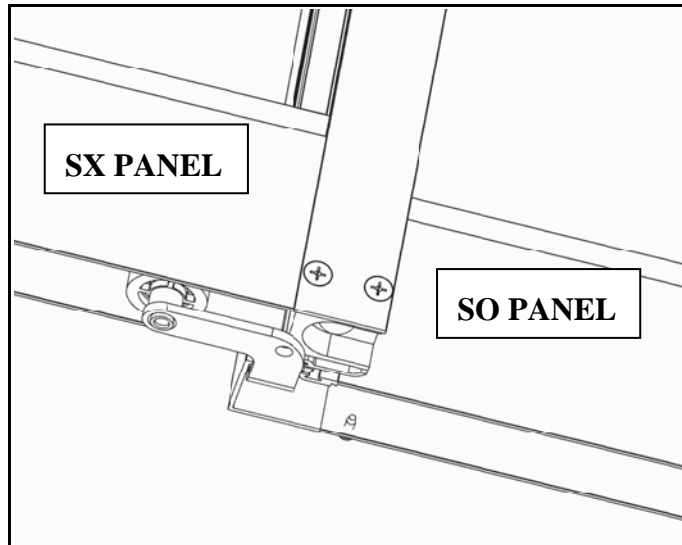

- 3.6.8 Move the SX panel to ALIGN the SX Endplate with the header notch. Push the SX Endplate through the header notch and lift the panel to engage the load wheels onto the header track.

Figure 14: SX Panel Installation (Cover Not Shown)

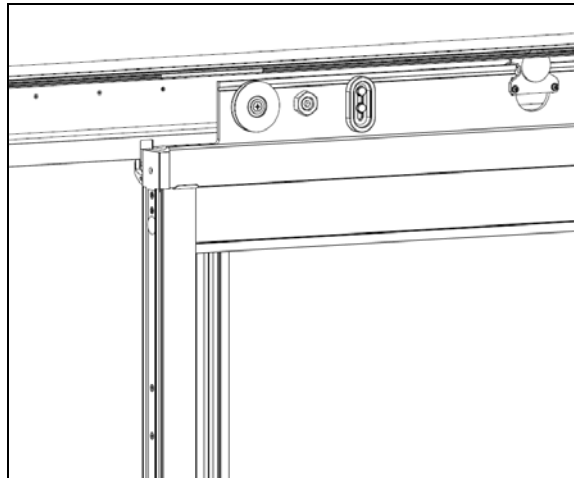

- 3.6.9 INSTALL glass into the SX Panel.
- See 3.10 Proper Glass Blocking of Door
- 3.6.10 Refer to Figure 12 and USE an Allen Key and wrench to SET the load wheels to the proper travel position in the hanger. In this position, the top of the load wheel is 1/16" below the top of the hanger.
- 3.6.11 Refer to Figure 12 and SET the hanger anti-risers so there is a 1/64" to 1/32" gap between the top of each anti-riser and the header.
- 3.6.12 Refer to Figure 11 and adjust the SX pivot detent to provide proper retention of the SX panel then tighten the jam nut.

- 3.6.13 **IF smoke and draft kit option is installed**, slide the SX panel back and forth, and DETERMINE if there is excessive resistance or noise resulting from the installation of the hanger seal.
- a. If excessive resistance or noise is observed, PERFORM the following:
 - 1) Visually INSPECT the orientation of the seal by looking from the end of the seal.
 - 2) ENSURE that the seal acts like a spring and folds so that the tip is pointing down as shown in Figure 10.
 - 3) If necessary, ADJUST the seal so that it is oriented properly.
 - 4) If any load wheel adjustment was needed to remove/install the SX-Panel, ENSURE that the SX panel is properly aligned and the anti-risers are properly adjusted.
- 3.6.14 **IF smoke and draft kit option is required**, INSTALL the four SX and SO panel top rail seals as shown in Figure 15.
- a. ENSURE the following:
 - 1) The seals extend the full width of the rails, and are trimmed flush.
 - 2) INSTALL the plastic end caps and foam end cap seals after installation.

Figure 15: Installing the SX and SO Top Rail Seals (Smoke and Draft Option)

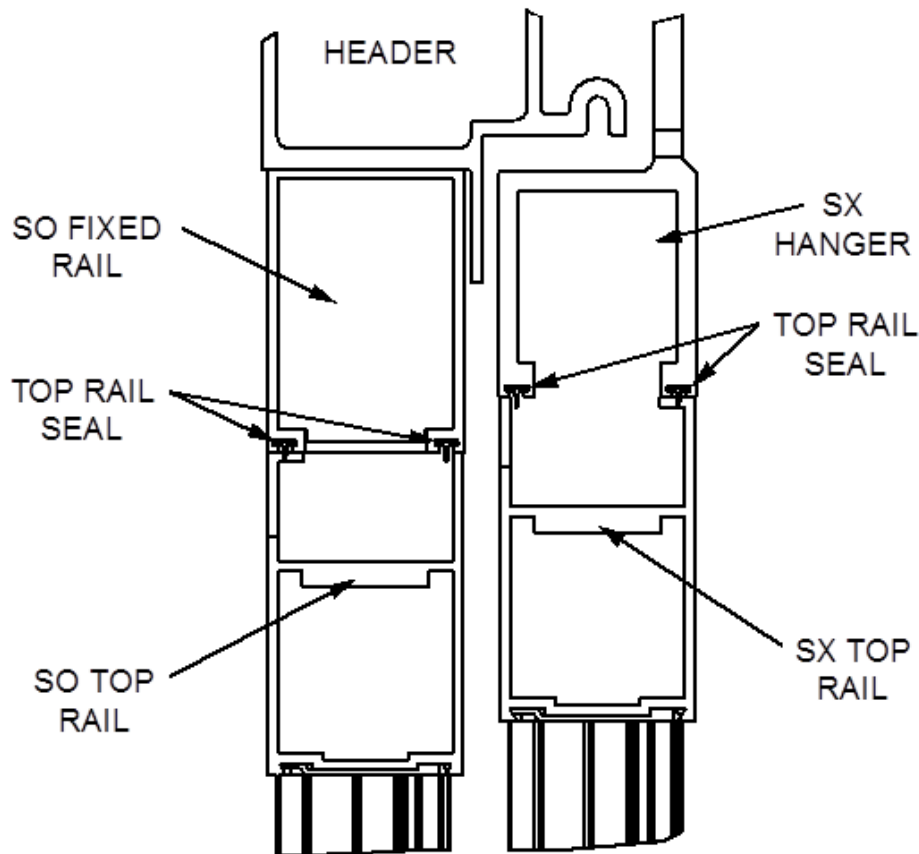

3.7 Performing Final Adjustments

3.7.1 Refer to Figure 16 and ADJUST the SX and SO bottom pivots. ENSURE the following:

- Vertical leading edges of the lead panels overlap squarely and evenly along entire height of panels.
- Tops and bottoms of panels are horizontally even.
- The gap between the panels and jambs is even along the entire height of the panels.
- Check alignment of swing interlock with header notch at full open. Plumbness of SX panel and engagement of SX bottom pivot is critical to alignment of this notch.

Figure 16: Aligning the Panels

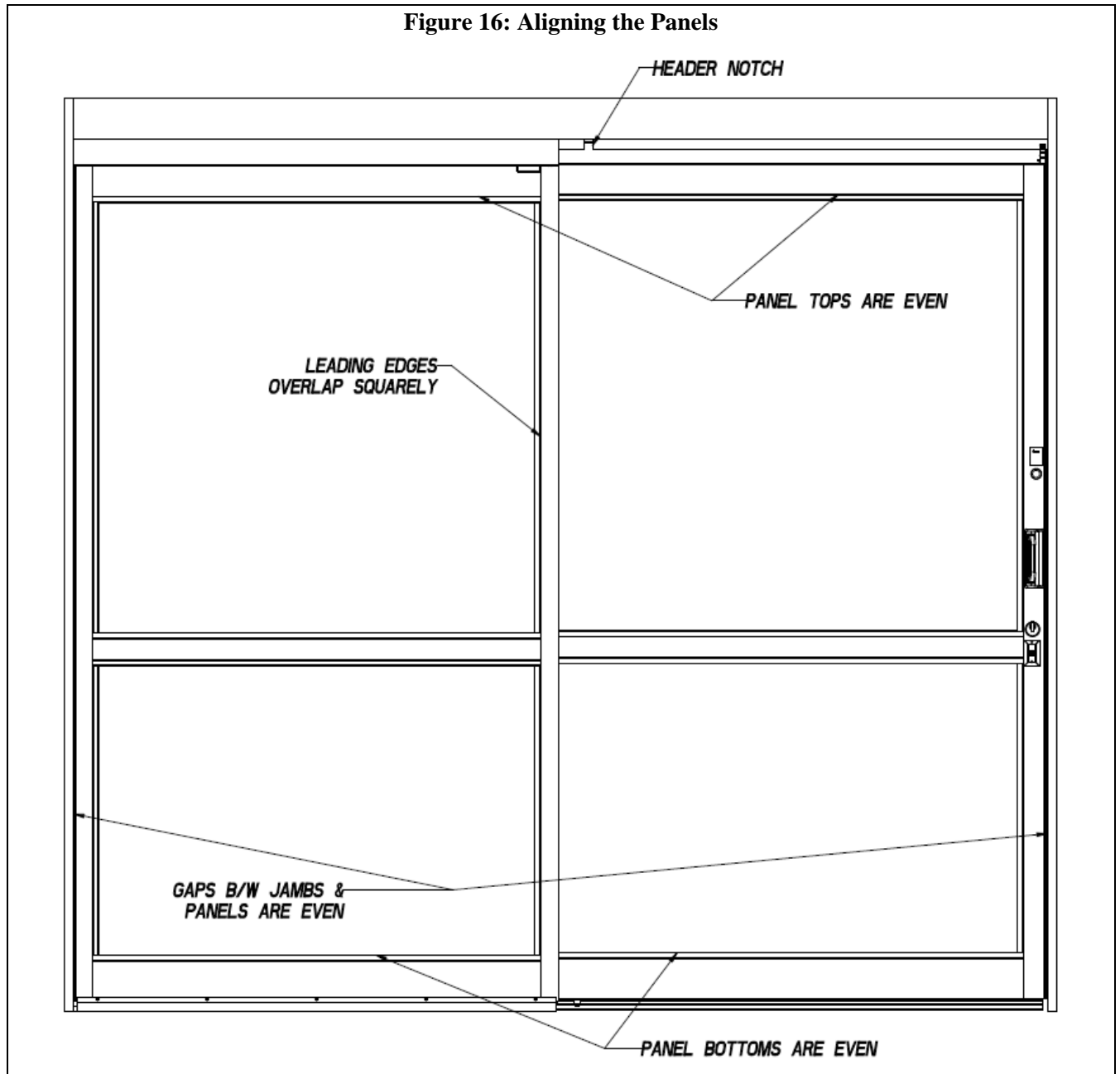

204142
Rev. B, 06/13/2017
15 of 31

3.7.2 **If Bottom Seal Leakage Rated Option is required, INSTALL the SX bottom sweep as shown in Figure 17 & 18.**

Figure 17: Installing the SX Panel Bottom Sweep

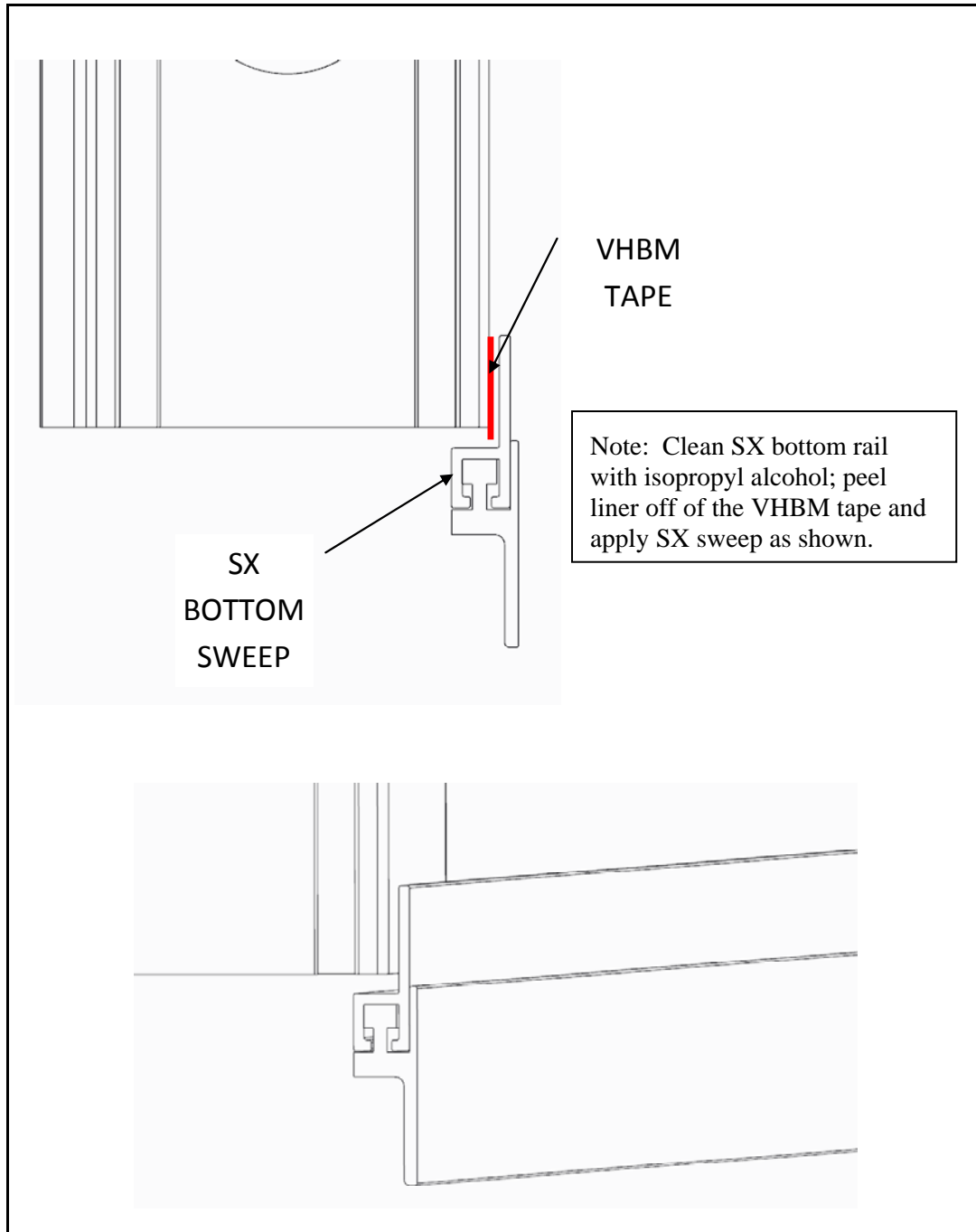
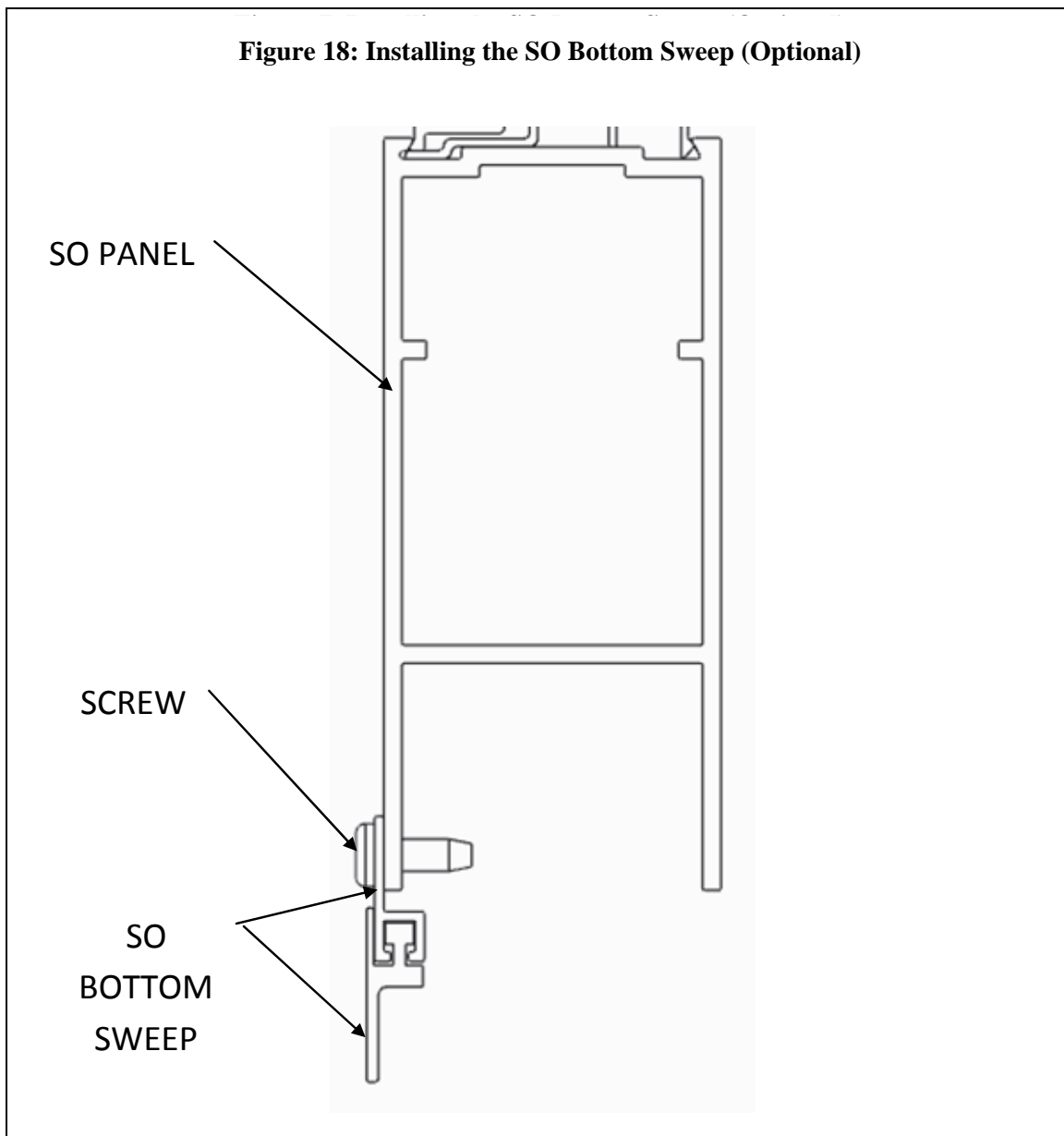

Figure 18: Installing the SO Bottom Sweep (Optional)



3.7.3 CYCLE SX panel several times and ENSURE the following:

- a. Door self-closer brings door to full close. (If self-closer option is installed)
- b. Door latches properly. (If positive latch option is installed)
- c. Door locks engages properly. (If 1-point lock option is installed)

3.7.4 SLIDE the SX panel fully open to align the SX endplate with the header notch, then push the swing out button towards the SX panel and verify that the panels swing out.

- a. For proper swing function, the SX top pivot should be adjusted to compensate for panel sag (Use $\frac{1}{4}$ " allen and $\frac{1}{2}$ " wrench).
- b. After SX top pivot is adjusted, position the SX top pivot bar in the SX hanger such that the gap between the interlock and the hanger is minimal (gap should be less than $\frac{1}{16}$ " for proper function).

204142

Rev. B, 06/13/2017

17 of 31

Figure 19: Swing Out Mechanism

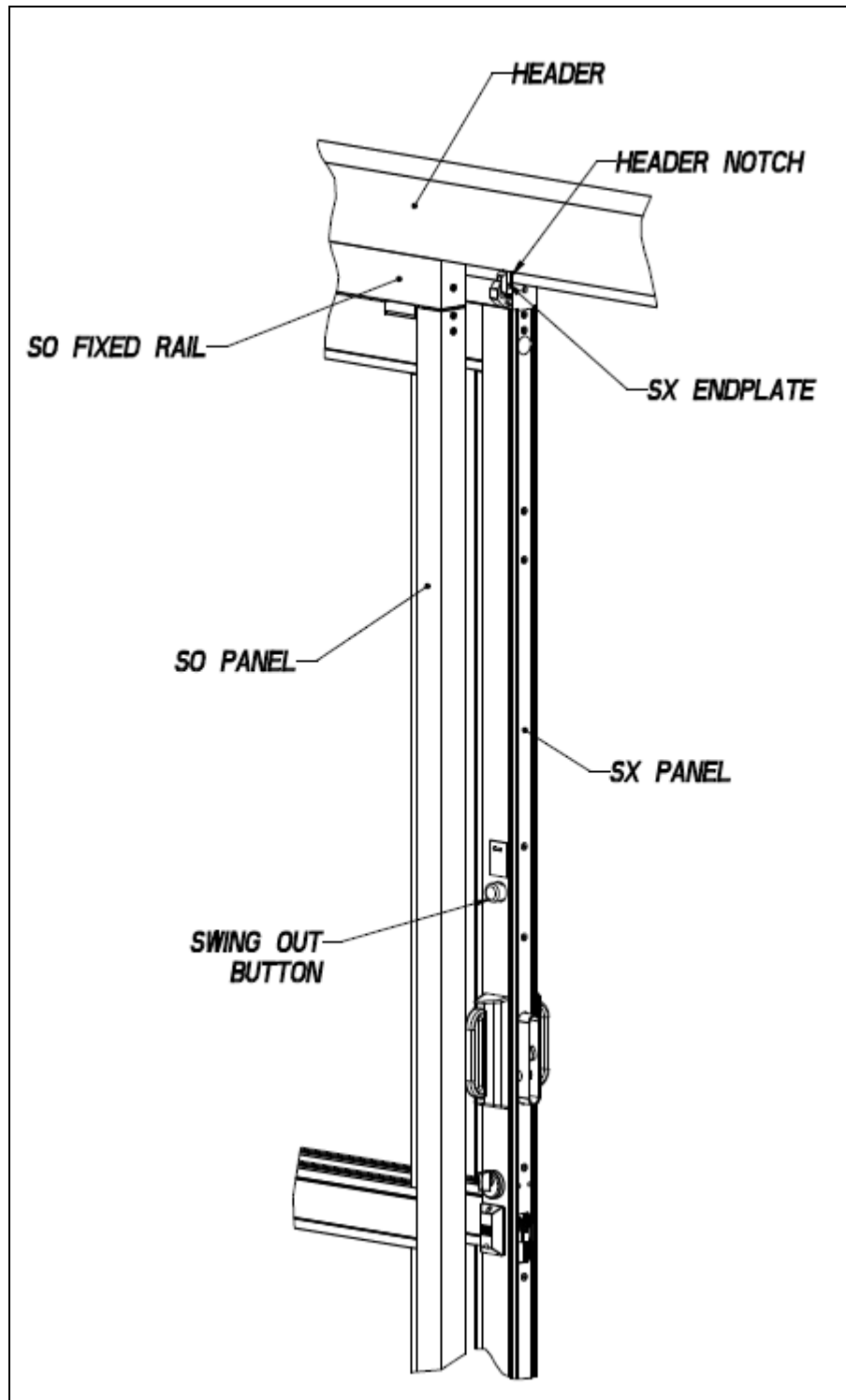

3.8 Installing the Handle Assembly

3.8.1 Refer to Figure 20 and INSTALL the handle assembly.

Figure 20: Installing the Handle Assembly

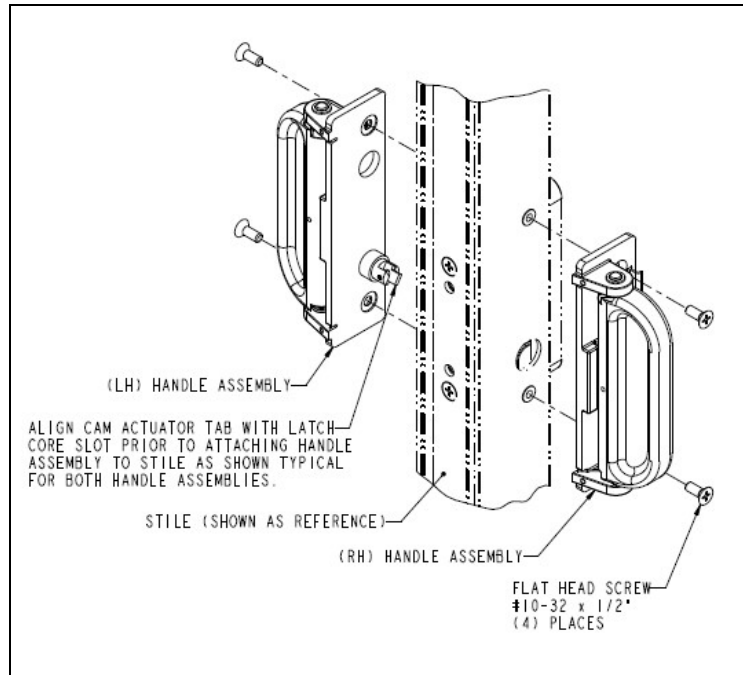

a. The positive latch handles are pre-assembled and handed. Install the handle assemblies using the #10-32 x 1/2" long flathead screws.

3.8.2 For door packages with the positive latch option, ALIGN the cam actuator. The cam actuator is found between the handle assembly and the latch core. The latch core is factory installed. The cam actuator is adjustable to accommodate varying backlash in the latch cores. See Figures 21/22.

Figure 21: Adjusting the Cam Actuator (LH)

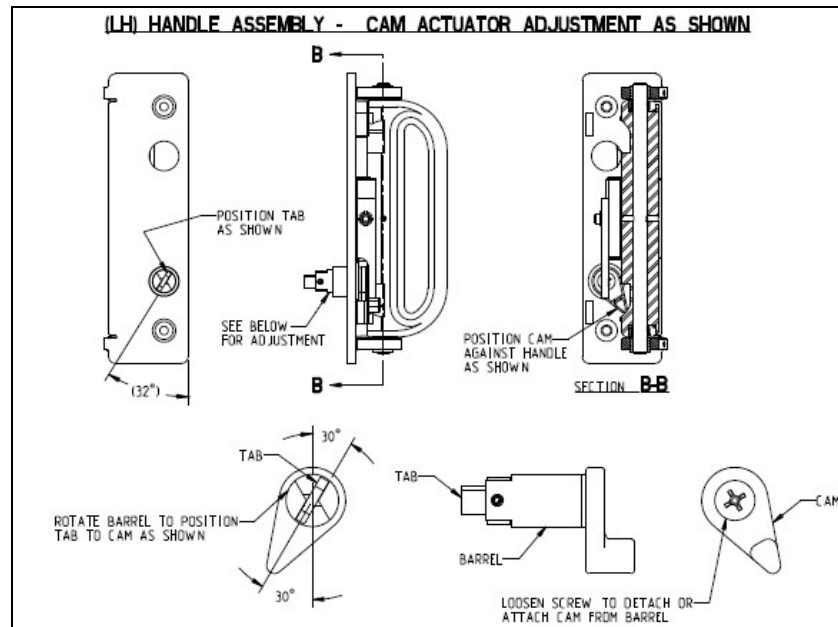

204142

Rev. B, 06/13/2017

19 of 31

Figure 22: Adjusting the Cam Actuator (RH)

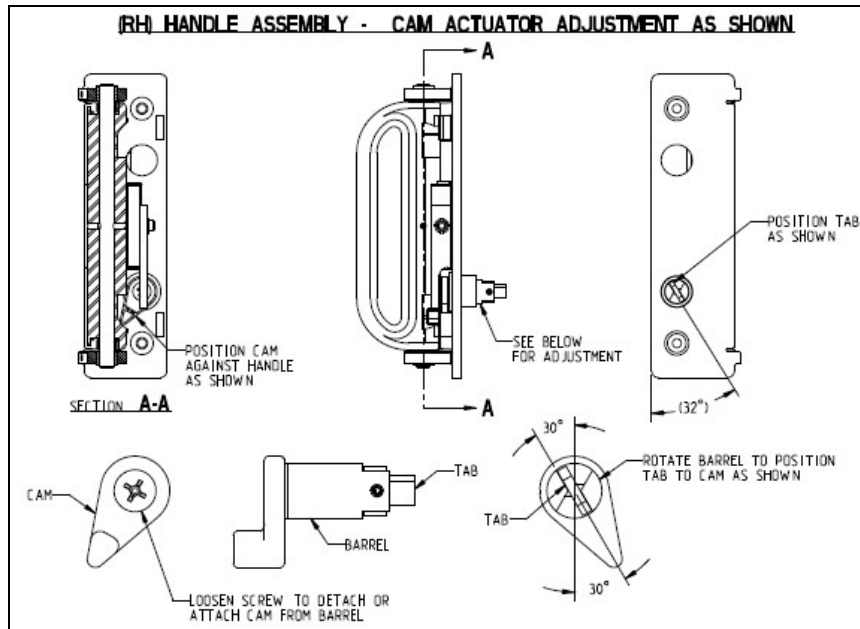

- 3.8.3 Refer to Figure 23 and **INSTALL** the plastic handle cover using the #4-40 flathead screws. Do not overtighten.

Figure 23: Installing the Handle Cover

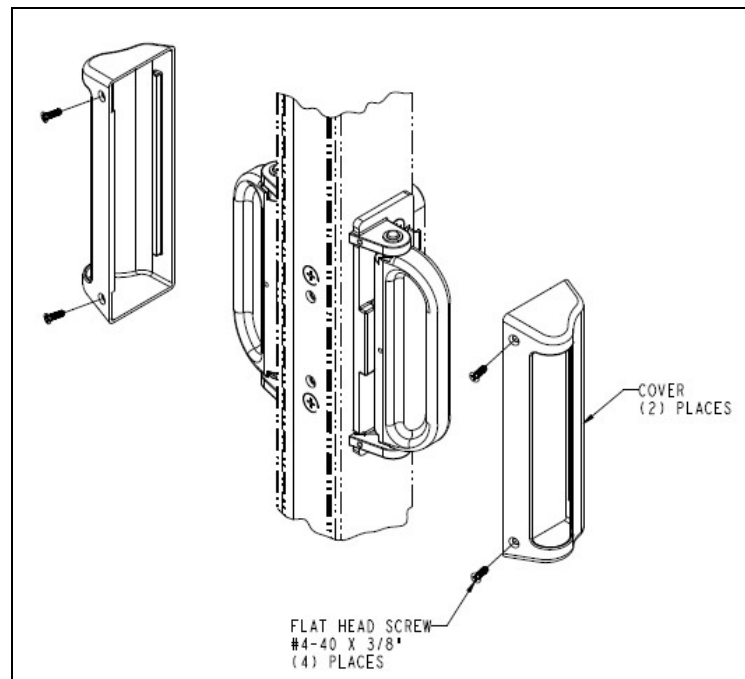

- 3.8.4 For door packages with the positive latch option, **INSTALL** the the jamb strike into the jamb. The jamb strike is intended to absorb the wear from the positive latch and also help reduce noise during normal operation of the positive latch. The positive latch is shipped loose.
- The handle kit contains a jamb strike for both narrow 7/8" wide jambs and also the standard 1-3/4" wide jambs. Select the correct jamb strike from the kit.

204142
Rev. B, 06/13/2017
20 of 31

- b. Fasten the jamb strike using a single screw after the jamb has been installed. Do not overtighten. If worn, the jamb strike can be flipped vertically for further use.

Figure 24: Installing the Jamb Strike

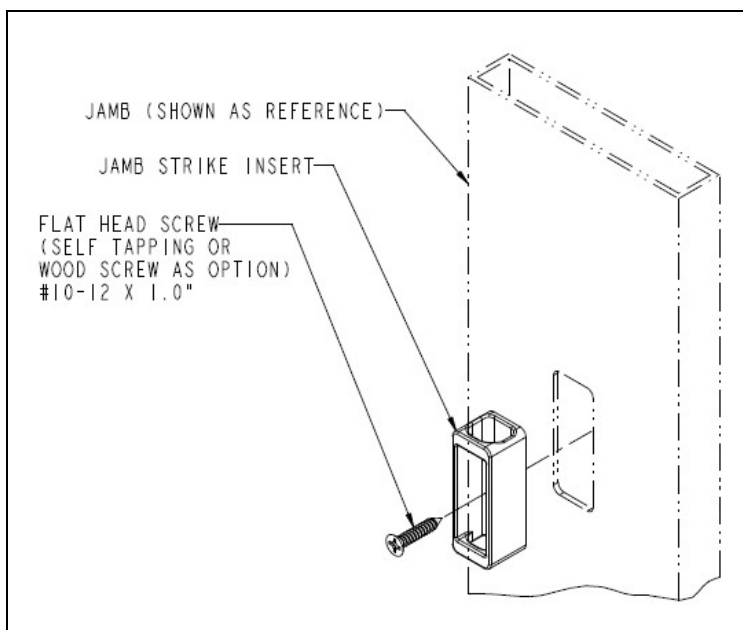

3.9 Installing Self Closer/Damper Kit (Optional)

3.9.1 Refer to [Figure 27](#) for standard closer packages and [Figure 28](#) for dual closer door packages.

- a. For standard single closer installation, perform the the following:
- 1) Remove the two screws from the side of the closer spring unit. Attach the closer attachment bracket and re-install the two screws.
 - 2) Remove the two screws from bottom of closer spring unit based on orientation required for a Right-Hand or Left-Hand door.
 - 3) ATTACH support plate to header using two #8-18 self-tapping screws as shown which are provided in the closer kit (314245).
 - 4) FASTEN spring unit to support plate using the two screws from step 2 above.
 - 5) The closer pulley is factory installed to the hanger.
 - 6) Extend the retractable closer cable from the spring unit, wrap it around the pulley, and hook the loop to the closer attachment bracket.
- b. For dual closer installation, the standard load wheels must be replaced with low-friction load wheels. See section 3.6.5.a. Items for attaching the dual closers can be found within the 314284 hardware kit. For dual closers, perform the following:
- 1) Secure the dual closer plate to a pair of closers using four #4-40 x 3/8" long flathead screws. See Figure 25 below.
 - 2) Attach the dual closer assembly to the header using the #8-32 x 3/8" long flathead screws. For a left-hand package, use the lower countersunk holes to attach the the plate to the header. For a right-hand package use the upper countersunk holes to attach the plate to the header. See Figure 25 below.

204142

Rev. B, 06/13/2017

21 of 31

Figure 25: Attaching the Dual Closer Assembly

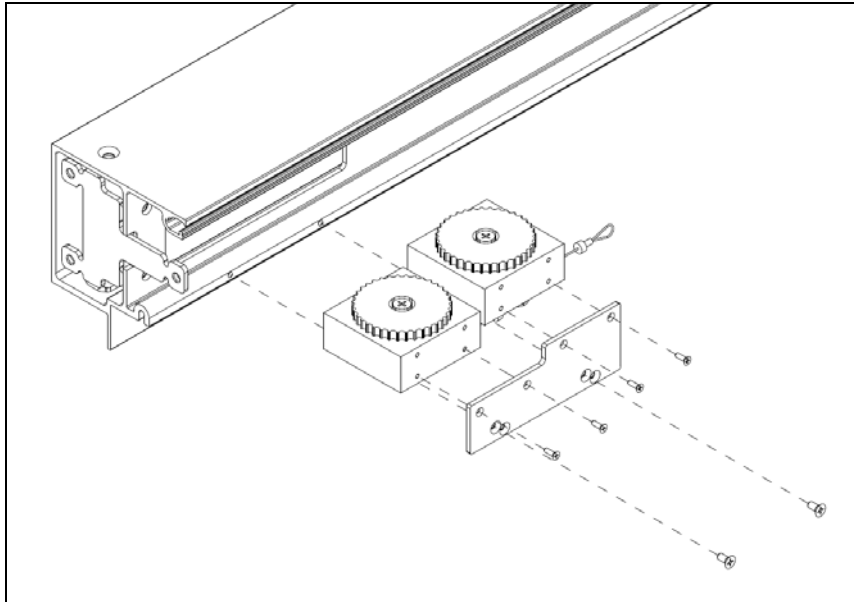

3) Loop and secure the closer cables to the hanger bracket as shown in Figure 26.

Figure 26: Attaching the Cable (Backside: Header Not Shown)

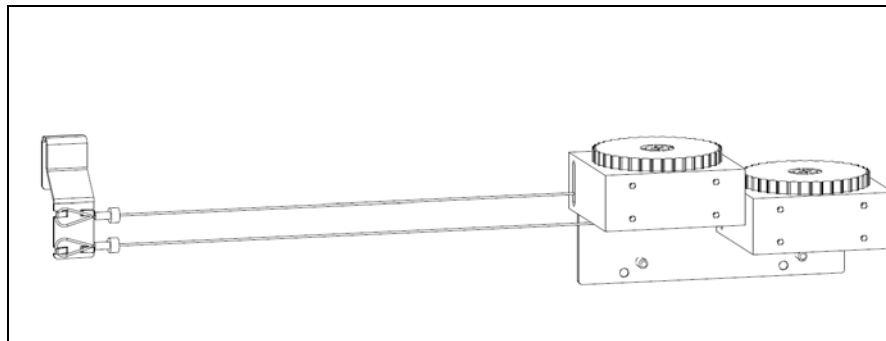

4) Pull the hanger bracket behind the hanger and install a panhead screw through the bracket and into the hanger as shown in Figure 28 below.

Figure 27: Installing the Standard Self-Closer/Damper Kit (Optional)

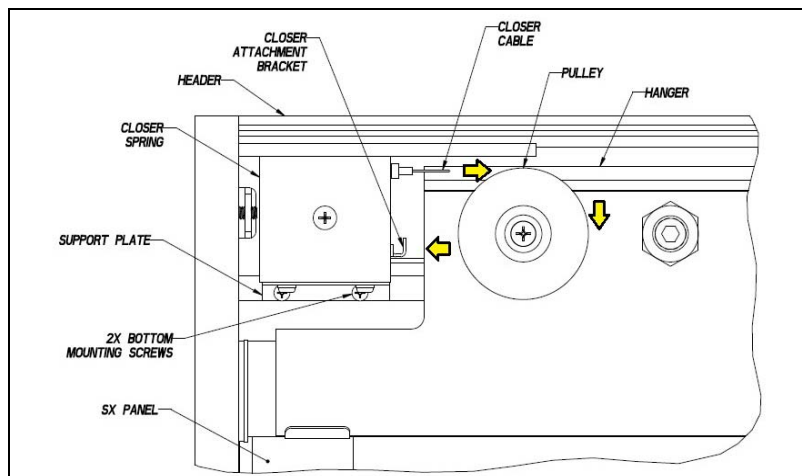

204142

Rev. B, 06/13/2017

22 of 31

NOTE

Adjust closer wire tension as necessary by turning screw on face of spring unit using flathead screwdriver.

Figure 28: Installing the Dual Self-Closer/Damper Kit (Optional)



- 3.9.2 The dampener rack is factory installed into the header at a position of 30" from the lead edge of the jamb. See Figure 29. ENSURE it is in line with the top inside corner of the header extrusion.

Figure 29: Attaching the Rack to the Header

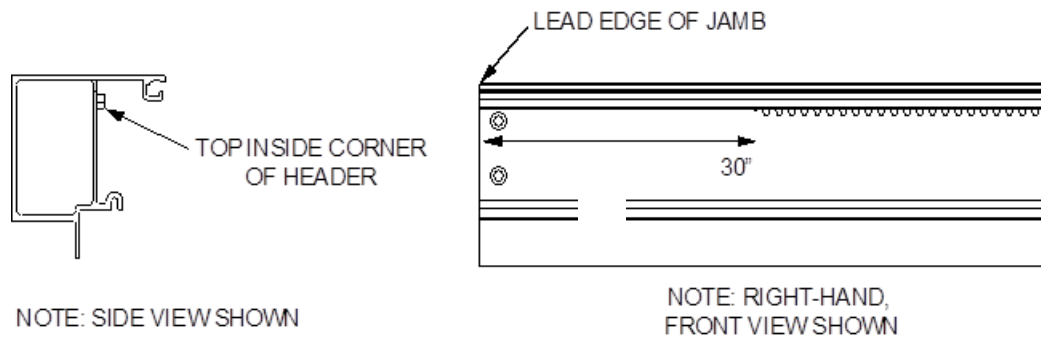

- 3.9.3 Refer to Figure 30 and ATTACH the damper to the hanger, using two #8 screws. Adjust up or down as necessary to ENSURE gear teeth catch the rack.
- a. The #8 hardware & dampener are provided in the Self Closer Kit (314245/314284).

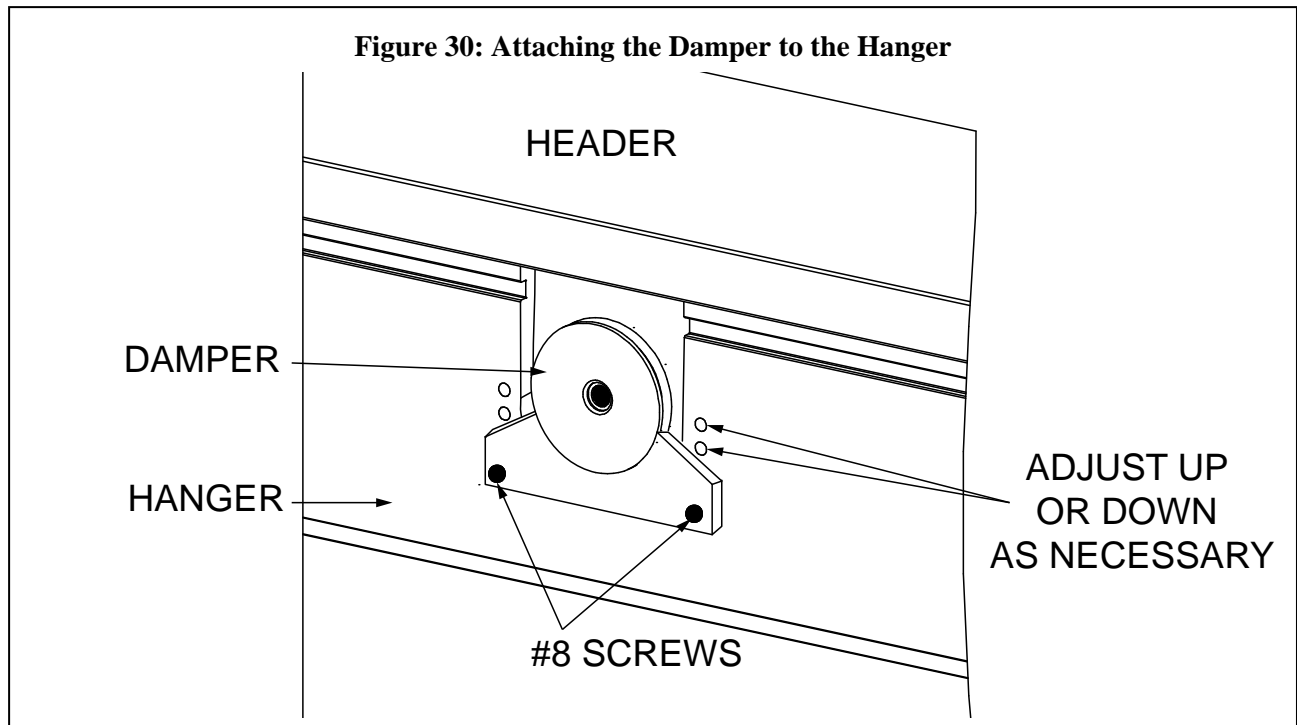

- 3.9.4 Proper installation for the damper clutch is the damper gear should spin easily in the open door direction and have resistance in the close door direction.
- 3.9.5 The damper clutch can be reversed by taking the clip out and reversing the white gear wheel.
- 3.9.6 Dampening amount is adjustable via the small screw in the center of the damper.

3.10 Proper Glass Blocking of Door

- 3.10.1 Partially swing door open and slide a wedge under the lead stile
- 3.10.2 Install outer glass stops (glass stop gutter) with vinyl inserts
- 3.10.3 Position glazing shims

NOTE

For door panels with an intermediate rail, glaze the LOWER section of door FIRST and follow steps 3.10.3 – 3.10.6. After the lower section has been glazed follow the same basic procedures for the upper section.

- a. For door panels WITHOUT intermediate rails, refer to Figure 31 Left and position shims at points #1, #2, & #3
- b. For door panels WITH intermediate rails, refer Figure 31 Right and position shims in the lower section at points #1, #2, & #3

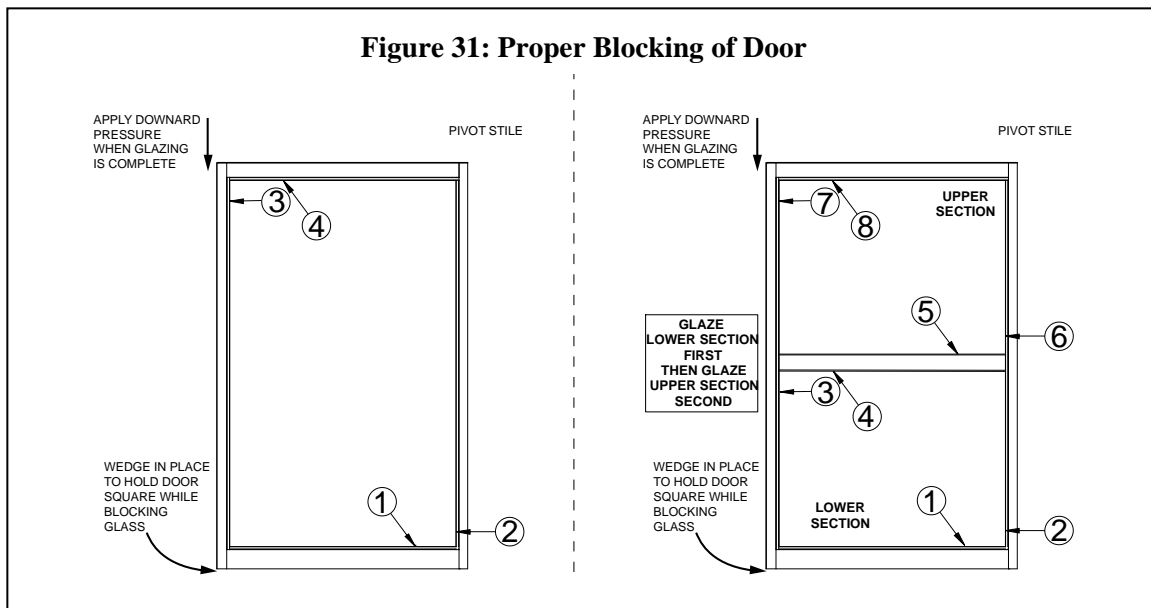

3.10.4 Insert glass panel

- a. Insert glass pane with shims in place
- b. ENSURE margin or gap between the glass edge and aluminum door frame is equal distance at the top, bottom, and two sides
- c. IF margin is unequal, add shims to reference points #1, #2, #3 as shown in Figure 31 to obtain an equal margin

3.10.5 Adjust glazing

- a. Refer to Figure 31 reference point #4 and determine thickness of shim
- b. Drive the wedge further under lead door stile and insert shim

204142

Rev. B, 06/13/2017

25 of 31

REMINDER:

For door panels WITH intermediate rail: REPEAT Sections 3.10.3 – 3.10.6 for the upper section at reference points #5, #6, #7, #8.

The SO panel top rail contains an adjustment screw to fine-tune the door squareness as needed. Ensure a shim is installed at position 4 (Figure 31 Left) or position 8 (Figure 31 Right) so that the adjustment screw will apply pressure to the glass via the shim.

- 3.10.6 Install interior glass stops
 - a. Install interior glass stops with vinyl inserts
 - b. Remove wedge from under lead door stile
 - c. ENSURE door is square in closed position

3.11 Performing the Closeout Procedure

- 3.11.1 ENSURE glass is not cracked or broken.
- 3.11.2 ENSURE glass and metal surfaces are clean.
- 3.11.3 ENSURE door installation area is clean and free of debris.
- 3.11.4 SECURE header cover latch using the No. 10 screw at both ends of the header.

Figure 32: Latching the Cover

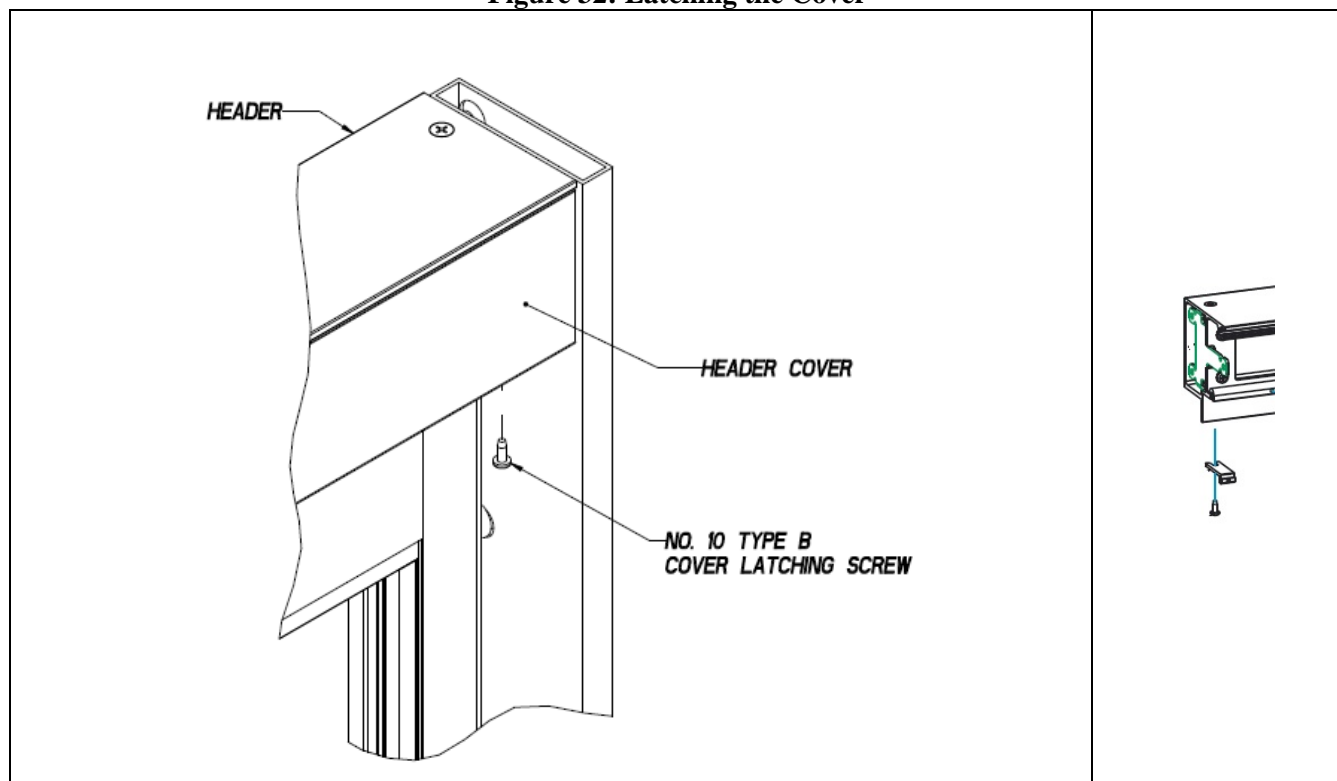

CAUTION

1. Caulk joints of $\frac{1}{4}$ inch are typical. If caulk gap exceeds $\frac{1}{2}$ inch, the Installation Coordinator must be consulted to determine corrective actions.
2. The header cover joint must *never* be caulked.

3.11.5 **IF** required, CAULK the following as specified in door specification, work order, or construction documents:

Top of header, sides of jambs

3.11.6 COMPLETE Work Order and REPORT your actions to Building Superintendent.

3.12 Swing Latch Adjustment

3.12.1 The swing latch force is adjustable and should be set so the door can be swung out without excessive force. The swing latch force should also retract properly without binding and have enough force to return the swing out button.

- a. Swing out the SX door panel to separate the panel from the hanger for access.
- b. Remove the two flathead screws that secure the SX interlock endplate assembly. Slide the SX interlock endplate assembly upwards out of the stile.
- c. Carefully rotate the swing out button counterclockwise using either a $\frac{3}{4}$ " wrench or the flat, bottom pivot wrench. Take care not to scratch or scrape the surface finish.
- d. Remove the four flathead screws that secure the swing latch assembly to the SX stile. Slide the entire swing latch assembly upwards enough to access the jam nuts.
- e. Adjust the top two jam nuts to increase or decrease the activation force. Once adjusted, secure and lock the jam nuts in place.

Figure 33: Removing the Swing Latch

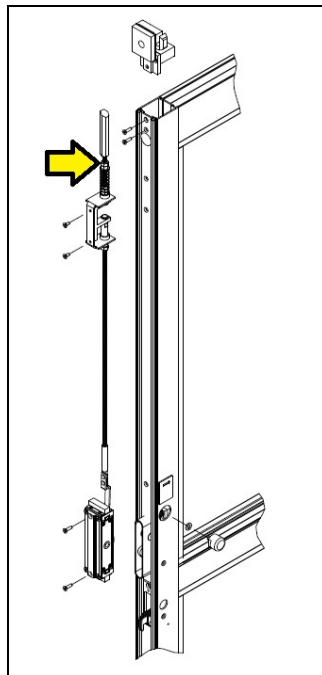

- f. Reverse removal instructions to re-install. Install swing button with lock washer.

Attachment 1
Documents, Definitions, Tools, Equipment, Materials, and Consumables
(Sheet 1 of 1)

Documents

- Manufacturer's instructions for latch and lock installation.

Definitions

- None

Tools and Equipment (including, but not limited to)

- Caulking Gun
- Combination Square
- Concrete Drill Bits
- Electric Drill
- Metal Drill Bit Set
- Saw Horses (with protected working surface)
- Basic Hand Tool
- Bottom Pivot Adj. Wrench – Stanley P/N: 415080
- Tape Measure
- *12-Point 3/8" Socket

*The 12-Point socket is used to secure the SX top rail tie-rod nut. This 12-point nut should be torqued to 168 in-lbs (+/- 6 in-lbs) non-lubricated.

Materials (including, but not limited to)

- Concrete Expansion Shields
- Glass Panels
- ICU Smoke & Draft Kit (See Below)
- Lag Bolts

Consumables (including, but not limited to)

- Clean Rags
- Glass Cleaner or Isopropyl Alcohol
- Silicone Caulk

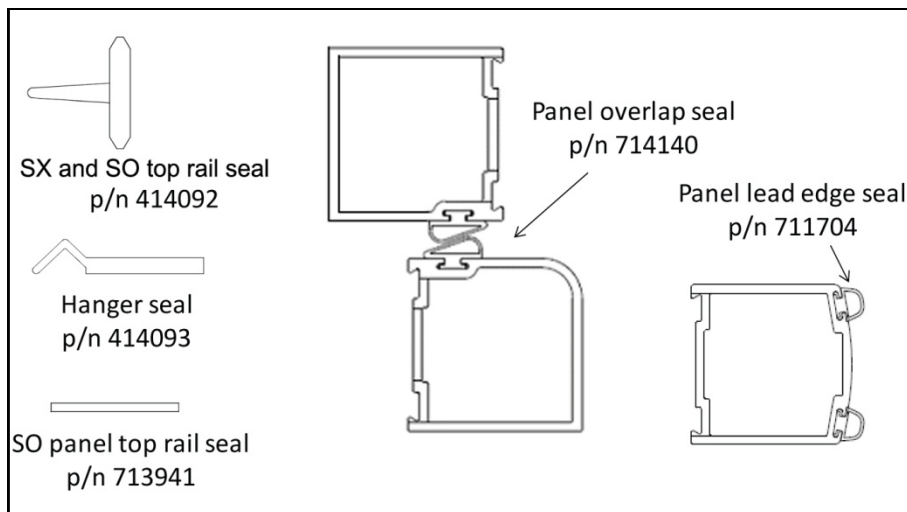

204142
Rev. B, 06/13/2017
28 of 31

Attachment 2
Replacement Parts
 (Sheet 1 of 3)

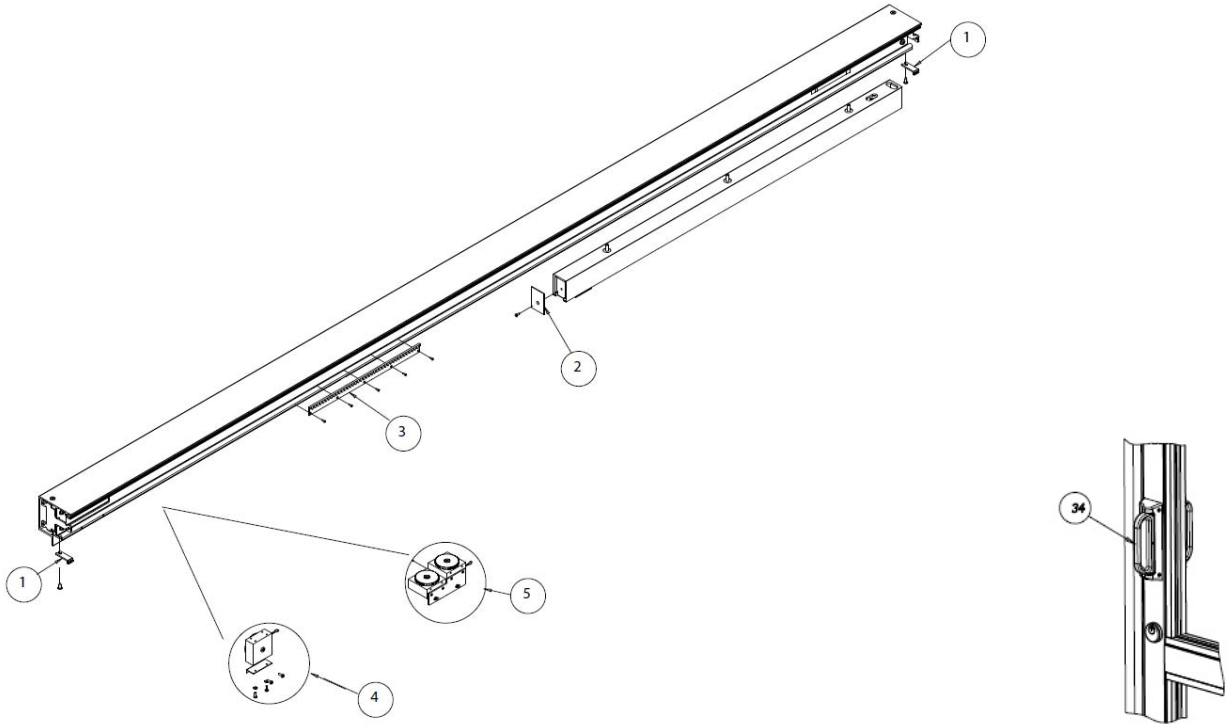

SO Panel Shown

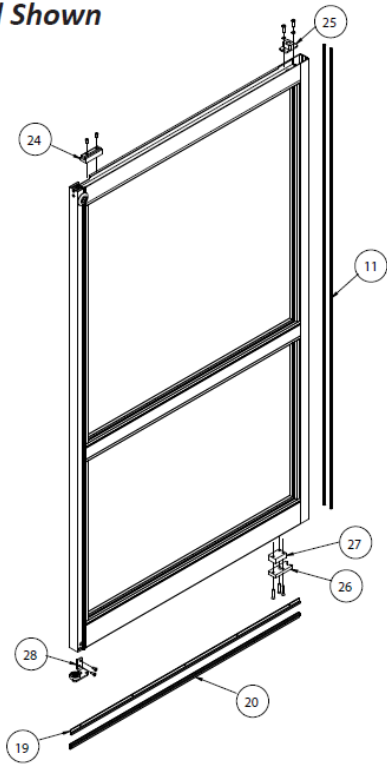

SX Panel Shown

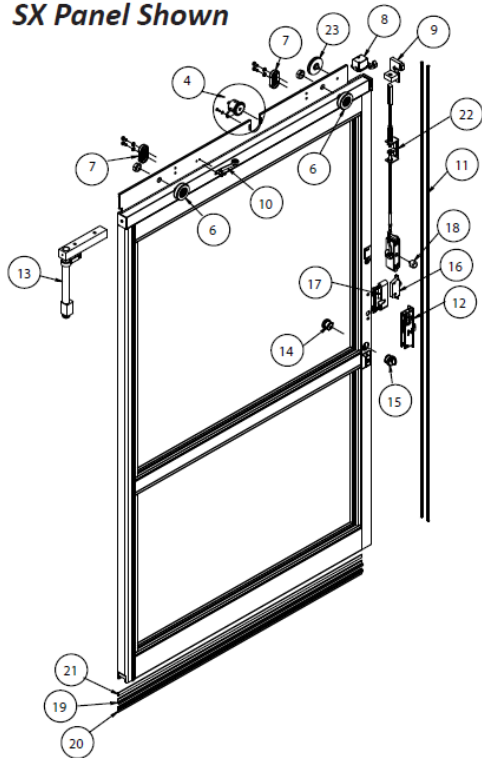

**Attachment 2
Replacement Parts**
(Sheet 2 of 3)

Item	Stanley P/N	Description	Qty. Per Pkg.
001	417836-1	Latch, ICU Cover (Clr)	2
	417836-2	Latch, ICU Cover (Drk Brz)	
	417836-3	Latch, ICU Cover (Mill)	
002	417198	End Cap, SO Fixed Rail	2
003	417597	Rack, Dampener Option	1
004	314245	Kit, Self Closer	1
005	314284	Kit, ICU Dual Closer	1
006	*411499	Wheel Assy-Load	2
007	417845	Anti-Riser	2
008	517802-1	Assy, Swing Interlock –LH	1
	517802-2	Assy, Swing Interlock –RH	
009	517803-1	Assy, Interlock Endplate – LH (Clr)	1
	547803-1	Assy, Interlock Endplate –LH (Drk Brz)	
	517803-2	Assy, Interlock Endplate – RH (Clr)	
	547803-2	Assy, Interlock Endplate –RH (Drk Brz)	
010	417876	Assy, ESD Gnd Wheel	1
011	711704	Weatherstrip, ICU Vinyl, Black	Per Foot
012	515258	Lock – 1 Point	1
013	515700-2	Pivot, SX Assy	1
014	706668	Cylinder – Lock	1
	709648	Cylinder – Lock – Black	
	710625	Lock Cyl – Keyed Alike – Black	
	710632	Lock Cyl – Keyed Alike – Clear	
	713763	Cylinder – Schlage Lock	
	713832-1	Lock – Constr – Core/Key (Clr)	
	713832-2	Lock – Constr – Core/Key (Drk Brz)	
	713845-1	Cylinder – Dummy (Clear)	
713845-2	Cylinder – Dummy (Drk Brz)		
015	709221	Thumbturn - Lock	1
	709647	Thumbturn – Lock – Black	
016	700495	Hook, Positive Latch	1
017	517814	Assy, Pos. Latch Retractable Hook Shield	1
018	417907-1	Button, ICU Swing Out (Clr)	1
	417907-2	Button, ICU Swing Out (Drk Brz)	
	417907-3	Button, ICU Swing Out (Clr Anti-Micro.)	
	417907-4	Button, ICU Swing Out (Drk Brz Anti-Micro.)	
019	417199-12000	Holder, Sweep Machining	Per Foot
020	417201	Gasket, Sweep	Per Foot
021	700209	Tape, VHBM -1/2"	Per Foot

204142
Rev. B, 06/13/2017
30 of 31

Item	Stanley P/N	Description	Qty. Per Pkg.
022	1000452-1	Assy, Swing Out Auto Latch –LH	1
	1000452-2	Assy, Swing Out Auto Latch -RH	
023	417912	Assy, Cable Pulley	1
024	417906	SO Door Portion Detent	1
025	417291	Pivot, Block Top	1
026	410895	Pivot, Bot. Door Portion (SO)	1
027	417430	Spacer, SO Pivot	1
028	314126-1	Kit, Bottom Guide Assy -LH	1
	314127-1	Kit, Bottom Guide Assy -RH	
029	314128-1	Kit, Weatherstrip & Seal	1
030	314129	Kit, ICU Smoke & Draft	1
031	314237	Kit, Hold Open	1
	344237	Kit, Hold Open –Drk Brz	
032	314281	Kit, ICU Jamb Mounting (Clr)	1
	344281	Kit, ICU Jamb Mounting (Drk Brz)	
033	314285	Kit, 2-Panel ICU Hardware	1
034	314283-1	Kit, ICU Handle Assy (Clr)	1
	314283-2	Kit, ICU Handle Assy (Drk Brz)	
	314283-3	Kit, ICU Handle Assy (Clr Anti-Micro.)	
	314283-4	Kit, ICU Handle Assy (Drk Brz Anti-Micro.)	

**For door packages with self-closer option that are greater than 8' wide or have glass greater than 1/4" thick, replace load wheels with special low-friction load wheels (Stanley P/N: 412872) which are found in the dual closer kit (Item 005 - Stanley P/N: 314284)*

204142
Rev. B, 06/13/2017
31 of 31