

## TECH TIP

# MC521 PRO CONTROLLER SLIDE DOOR Installation and Operation Manual

Prepared by: Jeff Bonas

Engineer: Tony Ranaudo, Len Pursell

Tech Tip: TT170727

CN: \_\_\_\_\_

RDW: \_\_\_\_\_

Reference Tech Tip: \_\_\_\_\_

Engineering Document Number: \_\_\_\_\_

### Summary Information

#### Product Information

- |   |                                  |  |   |   |
|---|----------------------------------|--|---|---|
| <input type="checkbox"/> Bifold           | <input type="checkbox"/> Swing   | <input type="checkbox"/> Accessories         | <input type="checkbox"/> Operators / Drives | <input checked="" type="checkbox"/> Sensors |
| <input checked="" type="checkbox"/> Slide | <input type="checkbox"/> Class 2 | <input checked="" type="checkbox"/> Controls | <input type="checkbox"/> Panels / Hardware  |   |

#### Tech Tip Classification

- |  |  |                                  |  |
|--|--|----------------------------------|--|
| <input type="checkbox"/> Adjustment              | <input type="checkbox"/> Customer Complaints | <input type="checkbox"/> FAQs    | <input type="checkbox"/> Retrofit/Upgrade Instructions |
| <input checked="" type="checkbox"/> Installation | <input type="checkbox"/> Clarifications      | <input type="checkbox"/> Service | <input type="checkbox"/> Design Change Description     |

#### Release Action

- Level 1 - Does not impact maintenance or operation of door. (Only Safety/Liability and Engineering need to sign.)
- Level 2 - Full sign off required.

#### Release Information (initial and date)

Safety/Liability \_\_\_\_\_

Engineering \_\_\_\_\_

Technical Support \_\_\_\_\_

Field Operations \_\_\_\_\_

Quality \_\_\_\_\_

If you have any questions concerning this procedure, contact

Access Technologies Technical Support, at 1-800-422-6489 Option 3.

# MC521 PRO CONTROLLER SLIDE DOOR Installation and Operation Manual

Attached is the revised MC521 Pro Controller Manual:

- MC521 Pro Controller Installation and Operation Manual (204066) Rev. F, for automatic sliding doors)

Included in the revised manuals are the following:

- Settings for Monitored Presence Sensors
- Updated Wiring Diagrams including monitored presence sensors
- Android MC521 Toolbox Troubleshooting enhancements for monitored presence sensors
- Android MC521 Toolbox Troubleshooting Output Control Mode

If you have any questions concerning this procedure, contact

Access Technologies Technical Support, at 1-800-422-6489 Option 3.

**MC521 Pro Controller  
Installation and Operation Manual  
204066**

**INCLUDES INSTRUCTIONS FOR**

**DURA-GLIDE™ 2000/3000, 5200/5300,  
DURA-GUARD™ DURA-STORM™ AND DURA-MAX™ 5400-SERIES  
AUTOMATIC SLIDE DOOR SYSTEMS**

Stanley Part Number 204066

REV F 12.2016

*Copyright 2016, Stanley Access Technologies, LLC.*

*Prohibition on Copying: Any unauthorized reproduction, disclosure or distribution of copies by any person of any portion of this work may be a violation of copyright law of the United States of America and other countries, could result in the awarding of statutory damages of up to \$250,000 (17 USC 504) for infringement, and may result in further civil and criminal penalties. All rights reserved.*

# Table of Contents

<b>General Description .....</b>	<b>2</b>
Intended Use .....	2
Applicability .....	2
Prerequisites .....	3
Precautions .....	3
<b>Installation Instructions .....</b>	<b>3</b>
Installing the MC521 Pro Controller .....	3
<b>Wiring Instructions .....</b>	<b>3</b>
Evaluating Power Requirements .....	3
Connecting Main Power Wiring .....	4
Connecting Accessories (As Applicable).....	4
<b>Tune-In Instructions.....</b>	<b>4</b>
Tuning In the MC521 Pro Controller Using a Handheld Device .....	5
Tuning In the MC521 Pro Controller Using Pushbuttons .....	9
Final Tune-In Adjustments .....	13
<b>Spare Parts List.....</b>	<b>14</b>
<b>Attachments .....</b>	<b>15</b>
Attachment 1 - MC521 Pro Controls and Indicators .....	15
Attachment 2 - MC521 Pro System Wiring Diagram .....	17
Attachment 3 - MC521 Pro Terminal Block Connections TB1-TB7 .....	28
Attachment 4 - ANSI/BHMA and UL Compliance Requirements for Sliding Doors ..	29
Attachment 5 - Handheld Device Troubleshooting Aid .....	31
Attachment 6 - Handheld Device Troubleshooting Screen Descriptions .....	32
Attachment 7 - MC521 Pro Troubleshooting Aid .....	34
Attachment 8 - Recommended Values for Different/Weights Types of Slide Door ..	35
Attachment 9 - Fine Tuning Slide Doors .....	36

---

## 1 GENERAL DESCRIPTION

### Intended Use

This manual provides installation instructions, wiring instructions, and tune-in instructions for the MC521 Pro Controller. It includes instructions for Dura-Glide™ 2000/3000, 5200/5300, Dura-Guard™, Dura-Storm™, and Dura-Max™ 5400-Series, Automatic Slide door systems.

On Dura-Glide sliding doors, the MC521 Pro Controller replaces the MC521 or both the microprocessor control box and the interface board on older models. The door activation devices (SU-100 motion sensors, carpets, push plates, etc.), lock, function switch, doorway holding beams, and door position switches previously connected to the interface board must be connected to the MC521 Pro Controller.

Attachment 1 illustrates the MC521 Pro Controller controls and indicators. Attachment 2 illustrates system wiring for Dura-Glide series sliders.

### Applicability

This manual is applicable to the Dura-Glide series sliding doors used on Dura-Glide™ 2000/3000, 5200/5300, Dura-Guard™, Dura-Storm™, and Dura-Max™ 5400-Series, Automatic Slide door systems. Instructions for connecting optional accessories are not provided in this manual.

## Prerequisites

---

### Special Items Required:

- Stanley Access Technologies document No. 203957, “SU-100 Motion Sensor Installation and Operation” (if installed).
- SU-100 tune-in remote control (if SU-100 Motion Sensor is installed).
- Stanley Access Technologies document No. 203768, “Stanguard™ Threshold Sensor Installation and Operation” (if installed).
- Optex X Zone T or X Zone ST manufacturer’s installation and tune-in instructions (if installed).
- Hotron HR100 ST manufacturer’s installation and tune-in instructions (if installed).
- For a list of compatible handheld devices; visit: <http://www.stanleyaccess.com>  
Select **Door Service** > **Technician Mobile Downloads** > **Android Apps**. Select Compatible Handheld Devices Document.
- Bluetooth adapter or cable to connect compatible handheld device to MC521 Pro Controller.
- Degreaser.
- Instructions for any other device to be wired into the MC521 Pro Controller.

## Precautions

---

All ANSI/BHMA and UL Requirements in Attachment 4 must be met before the door is put into operation.

## 2 INSTALLATION INSTRUCTIONS

### Installing the MC521 Pro Controller

---

**NOTE:** This manual covers new door installations in which the MC521 Pro is factory-installed and wired.

## 3 WIRING INSTRUCTIONS

### Evaluating Power Requirements

---

- ENSURE power source is a dedicated 115 VAC, 50/60 Hz source with 20A circuit rating. If four operators are used, the source should have a 30A rating.
- ENSURE **no more than** four operators will be connected to one circuit.
- ENSURE power source is **not** shared with other equipment, i.e., cash registers, EAS systems, or other electromagnetic interference generators.

## Connecting Main Power Wiring

**⚠ Warning:** To prevent injury to personnel, incoming electrical power to the header must be deenergized before connecting electrical service to the control box.

**⚠ Warning:** All electrical wiring must conform to National Electrical Code Requirements.

1. **DEENERGIZE** incoming electrical power to header.
2. Refer to Attachment 2, and, using wire nuts, **CONNECT** incoming line, neutral, and ground wires to the controller power harness.
3. IF adhesive wire clamps will be used, **DEGREASE** metal surfaces on inside of header cover where clamps will mount.
4. **SECURE** wiring to top of the header track tube, and **ENSURE** the following:
  - All wires are clear of belts and belt brackets.
  - Header cover opens and closes without interference.

## Connecting Accessories (As Applicable)

Refer to Attachments 2 and 3, and **CONNECT** any of the following subsystems to the MC521 Pro Controller:

- Function switch (rotary, rocker and “POWER” switch wiring).
- Stanguard™ threshold sensor.
- Doorway holding beam(s).
- Breakout switch.
- Solenoid lock.
- SU-100 motion sensor(s) wiring (refer to Stanley Document #203957).
- Optex X Zone T and X Zone ST Sensor(s) wiring.
- Push plate wiring.
- Door position switch closed contact (with door closed).
- Hotron HR100 ST Sensor(s) wiring.

## 4 TUNE-IN INSTRUCTIONS

**⚠ Warning:** The door path must be free of objects and remain clear until the First Install Sequence (FIS) is complete. During this sequence the sensors are inactive and the door has no SAFETY. To stop the door, **turn power off** or put the **doors into breakout**.

### NOTE:

1. **Tune In:** The MC521 Pro Controller can be tuned-in using a handheld device or using the pushbutton switches located on the controller. Tune-in using a handheld device is the preferred method.
2. **Status Codes:** During normal operation, the digital display indicates status codes. The “UP” and “DOWN” pushbutton switches can be used to enter and display data values. The user interface values are shown in Tables 2 through 4.

- Solenoid Lock:** If a solenoid lock is installed with no lock circuit board (new style), set Lock Logic to the actual lock type (Fail Safe or Fail Secure). If a Fail Safe or Fail Secure Lock is being installed with a lock circuit board (old style), the Lock Logic must be set to Fail Secure.
- Handing:** Manually open door noting rotation of belt pulleys. If counter clockwise (CCW) use right hand during FIS. If clockwise (CW) use left hand during FIS. See figure below.
- FIS:** The first installation sequence (FIS) is used to perform the initial configuration. Upon completion of FIS, all setup parameters are stored in non-volatile memory. Subsequent power cycles will reload the configuration parameters that were configured during FIS.
- Decimal points on digital display are encoder 1 signals.
- After changing values, the values must be saved in EEPROM by cycling the door to full open.

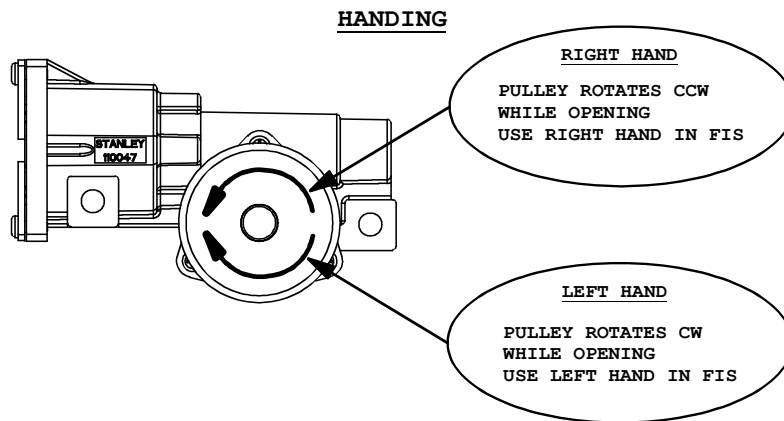

## Tuning In the MC521 Pro Controller Using a Handheld Device

**NOTE:** The following steps provide instructions for tuning the MC521 Pro Controller using a handheld device. MC521 application software is required. Connect the handheld device to the MC521 Pro Controller, turn on header POWER switch, and perform the following steps.

**Step 1:** Select **MC521 Toolbox** from the list of applications.

**Step 2:** Select **RESTART FIS** on the Main selection menu. (FIS = First Install Sequence).

**NOTE:** Firmware is the software revision. Cycles are door cycles in memory.

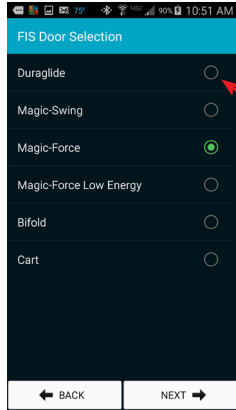

**Step 3:** Select Duraglide.

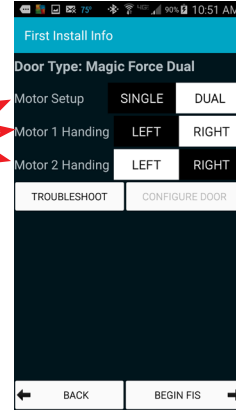

**Step 4:** Select applicable Switch Type, Motor Setup, and Motor Handing.

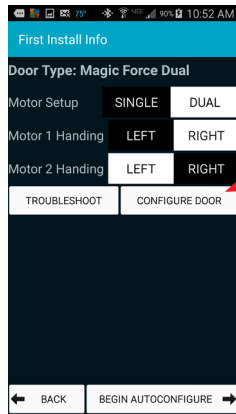

**Step 5:** If additional configuration is needed, press **CONFIGURE DOOR**.

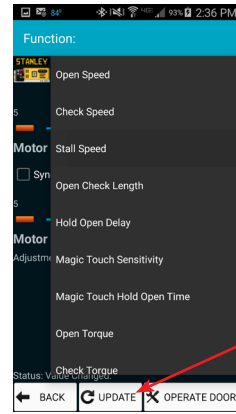

**Step 6:** Configure additional settings and press **UPDATE** after each setting has been changed. Once completed, press **BACK** to go back to the Main selection menu.

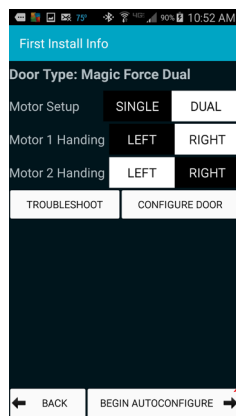

**Step 7:** Press **BEGIN AUTOCONFIGURE**.

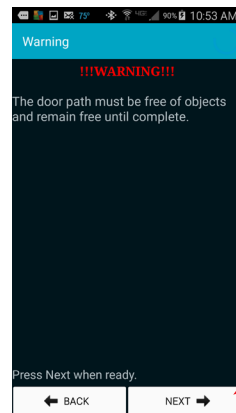

**Step 8:** Press **NEXT**.



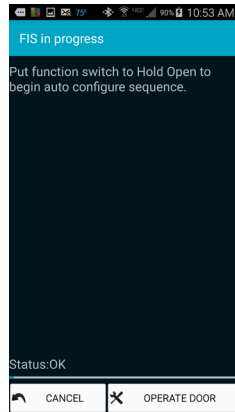

**Step 9:** Put door function switch to **Hold Open** then immediately back to **Closed**. The same function can be done remotely from the Handheld by pressing **Operate**.

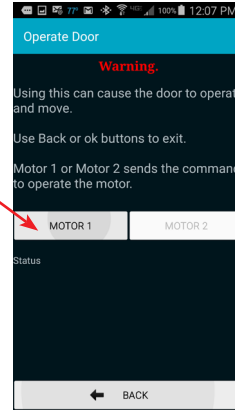

**Step 10:** For all doors except cart doors press **MOTOR 1** to operate and have door(s) move. For cart doors, press **MOTOR 2** when configuring the second door.

**\*\*After performing Step 9 or 10, the door opens fully, delays and then closes fully. The MC521 Pro displays 00 when FIS is completed.\*\***

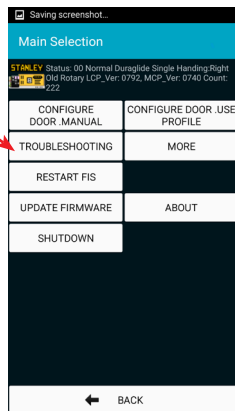

**Step 11:** If the door is not operating correctly select **TROUBLESHOOTING** to enter the Troubleshooting menu.

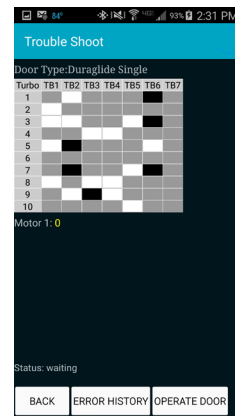

**Step 12:** View the I/O grid to verify the sensors and inputs. Dark indicates input/output contact is closed. Light indicates input/output contact is open. Gray never changes.

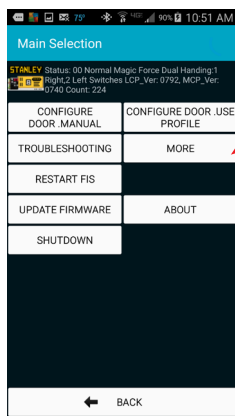

**Step 13:** Press **MORE** to access more functions.

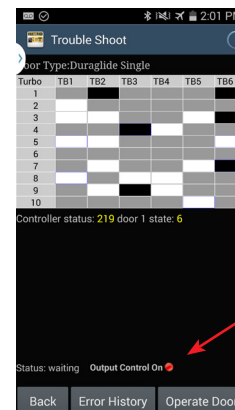

**Step 14:** **Output Control On** displayed. See Attachment 6 for more information.

15

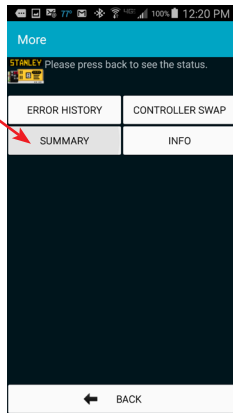

**Step 15:** Press **Summary** to view all current settings.

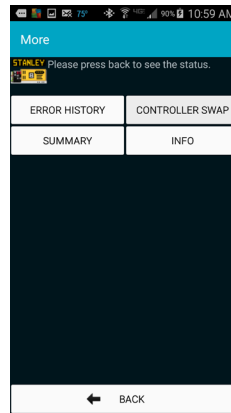

**Step 16:** Review the information on the **Summary** listing.

17

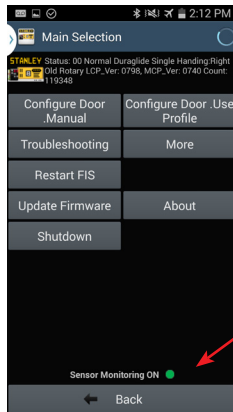

**Step 17:** **Sensor Monitoring On** displayed when configured for monitored sensors.

## Tuning In the MC521 Pro Controller Using the Controller Pushbuttons

---

### NOTE:

1. To change the **INDEX**:  
Hold **ENTER** switch while pressing **UP** or **DOWN** to get to desired **INDEX**.
2. To change a **VALUE**:  
Unlock the keypad by setting index 99 to value 00.  
After the desired **INDEX** is selected, release ENTER and **within 2.5 seconds** press **UP** or **DOWN** to get the desired **VALUE**. (If the **UP** or **DOWN** buttons are not pressed within 2.5 seconds of releasing the **ENTER** button, the display will change from the **VALUE** back to the **STATUS**.)
3. To display **STATUS CODE**:  
A few seconds after the **VALUE** is selected, the display indicates the **STATUS CODE**.
4. To show the **INDEX** and **VALUE**.  
To show the **INDEX**, hold **ENTER**. Once **ENTER** is released the display will show the **VALUE** of that **INDEX**.
5. Read the descriptions entirely before performing each step. Check the **INDEX** and **VALUE** after each step.
6. To **STORE CHANGES** in permanent memory:  
Cycling door open one time will store changes.
7. To **LOCK** keypad:  
Lock keypad by setting index **99** to value **01** or by turning power **OFF** and then **ON**.
8. To **ACCESS** the door cycle counter function:
  - a. **Ensure** that the keypad is locked by setting index 99 to 01.
  - b. **Ensure** that the index is set to any index but 99.
  - c. **Press** the up or down key to access the door cycle counter.  
The display will show "**dc**" followed by four pairs of digits, followed by "**dc**".  
**Example:** If the Door count was **12345678** cycles the controller will display "**dc**" "**12**" "**34**" "**56**" "**78**" "**dc**".

**Table 1. FIS Procedure using Pushbuttons**

Step	Description	Display		
		Index	Value	Status Code
1	Set Function switch to <b>Closed</b> .			
2	Turn power on.			
3	Unlock keypad.	99	00	00
4	Restart <b>FIS</b> .	96	01	A0
5	Select door type: Slide, <u>01</u> single motor or <u>02</u> dual motor.	00	01 (single) 02 (dual)	
6	Select handing: <u>00</u> Right or <u>01</u> Left. <b>Manually open door and note rotation of belt pulleys.</b> <b>If counterclockwise (CCW) use right hand during FIS.</b> <b>If clockwise (CW) use left hand during FIS.</b>	01	00 (right) 01 (left)	A0
7	Accept <b>FIS</b> . Display will go to <b>A1</b> .	03	01	A1
8	Make changes: Function switch <u>01</u> Rocker or <u>00</u> Rotary. The INDEX will start at 00.	11	01 (Rocker) 00 (Rotary)	A1
9	<b>Select Lock Logic:</b> Lock Logic, <u>00</u> = Fail Safe; <u>01</u> = Fail Secure. <b>NOTE:</b> For locks with circuit board, set to 01 Fail Secure. For locks with no circuit board, set to Fail Safe or Fail Secure.	07	00 (Fail Safe) 01 (Fail Secure)	
10	<b>⚠ Warning:</b> During this sequence the sensors are inactive and the door has <b>NO SAFETY</b> . To stop the door, <b>TURN POWER OFF</b> or <b>PUT THE DOOR INTO BREAKOUT</b> . <b>Function Switch:</b> Switch to <b>OPEN</b> , momentarily, then <b>CLOSED/ LOCKED</b> . The door opens fully, delays and then closes fully. The MC521 Pro displays A2 when FIS is completed.			A2
11	Lock keypad.	99	01	00
12	Final Tune in.			

**Table 2. Index List**

Index	Description
00-89	Settings Values, see Table 3.
90-95	Reserved.
96	Command – Restart FIS. Entering “01” will cause FIS to restart.
97	Firmware – Entering “01” will display “FE” followed by two pairs of digits followed by “FE”. For example, if the firmware was 0609 the controller will display “FE” “06” “09” “FE”.
98	Command – Restart auto configuration. Entering “01” will cause auto configuration.
99	Command – Lock. Entering “01” will lock all value inputs except this index. This prevents inadvertent changes to input values. Values may be unlocked by entering “00” in this index.

**Index 98 sets the Control Box to “A1” keeping all previous values and then relearns the encoder count.**

**Table 3. Settings**

Index	Min. Value	Max Value	Description	Defaults	
				Single	Dual
00	05	35	Open speed, increment by 1.	25	25
01	05	18	Close speed, revolutions per second.	12	12
02	03	10	Check speed, revolutions per second.	04	04
03	10	99	Open check length.	35	35
04	10	99	Close check length.	30	30
05	00	99	Reduced open position, percent of full opening (00=full open, 99=full close).	01	01
06	01	99	Hold open delay (0 to 25 sec.).	06	06
07	00	03	Lock Logic, 00 = Fail Safe, 01 = Fail Secure, 02 = Dura-Max Fail Safe, 03 = Dura-Max Fail Secure. <b>NOTE:</b> For locks with circuit board, set to 01 Fail Secure. For locks with no circuit board, set to Fail Safe or Fail Secure.	01	01
08	05	75	Open torque, percent of full scale.	25	40
09	00	75	Close torque, percent of full scale.	25	15
10	00	75	Check torque, percent of full scale.	25	10
11	00	01	Dura-Glide function switch type: 00=double pole rotary, 01=rocker.	01	01
12	00	01	2S Operation, 0=off, 1=on.	00	00
13	01	60	Obstruction Time Delay (.01 – 1.5 sec).	20	40
14	20	60	Open Acceleration, (larger value=faster acceleration).	60	60
15	20	60	Open Braking, (larger value=increased braking). 20=No open braking.	54	54
16	20	60	Close Acceleration, (larger value=faster acceleration).	20	20
17	20	60	Close Braking, (larger value=increased braking). 20=No close braking.	40	40
18	00	02	00 = Off (Delay Egress), 01 = 15 sec. delay, 02 = 30 sec. delay.	00	00
19*	00	05	00 - Monitored 2 Sensors - Threshold Zone Control (The threshold zone is enabled and disabled by the MC521 Pro). 01 - Monitored 4 Sensors - Threshold Zone Control (The threshold zone is enabled and disabled by the MC521 Pro). 02 - Monitored StanGuard™(not recommended for Telescopic Doors). 03 - Monitored 2 Sensors. 04 - Non-Monitored Sensors. 05 - Monitored 4 Sensors.	02	02
20	00	01	00 - Non-Monitored Optex OS-12C. 01 - Photo Beam Pro and Monitored Optex OS-12C T.	01	01
21*	01	50	Lock Delay (0.1 – 5.0 sec).	01	01

Continued on following page.

**NOTE:** Door must be cycled open for changes to be stored in permanent memory.

\* Not currently available on Palm.

Copyright 2016, Stanley Access Technologies, LLC. All rights reserved. Reproduction in whole or in part without the express written permission of Stanley is prohibited.

12.28.2016

**Table 3. Settings (continued)**

22	00	64	Open Stop. Distance (1/8" increments) from full open the door will stop.	06	06
24	00	01	Access Control Pro. 00 = off, 01 = on.	00	00
25	00	03	Press Time, 00 = least amount, 03 = most amount of pressing. After obstruction timeout, the number of seconds the door presses at Full Closed.	00	00
28	00	20	Open Check Boost. Transition speed from braking to check.	02	02
29	00	20	Close Check Boost. Transition speed from braking to check.	02	02

**Table 4. Status Codes**

Status Code	Description	Remediation IF Necessary
00	Normal operation—All OK	
0b	Obstruction	
20	Breakout	
33	System error	See attachment 7
34	Internal Communication Error – Type 1	See attachment 7
35	Motor Drive Failure	Replace Controller
36	Internal Communication Error – Type 2	See attachment 7
A0	First installation sequence (FIS)	
A1	Auto-configuration sequence	
A2	Auto-configuration confirmation sequence	
b1	Encoder error	
Ld	Lock Down (Shear Lock Energized)	
db	Output Control	See Attachment 6, Sheet 2 of 2
dc	Display door cycle counter	
dE	Delayed Egress	
dL	Shear Lock De-Energized	
E1	Upper hold beam sensor error	Verify sensor wiring and safety logic setting
E3	Door length error	Re-do first installation sequence (FIS)
F0	Inside Monitored sensor failure	Verify sensor wiring and safety logic setting
F1	Outside Monitored sensor failure	Verify sensor wiring and safety logic setting
F2	Upper Photo Beam Pro sensor failure	Check transmitter, receiver, and hold beam type
F3	Lower Photo Beam Pro sensor failure	Check transmitter, receiver, and hold beam type
ho	Door held open	Check sensors and hold beam type

Copyright 2016, Stanley Access Technologies, LLC. All rights reserved. Reproduction in whole or in part without the express written permission of Stanley is prohibited.

**Table 5. Door States**

Door State	Description
00	Door State is Closed
02	Door State is Opening
03	Open Braking
04	Door State is in Open Check
06	Door State is Full Open
07	Door State is Closing
09	Door State is in Close Check
15	Door State is in Open Stop
16	Door State is in Recycle or Obstruction While Closing
17	Door State is in Close Press

**NOTE:** If the current status code is “Normal operation—All OK”, the MC521 Pro will show the current door state. Otherwise, the MC521 Pro alternates between showing the current status code and the door state.

## Final Tune-In Adjustments

1. Refer to ANSI A156.10, “American National Standard for Power Operated Doors,” and attachment 4 and DETERMINE ANSI and UL door operating requirements.
2. IF Stanguard™ threshold sensor is installed, refer to Stanley Access Technologies document No. 203768, “Stanguard™ Threshold Sensor Installation and Operation,” and TUNE-IN Stanguard™ threshold sensor. Ensure that the JP200 Jumper is properly installed for StanGuard™ Sensors.
3. IF SU-100 motion sensor(s) are installed, refer to Stanley Access Technologies document No. 203957, “SU-100 Motion Sensor Installation and Operation,” and TUNE-IN SU-100 motion sensor(s).
4. IF Optex X Zone T or X Zone ST Sensors are installed, refer to the manufacturer’s installation and tune-in instructions.
5. To ensure that all settings have been stored in EEPROM memory, turn power OFF and then back ON. Repeat step 1 above.
6. If Hotron HR100 ST Sensors are installed, refer to the manufacturer’s installation and tune-in instructions.
7. Verify that the correct Safety Logic has been selected for Sensor Monitoring and that the JP200 is in the correct position.
8. DO NOT remove JP200 when Stanguard™ is installed. X Zone T, X Zone ST and HR100 ST monitored sensors require JP200 to be removed.

Copyright 2016, Stanley Access Technologies, LLC. All rights reserved. Reproduction in whole or in part without the express written permission of Stanley is prohibited.

12.28.2016

**Table 6. Spare Parts List**

Description	Part Number
MC521 Pro Controller, includes 4 terminal blocks	314117
MC521 Pro Controller Manual	204066
Harness, Rocker Switch to Control Box, 98 inches	414098
Harness, Rocker Switch to Control Box, 180 inches	414099
Harness, Holding Beam to Control Box, 24 inches	414106
Harness, Rotary Switch to Control Box, 180 inches	414107-1
Harness, Rotary Switch to Control Box, 480 inches	414107-2
Harness, Power, 18 inches	415000
Harness, Encoder Cable Adapter, 12 inches	415001
Harness, Solenoid Lock, 67 inches (See Note)	516922-1
Harness, Solenoid Lock, 124 inches (See Note)	516922-2
Harness, Solenoid Lock Pigtail	516921
Power Supply 24VDC	516871
Terminal Block Plug, 10 position	714055
Bluetooth Adapter Kit	314215 For a list of compatible handheld devices; visit : <a href="http://www.stanleyaccess.com">http://www.stanleyaccess.com</a> Select Door Service > Technician Mobile Downloads > Android Apps. Select Compatible Handheld Devices Document.
Compatible Handheld Device	For a list of compatible handheld devices; visit : <a href="http://www.stanleyaccess.com">http://www.stanleyaccess.com</a> Select Door Service > Technician Mobile Downloads > Android Apps. Select Compatible Handheld Devices Document.
Harness, motor, 14 feet	413362
Harness, motor, 17 feet	413362-1
Harness, line connect, 6 feet	412544
Harness, line connect, 10 feet	412545
Harness, Rocker Switch to Control Box, 252 inches	414126
Harness, Solenoid Lock Power Signal, 264 inches	516823-4
Harness Motor Extension, 42 inches	411746
Counter, External Accessory	413787
MC521 Comm Extension Retro Kit, 6 feet	313995
MC521 Comm Extension Retro Kit, 40 feet	313996
Harness, Encoder Extension 40 inches	415079
<b>NOTE:</b> When replacing a solenoid lock harness, solenoid lock pigtail harness 516921 is required for solenoid locks that do not have a pigtail.	

Copyright 2016, Stanley Access Technologies, LLC. All rights reserved. Reproduction in whole or in part without the express written permission of Stanley is prohibited.



## Attachment 1 MC521 Pro Controls and Indicators (Sheet 1 of 2)

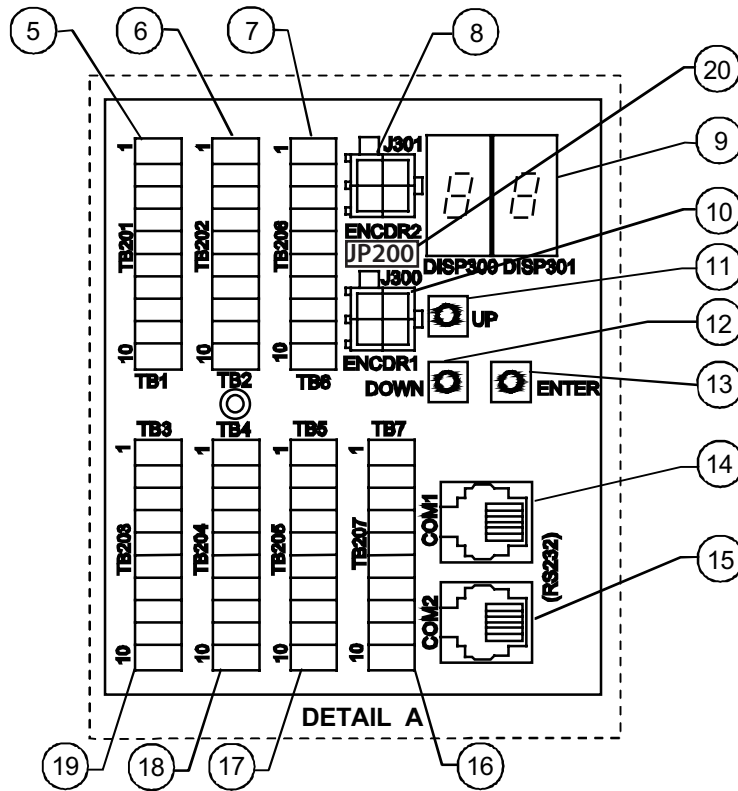
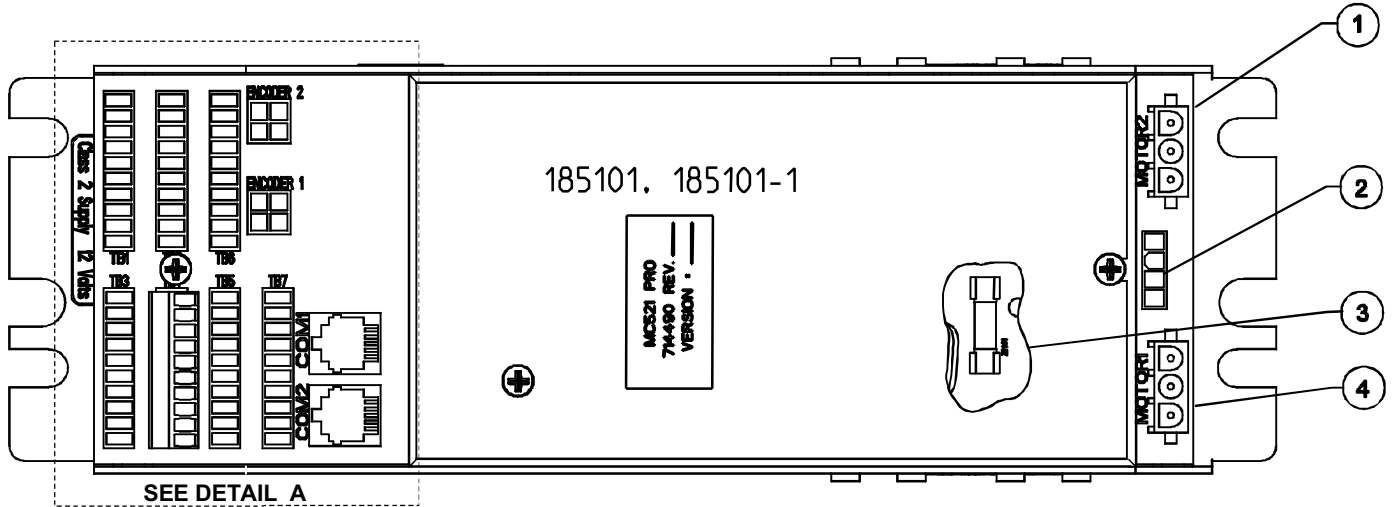

**NOTE: See next page for indicators and descriptions**

**Attachment 1  
MC521 Pro Controls and Indicators  
(Sheet 2 of 2)**

ITEM	CONTROL/INDICATOR	DESCRIPTION
1	Motor 2 Connector P402	Motor No. 2 connector.
2	Power Connector J500	Connection point for incoming line, neutral, and common power wiring.
3	Fuse F500	Controller fuse-- 5 Amp, 250V
4	Motor 1 Connector P401	Motor No. 1 connector.
5	Terminal Block Connector TB1	Connection point for solenoid lock control.
6	Terminal Block Connector TB2	Connection point for function switch (rotary or rocker).
7	Terminal Block Connector TB6	Includes spare I/O and AUX DC supply. Do not populate TB6 until further notice.
8	Encoder 2 Connector J301	Not used.
9	Two Digit Display	Displays Controller Status. Also serves as the display for tune-in by pushbutton switches and indicates encoder movement.
10	Encoder 1 Connector J300	Connection point for motor encoder No. 1.
11	Up Pushbutton Switch SW300	Used for manual setup and tuning of door when PDA is not available.
12	Down Pushbutton Switch SW301	Used for manual setup and tuning of door when PDA is not available.
13	Enter Pushbutton Switch SW302	Used for manual setup and tuning of door when PDA is not available.
14	COM1 Jack	RS232 COM1 connector. Connection point for PDA harness.
15	COM2 Jack	RS232 COM2 connector. Not used.
16	Terminal Block Connector TB7	Includes RS485 and AUX DC supply. Do not populate TB7 until further notice.
17	Terminal Block Connector TB5	Connection point for side-screen sensor and closed-position switch.
18	Terminal Block Connector TB4	Connection point for inside sensor, outside sensor and push plate.
19	Terminal Block Connector TB3	Connection point for Stanguard™, doorway holding beam, and breakout switch. Using jumper wires across TB3 terminals 1 to 5 and 2 to 6, internal transformer supplies power to multiple external sensors.
20	Jumper JP200	Jumper needs to be installed for all Stanguard™ installations. Jumper needs to be removed for X Zone T, X Zone ST, HR100 C T and some other Monitored Sensors.

Copyright 2016, Stanley Access Technologies, LLC. All rights reserved. Reproduction in whole or in part without the express written permission of Stanley is prohibited.

12.28.2016



## Attachment 2 MC521 Pro System Wiring Diagram (Sheet 2 of 10)

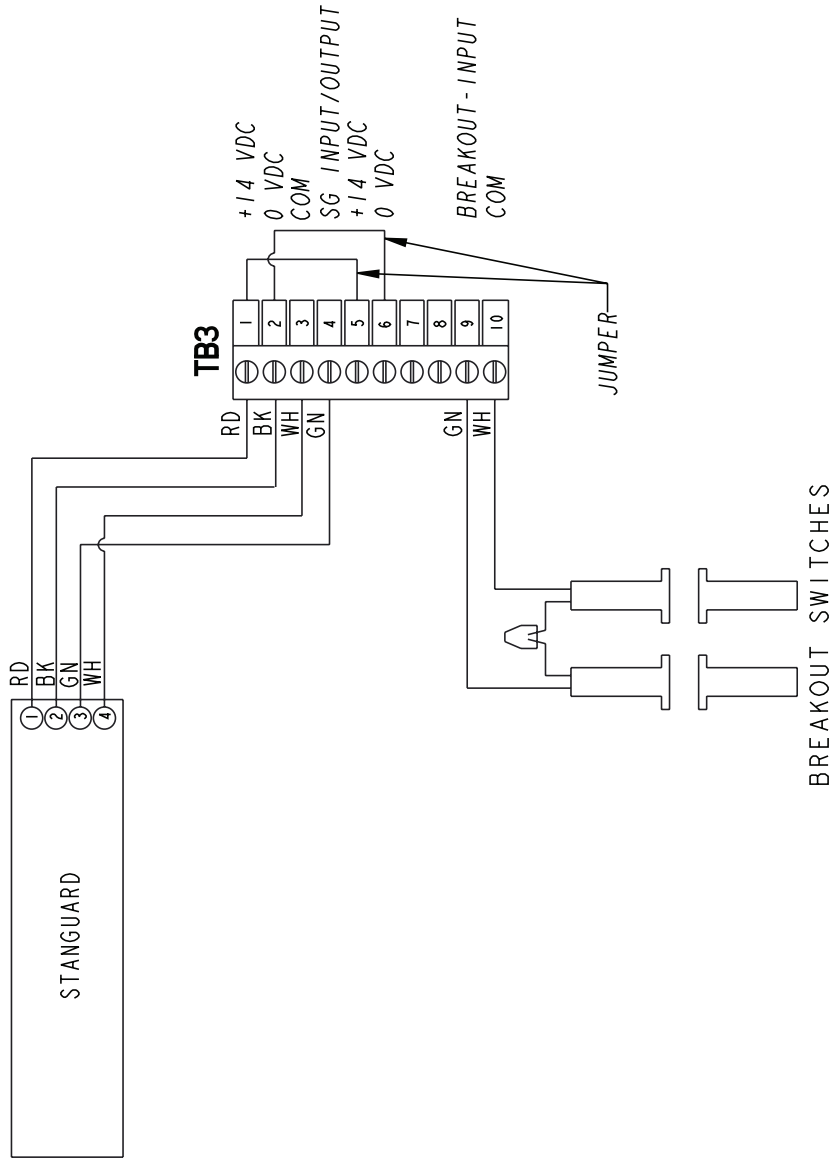

## Attachment 2 MC521 Pro System Wiring Diagram (Sheet 3 of 10)

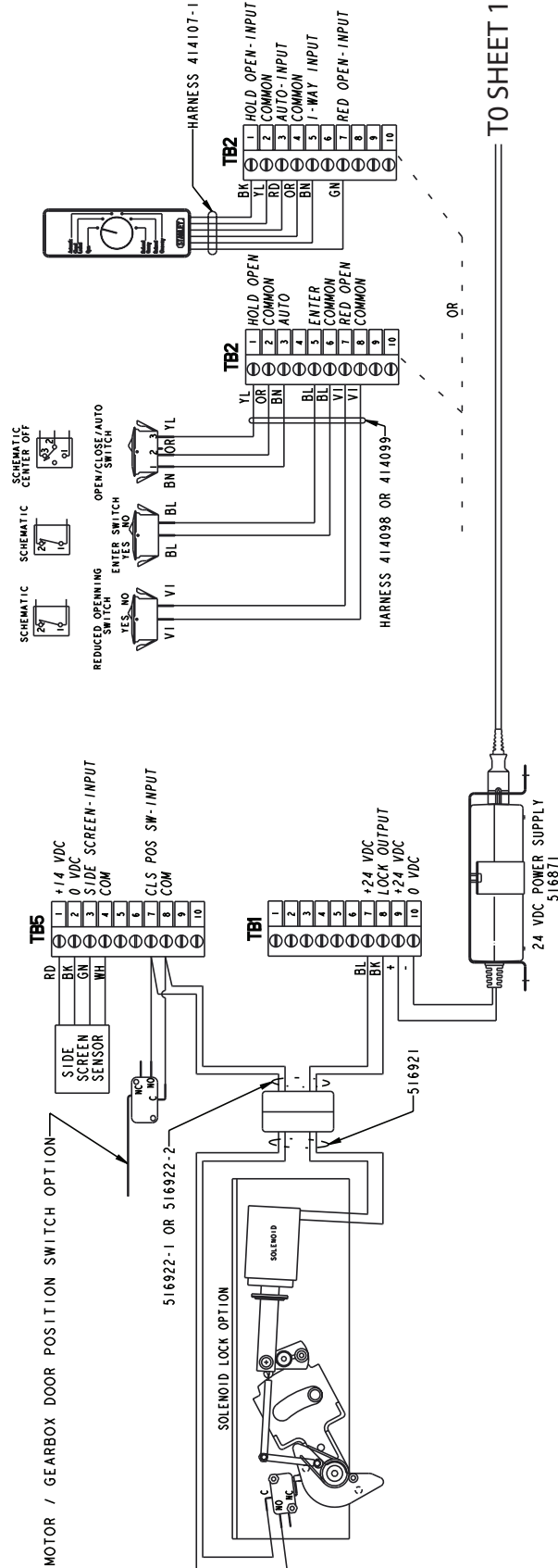

## Attachment 2 MC521 Pro System Wiring Diagram (Sheet 4 of 10)

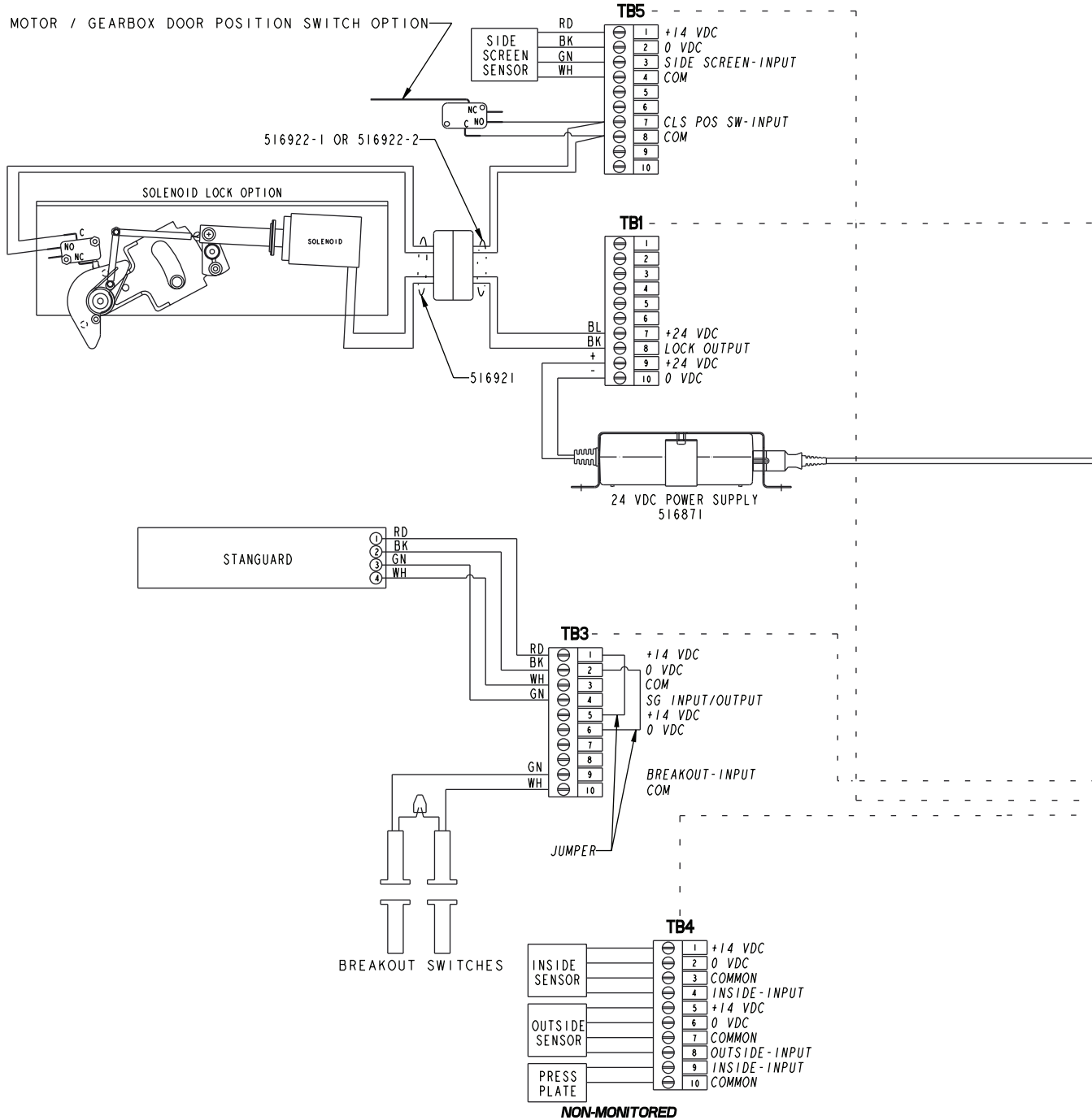

Copyright 2016, Stanley Access Technologies, LLC. All rights reserved. Reproduction in whole or in part without the express written permission of Stanley is prohibited.

12.28.2016

## Attachment 2 MC521 Pro System Wiring Diagram (Sheet 4 of 10, continued)

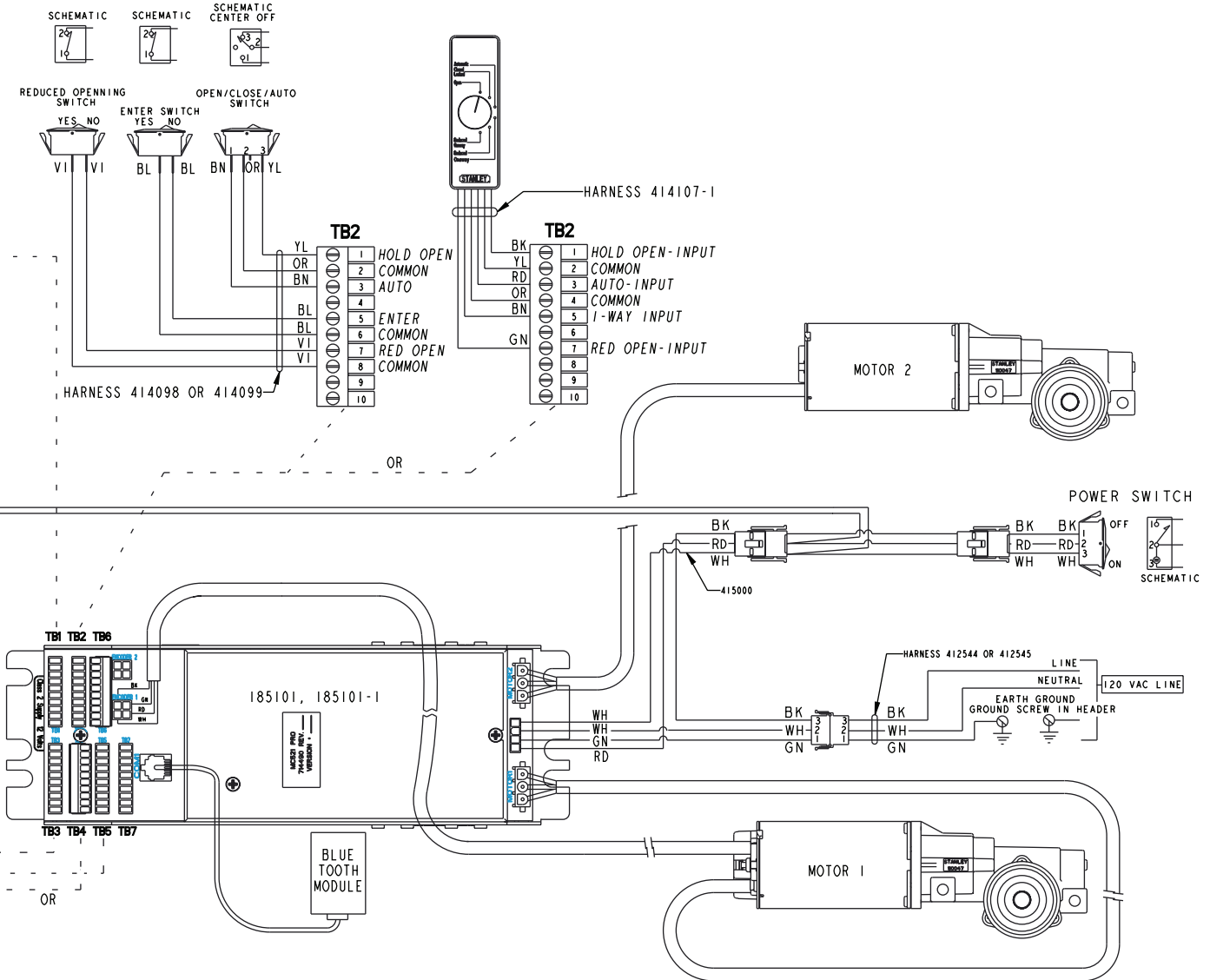

Copyright 2016, Stanley Access Technologies, LLC. All rights reserved. Reproduction in whole or in part without the express written permission of Stanley is prohibited.

12.28.2016

## Attachment 2 MC521 Pro System Wiring Diagram (Sheet 5 of 10)

### PHOTO BEAM PRO HOLDING BEAM

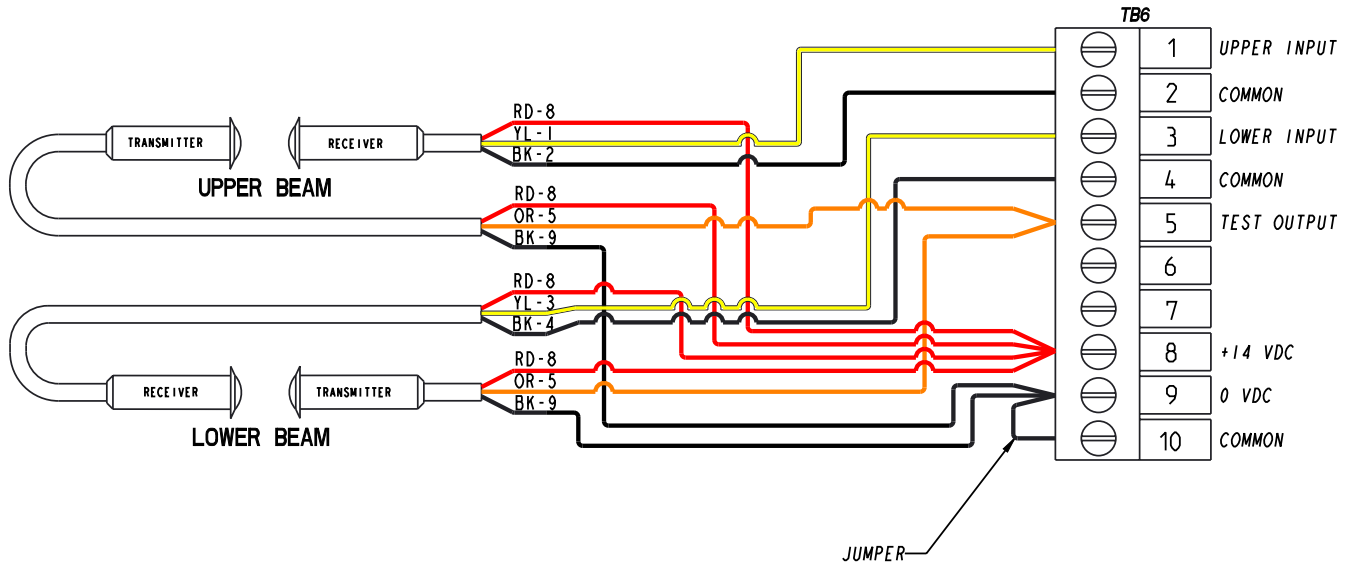

TB6	COLOR	DUAL HOLDING BEAM WIRING
1	YL	OUTPUT UPPER RECEIVER
2	BK	(-) UPPER RECEIVER
3	YL	OUTPUT LOWER RECEIVER
4	BK	(-) LOWER RECEIVER
5	OR	TRANSMITTER CONTROL LOWER AND UPPER
6	--	NO CONNECTION
7	--	NO CONNECTION
8	RD	(+) ALL RECEIVERS AND TRANSMITTERS
9	BK	(-) LOWER AND UPPER TRANSMITTERS, JUMPER TO TB6-10
10	BK	JUMPER FROM TB6-9



**Attachment 2**  
**MC521 Pro System Wiring Diagram**  
**(Sheet 6 of 10)**

**OPTEX OS-12C T**  
**DOORWAY HOLDING BEAM**

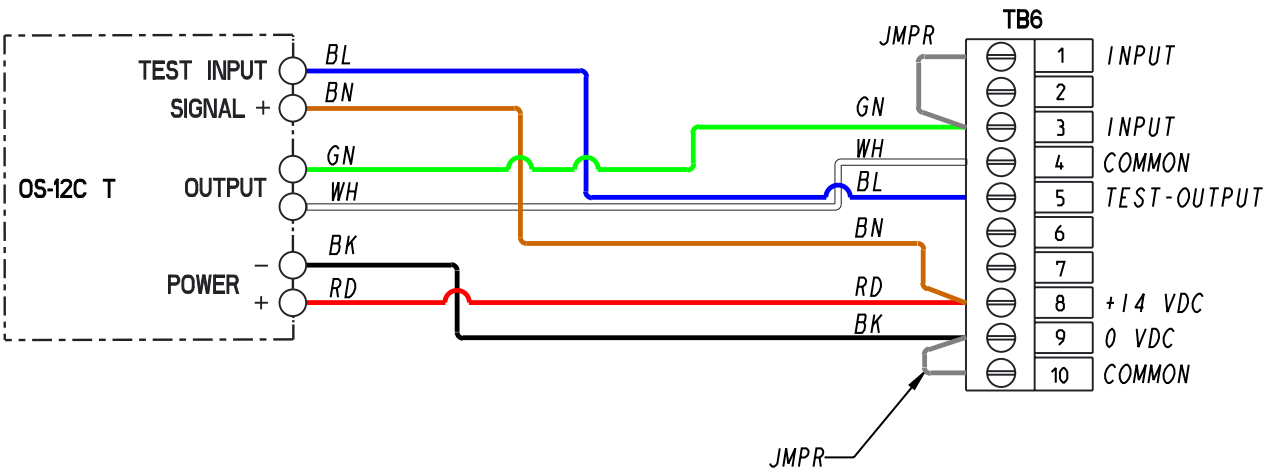

Program the OS-12 CT set to "D" - Active High / N.C.  
 On the MC521 Pro set Index 20 to Value 01 (Hold Beam Pro).

Copyright 2016, Stanley Access Technologies, LLC. All rights reserved. Reproduction in whole or in part without the express written permission of Stanley is prohibited.

12.28.2016

## Attachment 2 MC521 Pro System Wiring Diagram (Sheet 7 of 10)

### PHOTO BEAM PRO BREAKOUT BEAM

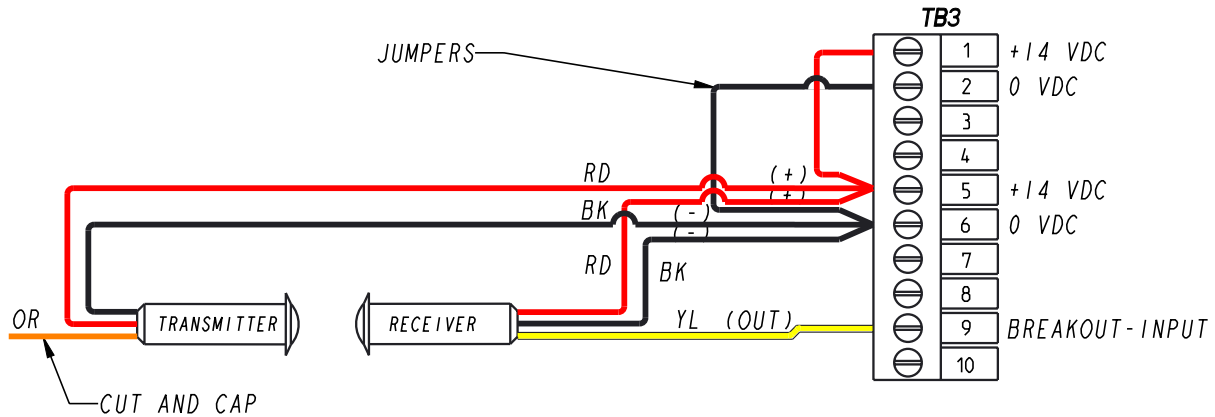

TB3	COLOR	PHOTO BEAM PRO BREAKOUT BEAM
1	RD	JUMPER FROM TB3-5
2	BK	JUMPER FROM TB3-6
3	--	NO CONNECTION
4	--	NO CONNECTION
5	RD	JUMPER FROM TB3-1, (+) RECEIVER AND TRANSMITTER
6	BK	JUMPER FROM TB3-2, (-) RECIEVER AND TRANSMITTERS\
7	--	NO CONNECTION
8	--	NO CONNECTION
9	YL	OUTPUT RECEIVER
10	--	NO CONNECTION

## Attachment 2 MC521 Pro System Wiring Diagram (Sheet 8 of 10)

### X ZONE T & ST 2 MONITORED SENSORS

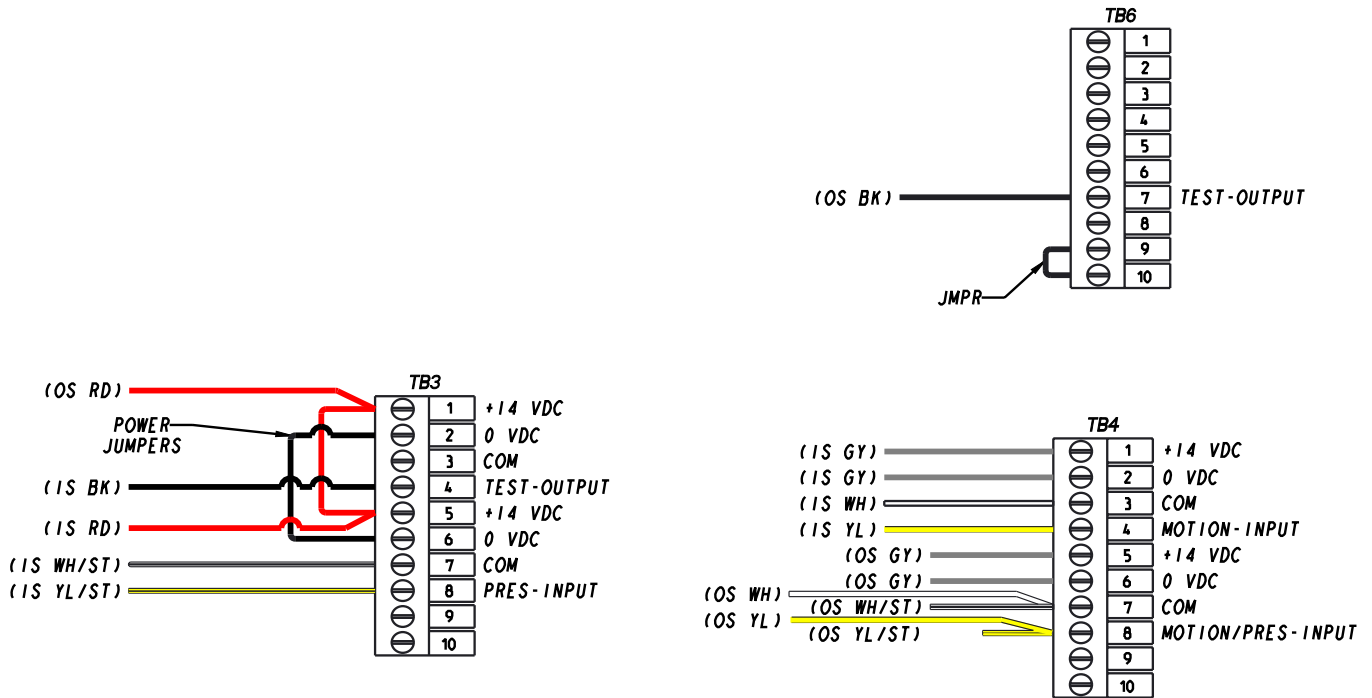

#### X Zone ST

Key DIP Switch settings: 10 and 11 **DOWN**; 12, 14 and 15 **UP**.

#### MC521 Pro

Remove JP200.

Set index 19 to Value = 00 (Sensor Monitoring with Threshold Control).

#### X Zone T

Key DIP Switch settings: 11 and 12 **DOWN**; 13 and 15 **UP**.

#### MC521 Pro

Remove JP200.

Set index 19 to Value = 03 (Sensor Monitoring).

## Attachment 2 MC521 Pro System Wiring Diagram (Sheet 9 of 10)

### X ZONE T & ST 4 MONITORED SENSORS

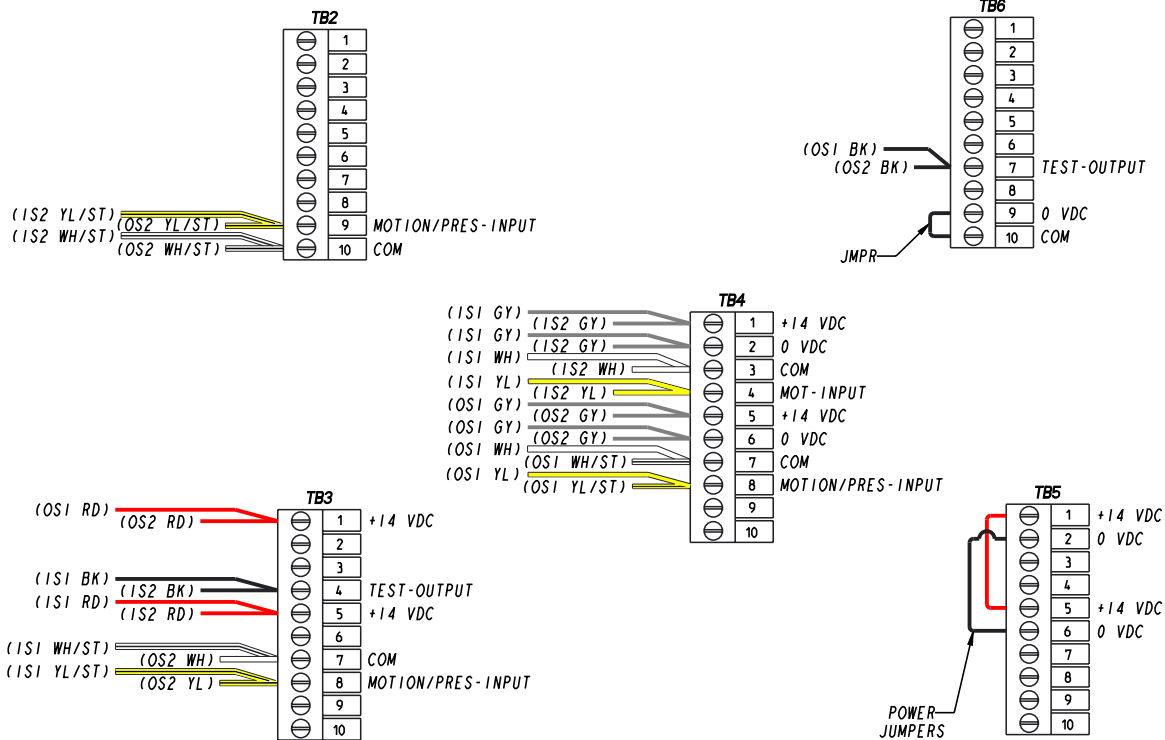

#### X Zone ST

Key DIP Switch settings: 10 and 11 **DOWN**; 12, 14 and 15 **UP**.

#### MC521 Pro

Remove JP200.

Set index 19 to Value = 01 (Monitored 4 Sensors - Threshold Zone Control).

#### X Zone T

Key DIP Switch settings: 11 and 12 **DOWN**; 13 **UP** and 15 **UP**.

#### MC521 Pro

Remove JP200.

Set index 19 to Value = 05 (Monitored 4 Sensors).

## Attachment 2 MC521 Pro System Wiring Diagram (Sheet 10 of 10)

HOTRON HR100-ST

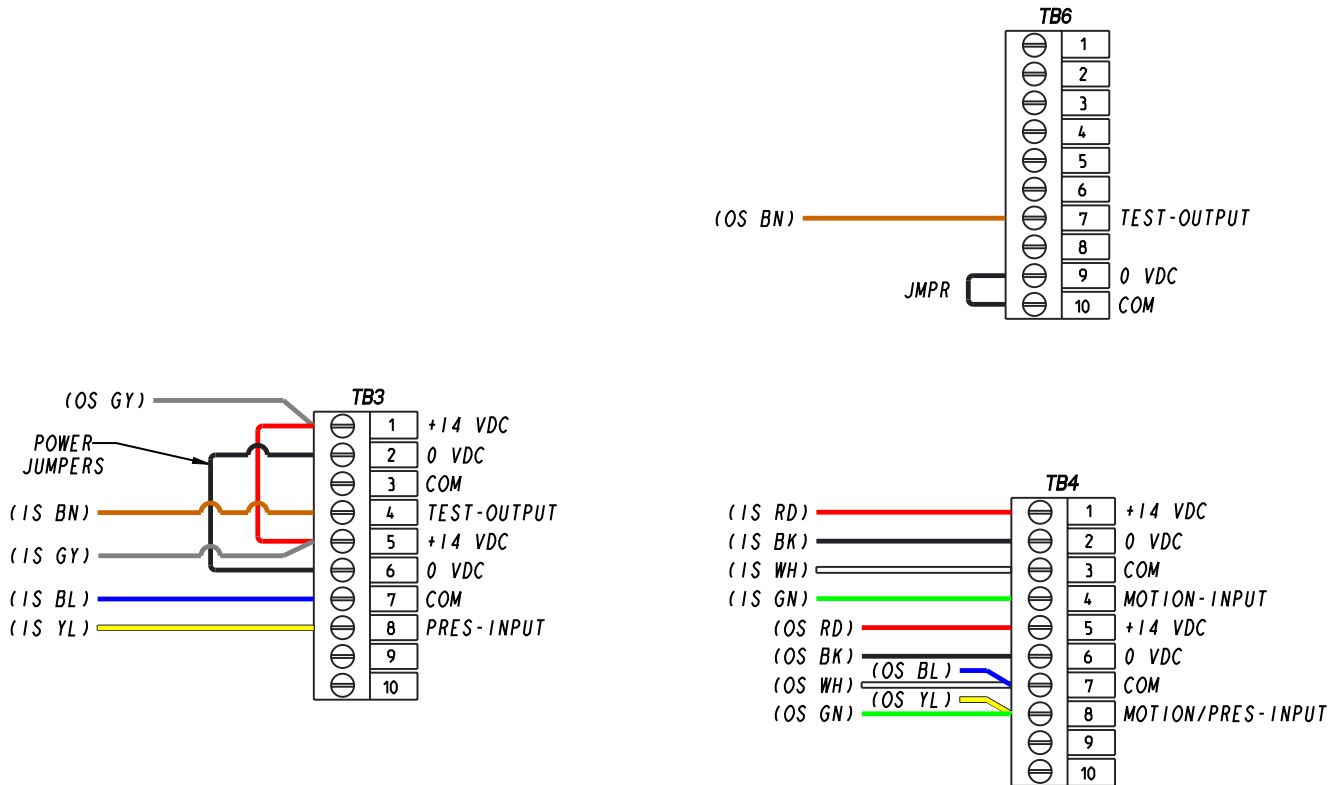

### HR100 ST

Recommended DIP Switch settings:

DIP Switch X: (2, 3, 4, 5, 6, 7 and 8 = **UP**) (1=**DOWN**).

DIP Switch Y: (1, 2, and 4 = **UP**) (5 and 6 = **DOWN**).

{**UP = OFF**} {**DOWN = ON**}

### MC521 Pro Settings

Remove JP200.

Set index 19 to Value = 03 (Sensor Monitoring).

## Attachment 3 MC521 Pro Terminal Block Connections -- TB1 through TB7 (Sheet 1 of 1)

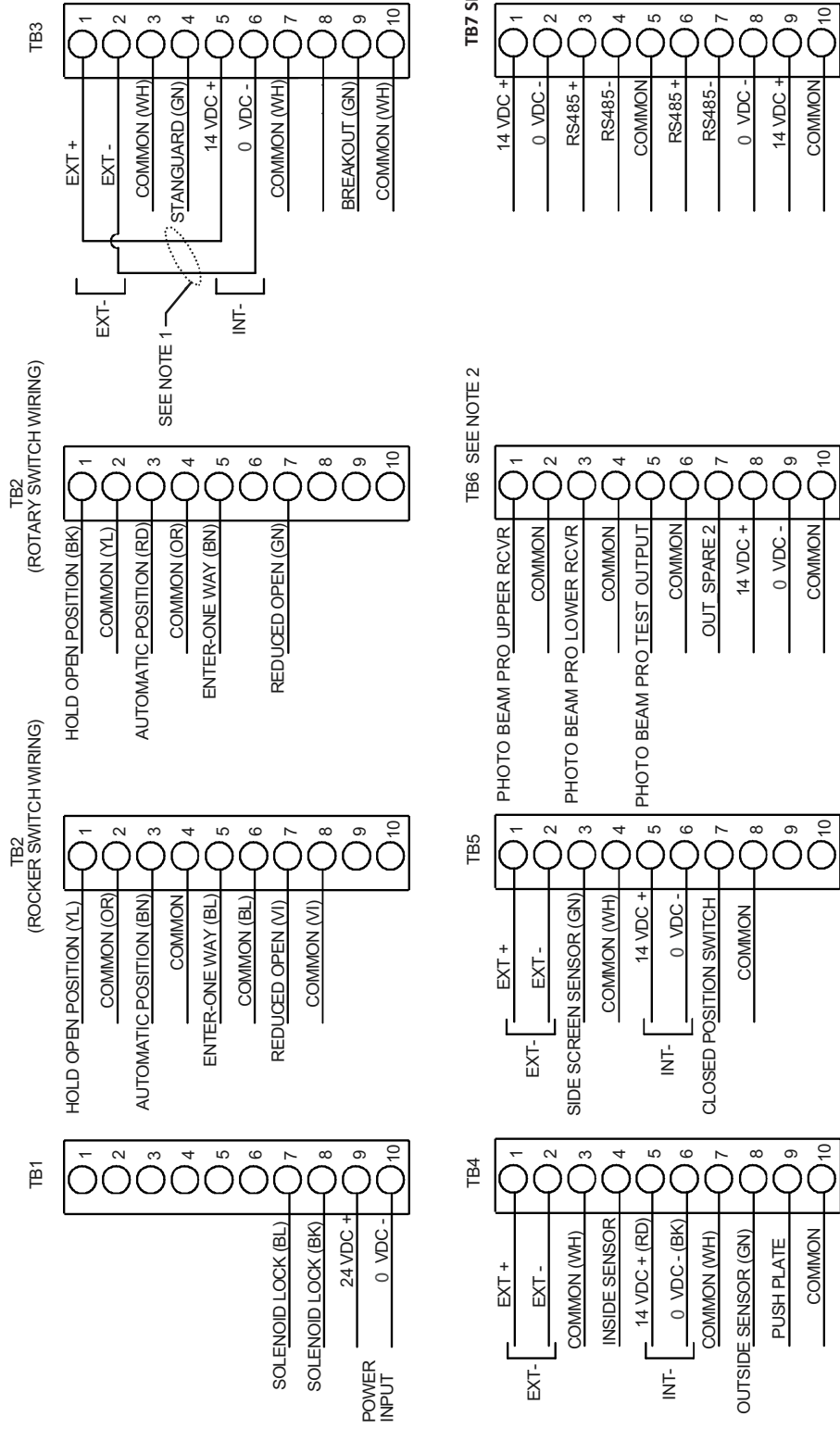

- NOTES**
1. REMOVE IF EXTERNAL POWER SUPPLY IS USED.
  2. TB6 HAS SPARE I/O AND AUX DC SUPPLY.
  3. TB7 HAS RS485 AND AUX DC SUPPLY.

12.28.2016 Copyright 2016, Stanley Access Technologies, LLC. All rights reserved. Reproduction in whole or in part without the express written permission of Stanley is prohibited.

## Attachment 4 ANSI/BHMA and UL Compliance Requirements for Sliding Doors (Sheet 1 of 2)

Final adjustment and proper operation of the door system must be and shall be performed in the field.

**NOTE:** These instructions are for informational purposes and do not substitute for review against the current revision of the referenced standards. Where a requirement exists in multiple standards, such as the ANSI/BHMA standard and the UL standard, the more restrictive condition applies. Other local codes and fire codes likely exist, and must also be followed.

### ANSI/BHMA A156.10 Sliding Door Systems

---

Sliding door systems must be installed and adjusted for compliance with the current version of ANSI/BHMA A156.10, "American National Standard for Power Operated Pedestrian Doors".

Critical aspects of the installation for compliance with A156.10 include:

- Control mat size, layout, molding height, active areas and sensitivity.
- Sensor pattern size, sensitivity, and function.
- Knowing Act guidelines and secondary activating zone.
- Entrapment protection rules including door speeds, forces, and time delays.
- Signage. (Decals and application instructions are provided with the door system.)

### UL 325 Compliance

---

All power operated door systems must be installed in compliance with the current edition of UL 325, "Standard for Safety for Door, Drapery, Gate, Louver, and Window Operators and Systems".

#### Wiring

1. To reduce the risk of electric shock proper and reliable grounding is mandatory. See **Main Power Wiring** instructions and **Wiring Diagrams** in this guide for grounding techniques.
2. Permanent wiring is to be employed as required by the National Electrical Code and/or local codes.
3. Connection of external devices is shown in the wiring diagrams and terminal block layouts elsewhere in this guide. Refer to these figures for proper wiring of external devices to ensure compliance with UL 325.

#### Knowing Act

Doors activated by a manual switch (Knowing Act switch in ANSI/BHMA terms) must have the switch installed in a location from which operation of the door can be observed by the person operating the switch.

## Attachment 4 ANSI/BHMA and UL Compliance Requirements for Sliding Doors (Sheet 2 of 2)

To ensure that a sliding door operates in accordance with UL 325 entrapment protection criteria the following must be established:

- Manual opening force (sliding doors without breakout) or breakout force with power on or off must be less than 50 lbf (222.4 N).
- Closing force must be less than 30 lbf (133.4 N).
- A closing sliding door must not develop kinetic energy in excess of 2.5 ft-lbf (3.39 J). This is achieved by proper setting of the closing speed. See section entitled “Closing Speed”.
- Maximum recommended door weight:
  - Dura-Glide 5000 Series = 150 lbs (70 kg) per panel.
  - Dura-Glide/Dura-Guard/Dura-Storm and similar 2000/3000 Series = 220 lbs (100 kg) per panel.
  - IS10000/Double Diamond and similar Industrial Series = 300 lbs (90 kg) per panel

### Closing Speed

Closing speed is measured over a travel distance of 2 or 3 feet. On smaller bi-part doors there may only be 2 feet of movement before the door system enters close-check (latch check). The time measurement should start once the door has achieved closing speed, usually 6 inches from full open. Mark this point on the floor with tape or other object. Measure from this point 2 or 3 feet toward the closed position and mark the next point. Use a stopwatch to measure the time it takes for the sliding panel to travel this distance during normal closing cycles. Make sure the door system is not braking or entering close-check during the measurement. Repeat the measurement 3 times and use the average value. The allowed time for a sliding panel to cover this distance during the closing cycle is given in the table below.

Door Weight (pounds)	Closing Time (seconds) 2 foot measurement	Closing Time (seconds) 3 foot measurement
160 or less	2.0	3.0
161 to 180	2.1	3.2
181 to 200	2.2	3.3
201 to 220	2.3	3.5
221 to 240	2.4	3.7
241 to 260	2.5	3.8
261 to 280	2.6	4.0
281 to 300	2.7	4.1



## Attachment 5 -- Handheld Device Troubleshooting Aid (Sheet 1 of 1)

Terminal and Pin	Description	State
TB1-8	Solenoid Lock Output	Dark = Unlocked
	w/o PCB, fail secure	Dark = Unlocked
	w/o PCB, fail safe	Dark = Locked

Rotary Function Switch States for TB2						
	Hold Open	Closed Locked	Automatic	One Way	Reduced	Reduced One Way
TB2-1						
TB2-3						
TB2-5					Don't Care	Don't Care
TB2-7						

Rocker Function Switch States for TB2						
	Hold Open	Closed Locked	Automatic	One Way	Reduced	Reduced One Way
TB2-1						
TB2-3						
TB2-5	Don't Care	Don't Care				
TB2-7	Don't Care	Don't Care				

Terminal and Pin	Description	State
TB3-4	Stanguard™ Input/Output	Dark = triggered or detecting
TB3-8 & TB4-8	Holding Beam Input & Outside Sensor (connected internally)	Dark = detecting
TB3-9	Breakout Input	Dark = no breakout
TB4-4 & TB4-9	Inside Sensor Input & Push Plate Input (connected internally)	Dark = detecting
TB4-8 & TB3-8	Outside Sensor & Holding Beam Input (connected internally)	Dark = detecting
TB4-9 & TB4-4	Push Plate Input & Inside Sensor Input (connected internally)	Dark = detecting
TB5-3	Side Screen Sensor Input	Dark = detecting
TB5-7	Closed-Door Position Switch Input	Dark = closed
TB5-10	Spare	
TB6-1	Photo Beam Pro Upper Holding Beam	Dark = unobstructed White = detecting
TB6-3	Photo Beam Pro Lower Holding Beam	Dark = unobstructed White = detecting
TB6-5	Photo Beam Pro Test Output	Dark = testing
TB6-7		

Copyright 2016, Stanley Access Technologies, LLC. All rights reserved. Reproduction in whole or in part without the express written permission of Stanley is prohibited.

12.28.2016

## Attachment 6 Handheld Device Troubleshooting Screen Descriptions (Sheet 1 of 2)

- TB1-8** = Solenoid Lock Output
- TB2-1** = Hold Open Function Switch Input
- TB2-3** = Automatic Function Switch Input
- TB2-5** = Enter/One Way Function Switch Input
- TB2-7** = Reduced Open Function Switch Input
- TB2-9** = Reduced Open/One Way Function Switch Input
- TB3-4** = Stanguard™ Input/Output or  
Monitored Inside Sensor Test Output
- TB3-8** = Holding Beam Input or  
Monitored Inside Sensor Presence Input
- TB3-9** = Breakout Input
- TB4-4** = Inside Sensor Input
- TB4-8** = Outside Sensor Input
- TB4-9** = Push Plate Input
- TB5-3** = Side Screen Sensor Input
- TB5-7** = Closed-Door Position Switch Input
- TB5-10**
- TB6-1** = Photo Beam Pro Upper Holding Beam
- TB6-3** = Photo Beam Pro Lower Holding Beam
- TB6-5** = Photo Beam Pro Test Output
- TB6-7** = Monitored Outside Sensor Test Output

## Attachment 6 Handheld Device Troubleshooting Screen Descriptions (Sheet 2 of 2)

### Output Control Mode

The Output Control allows the user to run the MC521 Pro Control Box in a debug mode. The Output Control is located on the MC521 Troubleshooting Screen.

The MC521 Pro firmware needs to be above 7.97 for the Toolbox to have Output Control Mode functionality.

The MC521 Pro displays “**db**” to indicate that the control box is in the debug state.

The function switch must be selected to Closed/Locked or Hold Open in order to use the Output Control Mode.

Output Control Mode can also be used when the MC521 Pro control box is in “**AO**”.

1. Select **TROUBLESHOOTING** on the Main selection menu.
2. Press and hold the output that is to be controlled.

**TOGGLE/PULSE** should appear.

The Output Control Mode is enabled when the Red “LED” indicator is ON.

3. Press **TOGGLE** or **PULSE**. In 1 second, the output will change state or pulse.

The inputs on the troubleshooting are live and indicate their present state.

When Output Control Mode is **ON**, the Turbo functionality is automatically activated.

The MC521 Pro will time out after 5 minutes when there is no activity from the MC521 Toolbox. The Output Control Mode can be turned **OFF** by changing the function switch to a setting other than Closed/Locked or Hold Open. The Output Control Mode is **OFF** when the text and Red “**LED**” indicator are hidden from the Troubleshoot screen.

4. Refer to the Tech Tip Library for additional instructions.

**Attachment 7  
MC521 Pro Troubleshooting Aid  
(Sheet 1 of 1)**

Symptom	Remedy
Door does not close and/or Status code displays <b>h0</b>	Use best practices to troubleshoot using handheld device and provided wiring diagrams.  Check hold beam type (index 20) Optex hold beams should be set to "Optex" and Photo Beam Pro hold beams should be set to "Photo Beam Pro."  Reference latest Photo Beam Pro Troubleshooting Tech Tip.
Handheld will not update firmware	Controller is not displaying 00. Re-FIS the door.
Door hits Open Stop/full open bumper	Increase the Open Stop parameter (index 22).
Door does not close fully (1-2" open)	Increase close press time (index 25).
Door motion is not the same as the MC521 for the same settings	Parameters value for the MC521 Pro are not the same as MC521. Refer to Table 3.
Status code displays <b>E1</b>	Verify sensor wiring and safety logic setting.
Status code displays <b>E3</b>	Check mechanical issues, components.  Increase obstruction time and torque settings. Verify compliance with ANSI/BHMA standards.  Re-do first installation sequence (FIS).
Status code displays <b>E4-E9</b>	Verify sensor wiring and safety logic setting.
Status code displays <b>F0-F1</b>	Verify sensor wiring and safety logic setting.
Status code displays <b>F2-F3</b>	Check hold beam type (index 20) Optex hold beams should be set to "Optex" and Photo Beam Pro hold beams should be set to "Photo Beam Pro."  Reference latest Photo Beam Pro Troubleshooting Tech Tip.
Door moves slowly on one cycle. Status code displays <b>33</b> or <b>34</b> or <b>36</b> momentarily (3 seconds).	Note it. No action required.
Door moves slowly on several cycles. Status code displays <b>33</b> or <b>34</b> or <b>36</b> on slow cycles.	1. Reset Power. 2. If code does not clear, Call Tech Support.

Copyright 2016, Stanley Access Technologies, LLC. All rights reserved. Reproduction in whole or in part without the express written permission of Stanley is prohibited.

## Attachment 8 Recommended Values for Different/Weights Types of Slide Door

Index	Description	Slide Doors				Dura-Max
		125 LB Single Motor Single Slide	350 LB Single Motor Bi-Part - LPH	100 LB Single Motor Bi-part	600 LB Double Diamond or Equiv.	
00	Open Speed	35	25	35	35	30
01	Close Speed	12	12	12	12	12
02	Check Speed	4	4	4	4	4
03	Open Check Length	35	35	35	40	35
04	Close Check Length	20	30	23	30	30
05	Reduced Open	1	1	1	50	50
06	Hold-open delay	15	15	15	15	15
07	Lock Logic					
08	Open torque, percent of full torque	50	25	25	60	30
09	Close torque, percent of full torque	25	25	20	7	20
10	Check torque, percent of full torque	25	25	30	7	20
11	Dura-Glide Function Switch Type					
12	2S Operation					
13	Obstruction Time	50	50	50	100	60
14	Open Acceleration Slope	60	50	60	60	50
15	Open Braking Slope	54	54	54	54	48
16	Close Acceleration Slope	20	20	20	20	20
17	Close Braking Slope	50	50	20	50	20
18	Delay Egress					
19	Safety Logic					
20	Hold Beam Type	00-Optex 01-Photo Beam pro	00-Optex 01-Photo Beam pro	00-Optex 01-Photo Beam pro	00-Optex 01-Photo Beam pro	00-Optex 01-Photo Beam pro
21	Open Stop	6	6	6	6	4
28	Close Press Time	1	1	1	1	1
29	Open Check Boost	2	2	2	2	2

Copyright 2016, Stanley Access Technologies, LLC. All rights reserved. Reproduction in whole or in part without the express written permission of Stanley is prohibited.

12.28.2016

## Attachment 9 Fine Tuning Slide Doors (Sheet 1 of 2)

### Tuning the Stanley Automatic Door

Match your actual door to one from the list of doors described in the attachment. Start by installing these settings. Use the guide below to make adjustments to these settings.

If the door:	
<b>OPENS TOO SLOWLY</b>	Increase <b>Open Speed</b> . Maximum setting is 35
	If it is too slow Increase <b>Open Torque</b>
	If it is too slow Increase <b>Open Acceleration</b>
<p>** <b>Open Torque</b> is also used to set the door open force.</p> <p>** <b>Open Speeds</b> and <b>Force</b> must comply with UL and ANSI/BHMA 156.10 requirements.</p>	
<b>HITS THE OPEN STOP</b>	Increase <b>Open Stop</b> to 8 and <b>Open Check Length</b> to 45
	Increase <b>Open Brake</b> until there is good braking.
	Increase or decrease <b>Open Check Boost</b> until there is good motion entering and in <b>Open Check</b> .
When the door braking and motion are under control, reduce the <b>Open Check</b> length as desired.	
<b>CLOSES TOO SLOWLY</b>	Increase <b>Close Speed</b> to 16
	If it is too slow Increase <b>Close Torque</b>
	If it is too slow Increase <b>Close Acceleration</b>
<p>**<b>Close Torque</b> is also used to set the door closing force. <b>Close Speed</b> and <b>Close Force</b> cannot exceed the value specified by ANSI/BHMA 156.10.</p>	

Copyright 2016, Stanley Access Technologies, LLC. All rights reserved. Reproduction in whole or in part without the express written permission of Stanley is prohibited.

## Attachment 9 Fine Tuning Slide Doors (Sheet 2 of 2)

### Tuning the Stanley Automatic Door (Continued).

Match your actual door to one from the list of doors described in the attachment. Start by installing these settings. Use the guide below to make adjustments to these settings.

If the door:	
<b>HITS THE CLOSE STOP</b> too hard	Set <b>Close Check Length</b> to 50. Set <b>Close Press</b> to 1 and test. Increase the <b>Close Brake</b> setting until there is good braking. Increase or decrease <b>Close Check Boost</b> until there is smooth motion entering and in <b>Close Check</b> .
<b>STALLS</b> during opening without any mechanical reason. . .  Continues to stall and it seems to happen at the transition from <b>Open Brake</b> to <b>Open Check</b>	Increase <b>Obstruction Time</b> from .5 seconds to 1.0 seconds
	Make small increases to <b>Open Brake Boost</b> .
<b>SPEEDS UP</b> during <b>Open Check</b>	<b>Open Check Boost</b> is set too high. Reduce it one count at a time until door motion is suitable.
<b>STALLS</b> during closing without any obvious reason. . .  Continues to stall and it seems to happen at the transition to Close Check	Increase <b>Obstruction Time</b>
	Increase <b>Close Check Boost</b> one count at a time
<b>SPEEDS UP</b> during Close Check	<b>Close Check Boost</b> is set too high. Reduce <b>Close Check Boost</b> one count at a time until door motion is suitable.

Stanley Access Technologies  
65 Scott Swamp Road  
Farmington, CT 06032

Document # 204066 REV F • [www.stanleyaccess.com](http://www.stanleyaccess.com) • 1.800.7.ACCESS