

STANLEY

**ACCESS
TECHNOLOGIES**

SOLENOID LOCKS

DURA-GLIDE DOOR PACKAGES

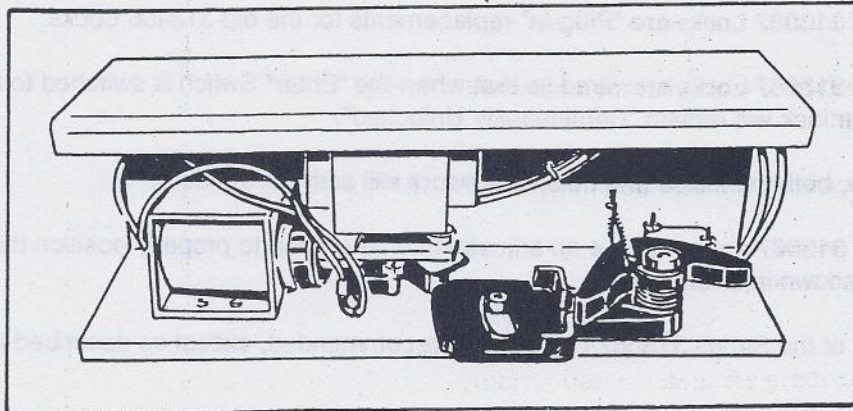

INSTALLATION MANUAL

GENERAL INFORMATION

- 1.1 The handing (right or left) of the new Series 313087 Locks cannot be changed in the field. The chart below identifies the handing required.

2000 & 3000 BI-PARTS -- RIGHT HAND LOCK REQUIRED
2000 S/S LH & 3000 S/S RH -- RIGHT HAND LOCK REQUIRED
2000 S/S RH & 3000 S/S LH -- LEFT HAND LOCK REQUIRED

- 1.2 Changing a lock from "Fail Safe" to "Fail Secure" and vice versa is possible in the field but is not recommended and should be avoided if possible. For your reference, "Fail Safe" and "Fail Secure" are defined below:

Fail Safe -- when power is lost, the door will "unlock"

Fail Secure -- when power is lost, the door will "lock"

- 1.3 The part numbers for the new Series 313087 Locks are as follows:

313087-5	Right Hand	Fail Safe
313087-6	Left Hand	Fail Safe
313087-7	Right Hand	Fail Secure
313087-8	Left Hand	Fail Secure

- 1.4 The Series 313087 Locks are "Plug-In" replacements for the old 312406 Locks.
- 1.5 The Series 313087 Locks are wired so that when the "Enter" Switch is switched to the "Yes" position, the lock will remain "Continuously Unlocked".
- In this case, both the inside and outside sensors will activate the door.
- 1.6 The Series 313087 Locks require no adjustments other than to properly position them in the header as shown in **Section 6**.
- 1.7 Lubrication of the Series 313087 Locks is not recommended, except as described in these instructions.
- 1.8 When installing the Series 313087 Lock with the new 516098 Interface Board, you must change the S1 (Lock / No Lock) Switch on the Interface Board to the "Lock" position.

REPLACING AN OLD LOCK (312406) WITH A SERIES 313087 LOCK

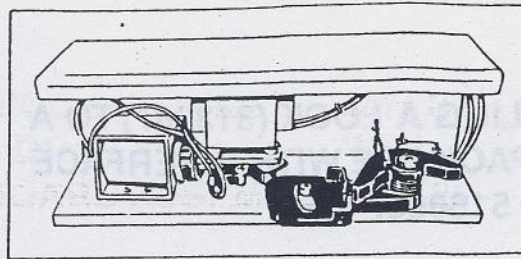

- 2.1 Turn off all power to the door package.
- 2.2 Disconnect the power connector and the control connector from the old lock.
- 2.3 With the door(s) in the fully closed position, make a mark on the track tube **approximately** at the "Locking" edge of the belt bracket.
- 2.4 Remove the old lock from the header.
- 2.5 Manually slide the door(s) to the open position.
- 2.6 Install the new lock approximately as shown in **Figure 6.1**.
- 2.7 Manually release (unlock) the lock pawl so that the latch retracts into the lock housing as shown in **Figure 6.1**.

IMPORTANT NOTE!

If the latch will not retract into the position shown in **Figure 6.1**, most probably the cam has been manually rotated so that its motion is now restricted by the switch rollers (S2 & S3). With a small screwdriver or similar tool, carefully depress the two switch rollers to release the cam and proceed.

- 2.8 Manually slide the door to the fully closed position.
- 2.9 With the door fully closed, move the lock to the position shown in **Figure 6.2** (within approximately 1/8" of the belt bracket) and tighten the lock mounting bolts.
- 2.10 Connect the power connector and the control connector to the new lock.
- 2.11 Check to be sure that the wiring is clear of the lock mechanism, the rear end of the solenoid plunger, and the belt and belt brackets. If necessary, use ty-wraps to secure the wiring in a clear position.
- 2.12 Apply a dab of lubriplate grease (or equivalent) to the locking edge of the belt bracket and the corresponding latch surface. (See **Section 6**.)
- 2.13 Restore power to the door package.
- 2.14 Operate the door and confirm proper operation.

INSTALLING A LOCK (313087) TO A DOOR PACKAGE WITH INTERFACE BOARD 516098.

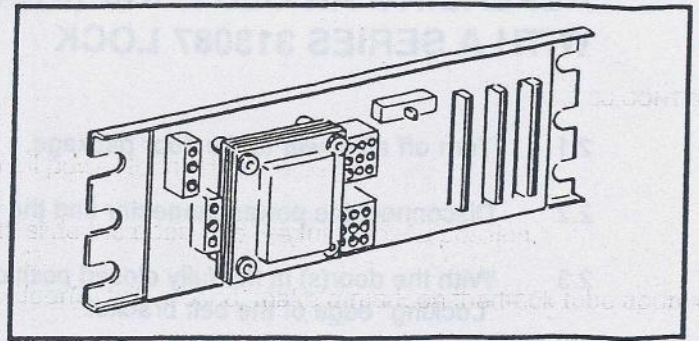

- 3.1 Turn off all power to the door package.
- 3.2 Disconnect the power connector and the control connector from the old lock.
- 3.3 With the door(s) in the fully closed position, make a mark on the track tube approximately at the "locking" edge of the belt bracket.
- 3.4 Remove the old lock from the header.
- 3.5 Manually slide the door(s) to the open position.
- 3.6 Install the new lock approximately as shown in **Figure 6.1**.
- 3.7 Manually release (unlock) the lock pawl so that the latch retracts into the lock housing as shown in **Figure 6.1**.
- 3.8 Manually slide the door to the fully closed position.
- 3.9 With the door fully closed, move the lock to the position shown in **Figure 6.2** (within approximately 1/8" of the belt bracket) and tighten the lock mounting bolts.
- 3.10 Plug Harness 412901 into J2 of the Interface Board. Route the harness to the lock. Connect the power and control connector to the lock. Refer to Wiring Diagram 110829-1.
- 3.11 Change Switch S1 (Lock / No Lock) on the Interface Board to the "Lock" position.
- 3.12 Check to be sure that all wiring is clear of the lock mechanism, the rear end of the solenoid plunger, the belt and belt brackets. If necessary, use ty-wraps to secure the wiring in a clear position.
- 3.13 Apply a dab of lubriplate grease (or equivalent) to the locking edge of the belt bracket and the corresponding latch surface. (See **Section 6**.)
- 3.14 Restore power to the door package.
- 3.15 Operate the door and confirm proper operation.

IMPORTANT NOTE!

If the latch will not retract into the position shown in **Figure 6.1**, most probably the cam has been manually rotated so that its motion is now restricted by the switch rollers (S2 & S3). With a small screwdriver or similar tool, carefully depress the two switch rollers to release the cam and proceed.

INSTALLING LOCK (SERIES 313087) TO AN EXISTING DOOR PACKAGE WITH INTERFACE BOARD ASSEMBLY 515128

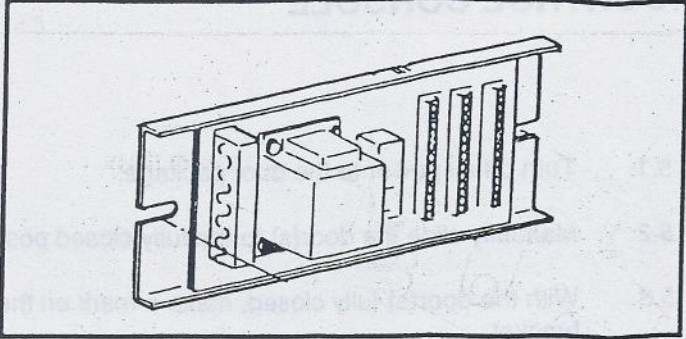

- 4.1 Turn off all power to the door package.
- 4.2 Manually slide the door(s) to the fully closed position.
- 4.3 With the door(s) fully closed, make a mark on the track tube approximately at the "locking" edge of the belt bracket.

NOTE: It is not necessary to install new belt brackets. The new lock is designed to work with existing belt brackets. The stainless steel belt bracket strike plate required with the old lock is not required with the new lock.

- 4.4 Manually slide the door(s) to the "Open" Position.
- 4.5 Install the new lock approximately as shown in **Figure 6.1**.
- 4.6 Manually release (unlock) the lock pawl so that the latch retracts into the lock housing as shown in **Figure 6.1**.

IMPORTANT NOTE!

If the latch will not retract into the position shown in **Figure 6.1**, most probably the cam has been manually rotated so that its motion is now restricted by the switch rollers (S2 & S3). With a small screwdriver or similar tool, carefully depress the two switch rollers to release the cam and proceed.

- 4.7 Manually slide the door to the fully closed position.
- 4.8 With the door fully closed, move the lock to the position shown in **Section 6** and tighten the lock mounting bolts.

4.9 Modify the existing wiring (assumed to be per Wiring Diagram #109030) and connect the Solenoid Lock in accordance with Wiring Diagram #110258 as follows:

4.9.1 Remove the jumper between Terminals #35 and #36.

- 4.9.2 Remove the white wire from Terminal #25 and connect to Terminal #22.
- 4.9.3 Remove the green wire from Terminal #34 and connect it to Terminal #24.
- 4.9.4 Remove the red wire from Terminal #27 and connect with a wire nut to red wire from Solenoid Lock Assembly, Terminal #3.
- 4.9.5 Remove the "Enter" Switch wires from Interface Board Terminals #14 and #24 and connect them to Solenoid Lock Terminal #2 and Interface Board Terminal #35.
- 4.9.6 Make a connection between Interface Board Terminals #14 and #34.
- 4.9.7 Remove the jumper between Terminals #24 and #34.
- 4.10 Connect the power connector and the control connector to the Solenoid Lock.
- 4.11 Check to be sure that all wiring is clear of the lock mechanism, the rear end of the solenoid plunger, and the belt and belt brackets. If necessary, use ty-wraps to secure wiring in a clear position.
- 4.12 Apply a dab of lubriplate grease (or equivalent) to the locking edge of the belt bracket and the corresponding latch surface. (See **Section 6**.)
- 4.13 Restore power to the door package.
- 4.14 Operate the door and confirm proper operation.

INSTALLING LOCK (SERIES 313087) TO A DOOR PACKAGE WITH ACCESS CONTROL CONSOLE

ACCESS CONTROL CONSOLE

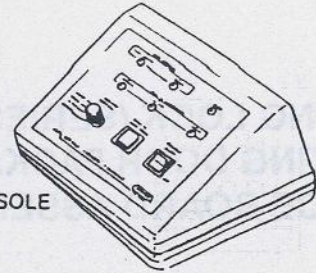

- 5.1 Turn off all power to the door package.
- 5.2 Manually slide the door(s) to the fully closed position.
- 5.3 With the door(s) fully closed, make a mark on the track tube approximately at the "Locking" edge of the belt bracket.

NOTE: It is not necessary to install new belt brackets. The new lock is designed to work with existing belt brackets. The stainless steel belt bracket strike plate required with the old lock is not required with the new lock.

- 5.4 Manually slide the door(s) to the "Open" position.
- 5.5 Install the new lock approximately as shown in **Figure 6.1**.
- 5.6 Manually release (unlock) the lock pawl so that the latch retracts into the lock housing as shown in **Figure 6.1**.

IMPORTANT NOTE!

If the latch will not retract into the position shown in **Figure 6.1**, most probably the cam has been manually rotated so that its motion is now restricted by the switch rollers (S2 & S3). With a small screwdriver or similar tool, carefully depress the two switch rollers to release the cam and proceed.

- 5.7 Manually slide the door to the fully closed position.
- 5.8 With the door fully closed, move the lock to the position shown in **Figure 6.2** and tighten the lock mounting bolts.
- 5.9 Remove the existing wiring and interface board. Install console interface board, plug-in Access Control Harness 110308 and connect in accordance with Wiring Diagram #110428.

Connect the sensors, Access Control Console and breakout switches.
- 5.10 Connect the power connector and the control connector to the Solenoid Lock.
- 5.11 Check to be sure that all wiring is clear of the lock mechanism, the rear end of the solenoid plunger, and the belt and belt brackets. If necessary, use ty-wraps to secure the wiring in a clear position.
- 5.12 Apply a dab of lubriplate grease (or equivalent) to the locking edge of the belt bracket and the corresponding latch surface. (See **Section 6.**)
- 5.13 Restore power to the door package.
- 5.14 Operate the door and confirm proper operation. (Console must be installed.)

SECTION 6
MECHANICAL INSTALLATION
(RIGHT HAND LOCK SHOWN — REVERSE FOR LEFT HAND LOCK)

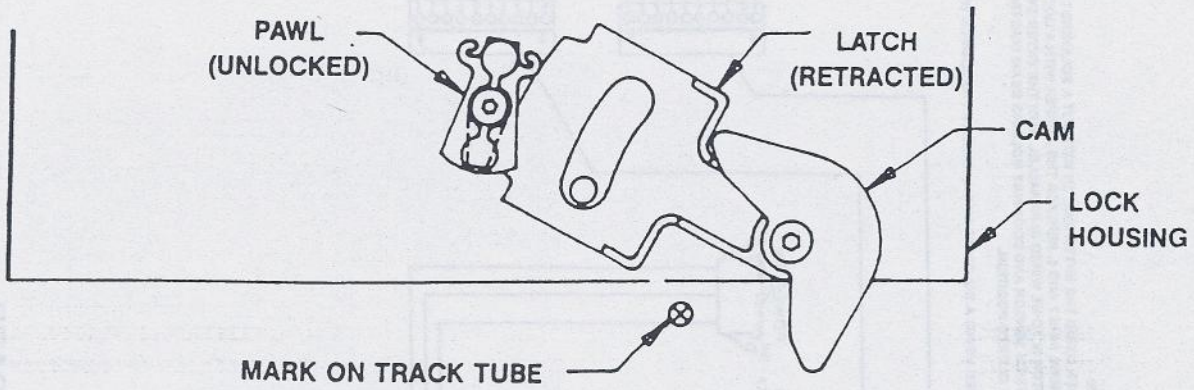

FIGURE 6.1 — "DOOR OPEN"

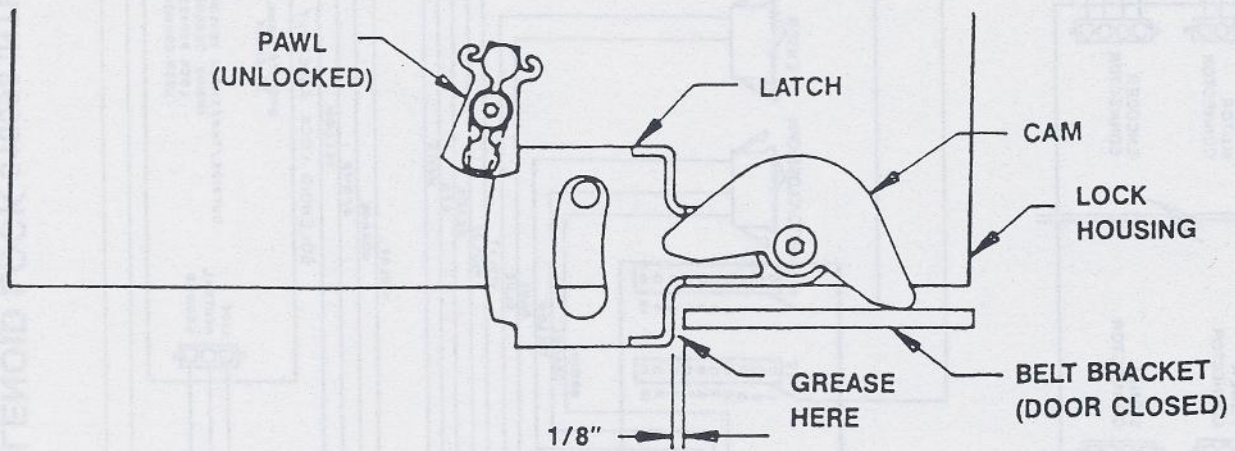

FIGURE 6.2 — "DOOR CLOSED & UNLOCKED"

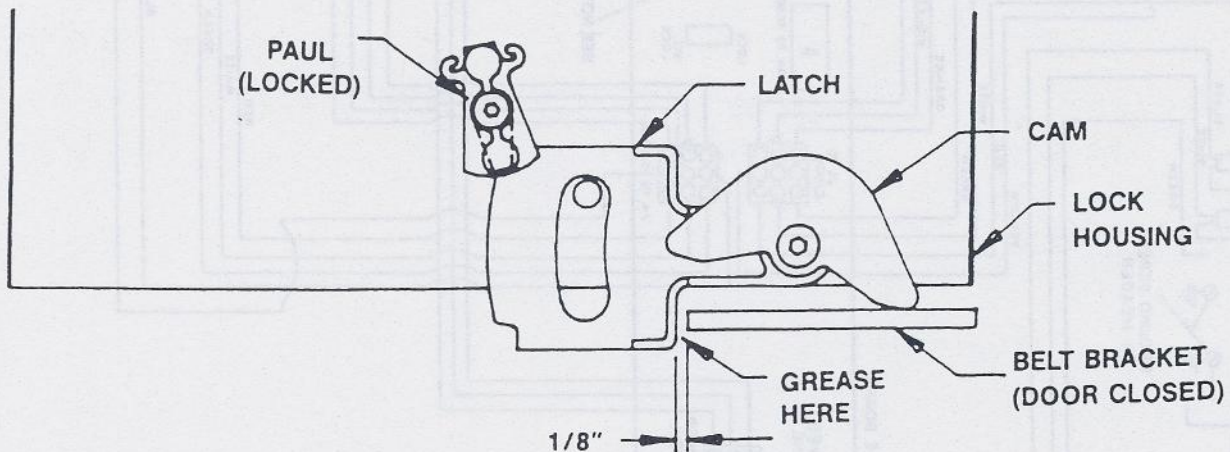
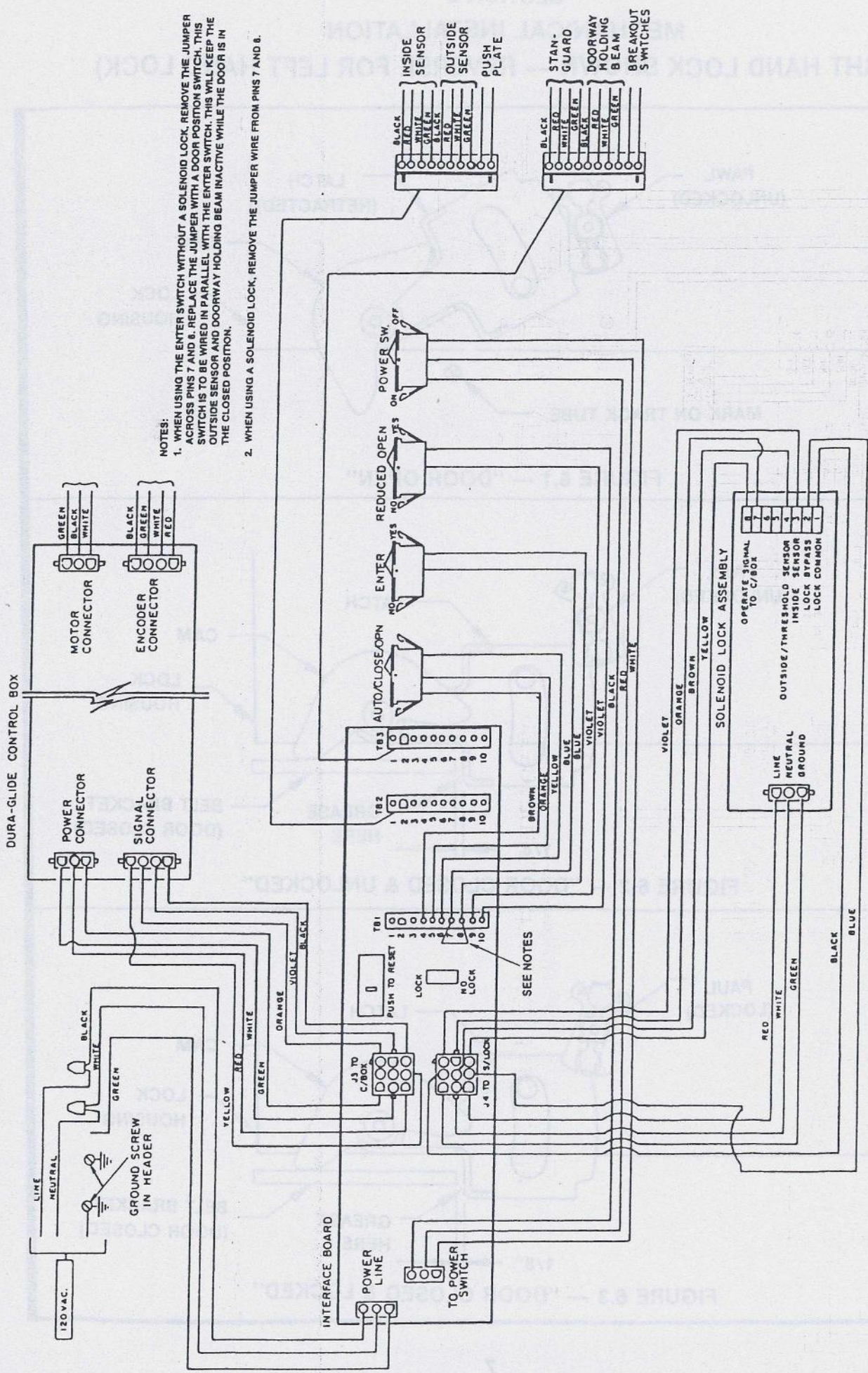

FIGURE 6.3 — "DOOR CLOSED & LOCKED"



NOTES:

1. WHEN USING THE ENTER SWITCH WITHOUT A SOLENOID LOCK, REMOVE THE JUMPER ACROSS PINS 7 AND 8. REPLACE THE JUMPER WITH A DOOR POSITION SWITCH. THIS SWITCH IS TO BE WIRED IN PARALLEL WITH THE ENTER SWITCH. THIS WILL KEEP THE OUTSIDE SENSOR AND DOORWAY HOLDING BEAM INACTIVE WHILE THE DOOR IS IN THE CLOSED POSITION.
2. WHEN USING A SOLENOID LOCK, REMOVE THE JUMPER WIRE FROM PINS 7 AND 8.

SOLENOID LOCK 516098 INTERFACE BOARD
(TYPICAL)

STANDARD WIRING 515128 INTERFACE BOARD (NO LOCK)

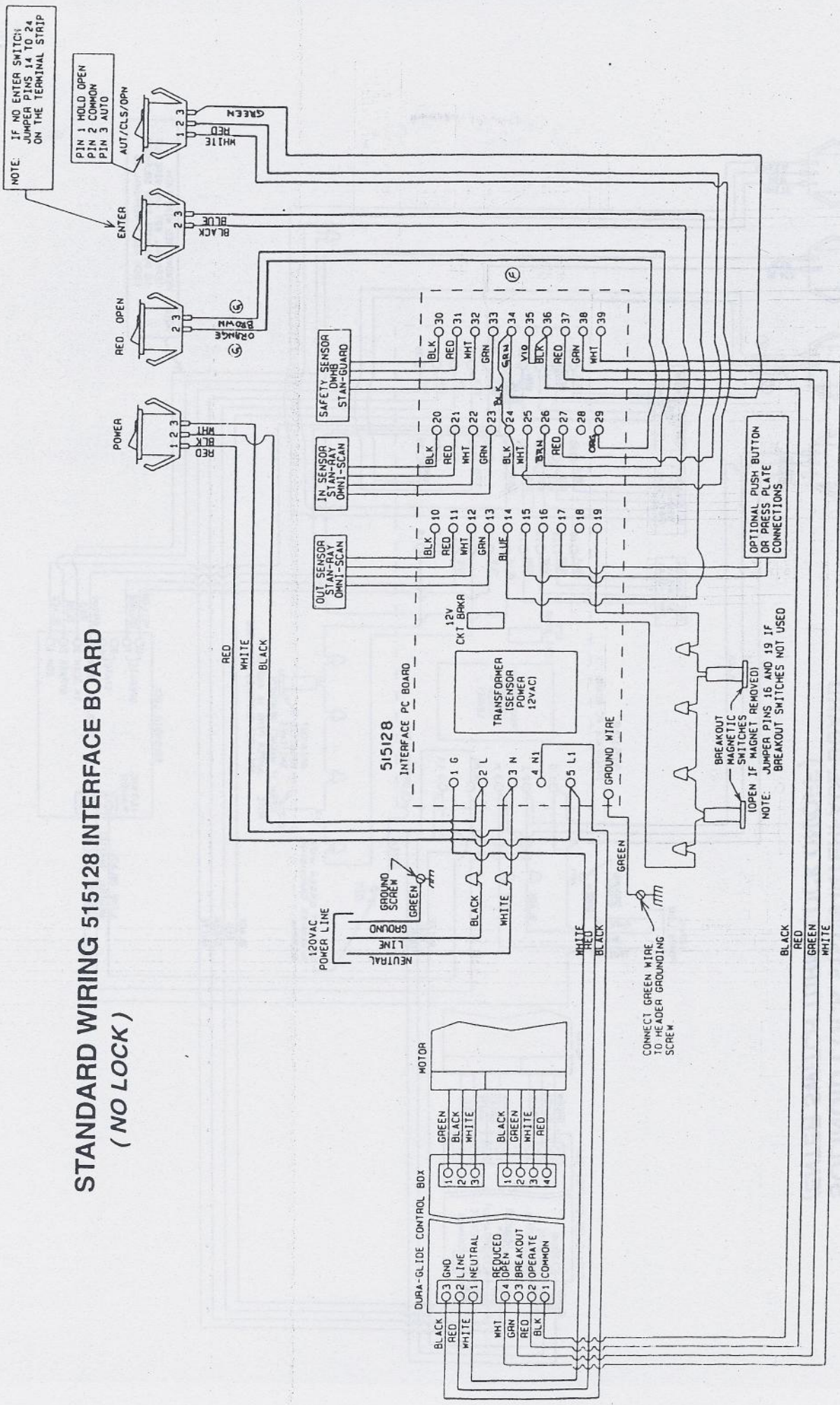

SOLINOID LOCK 515128 INTERFACE BOARD (ENTER SWITCH TURNS LOCK ON/OFF)

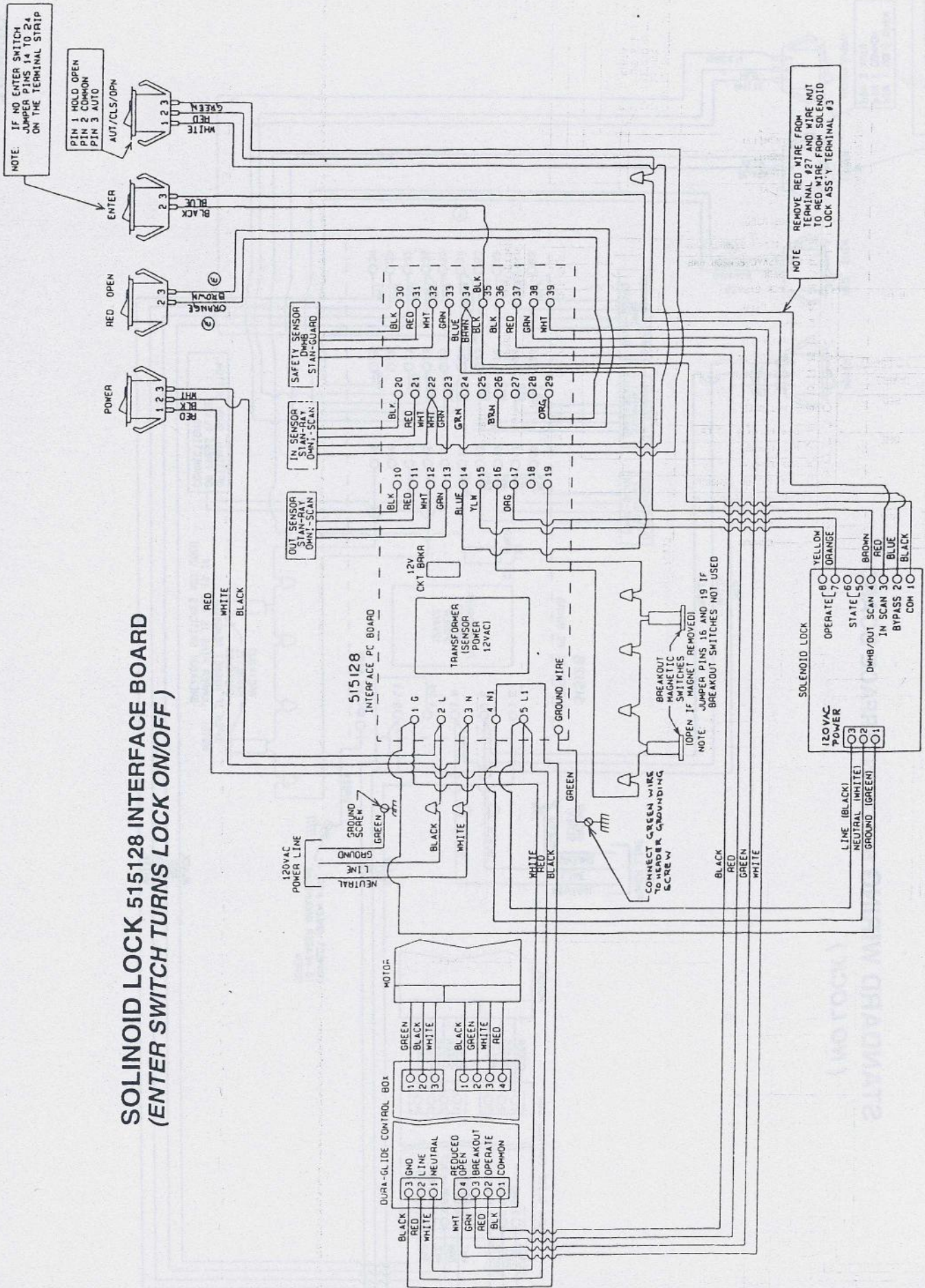

SOLENOID LOCK 515128 INTERFACE BOARD (TYPICAL)

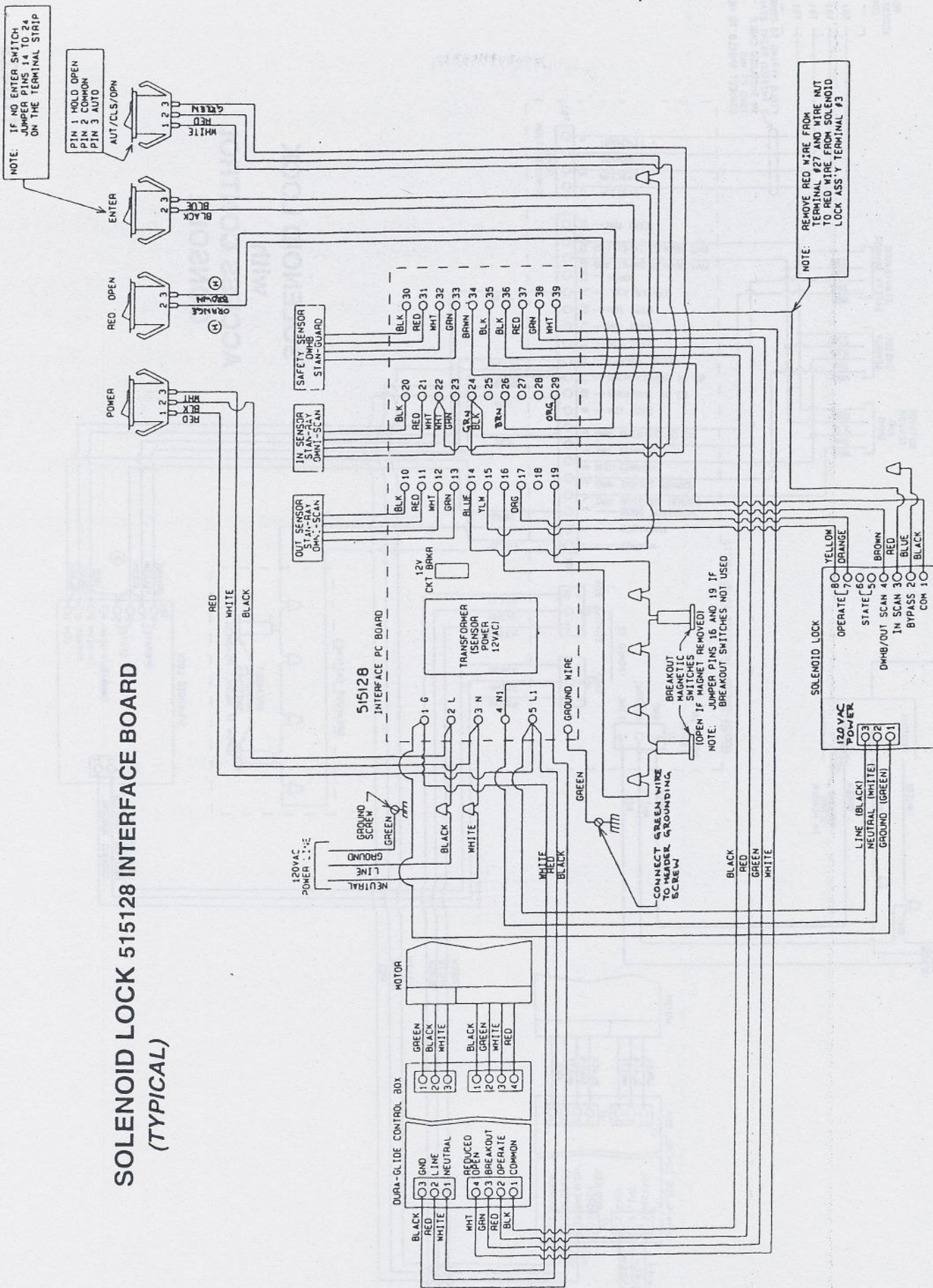

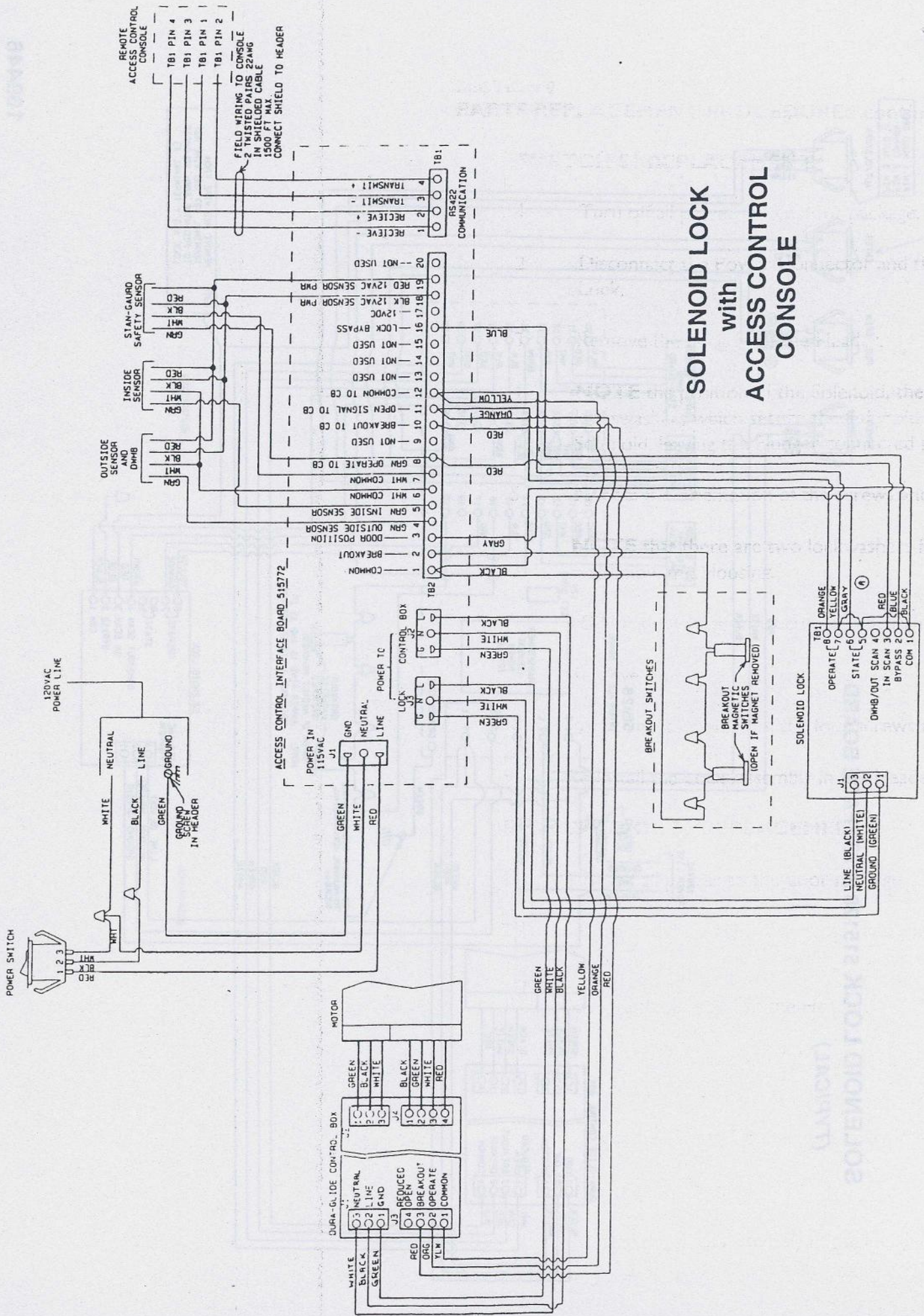

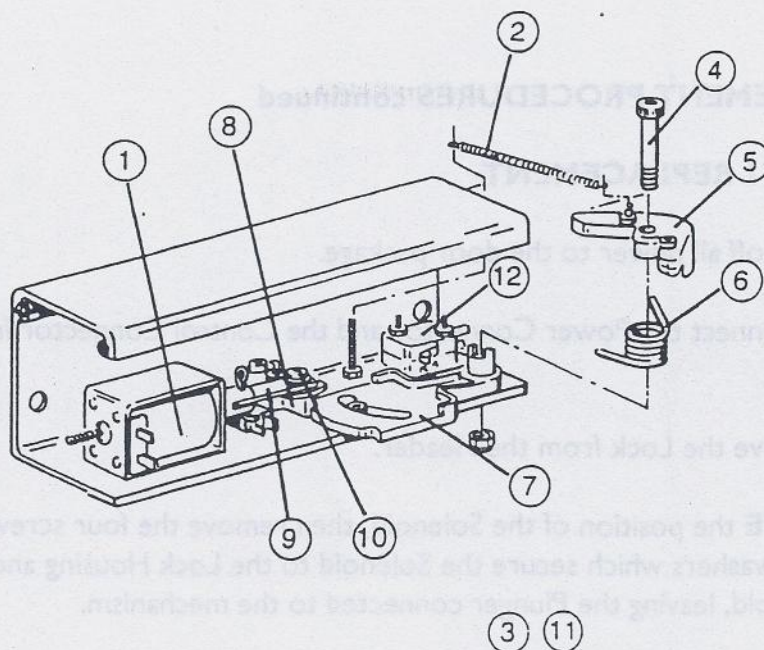

REF. NO.	PART NUMBER	DESCRIPTION
1	515230-2	SOLENOID
2	412397-1	SPRING
3	515305	HARNESS POWER
4	412401-2	SOCKET SCREW
5	515696	CAM
6	412395-R	SPRING TORSION
	412395-L	SPRING TORSION
7	515695	LATCH
8	515694	PAWL
9	412394	LINK
10	412401-1	SHOULDER SCREW
11	412404	HARNESS
12	412399	SWITCH

SOLENOID REPLACEMENT PROCEDURE

- 1 Turn off all power to the door package.
- 2 Disconnect the Power Connector and the Control Connector from the Solenoid Lock.
- 3 Remove the Lock from the Header.
- 4 **NOTE** the location of the Solenoid Mounting Holes and remove the four screws and lockwashers which secure the Solenoid to the Lock Housing, and remove the Solenoid by sliding it off of the Plunger. (Leave the Plunger connected to the mechanism. In most cases, it should not be necessary to replace the Plunger.)
- 5 Install the new Solenoid and secure with screws and lockwashers.
- 6 Re-install the Lock Assembly in the Header.

SECTION 9
PARTS REPLACEMENT PROCEDURES continued

SWITCH S1 REPLACEMENT

- 1 Turn off all power to the door package.
- 2 Disconnect the Power Connector and the Control Connector from the Solenoid Lock.
- 3 Remove the Lock from the Header.
- 4 **NOTE** the position of the Solenoid, then remove the four screws and lockwashers which secure the Solenoid to the Lock Housing and remove the Solenoid, leaving the Plunger connected to the mechanism.
- 5 **NOTE** the orientation of the screws and lockwashers which secure Switch S1.
NOTE that there are two lockwashers for each screw, one above the Switch and one below the Housing.
- 6 **NOTE** the wiring connections to Switch S1.
- 7 Remove Switch S1 and install the new Switch S1.
- 8 Install the Solenoid with the four screws and lockwashers.
- 9 Re-install the Lock Assembly in the Header.

SWITCH S2 OR S3 REPLACEMENT

- 1 Turn off all power to the door package.
- 2 Disconnect the Power Connector and the Control Connector from the Solenoid Lock.
- 3 Remove the Lock from the Header.
- 4 **NOTE** the orientation of the screws and lockwashers which secure Switches S2 and S3.
- 5 **NOTE** the Wiring Connections to Switches S1 and S3.
- 6 Install the Switches.
- 7 Re-install the Lock Assembly in the Header.

SECTION 9

PARTS REPLACEMENT PROCEDURES continued

REPLACEMENT OF LATCH, PAWL, OR CAM

- I Both the pawl and the latch & cam assembly are secured with shoulder screws which are threaded into the Housing and then further secured with a lockwasher and nut (or locknut).

NOTE - when installing the shoulder screws, be sure to first screw the screw fully down into the Housing and hold it in that position while tightening the external nut, to ensure firm seating of the shoulder bolts.

