

## iQ Controller Installation and Operation Manual 204144

INCLUDES INSTRUCTIONS FOR

**DURA-GLIDE™ 2000/3000, 5200/5300,  
DURA-GUARD™, DURA-STORM™, DURACARE™, \*5400-SERIES,  
\*PROCARE™ 8300A, AND DURACARE 7500A TL-FBO  
AUTOMATIC SLIDE DOOR SYSTEMS**

\*Refer to product-specific Installation Manuals for Wiring Diagrams as they contain the relevant system wiring.

Stanley Part Number 204144

REV B 01.2019

*Copyright 2019, Stanley Access Technologies, LLC.  
Prohibition on Copying: Any unauthorized reproduction, disclosure or distribution of copies by  
any person of any portion of this work may be a violation of copyright law of the United States  
of America and other countries, could result in the awarding of statutory damages of up to  
\$250,000 (17 USC 504) for infringement, and may result in further civil and criminal penalties.  
All rights reserved.*



All manuals can be found at  
[www.stanleymobileapps.com](http://www.stanleymobileapps.com)



# Table of Contents

<b>General Description</b> .....	<b>2</b>
Intended Use .....	2
Applicability .....	3
Prerequisites .....	3
Precautions .....	3
<b>Installation Instructions</b> .....	<b>3</b>
Installing the iQ Controller .....	3
<b>Wiring Instructions</b> .....	<b>3</b>
Evaluating Power Requirements .....	3
Connecting Main Power Wiring .....	4
Connecting Accessories (As Applicable).....	4
<b>Tune-In Instructions</b> .....	<b>4</b>
Handing for FIS Only.....	5
Tuning In the iQ Controller Using the Controller Pushbuttons .....	6
Tables.....	7
Final Tune-In Adjustments.....	18
<b>Attachments</b> .....	<b>19</b>
Attachment 1 - iQ Controls and Indicators .....	19
Attachment 2 - iQ System Wiring Diagram .....	21
Attachment 3 - iQ Terminal Block Connections TB1-TB7 .....	31
Attachment 4 - ANSI/BHMA and UL Compliance Requirements for Sliding Doors ..	32
Attachment 5 - Troubleshooting Aid .....	35
Attachment 6 - iQ Troubleshooting Aid .....	36
Attachment 7 - Fine Tuning Slide Doors .....	37

## 1 GENERAL DESCRIPTION

### Intended Use

This manual provides installation instructions, wiring instructions, and tune-in instructions for the iQ Controller. It includes instructions for Dura-Glide™ 2000/3000, 5200/5300, Dura-Guard™, Dura-Storm™, Dura-Max™ 5400-Series\*, ProCare™ 8300A\*, and DuraCare™ 7500A TL-FBO Automatic Slide door systems.

On Dura-Glide sliding doors, the iQ Controller replaces the MC521 and MC521Pro, or both the microprocessor control box and the interface board on older models. The door activation devices (SU-100 motion sensors, carpets, control mats, push plates, etc.), lock, function switch, doorway holding beams, and door position switches previously connected to the interface board must be connected to the iQ Controller.

Attachment 1 illustrates the iQ Controller controls and indicators. Attachment 2 illustrates system wiring for Dura-Glide series sliders.

This manual supports the hardware and firmware at the time of this released revision.

### Applicability

This manual is applicable to the Dura-Glide series sliding doors used on Dura-Glide™ 2000/3000, 5200/5300, Dura-Guard™, Dura-Storm™, Dura-Max™ 5400-Series, ProCare™ 8300A, and DuraCare™ 7500A TL-FBO Automatic Slide door systems.

Instructions for connecting optional accessories are not provided in this manual.

## Prerequisites

---

### Special Items Required:

- Stanley Access Technologies document No. 203957, “SU-100 Motion Sensor Installation and Operation” (if installed).
- SU-100 tune-in remote control (if SU-100 Motion Sensor is installed).
- Stanley Access Technologies document No. 203768, “Stanguard™ Threshold Sensor Installation and Operation” (if installed).
- Optex X Zone T or X Zone ST manufacturer’s installation and tune-in instructions (if installed).
- Hotron HR100 ST manufacturer’s installation and tune-in instructions (if installed).
- Bluetooth adapter or cable to connect compatible handheld device to iQ Controller.
- Degreaser.
- Instructions for any other device to be wired into the iQ Controller.

## Precautions

---

All ANSI/BHMA and UL Requirements in Attachment 4 must be met before the door is put into operation.

## 2 INSTALLATION INSTRUCTIONS

### Installing the iQ Controller

---

**NOTE:** This manual covers new door installations in which the iQ is factory-installed and wired.

## 3 WIRING INSTRUCTIONS

### Evaluating Power Requirements

---

- ENSURE power source is a dedicated 115 VAC, 50/60 Hz source with 20A circuit rating. If four operators are used, the source should have a 30A rating.
- ENSURE **no more than** four operators will be connected to one circuit.
- ENSURE power source is **not** shared with other equipment, i.e., cash registers, EAS systems, or other electromagnetic interference generators.

## Connecting Main Power Wiring

**⚠ Warning:** To prevent injury to personnel, incoming electrical power to the header must be de-energized before connecting electrical service to the control box.

**⚠ Warning:** All electrical wiring must conform to National Electrical Code Requirements.

1. **DE-ENERGIZE** incoming electrical power to header.
2. Refer to Attachment 2, and, using wire nuts, **CONNECT** incoming line, neutral, and ground wires to the controller power harness.
3. **IF** adhesive wire clamps will be used, **DE-GREASE** metal surfaces on inside of header cover where clamps will mount.
4. **SECURE** wiring to top of the header track tube, and **ENSURE** the following:
  - All wires are clear of belts and belt brackets.
  - Header cover opens and closes without interference.

## Connecting Accessories (As Applicable)

Refer to Attachments 2 and 3, and **CONNECT** any of the following subsystems to the iQ Controller:

- Function switch (rotary, rocker and “POWER” switch wiring).
- Stanguard™ threshold sensor.
- Doorway holding beam(s).
- Breakout switch.
- Solenoid lock.
- SU-100 motion sensor(s) wiring (refer to Stanley Document #203957).
- Optex X Zone T and X Zone ST Sensor(s) wiring.
- Push plate wiring.
- Door position switch closed contact (with door closed).
- Hotron HR100 ST Sensor(s) wiring.

## 4 TUNE-IN INSTRUCTIONS

**⚠ Warning:** The door path must be free of objects and remain clear until the First Install Sequence (FIS) is complete. During this sequence the sensors are inactive and the door has no SAFETY. To stop the door, **turn power off** or put the **doors into breakout**.

### NOTES:

1. **Tune-In:** The iQ Controller can be tuned-in using a handheld device or using the pushbutton switches located on the controller. Tune-in using a handheld device is the preferred method.
2. **Status Codes:** During normal operation, the digital display indicates status codes. The “UP” and “DOWN” pushbutton switches can be used to enter and display data values. The user interface values are shown in Tables 2 through 4.

3. **Solenoid Lock:** If a solenoid lock is installed with no lock circuit board (new style), set Lock Logic to the actual lock type (Fail Safe or Fail Secure). If a Fail Safe or Fail Secure Lock is being installed with a lock circuit board (old style), the Lock Logic must be set to Fail Secure.
4. **Handing (For purpose of FIS only):** Manually open door noting rotation of belt pulleys. If counter clockwise (CCW) use right hand during FIS. If clockwise (CW) use left hand during FIS. See figure below.
5. **FIS:** The first installation sequence (FIS) is used to perform the initial configuration. Upon completion of FIS, all setup parameters are stored in non-volatile memory. Subsequent power cycles will reload the configuration parameters that were configured during FIS.
6. Decimal points on digital display are encoder 1 signals. Rotating motor will cause decimal points to blink and appear to dim.
7. After changing values, the values must be saved in non-volatile memory by cycling the door to full open.

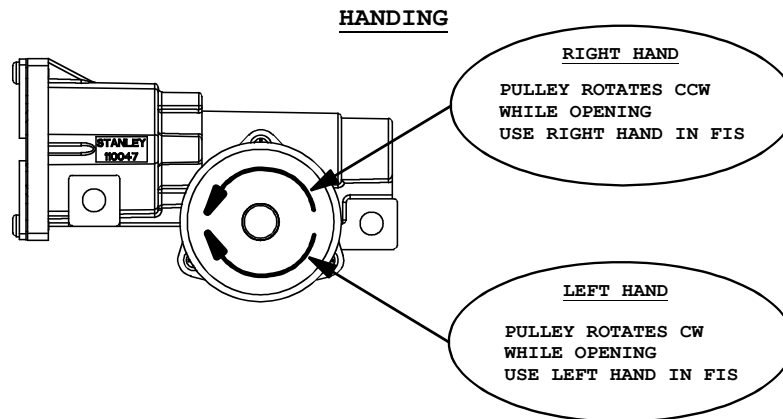

## Tuning In the iQ Controller Using the Controller Pushbuttons

---

1. To change the **INDEX** and **VALUE**:  
To show the **INDEX** press and hold **ENTER**, the current **INDEX** will display. Once **ENTER** is released, the display will show the **VALUE** of that **INDEX**. After 2.5 seconds, the display will return to the current status code.
2. To change the **INDEX**:  
Hold **ENTER** switch while pressing **UP** or **DOWN** to get desired **INDEX**.
3. To change a **VALUE**:
  - a. Unlock the keypad by setting index 99 to value 00.
  - b. After the desired **INDEX** is selected, release **ENTER** and **within 2.5 seconds** press **UP** or **DOWN** to get the desired **VALUE**. (If the **UP** or **DOWN** buttons are not pressed within 2.5 seconds of releasing the **ENTER** button, the display will change from the **VALUE** back to the **STATUS**.)
4. To display **STATUS CODE**:  
A few seconds after the **VALUE** is selected, the display indicates the **STATUS CODE**.
5. Refer to Tables 2 and 3 for a list of index setting descriptions and values. Read the descriptions entirely before performing each step. Check the **INDEX** and **VALUE** after each step.
6. To **STORE CHANGES** in permanent memory:  
Cycling door open one time will store changes.
7. To **LOCK** keypad:  
Lock keypad by setting index **99** to value **01** or by turning power **OFF** and then **ON**.
8. To **ACCESS** the door cycle counter function:
  - a. **Ensure** that the keypad is locked by setting index 99 to 01.
  - b. **Ensure** that the index is set to any index but 99.
  - c. **Press** the up or down key to access the door cycle counter.  
The display will show “**dc**” followed by four pairs of digits, followed by “**dc**”.

**Example:** If the Door Count was **12345678** cycles the controller will display “**dc**” “**12**” “**34**” “**56**” “**78**” “**dc**”.

**Table 1. FIS Procedure using Pushbuttons**

Step	Description	Display		
		Index	Value	Status Code
1	Set Function Switch to <b>Closed</b> .			
2	Turn power on.			
3	Unlock keypad.	99	00	00
4	Restart <b>FIS</b> .	96	01	A0
5	Select door type: Slide, <u>01</u> single motor or <u>02</u> dual motor.	00	01 (Single) 02 (Dual)	
6	Select Handing: <u>00</u> Right or <u>01</u> Left. <b>Manually open door and note rotation of belt pulleys.</b> <b>If counterclockwise (CCW) use right hand during FIS.</b> <b>If clockwise (CW) use left hand during FIS.</b>	01	00 (Right) 01 (Left)	A0
7	Accept <b>FIS</b> . Display will go to <b>A1</b> .	03	01	A1
8	Make changes: Function Switch <u>01</u> Rocker or <u>00</u> Rotary. The INDEX will start at 00.	11	01 (Rocker) 00 (Rotary)	A1
9	<b>Select Lock Logic:</b> Lock Logic, <u>00</u> = Fail Safe; <u>01</u> = Fail Secure; <u>02</u> = Fail Safe Dura-Max; <u>03</u> = Fail Secure Dura-Max. <b>NOTE:</b> For locks with circuit board, set to 01 Fail Secure. For locks with no circuit board, set to Fail Safe or Fail Secure.	07	Lock Logic: 00 = Fail Safe 01 = Fail Secure 02 = Fail Safe Dura-Max 03 = Fail Secure Dura-Max	
10	<b>Warning: During this sequence the sensors are inactive and the door has NO SAFETY. To stop the door, TURN POWER OFF or PUT THE DOOR INTO BREAKOUT.</b> <b>Function Switch:</b> Switch to <b>OPEN</b> , momentarily, then <b>CLOSED/ LOCKED</b> . The door opens fully, delays and then closes fully. The iQ displays A2 when FIS is completed.			A2
11	After FIS is complete it might be necessary to change index 11 (safety logic) and Index 20 (Safety Beam Type) to match the systems installed. Adjust any other index settings as needed (refer to Table 3 for options).			
12	Lock keypad.	99	01	00
13	Final Tune-In. Walk test doors to confirm compliance with applicable ANSI Standards and local codes.			

Copyright 2019, Stanley Access Technologies, LLC. All rights reserved. Reproduction in whole or in part without the express written permission of Stanley is prohibited.

01.25.2019

**Table 2. Index List**

Index	Description
0 - 99	Settings Values, see Table 3.
90 - 95	Reserved.
96	Command – Restart FIS. Entering “01” will cause FIS to restart.
97	Firmware – Entering “01” will display “FE” followed by two pairs of digits followed by “FE”. For example, if the firmware was 0609 the controller will display “FE” “06” “09” “FE”.
98	Command – Restart auto configuration. Entering “01” sets the Control Box to “A1” keeping all previous values and then re-learns the encoder count.
99*	Command – Lock. Entering “01” will lock all value inputs except this index. This prevents inadvertent changes to input values. Values may be unlocked by entering “00” in this index.

**Table 3. Settings**

Index	Min. Value	Max Value			Defaults	
					Single	Dual
0	1	99*	Open Speed	<p>Open Speed is the speed used during normal operation in the opening state (02).</p> <p>This speed is set to change how long it takes the door to open.</p> <p>This parameter sets the target speed setting. Other parameters like open torque, open startup torque, open startup length, and open acceleration as well as door properties like friction, door length, and door weight affect door speed.</p>	99	99
1	1	99*	Close Speed	<p>Close Speed is the speed used during normal operation in the closing state (07).</p> <p>This speed is set to change how long it takes the door to close.</p> <p>This parameter sets the target speed setting. Other parameters like Close Torque, Close Startup Torque, Close Startup Length, and Close Acceleration as well as door properties like friction, door length, and door weight affect door speed.</p>	35	25
2	1	99*	Open Check Speed	<p>Open Check Speed is the speed used during normal operation in the open check state (04) prior to arriving at full open.</p> <p>This speed is set to determine how fast the door arrives at full open after open speed.</p> <p>This parameter sets the target speed setting. Other parameters like open check torque, open acceleration, and open braking as well as door properties like friction, door length, and door weight affect door speed.</p>	10	10

**NOTE:** With the iQ Toolbox, the Max Values are 125.

**Table 3 Settings continued next page.**



**Table 3. Settings (continued)**

Index	Min Value	Max Value	Description		Defaults	
					Single	Dual
3	5	99	Open Check Length	Open Check Length is the percent of door length in which the door starts to slow down to open check speed.  This parameter typically is adjusted based on door weight and open speed setting.	40	25
4	5	99	Close Check Length	Close Check Length is the percent of door length in which the door starts to slow down to Close Check Speed.  This parameter typically is adjusted based on door weight and Close Speed setting.	15	15
5	1	99	Reduced Open Length	Reduced Open Length is the percent of door length from the full open position the door will stop at if in reduced open mode.	1	1
6	1	99	Hold Open Delay	Delay that the door stays open after all sensors have cleared (0 to 25 seconds).	15	15
7	0	3	Lock Logic	Select to choose desired Lock Logic. NOTE: Dura-Max 5400 logic is different and has its own two options: 00 = Fail Safe (unlocked when power is removed), 01 = Fail Secure (locked when power is removed), 02 = Dura-Max Fail Safe (unlocked when power is removed), 03 = Dura-Max Fail Secure (locked when power is removed).	1	1
8	1	99*	Open Torque	Open Torque is the torque used during normal operation following the end of open startup length.  This torque must be set to comply with BHMA/ANSI door force requirements.  This parameter sets the maximum current available to the motor which is directly proportional to the door force. This torque setting is used in conjunction with open speed.	40	45

Table 3 Settings continued next page.

Copyright 2019, Stanley Access Technologies, LLC. All rights reserved. Reproduction in whole or in part without the express written permission of Stanley is prohibited.

01.25.2019

**Table 3. Settings (continued)**

Index	Min Value	Max Value	Description		Defaults	
					Single	Dual
9	1	99	Close Torque	<p>Close Torque is the torque used during normal operation following the end of Close Startup Length.</p> <p>This torque must be set to comply with BHMA/ANSI door force requirements.</p> <p>This parameter sets the maximum current available to the motor which is directly proportional to the door force. This torque setting is used in conjunction with Close Speed.</p>	30	25
10	1	99	Close Check Torque	<p>Close Check Torque is the torque used during normal operation in close check state.</p> <p>This torque must be set to comply with BHMA/ANSI door force requirements.</p> <p>This parameter sets the maximum current available to the motor which is directly proportional to the door force. This torque setting is used in conjunction with close check speed.</p>	35	25
11	0	2	Function Switch Type	<p>00 = Double pole rotary 01 = Rocker 02 = ICU</p>	1	1
12	0	1	2S Operation;	<p>00 = 2S mode disabled / normal 01 = Push switch to open, push switch to close;</p>	0	0
13	1	60	Close Obstruction Time	<p>Close Obstruction Time is the amount of time in increments of 0.025s the door applies force when almost stopped or stopped when the controller indicates a state of "07".</p> <p>Before increasing this parameter, check mechanical issues, and speed and torque parameter settings.</p>	50	50
14	0	40	Open Acceleration	<p>Open Acceleration affects the rate at which the door gets to its target speed.</p> <p>This parameter is used when the door is lagging open speed; open startup torque and open startup length should be investigated prior to increasing.</p> <p>This parameter affects all open motion speeds: open speed, open check speed, open learn speed, as well as open braking.</p>	30	30

Copyright 2019, Stanley Access Technologies, LLC. All rights reserved. Reproduction in whole or in part without the express written permission of Stanley is prohibited.

**Table 3 Settings continued next page.**

**Table 3. Settings (continued)**

Index	Min Value	Max Value	Description		Defaults	
					Single	Dual
15	1	10	Open Braking	The Open Braking parameter adjusts how quickly the door slows down prior to check speed.  Increasing this parameter increases braking power.	8	8
16	0	40	Close Acceleration	Close Acceleration affects the rate at which the door gets to its target speed.  This parameter is used when the door is lagging close speed, close startup torque and close startup length should be investigated prior to increasing.  This parameter affects all close motion speeds: close speed, close check speed, close learn speed, as well as close braking.	20	20
17	1	10	Close Braking	The Close Braking parameter adjusts how quickly the door slows down prior to check speed.  Increasing this parameter increases braking power.	4	2
18	0	6	Delayed Egress	Special Locking Application. See the Delay Egress Instruction Manual for use. 00 = Off 01 = 15 sec delay 1 second nuisance 02 = 30 sec delay 1 second nuisance 03 = 15 sec delay 2 second nuisance 04 = 30 sec delay 2 second nuisance 05 = 15 sec delay 3 second nuisance 06 = 30 sec delay 3 second nuisance	0	0
19	0	5	Safety Logic	00 - Monitored 2 Sensors: Threshold zone control (the threshold zone is enabled and disabled by the iQ). 1 - Monitored 4 Sensors: Threshold zone control (the threshold zone is enabled and disabled by the iQ). 2 - Monitored StanGuard™: (not recommended for Telescopic doors). 3 - Monitored 2 sensors. 4 - Non-monitored sensors. 5 - Monitored 4 sensors.	2	2

**Table 3 Settings continued next page.**

Copyright 2019, Stanley Access Technologies, LLC. All rights reserved. Reproduction in whole or in part without the express written permission of Stanley is prohibited.

01.25.2019

**Table 3. Settings (continued)**

Index	Min Value	Max Value	Description	Defaults	
				Single	Dual
20	0	1	Hold Beam Type 00 - Non-monitored Hold Beam 01 - Monitored Hold Beam  Selects the hold beam type to be used for monitored or non-monitored applications.  For Monitored Hold Beams: Photobeam Pro or Optex OSC12CT refer to wiring diagrams per application.	1	1
21	1	50	Lock Delay  This allows the lock to mechanically unlock before door motion. Lock Delay in 0.1 second increments.	1	1
22	0	99	Open Stop Distance  Distance from full open that the door will stop. This will be in 0.25" increments.	4	4
23	1	99	Close Check Speed  Close Check Speed is the speed used during normal operation in the close check state (09) prior to arriving at full closed.  This speed is set to determine how fast the door arrives at full closed after close speed.  This parameter sets the target speed setting. Other parameters like close check torque, close acceleration, and close braking as well as door properties like friction, door length, and door weight affect door speed.	8	8
24	0	1	Access Control Pro Enabled  Inside sensor lockout function. 00= OFF 01= ON  When set to 01-On, the interior activation input is inhibited if the exterior activation input is active. Activation override can be accomplished through TB2 pin 9 and 10.	0	0
25	0	5	Close Press  Close Press affects how the doors press together at full closed. If the value selected is 0, the door does not press at the closed position. A value of 1 will have a softer release of motor energy and a value of 5 will be a quicker release.	2	2
27	1	99	Lock Release Torque  Lock Release Torque is the torque used on lock release state. A closed position switch is required, connected to TB-5.  This parameter sets the maximum current available to the motor which is directly proportional to the door force.	20	20
28	1	60	Close Check Obstruction Time  Close Check Obstruction Time is the amount of time in increments of 0.025s the door applies force when almost stopped or stopped when the controller indicates a state of "09".  Before increasing this parameter, check mechanical issues, and speed and torque parameter settings.	50	50

Copyright 2019, Stanley Access Technologies, LLC. All rights reserved. Reproduction in whole or in part without the express written permission of Stanley is prohibited.

01.25.2019

**Table 3. Settings (continued)**

Index	Min Value	Max Value	Description		Defaults	
					Single	Dual
31	1	99*	Close Learn Speed	<p>Close Learn Speed is the speed used on power up, during FIS and after an obstruction. The controller display may indicate either 07 or 09 as a door state and still use Close Learn Speed based on the conditions listed prior.</p> <p>This speed is typically set higher than check speed, to allow faster door motion when not in the check zones, but still slower door motion than normal operation.</p> <p>This parameter sets the target speed setting. Other parameters like close learn torque and close acceleration as well as door properties like friction, door length, and door weight affect door speed.</p>	20	20
32	1	99	Close Learn Torque	<p>Close Learn Torque is the torque used on power up, during FIS, after an obstruction.</p> <p>This torque must be set to comply with ANSI/BHMA door force requirements.</p> <p>This parameter sets the maximum current available to the motor which is directly proportional to the door force. This torque setting is used in conjunction with Close Learn Speed.</p>	30	25
33	0	99	Close Startup Length	<p>Close Startup Length is the percent of door length in which Close Startup Torque parameter is used. These parameters are used to overcome friction encountered at the beginning of close door motion.</p> <p>This parameter should be set as low as possible to ensure reliable operation.</p>	0	0
35	1	99	Close Startup Torque	<p>Close Startup Torque is the torque used when entering the closing state (07). It is used for a configurable door length (determined by the Close Startup Length parameter). After this door length, the torque setting will revert to the Close Torque.</p> <p>This torque should be set greater than Close Torque to ensure that the controller can start door motion, overcome static friction, and avoid obstructions.</p> <p>This torque must be set to comply with ANSI/BHMA door force requirements.</p> <p>This parameter sets the maximum current available to the motor which is directly proportional to the door force.</p>	35	25

**Table 3 Settings continued next page.**

**Table 3. Settings (continued)**

Index	Min Value	Max Value	Description		Defaults	
					Single	Dual
36	1	60	Open Check Obstruction Time	<p>Open Check Obstruction Time is the amount of time in increments of 0.025s the door applies force when almost stopped or stopped when the controller indicates a state of "04".</p> <p>Before increasing this parameter, check mechanical issues, and speed and torque parameter settings.</p>	50	50
37	1	99	Open Check Torque	<p>Open Check Torque is the torque used during normal operation in open check state.</p> <p>This torque must be set to comply with ANSI/BHMA door force requirements.</p> <p>This parameter sets the maximum current available to the motor which is directly proportional to the door force. This torque setting is used in conjunction with open check speed.</p>	40	40
39	1	99*	Open Learn Speed	<p>Open Learn Speed is the speed used on power up, during FIS, after an obstruction, and return from breakout. The controller display may indicate either 02 or 04 as a door state and still use Open Learn Speed based on the conditions listed prior.</p> <p>This speed is typically set higher than check speed, to allow faster door motion when not in the check zones, but still slower door motion than normal operation.</p> <p>This parameter sets the target speed setting. Other parameters like open learn torque, and open acceleration as well as door properties like friction, door length, and door weight affect door speed.</p>	25	25
40	1	99	Open Learn Torque	<p>Open Learn Torque is the torque used on power up, during FIS, after an obstruction, and return from breakout.</p> <p>This torque must be set to comply with ANSI/BHMA door force requirements.</p> <p>This parameter sets the maximum current available to the motor which is directly proportional to the door force. This torque setting is used in conjunction with open learn speed.</p>	48	25
41	1	60	Open Obstruction Time	<p>Open Obstruction Time is the amount of time in increments of 0.025s the door applies force when almost stopped or stopped when the controller indicates a state of "02".</p> <p>Before increasing this parameter, check mechanical issues, and speed and torque parameter settings.</p>	50	50

**Table 3 Settings continued next page.**

**Table 3. Settings (continued)**

Index	Min Value	Max Value	Description		Defaults	
					Single	Dual
42	0	99	Open Startup Length	<p>Open Startup Length is the percent of door length in which open startup torque parameter is used. These parameters are used to overcome friction encountered at the beginning of open door motion.</p> <p>This parameter should be set as low as possible to ensure reliable operation.</p>	15	15
44	1	99	Open Startup Torque	<p>Open Startup Torque is the torque used when entering the opening state (02) and recycles. It is used for a configurable door length (determined by the Open Startup Length parameter). After this door length, the torque setting will revert to the Open Torque.</p> <p>This torque should be set greater than Open Torque to ensure that the controller can start door motion, overcome static friction, and avoid obstructions.</p> <p>This torque must be set to comply with ANSI/BHMA door force requirements.</p> <p>This parameter sets the maximum current available to the motor which is directly proportional to the door force.</p>	85	85
45	0	99	Recycle Speed	<p>Recycle Speed is the percent of open speed that is used when recycling in the open check or open braking zone.</p>	30	20
46	0	50	Lock Release Time	<p>The amount of time (seconds) that the door will press closed before going open when the lock needs to release at the closed position. The value zero disables the lock release. A closed position switch is required, connected to TB-5.</p>	0	0
47	0	4	Fire Alarm Mode	<p>Allows a normally closed contact to force the door open or closed slowly, upon contact opening.</p> <p>Used in conjunction with Configurable I/O parameter.</p> <p>Options 00 to 04 are minimum and maximum values:                      00 = Disabled,                      01 = Open,                      02 = Close,                      03 = Open with Retry,                      04 = Close with Retry.</p> <p>After an obstruction, retry modes (03 and 04) will retry with short delay.</p>	0	0

**Table 3 Settings continued next page.**

Copyright 2019, Stanley Access Technologies, LLC. All rights reserved. Reproduction in whole or in part without the express written permission of Stanley is prohibited.

01.25.2019

**Table 3. Settings (continued)**

Index	Min Value	Max Value	Description			Defaults		
						Single	Dual	
48	0	3	IO configuration			0	0	
			TB2-5	TB2-7	TB2-9			
	00 (Default)	1 way / 2 way	Reduced	Access Control Pro activation override (highest priority when selected).				
				4 Monitored Sensors (when selected).				
				Delay egress reset (default).				
	01	1 way / 2 way	Reduced	Fire Alarm.				
	02	1 way / 2 way	Fire alarm	Access Control Pro activation override (highest priority when selected).				
				4 Monitored Sensors (when selected).				
				Delay egress reset (default).				
	03	Fire alarm	Reduced	Access Control Pro activation override (highest priority when selected).				
			4 Monitored Sensors (when selected).					
			Delay egress reset (default).					
<b>IO Configuration Parameter Description</b>								
Allows the Fire Alarm to be used instead of functions normally used with the selected input:								
0 = Standard Functions (NO Fire Alarm Input).								
1 = Fire Alarm Input is TB2-9 (Removes Functions: Access Control Pro activation override, Delayed Egress Reset, and 4 Monitored Sensor capability).								
2 = Fire Alarm Input is TB2-7 (Removes Reduced Open function).								
3 = Fire Alarm Input is TB2-5 (Removes One-way function).								
Index	Min Value	Max Value	Descriptions			Defaults		
						Single	Dual	
49	0	99	Open Power Assist Torque	This parameter sets the current to the motor which is used to make the door feel easier to move open when in "Manual" mode. This value should be set only as high as is needed to reduce the force required to move the door. Setting this value too high can cause the door to move by itself. Only available when index 11 is set to 02-ICU.			60	60
50	0	99	Close Power Assist Torque	This parameter sets the current to the motor which is used to make the door feel easier to move closed when in "Manual" mode. This value should be set only as high as is needed to reduce the force required to move the door. Setting this value too high can cause the door to move by itself. Only available when index 11 is set to 02-ICU.			50	50

01.25.2019 Copyright 2019, Stanley Access Technologies, LLC. All rights reserved. Reproduction in whole or in part without the express written permission of Stanley is prohibited.



**Table 4. Status Codes**

Status Code	Description	Remediation IF Necessary
00	Normal operation—All OK	
20	Breakout	
33	System error	See attachment 7
34	Internal communication error – Type 1	See attachment 7
35	Motor drive failure	Replace controller
36	Internal communication error – Type 2	See attachment 7
0b	Obstruction	
A0	First Installation Sequence (FIS)	
A1	Auto-configuration sequence	
A2	Auto-configuration confirmation sequence	
b1	Encoder error > cable failure	Verify magnet/encoder pair
b2	Encoder mismatch > wrong encoder/magnet	Verify magnet/encoder pair
b3	Encoder fault > wrong encoder/magnet or cable failure	Verify magnet/encoder pair
bE	Blocked egress	
c1	Position learn error	
Ld	Lock down (shear lock energized)	
db	Output control	See Attachment 6, Sheet 2 of 2
dc	Display door cycle counter	
dE	Delayed egress	
d0	Free egress	
E2	Door held open by any sensor input other than the Hold Open switch on TB2-1.	
E3	Door length error	Re-do First Installation Sequence (FIS)
E4	Presence sensor monitoring failure	Verify sensor wiring and safety logic setting
E5	Motor drive failure	
F0	Inside monitored sensor failure	Verify sensor wiring and safety logic setting
F1	Outside monitored sensor failure	Verify sensor wiring and safety logic setting
F2	Upper Monitored Photo Beam failure	Check transmitter, receiver, and hold beam type
F3	Lower Monitored Photo Beam failure	Check transmitter, receiver, and hold beam type
F6	Inside (2) monitored sensor failure	Verify sensor wiring and safety logic setting
F7	Outside (2) monitored sensor failure	Verify sensor wiring and safety logic setting
ho	Door held open	Check sensors and hold beam type
FA	Fire Alarm Active	
uL	Unlocked delay egress	

Copyright 2019, Stanley Access Technologies, LLC. All rights reserved. Reproduction in whole or in part without the express written permission of Stanley is prohibited.

01.25.2019

**Table 5. Door States**

Door State	Description
00	Door State is Closed
02	Door State is Opening
04	Door State is in Open Check
06	Door State is Full Open
07	Door State is Closing
09	Door State is in Close Check
10	Open Assist (manual mode door state)
11	Close Assist (manual mode door state)
12	Close Assist (manual mode door state)
14	Door Fault
15	Door State is in Open Stop
16	Door State is in Obstruction while Closing
17	Door State is in Close Press
19	Lock Release (door state)
<p><b>NOTE:</b> If the current status code is “Normal operation—All OK”, the iQ will show the current door state. Otherwise, the iQ alternates between showing the current status code and the door state.</p>	

## Final Tune-In Adjustments

1. Refer to ANSI/BHMA A156.10, “Standard for Power Operated Pedestrian Doors,” and attachment 4 and DETERMINE ANSI and UL door operating requirements.
2. IF Stanguard™ threshold sensor is installed, refer to Stanley Access Technologies document No. 203768, “Stanguard™ Threshold Sensor Installation and Operation,” and TUNE-IN Stanguard™ threshold sensor. Ensure that the JP301 Jumper is properly installed for StanGuard™ Sensors.
3. IF SU-100 motion sensor(s) are installed, refer to Stanley Access Technologies document No. 203957, “SU-100 Motion Sensor Installation and Operation,” and TUNE-IN SU-100 motion sensor(s).
4. IF Optex X Zone T or X Zone ST Sensors are installed, refer to the manufacturer’s installation and tune-in instructions.
5. If Hotron HR100 ST sensors are installed, refer to the manufacturer’s instructions.
6. After all changes have been made, cycle the door to have the settings stored in Non-Volatile memory. Then turn power OFF and then back ON to ensure that all of the settings are permanently stored.
  - Verify that the correct Safety Logic has been selected for Sensor Monitoring and that the JP301 is in the correct position.
  - DO NOT remove JP301 when Stanguard™ is installed. X Zone T, X Zone ST and HR100 ST monitored sensors require JP301 to be removed.
7. This step only applies to the Stanley Automatic ICU series doors: Refer to ANSI/BHMA A156.38, “American National Standard for Low Energy Power Operated Sliding and Folding Doors” and Attachment 4 (Page 3 of 3) and determine ANSI and IBC-2018 door operating requirements.

Copyright 2019, Stanley Access Technologies, LLC. All rights reserved. Reproduction in whole or in part without the express written permission of Stanley is prohibited.

01.25.2019

## Attachment 1 iQ Controls and Indicators (Sheet 1 of 2)

**NOTE: See next page for indicators and descriptions**

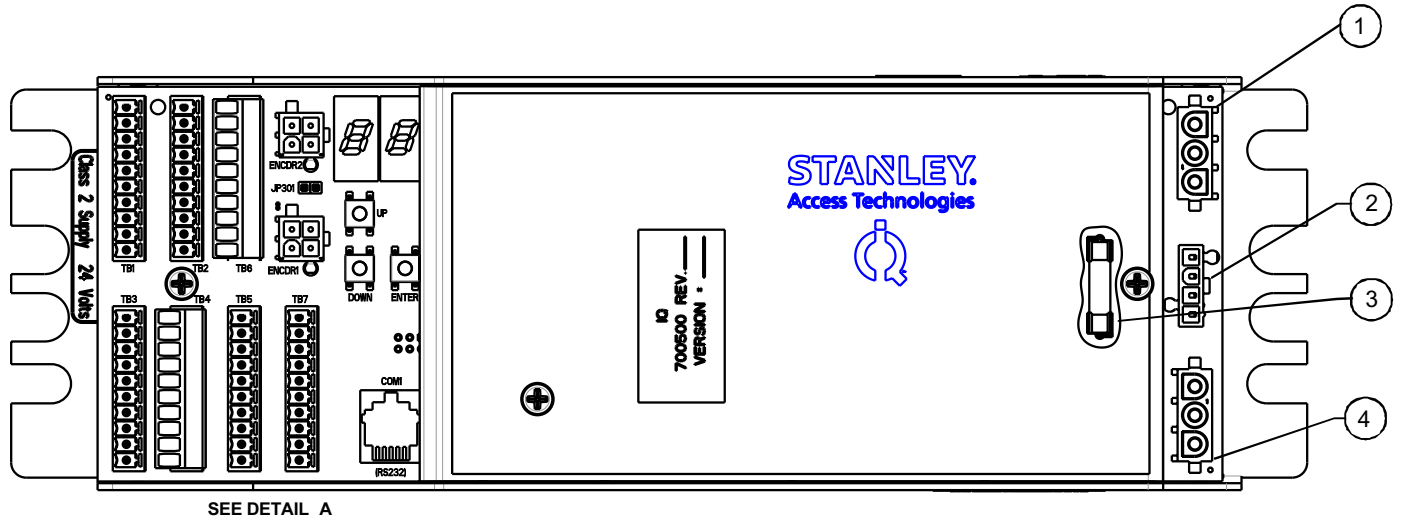

SEE DETAIL A

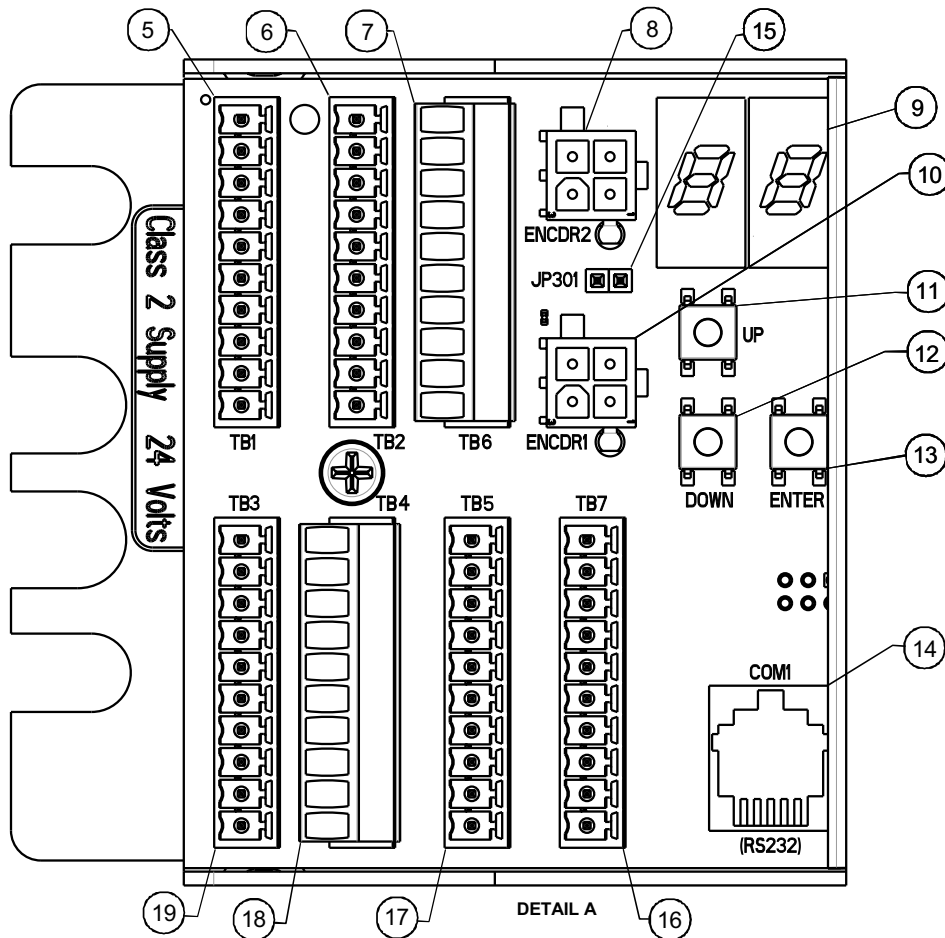

DETAIL A

**Attachment 1  
iQ Controls and Indicators  
(Sheet 2 of 2)**

ITEM	CONTROL/INDICATOR	DESCRIPTION
1	Motor 2 Connector	Motor No. 2 connector.
2	Power Connector	Connection point for incoming line, neutral, and common power wiring.
3	Fuse	Controller fuse-- 5 Amp, 250V.
4	Motor 1 Connector	Motor No. 1 connector.
5	Terminal Block Connector TB1	Connection point for 24V power supply and solenoid lock.
6	Terminal Block Connector TB2	Connection point for function switch (rotary or rocker) and Fire Alarm input.
7	Terminal Block Connector TB6	Push plate outside. Monitored Photo Beam and Test output.
8	Encoder 2 Connector	Encoder # 2 Connector.
9	Two Digit Display	Displays Controller Status. Also serves as the display for tune-in by pushbutton switches and indicates encoder movement. High resolution encoder may be dim.
10	Encoder 1 Connector	Connection point for motor encoder No. 1.
11	Up Pushbutton Switch	Used for manual setup and tuning of door when handheld is not available.
12	Down Pushbutton Switch	Used for manual setup and tuning of door when handheld is not available.
13	Enter Pushbutton Switch	Used for manual setup and tuning of door when handheld is not available.
14	RS232	RS232 connector. Connection point for Bluetooth harness.
15	Jumper JP301	Keep jumper installed for Stanguard™ installations. See wiring diagrams to determine when to remove JP301 for monitored sensor installations.
16	Terminal Block Connector TB7	Connection for ECO Pro.
17	Terminal Block Connector TB5	Side screen sensor, door position switch.
18	Terminal Block Connector TB4	Connection point for <b>INSIDE / OUTSIDE</b> sensor and push plate.
19	Terminal Block Connector TB3	Connection point for Stanguard™, safety sensor and breakout switch. Using jumper wires across TB3 terminals 1 to 5 and 2 to 6, internal 24 VDC supplies power to multiple external sensors.

Copyright 2019, Stanley Access Technologies, LLC. All rights reserved. Reproduction in whole or in part without the express written permission of Stanley is prohibited.

01.25.2019

## Attachment 2 iQ System Wiring Diagram (Sheet 1 of 10)

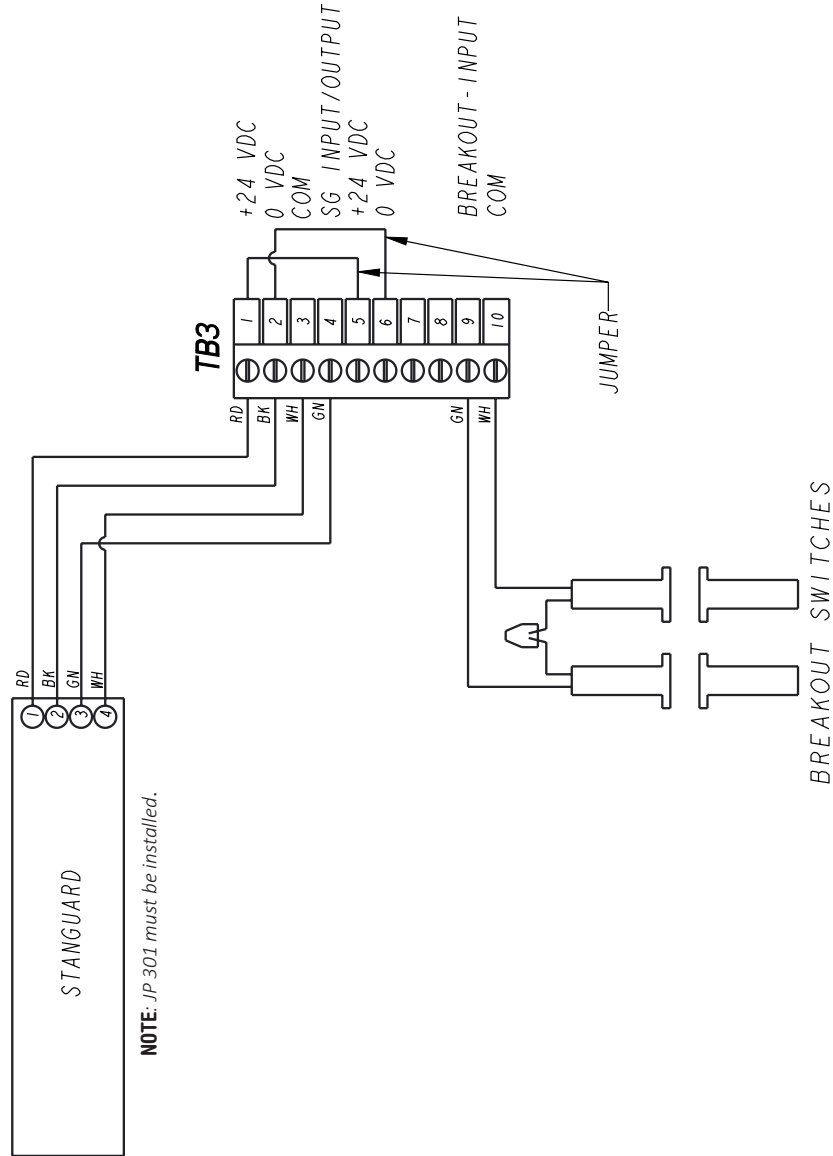

## Attachment 2 iQ System Wiring Diagram (Sheet 2 of 10)

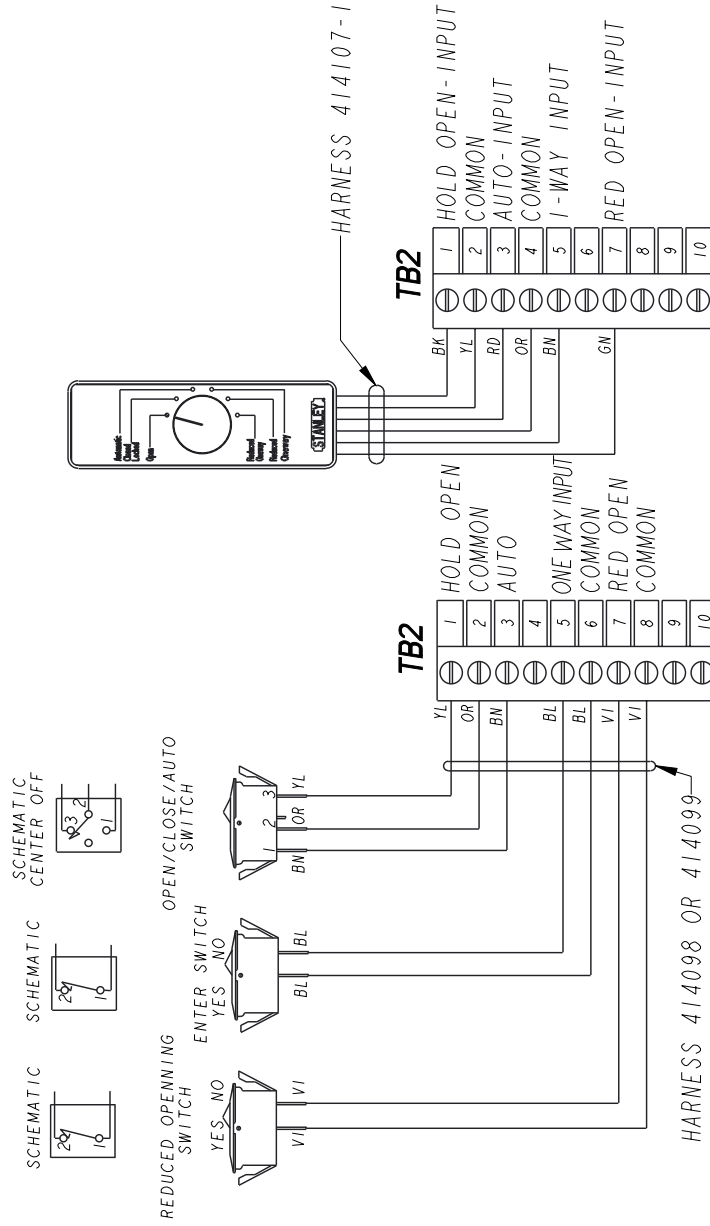

## Attachment 2 iQ System Wiring Diagram (Sheet 3 of 10)

SEE NEXT PAGE

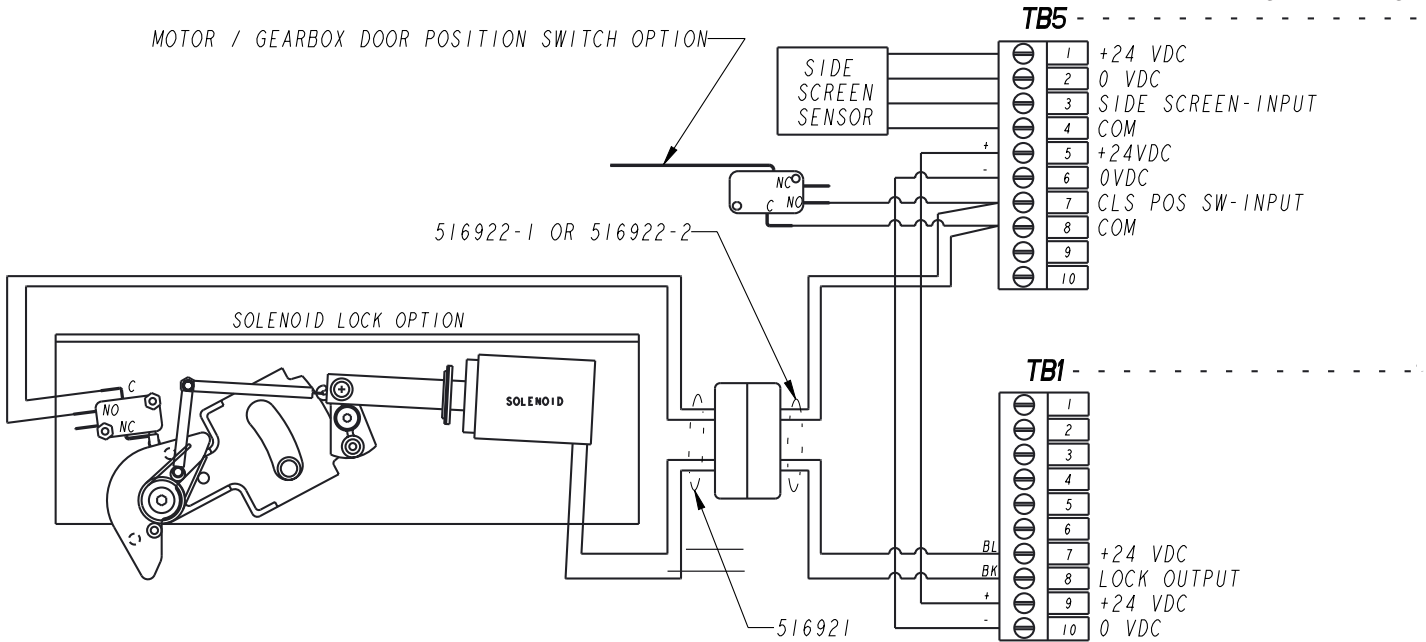

OR

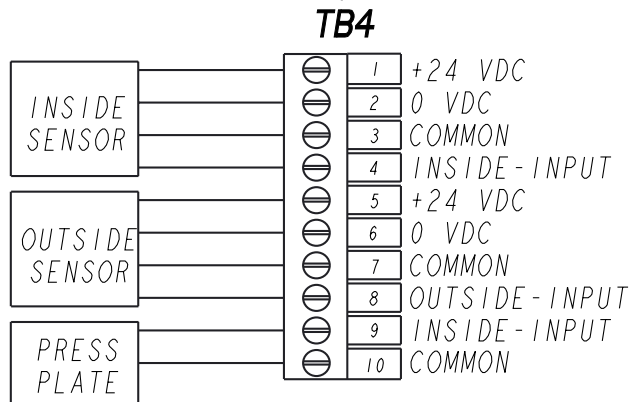

**NON-MONITORED**

Copyright 2019, Stanley Access Technologies, LLC. All rights reserved. Reproduction in whole or in part without the express written permission of Stanley is prohibited.

01.25.2019

## Attachment 2 iQ System Wiring Diagram (Sheet 4 of 10)

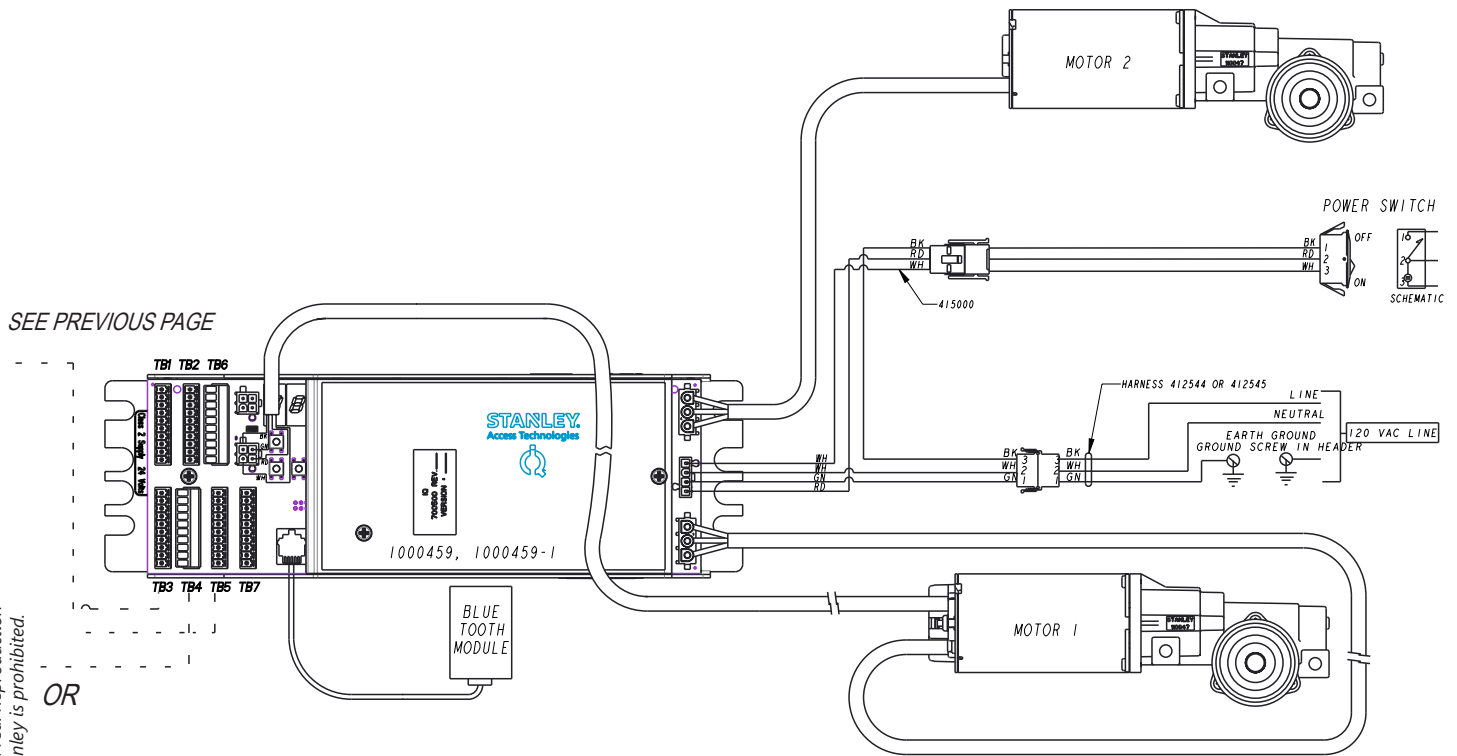

Copyright 2019, Stanley Access Technologies, LLC. All rights reserved. Reproduction in whole or in part without the express written permission of Stanley is prohibited.

01.25.2019



## Attachment 2 iQ System Wiring Diagram (Sheet 5 of 10)

### PHOTO BEAM PRO HOLDING BEAM/ STANLEY PHOTO BEAM

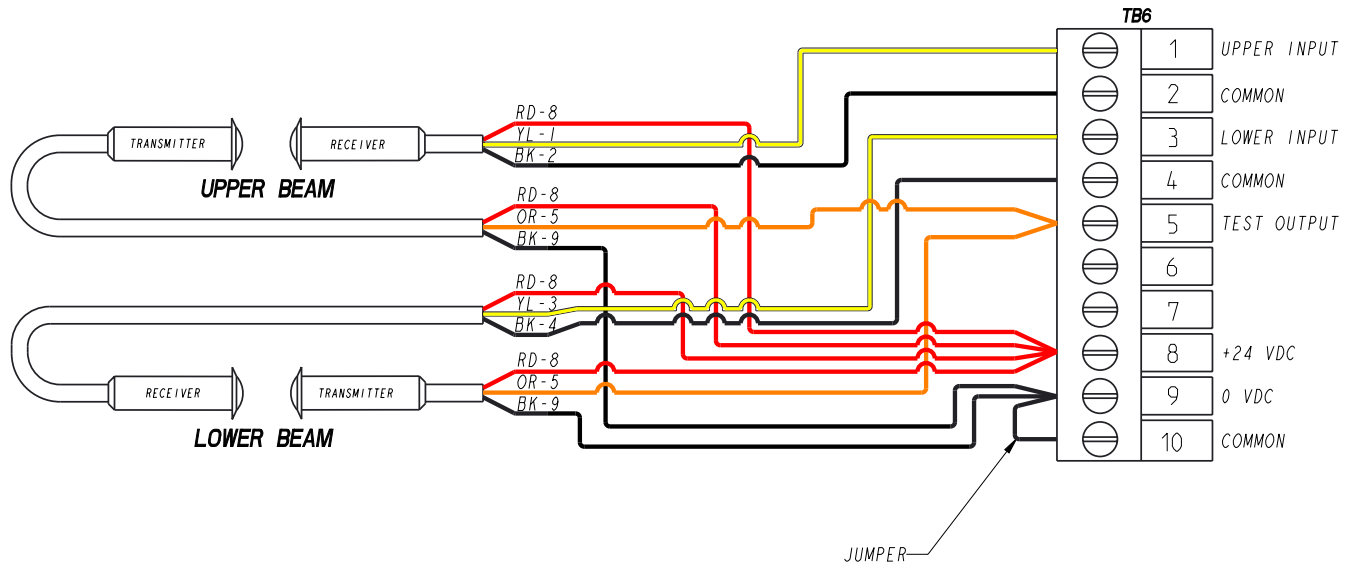

On the iQ: Set INDEX 20 to VALUE 01 (Monitored Beam).

TB6	COLOR	DUAL HOLDING BEAM WIRING
1	YL	OUTPUT UPPER RECEIVER
2	BK	(-) UPPER RECEIVER
3	YL	OUTPUT LOWER RECEIVER
4	BK	(-) LOWER RECEIVER
5	OR	TRANSMITTER CONTROL LOWER AND UPPER
6	--	NO CONNECTION
7	--	NO CONNECTION
8	RD	(+) ALL RECEIVERS AND TRANSMITTERS
9	BK	(-) LOWER AND UPPER TRANSMITTERS, JUMPER TO TB6-10
10	BK	JUMPER FROM TB6-9

## Attachment 2 iQ System Wiring Diagram (Sheet 6 of 10)

### OPTEX OS-12C T DOORWAY HOLDING BEAM

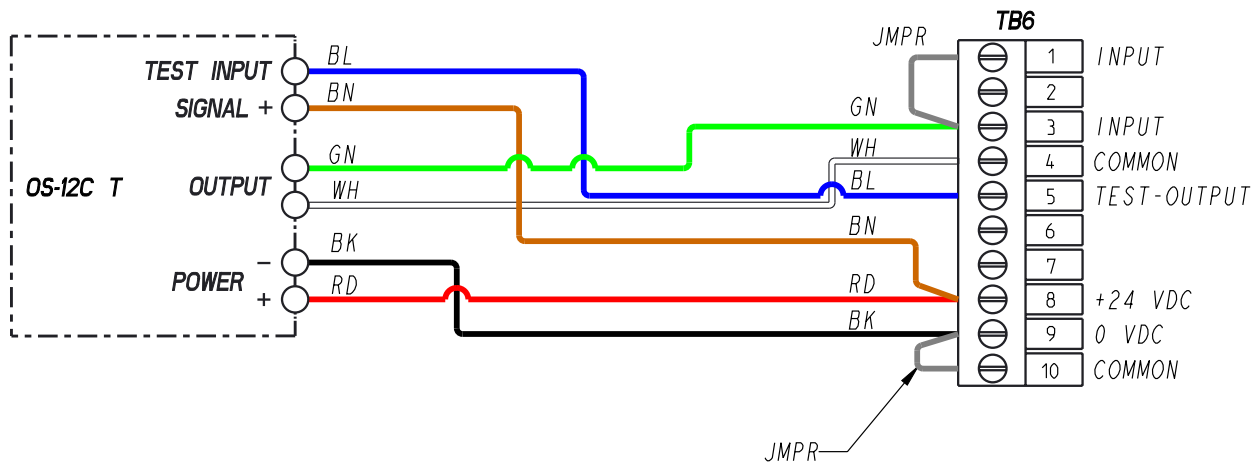

Program the OS-12 CT set to "D" - Active High / N.C.  
On the iQ: Set INDEX 20 to VALUE 01 (Monitored Beam).

## Attachment 2 iQ System Wiring Diagram (Sheet 7 of 10)

### PHOTO BEAM PRO BREAKOUT BEAM

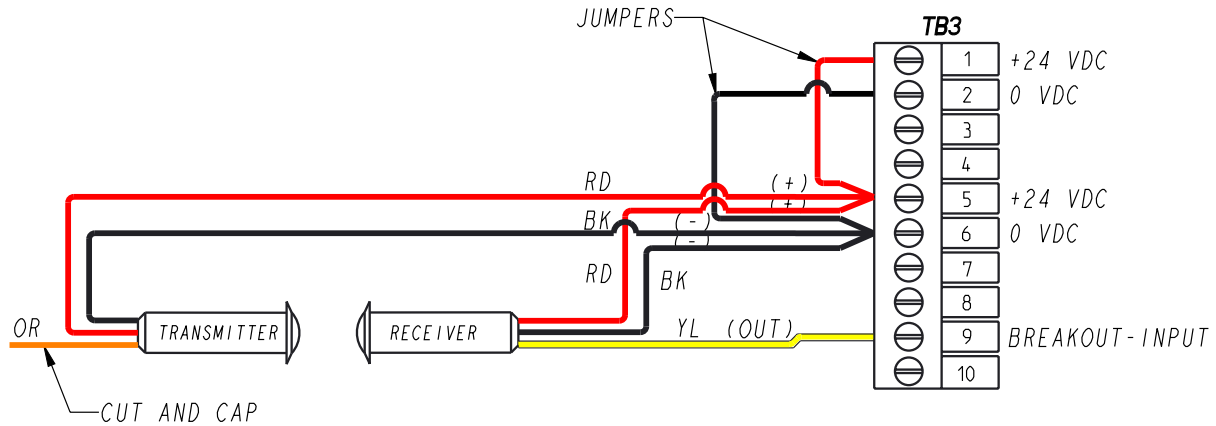

TB3	COLOR	PHOTO BEAM PRO BREAKOUT BEAM
1	RD	JUMPER FROM TB3-5
2	BK	JUMPER FROM TB3-6
3	--	NO CONNECTION
4	--	NO CONNECTION
5	RD	JUMPER FROM TB3-1, (+) RECEIVER AND TRANSMITTER
6	BK	JUMPER FROM TB3-2, (-) RECIEVER AND TRANSMITTER
7	--	NO CONNECTION
8	--	NO CONNECTION
9	YL	OUTPUT RECEIVER
10	--	NO CONNECTION

## Attachment 2 iQ System Wiring Diagram (Sheet 8 of 10)

### X ZONE T & ST 2 MONITORED SENSORS

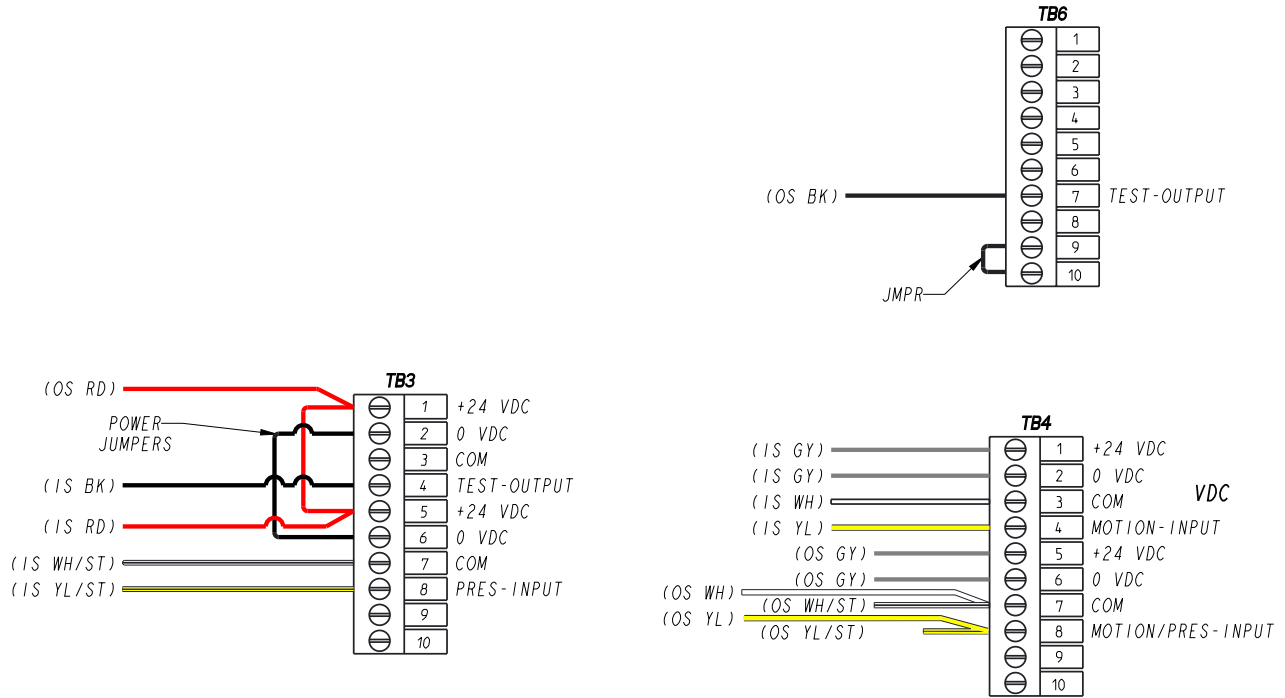

#### X-Zone ST

For Security Applications / 1-WAY

Key DIP Switch settings: 10 and 11 **DOWN**; 12, 13, 14, 15 and 16 **UP**.

#### X-Zone ST and X-Zone (ST)

Key DIP Switch settings: 10 and 11 **DOWN**; 12, 14 and 15 **UP**.

#### iQ

Remove JP301.

Set index 19 to Value = 00 (Sensor Monitoring with Threshold Control).

#### X-Zone T

Key DIP Switch settings: 11 and 12 **DOWN**; 13 and 15 **UP**.

#### iQ

Remove JP301.

Set index 19 to Value = 03 (Monitored 2 Sensors).

**NOTE::** The X-Zone ST will replace the X-Zone (ST) in 2019.

## Attachment 2 iQ System Wiring Diagram (Sheet 9 of 10)

### X ZONE T & ST 4 MONITORED SENSORS

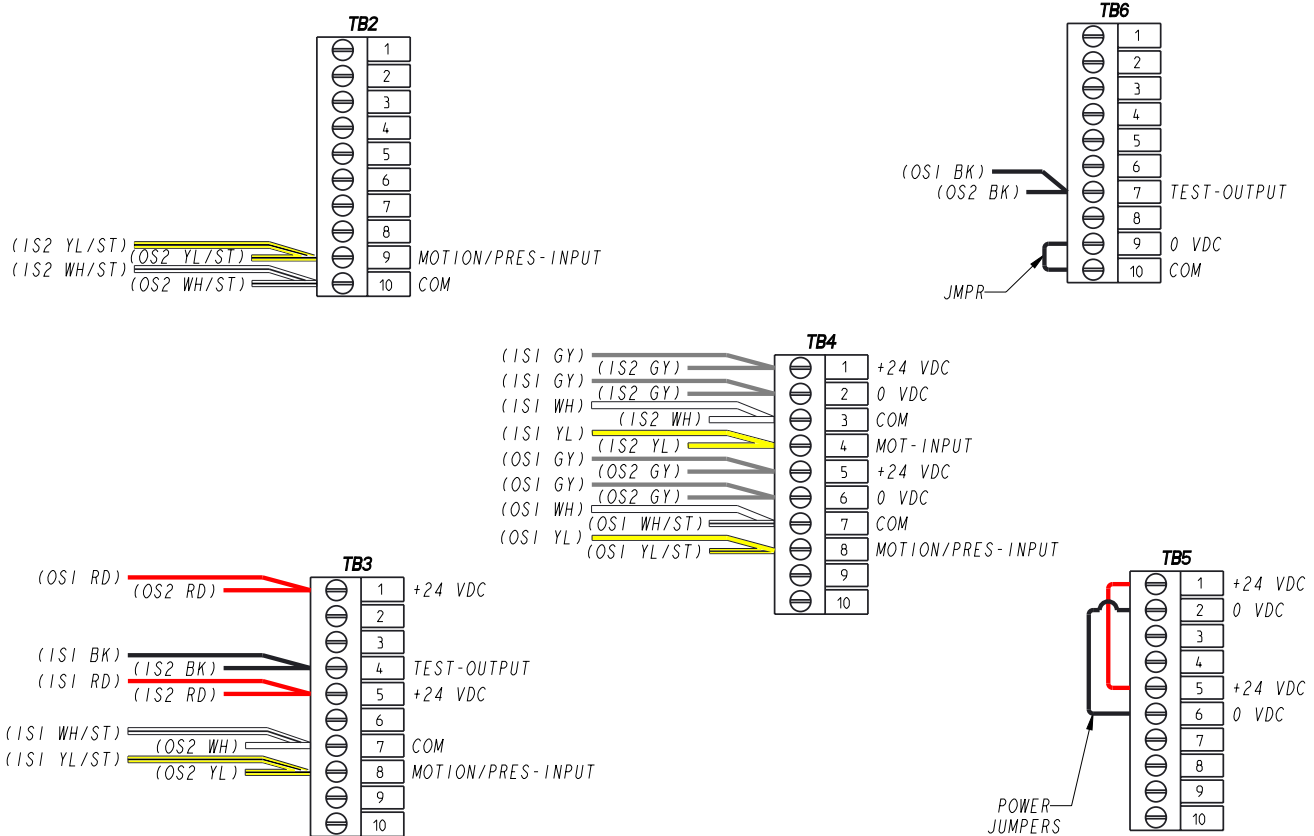

#### X-Zone ST

For Security Applications / 1-WAY

Key DIP Switch settings: 10 and 11 **DOWN**; 12, 13, 14, 15 and 16 **UP**.

#### X-Zone ST and X-Zone (ST)

Key DIP Switch settings: 10 and 11 **DOWN**; 12, 14 and 15 **UP**.

#### iQ

Remove JP301.

Set index 19 to Value = 01 (Monitored 4 Sensors - Threshold Zone Control).

#### X-Zone T

Key DIP Switch settings: 11 and 12 **DOWN**; 13 **UP** and 15 **UP**.

#### iQ

Remove JP301.

Set index 19 to Value = 05 (Monitored 4 Sensors).

**NOTE:** The X-Zone ST will replace the X-Zone (ST) in 2019.

## Attachment 2 iQ System Wiring Diagram (Sheet 10 of 10)

### HOTRON HR100-ST

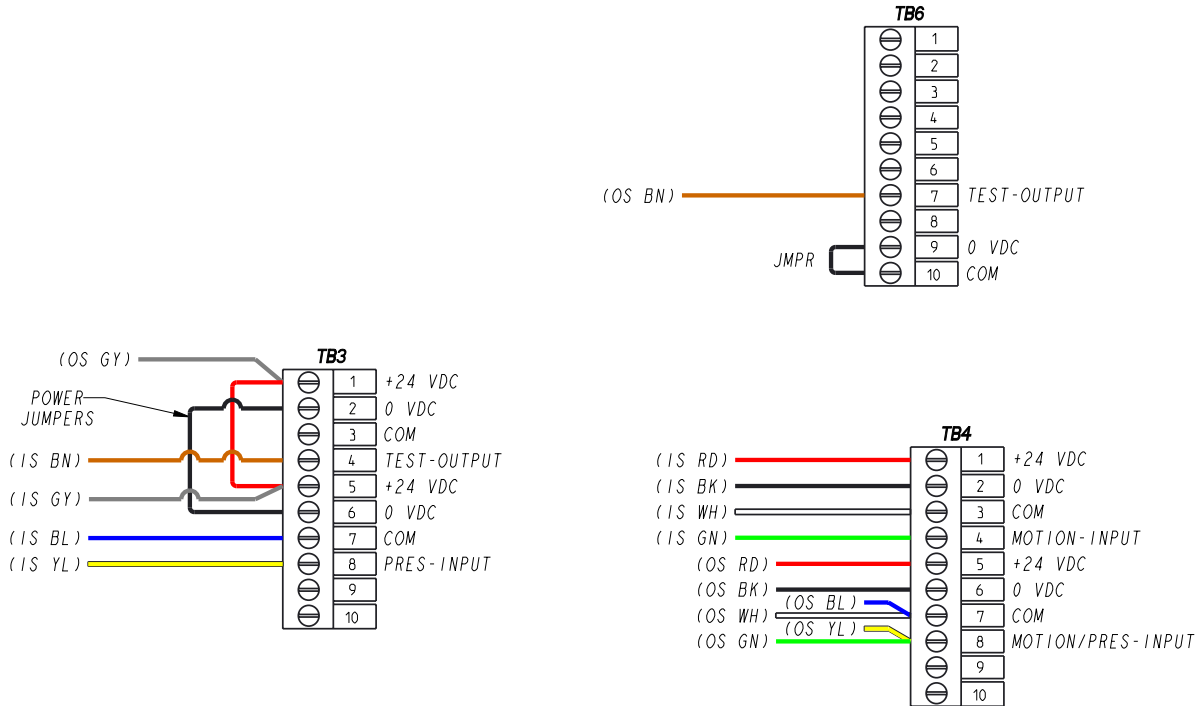

#### HR100 ST

Recommended DIP Switch settings:

DIP Switch X: (2, 3, and 4 = **UP**) (1 = **DOWN**).

DIP Switch Y: (1, 2, 3 and 4 = **UP**)

DIP Switch Z: (1, 2, 3 and 4 = **UP**) (5 and 6 = **DOWN**).

{**UP** = **OFF**} {**DOWN** = **ON**}

#### iQ Settings

Remove JP301.

Set index 19 to Value = 03 (Monitored 2 Sensors).



**CAUTION:** Tapered HR100 ST base plate must removed before sensor is installed for threshold sensor detection.

## Attachment 3 iQ Terminal Block Connections -- TB1 through TB7 (Sheet 1 of 1)

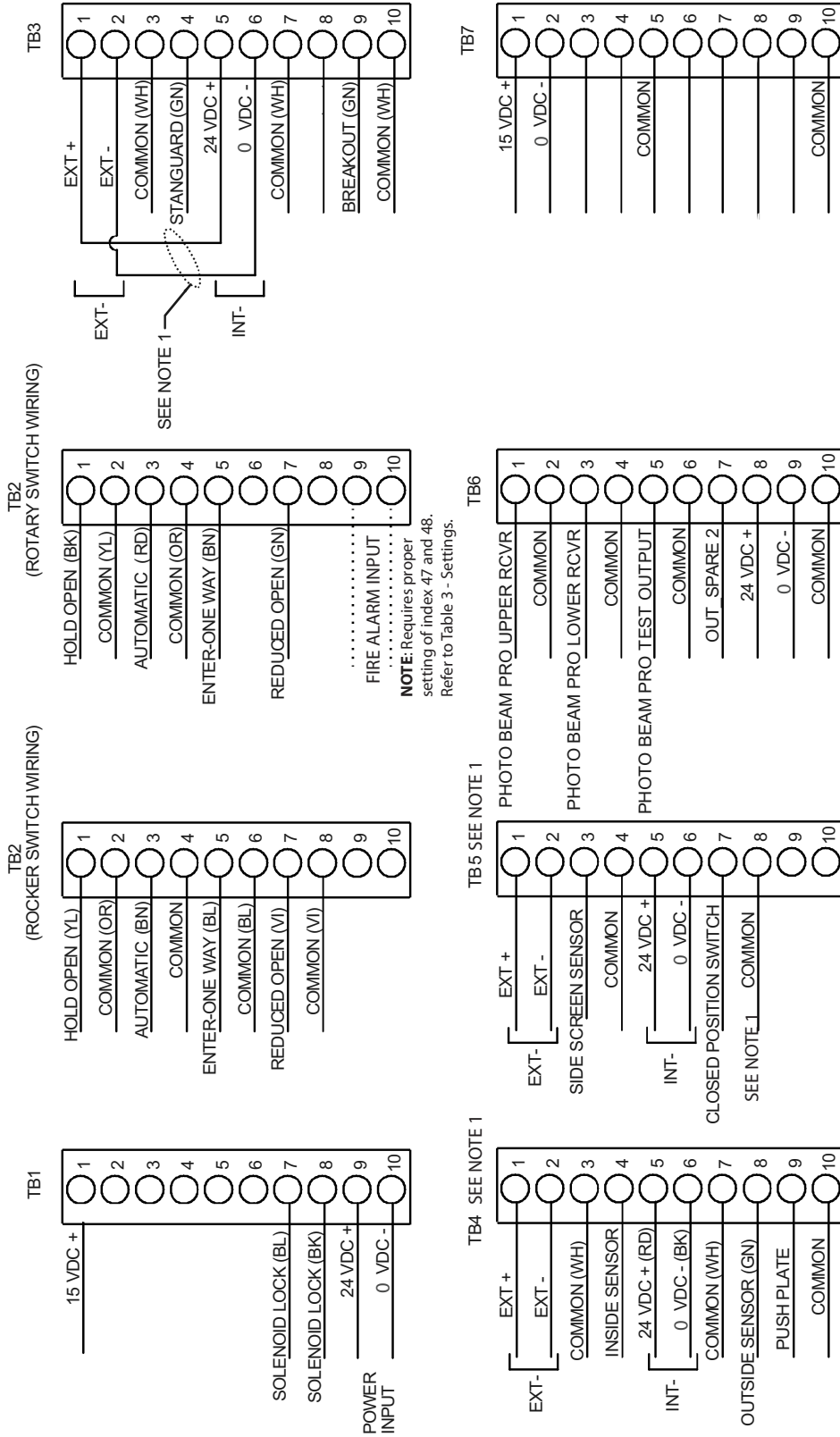

NOTE 1. REMOVE JUMPERS ON TB3 IF EXTERNAL POWER SUPPLY IS USED. JUMPERS ON TB3 CONNECT INTERNAL POWER SUPPLY (INT) TO THE EXTERNAL POWER SUPPLY BUS (EXT).

## Attachment 4 ANSI/BHMA and UL Compliance Requirements for Sliding Doors (Sheet 1 of 3)

Final adjustment and proper operation of the door system must be and shall be performed in the field.

**NOTE:** These instructions are for informational purposes and do not substitute for review against the current revision of the referenced standards. Where a requirement exists in multiple standards, such as the ANSI/BHMA standard and the UL standard, the more restrictive condition applies. Other local codes and fire codes likely exist, and must also be followed.

### ANSI/BHMA A156.10 Sliding Door Systems

---

Sliding door systems must be installed and adjusted for compliance with the current version of ANSI/BHMA A156.10, "American National Standard for Power Operated Pedestrian Doors".

Critical aspects of the installation for compliance with ANSI/BHMA A156.10 include:

- Control mat size, layout, molding height, active areas and sensitivity.
- Sensor pattern size, sensitivity, and function.
- Knowing Act guidelines and secondary activating zone.
- Entrapment protection rules including door speeds, forces, and time delays.
- Signage. (Decals and application instructions are provided with the door system.)

**NOTE:** For Procure and Duracare series Automatic series refer to the current version of ANSI/BHMA A156.38.

### UL 325 Compliance

---

All power operated door systems must be installed in compliance with the current edition of UL 325, "Standard for Safety for Door, Drapery, Gate, Louver, and Window Operators and Systems".

#### Wiring

1. To reduce the risk of electric shock proper and reliable grounding is mandatory. See **Main Power Wiring** instructions and **Wiring Diagrams** in this guide for grounding techniques.
2. Permanent wiring is to be employed as required by the National Electrical Code and/or local codes.
3. Connection of external devices is shown in the wiring diagrams and terminal block layouts elsewhere in this guide. Refer to these figures for proper wiring of external devices to ensure compliance with UL 325.

#### Knowing Act

Doors activated by a manual switch (Knowing Act switch in ANSI/BHMA terms) must have the switch installed in a location from which operation of the door can be observed by the person operating the switch and not located in a position where the user would be in the path of the moving door.



## Attachment 4 ANSI/BHMA and UL Compliance Requirements for Sliding Doors (Sheet 2 of 3)

To ensure that a sliding door operates in accordance with UL 325 entrapment protection criteria the following must be established:

- Manual opening force (sliding doors without breakout) or breakout force with power on or off must be less than 50 lbf (222.4 N).
- Closing force must be less than 30 lbf (133.4 N).
- A closing sliding door must not develop kinetic energy in excess of 2.5 ft-lbf (3.39 J). This is achieved by proper setting of the closing speed. See section entitled “Closing Speed”.
- Maximum recommended door weight:
  - Dura-Glide 5000 Series = 150 lbs (70 kg) per panel.
  - Dura-Glide/Dura-Guard/Dura-Storm and similar 2000/3000 Series = 220 lbs (100 kg) per panel.
  - IS10000/Double Diamond and similar Industrial Series = 300 lbs (90 kg) per panel

### Closing Speed

Closing speed is measured over a travel distance of 2 or 3 feet. On smaller bi-part doors there may only be 2 feet of movement before the door system enters close-check (latch check). The time measurement should start once the door has achieved closing speed, usually 6 inches from full open. Mark this point on the floor with tape or other object. Measure from this point 2 or 3 feet toward the closed position and mark the next point. Use a stopwatch to measure the time it takes for the sliding panel to travel this distance during normal closing cycles. Make sure the door system is not braking or entering close-check during the measurement. Repeat the measurement 3 times and use the average value. The allowed time for a sliding panel to cover this distance during the closing cycle is given in the table below.

Door Weight (pounds)	Closing Time (seconds) 2 foot measurement	Closing Time (seconds) 3 foot measurement
160 or less	2.0	3.0
161 to 180	2.1	3.2
181 to 200	2.2	3.3
201 to 220	2.3	3.5
221 to 240	2.4	3.7
241 to 260	2.5	3.8
261 to 280	2.6	4.0
281 to 300	2.7	4.1

**NOTE:** For low energy slide door applications refer to attachment 4 sheet 3 of 3.

**Attachment 4**  
**ANSI/BHMA and IBC Compliance Requirements for**  
**Low Energy Power Operated Sliding Doors**  
**(Sheet 3 of 3)**

To ensure that a **Low Energy** Power Operated Sliding Door operates in accordance with ANSI/BHMA and the IBC-2018, the following must be established:

- Activation of the door must be by a **Knowing Act**.
- The Opening Time (speed) of the Door(s) shall be adjusted so that the door(s) open at a speed of **12 inches per second maximum**, from fully closed to fully open.
- When powered open, the door shall remain at the fully open position for not less than 5 seconds before starting the closing cycle.
- The Closing Time (speed) of Door(s) shall be adjusted so that the door(s) close at a speed of **6 inches per second maximum** per leaf, from fully open to latch check.
- Latch check shall occur at no less than 2 inches from fully closed.
- The **force** required to prevent a stopped door from opening or closing shall not exceed 15 lbf (67 N).
- **The required Signage must be present.**

**NOTE:** In special applications where safety sensors or secondary activation sensors are used on a low energy door, refer to ANSI/BHMA A156.10 for guidance on sensor performance criteria for the type of sensor selected.

## Attachment 5 Troubleshooting Aid (Sheet 1 of 1)

Terminal and Pin	Description	State
TB1-8	Solenoid Lock Output	Dark = Unlocked
	w/o PCB, fail secure	Dark = Unlocked
	w/o PCB, fail safe	Dark = Locked

**NOTE:** Black color indicates a low signal (Approx. 0 VDC).

Rotary Function Switch States for TB2						
	Hold Open	Closed Locked	Automatic	One Way	Reduced	Reduced One Way
TB2-1						
TB2-3						
TB2-5					Don't Care	Don't Care
TB2-7						

Rocker Function Switch States for TB2						
	Hold Open	Closed Locked	Automatic	One Way	Reduced	Reduced One Way
TB2-1						
TB2-3						
TB2-5	Don't Care	Don't Care				
TB2-7	Don't Care	Don't Care				

Terminal and Pin	Description	State
TB3-4	Stanguard™ Input/Output	Dark = triggered or detecting
TB3-8 & TB4-8	Non-Monitored Holding Beam Input Input and Outside Sensor (connected internally)	Dark = detecting
TB3-9	Breakout Input	Dark = no breakout
TB4-4 & TB4-9	Inside Sensor Input and Push Plate Input (connected internally)	Dark = detecting
TB4-8 & TB3-8	Inside Presence Sensor Input and Holding Beam Input (connected internally)	Dark = detecting
TB4-9 & TB4-4	Push Plate Input and Inside Sensor Input (connected internally)	Dark = detecting
TB5-3	Side Screen Sensor Input	Dark = detecting
TB5-7	Closed-Door Position Switch Input	Dark = closed
TB5-10	Spare	
TB6-1	Monitored Beam Upper Holding Beam	Dark = unobstructed White = detecting
TB6-3	Monitored Beam Lower Holding Beam	Dark = unobstructed White = detecting
TB6-5	Photo Beam Pro Test Output	Dark = testing
TB6-7	Sensor Test Output	Dark = normal operation

Copyright 2019, Stanley Access Technologies, LLC. All rights reserved. Reproduction in whole or in part without the express written permission of Stanley is prohibited.

01.25.2019

## Attachment 6 iQ Troubleshooting Aid (Sheet 1 of 1)

Symptom	Remedy
<p>Door does not close and/or Status code displays <b>ho/E2</b></p> <p><b>NOTE:</b> E2 indicates door held open by any sensor input other than Hold Open Switch on TB-2.</p>	<p>Use best practices to troubleshoot using handheld device and provided wiring diagrams.</p> <p>Check hold beam type (index 20). Monitored beams should be set to “Monitored Beam” and non-monitored beams should be set to “Non-monitored Beam.”</p> <p>Reference latest Photo Beam Pro Troubleshooting Tech Tip.</p>
Handheld will not update firmware	Controller is not displaying 00. Re-FIS the door.
Door hits Open Stop/full open bumper	Increase the Open Check Length (Index 3).
Door motion is not the same as the MC521/ MC521PRO for the same settings	Parameters value for the iQ are not the same as MC521/ MC521PRO. Refer to Table 3.
Status code displays <b>E3</b>	<p>Check mechanical issues, components.</p> <p>Re-do first installation sequence (FIS).</p>
Status code displays <b>E4</b>	Verify sensor wiring and safety logic setting.
Status code displays <b>F0-F1, F6-F7</b>	Verify sensor wiring and safety logic setting.
Status code displays <b>F2-F3</b>	<p>Monitored beam Failure. Verify proper wiring and “holding beam type”(index 20 = appropriate setting, Monitored Beam or Non-Monitored Beam.</p> <p>Reference latest Photo Beam Pro Troubleshooting Tech Tip.</p>
<p>Door moves slowly on one cycle. Status code displays <b>33</b> or <b>34</b> or <b>36</b> momentarily (3 seconds).</p>	Note it. No action required.
<p>Door moves slowly on several cycles. Status code displays <b>33</b> or <b>34</b> or <b>36</b> on slow cycles.</p>	<ol style="list-style-type: none"> <li>1. Reset Power.</li> <li>2. If code does not clear, Call Tech Support.</li> </ol>
Door tuning issues	Refer to parameter descriptions for useful adjustments.

## Attachment 7 Fine Tuning Slide Doors (Sheet 1 of 2)

### Tuning the Stanley Automatic Door

Match your actual door to one from the list of doors described in the attachment. Start by installing these settings. Use the guide below to make adjustments to these settings.

If the door:	
<b>OPENS TOO SLOWLY</b>	Increase <b>Open Speed</b> . Maximum setting is 99 with keypad or 125 with handheld.
	If it is too slow Increase <b>Open Torque</b>
	If it is too slow Increase <b>Open Acceleration</b>
<p><b>NOTES:</b> Max Values go to 125 via handheld. Open Torque is also used to set the door open force.</p>	
<b>HITS THE OPEN STOP</b>	Increase <b>Open Stop</b> to 8 and <b>Open Check Length</b> to 45
	Increase <b>Open Brake</b> until there is good braking.
	Increase or decrease until there is good motion entering and in <b>Open Check</b> .
When the door braking and motion are under control, reduce the <b>Open Check</b> length as desired.	
<b>CLOSES TOO SLOWLY</b>	Increase <b>Close Speed</b> to 16
	If it is too slow Increase <b>Close Torque</b>
	If it is too slow Increase <b>Close Acceleration</b>
<p><b>NOTE:</b> Close Torque is also used to set the door closing force. Close Speed and Close Force cannot exceed the value specified by ANSI/BHMA 156.10.</p>	

Copyright 2019, Stanley Access Technologies, LLC. All rights reserved. Reproduction in whole or in part without the express written permission of Stanley is prohibited.

01.25.2019

**Attachment 7  
Fine Tuning Slide Doors  
(Sheet 2 of 2)**

**Tuning the Stanley Automatic Door** (Continued).

---

Match your actual door to one from the list of doors described in the attachment. Start by installing these settings. Use the guide below to make adjustments to these settings.

If the door:	
<b>HITS THE CLOSE STOP</b> too hard	Set <b>Close Check Length</b> to 50. Set <b>Close Press</b> to 1 and test. Increase the <b>Close Brake</b> setting until there is good braking. Increase or decrease <b>Close Check</b> until there is smooth motion entering and in <b>Close Check</b> .
<b>STALLS</b> during opening without any mechanical reason. . .  Continues to stall and it seems to happen at the transition from <b>Open Brake</b> to <b>Open Check</b>	Increase <b>Obstruction Time</b> from .5 seconds to 1.0 seconds
	Make small increases to <b>Open Brake</b> .
<b>STALLS</b> during closing without any obvious reason. . .  Continues to stall and it seems to happen at the transition to Close Check	Increase <b>Obstruction Time</b>
	Increase <b>Close Check</b> one count at a time
<b>SPEEDS UP</b> during Close Check	<b>Close Check Speed</b> is set too high. Reduce <b>Close Check</b> one count at a time until door motion is suitable.