

STANLEY[®]

**MAGIC-SWING
HEAVY WEIGHT DOOR PACKAGE**

Spring Open, Power Close

Installation Instructions

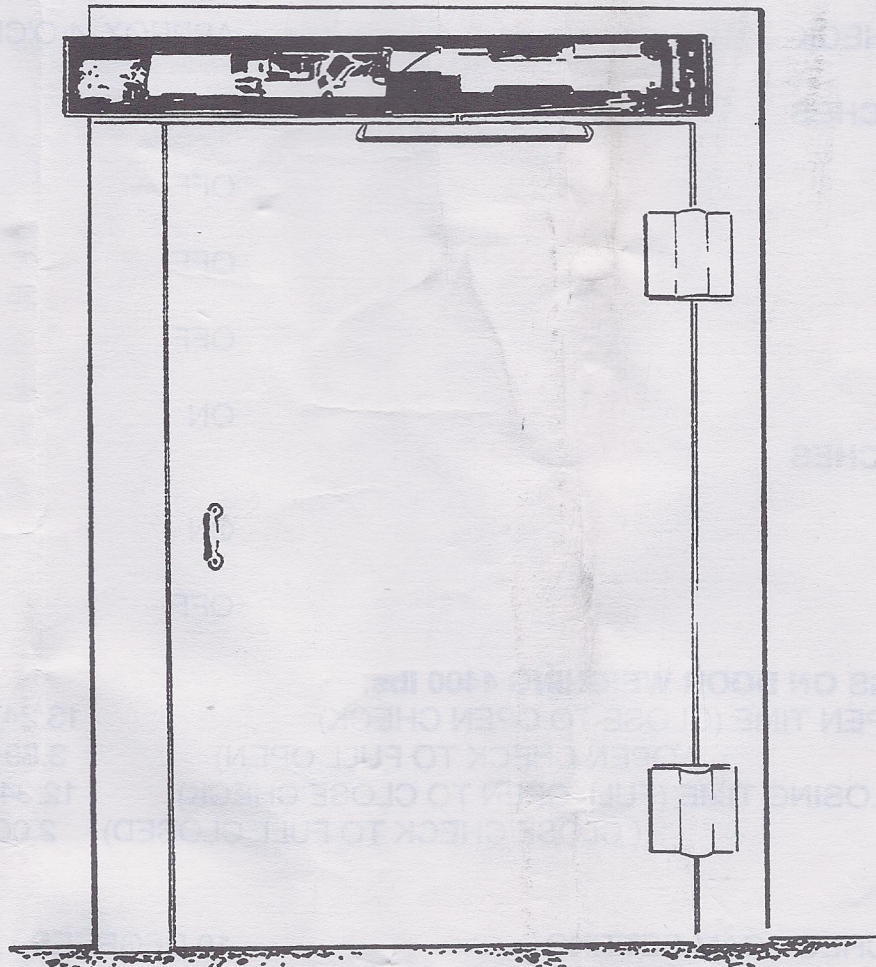

DOOR WEIGHT RANGE 4200 lbs to 5000 lbs.

CONTROL NAME	ADJUSTMENT SETTING
POWER CLOSE MODULE - (JUMPER INSTALLED)	TIME - MIN
	LOAD - MID RANGE
CLOSING SPEED ADJUSTMENT	MIN
HOLD OPEN DELAY	ADJUSTMENT NOT USED
STALL	MAX
OPEN SPEED	APPROX. 8 O'CLOCK
OPEN CHECK	APPROX. 4 O'CLOCK

S2 SWITCHES

#1	OFF
#2	OFF
#3	OFF
#4	ON

S3 SWITCHES

#1	ON
#2	OFF

SETTINGS ON DOOR WEIGHING 4400 lbs.

OPEN TIME (CLOSE TO OPEN CHECK)	13.24 SEC.
(OPEN CHECK TO FULL OPEN)	3.39 SEC.
CLOSING TIME (FULL OPEN TO CLOSE CHECK)	12.34 SEC.
(CLOSE CHECK TO FULL CLOSED)	2.00 SEC.

CLOSE CHECK CAM SETTING	10 DEGREES
OPEN CHECK LIMIT SWITCH (DISABLE POWER CLOSE MODULE)	20 DEGREES

Functional Description

The Magic-Swing HD, Spring Open, Power Close Operator utilizes the Magic-Swing Microprocessor Control Box (P/N 110277) with a special version of software for reversing the Obstruction and Open/Close Logic for the reversed door motion. The revised software is P/N 713343.

The Operator used in the application is the opposite hand of the door opening and is configured such that when power is removed from the operator, the spring is released and the door swings open.

The Operator and Control System are designed to function in the 2S (Push-to-Open, Push-to-Close) mode for a single door application and NO BREAKOUT.

The System is intended to function with 2 separate Push Button Inputs, designated "Full Open" and "Part or Half Open". Activation of the Push Button designated "Full Open" commands the door to cycle to the Full Open (90°) position. Activation of the Push Button designated "Half-Open" commands the door to cycle to a reduced opening of approximately 45° or 1/2 the spindle rotation of the operator. Either Push Button Input can command the door to close from either Full Open or Part Open.

The opening direction speed is controlled by the Braking Resistor on the Operator, or a Closing Speed Control (P/N 516214), if desired. If a Power Close Module is used for power assisting the door in the opening direction, the "Level" setting of the Power Close Module will determine the Opening Speed.

The opening direction Check position is controlled by the switch plate and Cam on the operator. This is adjustable by rotation of the Cam. The opening direction Check Speed is not adjustable.

The closing direction speed is controlled by the Open Speed potentiometer on the Magic-Swing Control Box. Likewise, the closing direction Check Speed is controlled by the Open Check Speed Potentiometer on the Magic-Swing Control Box.

The software is designed to brake the door in both directions near the Full Open and Full Closed positions. In the Closing direction, the braking is applied at the point of the closing direction Check. In the Opening direction, the braking is applied at a selectable angle of 5° or 10°. The braking allows the control to reduce the effects of the momentum of the door.

When used with Power Close, the system can be set up to power-assist in the opening direction. The cancel feature for the Power-Close Module can be wired through the Open Check Cam on the Switch Plate in the Operator as this is not used by the Magic-Swing Microprocessor Control Box. This allows the door to be power-assisted to get moving in the Open direction, and then once moving, the Power-Close Module can be shut off which then allows the Operator's spring and Closing Speed Control to finish opening the door.

Power Close can also be set to assist in moving the door for the entire opening travel (90°), with a canceling of Power Close once the door is at full open, again through use of the Open Check Cam.

NOTE: If Power Close is used for the entire opening cycle, the opening speed adjustment is the setting of the "Level" adjustment on the Power-Close Module, and the Closing Speed Control and Operator Braking Resistor are ineffective. (No Open Check will be apparent.)

General Information

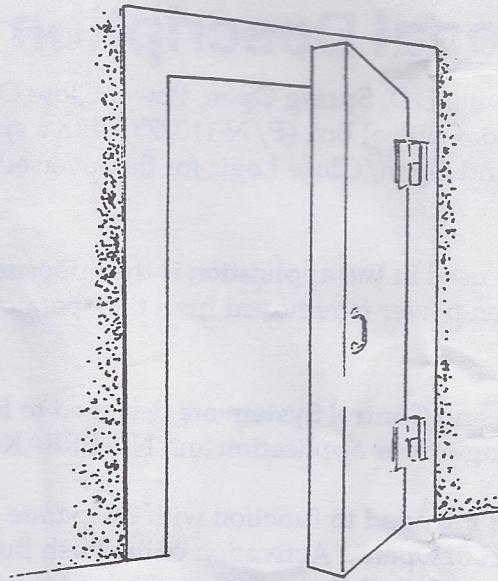

Doors must swing freely on hinges or pivots of adequate size for good automatic door operation. The doors, even though not supplied by Stanley, must be checked for the following items as they influence the operation of the automatic door equipment:

1. Check door and frame for proper installation and clearance - $1/8"$ at top and lead edge, $3/16"$ at floor.
2. If hinged, make sure the hinges are firmly secured to the door and frame.

Header Preparation

Prepare Header for adequate support of operator in accordance with dimensions shown on Header Detail, strong enough to hold operator in use.

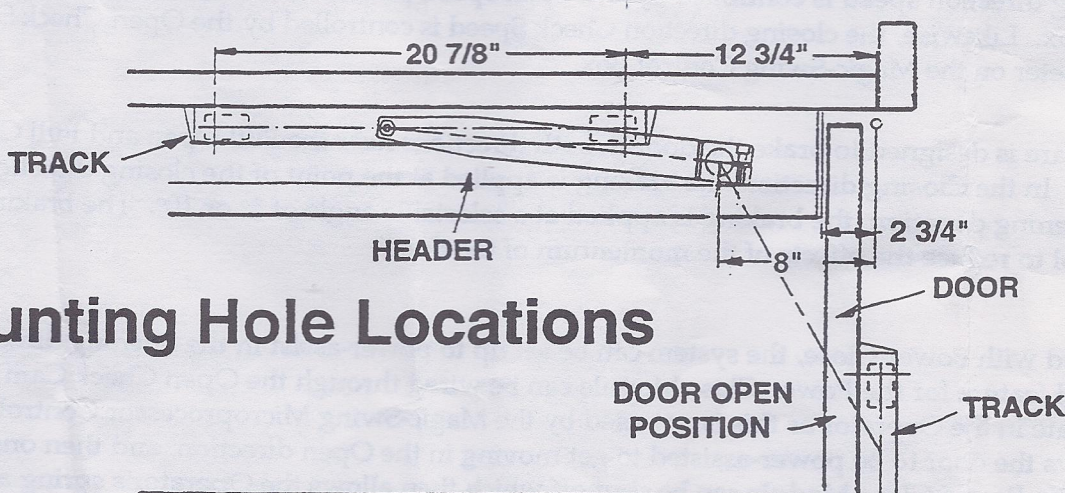

Mounting Hole Locations

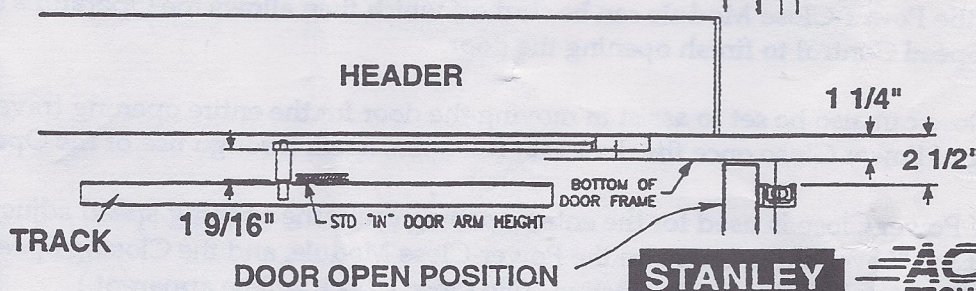

STANLEY

ACCESS
TECHNOLOGIES

NOTE:

Any reference to printed material on product labels for "OPEN" or "CLOSE" must be reversed. For example, the Open Speed Potentiometer adjusts the Closing Speed, while the Close Check Cam in the Operator adjusts the Open Check angle.

The Closing Speed Control adjusts the Opening Speed (except during Power Assist), when the Power Close Module sets the Opening Speed.

IMPORTANT!!

LABEL APPLICATION: The Caution label must be installed on the back of the header or the inside surface of the end cap. This is primarily for the reference of equipment function for whomever may follow you for service.

Microprocessor Installation:

CAUTION!!

- The Magic-Swing Microprocessor Control Box must be disconnected from power.
- The microprocessor box must be placed on a properly grounded anti-static work mat.
- The service technician should be wearing an anti-static wrist strap which is also properly grounded.

You must install a special version of software in the microprocessor control box for this type of application. The operation as explained is spring open, power close. See location of microprocessor in Control Box Instruction Manual #203821, figure 1.

- a) Remove the microcontrol box cover.
- b) Remove the existing microprocessor (identified by P/N 712648).
Insert a small, slotted screwdriver under the microprocessor and carefully pry the I.C. out of the socket. Once the I.C. has been lifted, remove the I.C. and discard.
- c) Install the new microprocessor (identified by P/N 713343).
 1. Carefully remove the I.C. from the anti-static box.
 2. Install the new I.C. in the socket.

IMPORTANT!!

The I.C. must be placed in the socket with care and must be positioned in the proper direction (see illustration).

NOTE:

The notch or polarity indicator on one end of the I.C. must face the speed potentiometers. Carefully align the I.C. pins with the holes in the socket. Press the I.C. carefully, but firmly, into the I.C. socket.

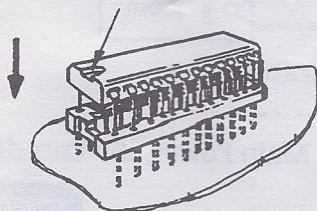

Wiring

There are two connectors used for electrical input/output to the control box. (See Figure 1 in Magic-Swing Microprocessor Control Box Instruction Manual #203821). See wiring diagrams for individual applications.

A. TB1

TB1 is used to connect the signal inputs as listed:

TB1 Position	Connection
1	Signal Common
2	Full Open Press Plate Input
3	Not Used
4	12 VAC (rated at 1 AMP max.)
5	12 VAC
6	Auxiliary Input (Part Open Press Plate Input)
7	Not Used
8	Common

Note: *The control box is shipped with a jumper across TB1 pins 6 to 8. This jumper must be removed for this application.

MAGIC-SWING RADIATION DOOR ELECTRICAL INTERCONNECTIONS

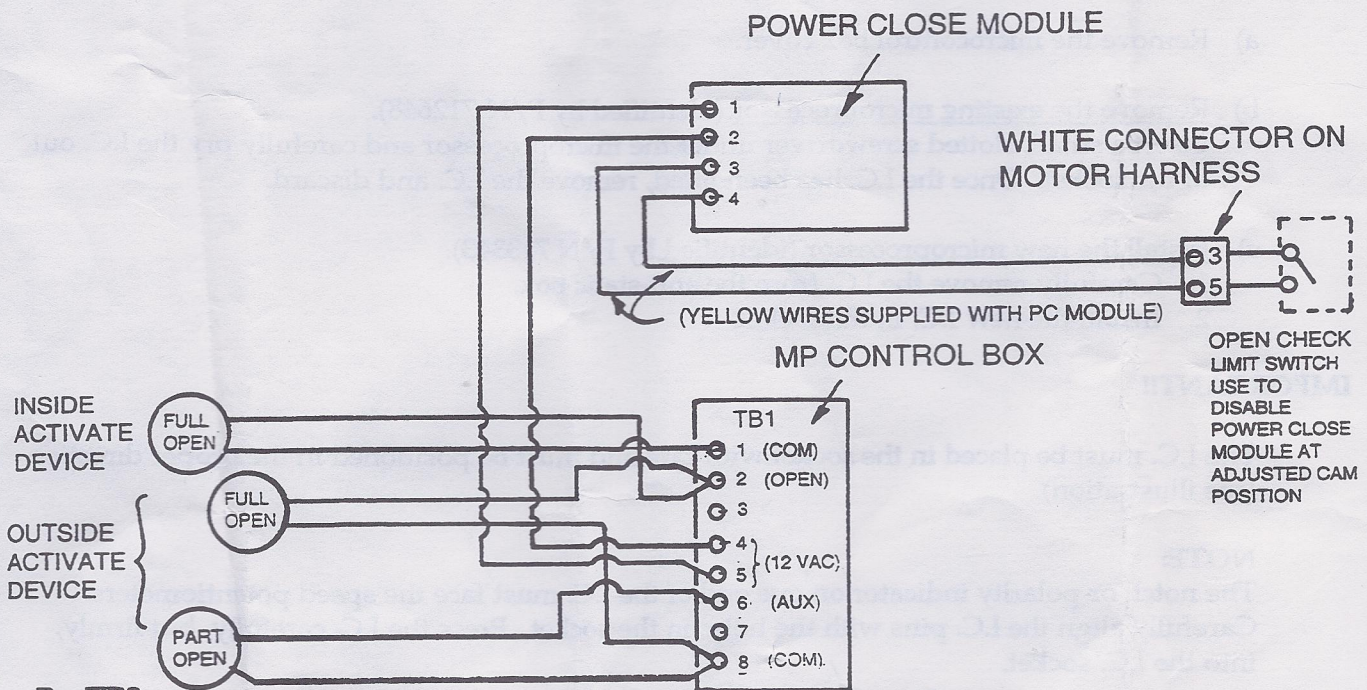

B. TB2

Sentrex Connector - not used for this application.

C. J1

J1 accepts the harness which connects the Main Power, the Encoder and the Motor directly to the Magic-Swing Control Box.

D. MAIN POWER

CAUTION: TURN SERVICE PANEL POWER OFF BEFORE CONNECTING HARNESS J1 TO ELECTRICAL SERVICE.

(Refer to pages 8 and 9 of the Magic-Swing Microprocessor Control Box Instruction Manual for system schematic.)

1. Connect the Ground Wire Assembly (P/N 711527) to the Electrical Service Ground Wire using a wire nut (provided).
2. Drill a hole for a #8 screw on the inside of the Header, preferably in a concealed location.
3. Place the ring terminal from the ground wire on to the #8 screw provided and screw into Header.
4. Drill a second hole for a #8 screw on the inside of the Header (concealed location).
5. Place the ring terminal from the Main Harness - J1 on to a #8 screw (provided) and screw into Header.
6. Connect the Power Pigtail Assembly (P/N 712846) to the Electrical Service, connecting line (black) to black and neutral (white) to white using wire nuts provided.
7. Plug the Power Pigtail into the Main Harness J1 power connection.

E. POWER CLOSE (if required)

The Power Close Module (P/N 313367) is used to power assist opening door motion. Follow the instructions in the Power Close Module Installation and Tune-In Manual #203863. Note that the Open Check Limit Switch is used to cancel the Power Close Signal once the door starts moving.

Essentially, Power Close is used just to get the door in motion, i.e. the first 20°. Once in motion, Power Close is cancelled through the use of the Open Check Limit Switch.

F. OPENING SPEED CONTROL (if required)

The Closing Speed Control (P/N 516214) is utilized when the opening speed for the Magic-Swing Radiation Door Operator must be reduced. Follow the instructions on the Closing Speed Control for connecting to the system.

G. ACTIVATING DEVICES

The system is designed to function with activating devices, i.e. Press Plates, on both sides of the door.

One Press Plate, designated Full Open, is connected across TB1 terminals 1 and 2. There is (1) Full Open Press Plate on each side of the door.

The second Press Plate, designated Part Open, is connected across TB1 terminals 6 and 8. There is (1) Part Open Press Plate in the system, typically located outside of the X-Ray room.

The activating devices function as follows:

1. When a Full Open Signal is applied to a closed door, the Control Box will swing the door to the Full Open (90°) position.
2. When a Part Open Signal is applied to a closed door, the Control Box will swing the door to the Half Open (45°) position.
3. When either a Full Open or Part Open Signal is applied to an Open Door (Full or Part Open), the Control Box will swing the door fully closed (0°) position.

H. Selectable features through the DIP switches include:

S2:

- 1 Brake Angle, 5 or 10° in opening direction
 - 2 Single / Dual, LEAVE OFF (for Single)
- Brake Delay Time (either direction)

S2-3 S2-4

off	off	0.25 seconds
on	off	0.5 seconds
off	on	1.0 second
on	on	1.5 seconds

S3:

- 1 Open Check Size Select: ON = small check, OFF = large check
- 2 Learn Speed Select: ON = first cycle, door opens in Learn Speed
OFF = first cycle, door opens in Check Speed

NOTE:

Any reference to printed material for "OPEN" or "CLOSE" must be reversed. For example, the Open Speed Potentiometer adjusts the Closing Speed, while the Close Check Cam in the Operator adjusts the Open Check angle.

The Closing Speed Control adjusts the Opening Speed (except during Power Assist), when the Power Close Module sets the Opening Speed.

I. **INITIAL RUN SETTINGS**

The following page defines the adjustments for a typical installation with a door weighing 4400 lbs. These adjustments are given to help the installer initially tune in this door system. Once installed and running, minor adjustments may be required to make the system run more appropriately for the installed conditions.