

Stanley Access Technologies
Quick-Reference Guide



**Magic Swing™ HDLE/FE Microprocessor
Control Box Quick-Reference Guide**

203959, Rev. A

9/3/99

Quick-Reference Guide

TABLE OF CONTENTS

1. PURPOSE 1

1.1 Discussion..... 1

1.2 Applicability 1

1.3 Features and Functions 2

2. WIRING INSTRUCTIONS 3

2.1 Evaluating Power Requirements..... 3

2.2 Connecting Main Power Wiring 3

2.3 Connecting Breakout Status Signal Wiring (Magic-Swing™ Operators) 4

2.4 Wiring the ON/OFF/HOLD OPEN Switch 5

2.5 Wiring the Door Activation or Safety Device 6

2.6 Wiring Sentrex³ 6

2.7 Wiring the Counter 6

3. TUNE-IN INSTRUCTIONS..... 6

3.1 Initial Tune-In Settings 6

3.2 Final Tune-In Adjustments 7

Attachments

Attachment 1, Magic-Swing System Wiring—Main Power, Motor(s), and Encoder(s)..... 8

Attachment 2, Breakout Status Wiring 9

Attachment 3, Signal Wiring—Magic-Swing Control Box with Carpets, Pushplate, Operate Sensor,
or Safety Sensor 10

Attachment 4, Wiring Diagram—Magic-Swing Control Box with Sentrex³ 11

Attachment 5, Wiring Diagram—Magic-Swing Control Box with Bifold Doors..... 12

Attachment 6, DIP Switch S2 Mode Settings..... 13

Attachment 7, Magic-Swing HDLE/FE Microprocessor Control Box..... 15

1. PURPOSE

1.1 **Discussion**

This manual provides abbreviated descriptive information, wiring instructions, and tune-in instructions for the microprocessor control box. The manual is intended as a quick-reference guide. For more complete information regarding the general description, principles of operation, installation, wiring, tune-in, and troubleshooting of this component refer to Document No. 203958, "Magic-Swing™ HDLE/FE Microprocessor Control Box Operation."

1.2 **Applicability**

Two configurations of the microprocessor control box are currently in use; each with a distinct decal on the control box cover. The newer (HDLE/FE) configuration is identified by a decal with yellow text on a black background. The common name for this configuration is the black-label box. The early model configuration is identified by a decal with black text on a yellow background. The common name for this configuration is the yellow-label box. Black-label control boxes can replace yellow-label boxes, but yellow-label boxes *cannot* replace black-label boxes. *This manual covers operation of HDLE/FE (black-label) control boxes only.* For yellow-

label control box operating instructions, refer to Stanley Access Technologies document No. 203821, "Magic-Swing™ Microprocessor Control Box."

Attachment 6 provides an overview of the HDLE/FE control box. Additional differences between the yellow-label and black-label boxes include the following:

- The power switch has been deleted.
- A torque potentiometer has been added to accommodate adjusting from low to full energy.
- A separate 5-to-20-second Magic-Touch™ time delay has been added.
- A Magic-Touch™ sensitivity adjustment has been added.
- Control box dual in-line package (DIP) switch configurations have changed. On yellow-label control boxes, DIP switch S2 is a four-bank switch and DIP switch S3 is a two-bank switch. On black-label control boxes, DIP switch S3 has been eliminated and DIP switch S2 has been replaced with a larger seven-bank switch. The larger switch controls the features previously controlled by S3. On black-label control boxes, rotary switch S4 has been added to control the Magic-Touch™ time delay.
- A counter activation signal has been provided.

1.3 Features and Functions

- 1.3.1 Magic-Touch™: A feature that allows the door to be actuated by a slight manual movement of the door--without the need for an approach sensor. Magic-Touch™ can be used with press plates or a radio control system, providing the system two time delays. Magic-Touch™ is not recommended for use with a dual door system using Sentrex.
- 1.3.2 Learn Speed: When power is first turned on and an "open" signal is applied, the control box opens the door in "learn speed," a slightly faster speed than open check. The controller counts encoder pulses, learning the operator rotation from closed to open. The calculated learn value is lost whenever power is lost.
- 1.3.3 Reverse-On Obstruction: A one-second reverse-on obstruction feature causes the door to reverse motion if an obstruction is met during door opening or closing.
- 1.3.4 Safety Check: This feature monitors the safety signal activation on every open cycle. If a safety carpet or overhead safety sensor fails "open" and can no longer detect a pedestrian, the door stays open for 12 seconds to indicate that there is a problem.
- 1.3.5 Emergency Breakout: Disconnects power to the motor when door is manually pushed in the emergency-out direction. The operator then automatically resets and power is resumed.
- 1.3.6 2S Logic: Used in trained-traffic applications and is not compatible with sensors. Allows door to open when switch is pushed and door to close when next sequential switch is pushed.
- 1.3.7 Automatic Open Check Calculation: Open check position—the area where the door slows down before fully open—is calculated for approximately 80° in the opening direction during "learn cycle."

- 1.3.8 Bifold Safety Sensor Logic: Allows manual selection of bifold logic versus carpet or timer logic via DIP switch. Used in bifold door systems, it eliminates the need for a lock-out relay for the overhead safety sensor.
- 1.3.9 Single or Dual Door Selection: Allows manual selection of single or dual door operation via DIP switch.
- 1.3.10 Opening Speed Adjustment: Opening speed potentiometer permits adjustment of door opening speed.
- 1.3.11 Open Check Speed Adjustment: Open check speed potentiometer permits adjustment of door open check speed.
- 1.3.12 Torque Adjustment: Allows adjustment of the door opening force.
- 1.3.13 Stall Logic: Used with a door-mounted sensor system to stop door motion when a pedestrian or object is present.

2. WIRING INSTRUCTIONS

2.1 **Evaluating Power Requirements**

2.1.1 EVALUATE door system power requirements as follows:

- ENSURE power source is a dedicated 117 VAC, 50/60 Hz source with 20A circuit rating per two-door system.
- ENSURE power source is not shared with other equipment, i.e., cash registers, EAS systems, or other electromagnetic interference generators.

2.2 **Connecting Main Power Wiring**

WARNING

To prevent injury to personnel, incoming electrical power to header must be deenergized before connecting control box electrical harness to electrical service.

- 2.2.1 DEENERGIZE incoming electrical power to header.
- 2.2.2 Refer To Attachment 1, and, using the wire nut provided, CONNECT ground wire assembly (P/N 711527) to electrical service ground wire.
- 2.2.3 In a concealed location inside the header, DRILL a hole for a No. 8 screw.
- 2.2.4 INSTALL ground wire ring terminal onto the No. 8 screw provided, and FASTEN screw and ground wire to header.
- 2.2.5 In a concealed location inside the header, DRILL a second hole for a No. 8 screw.
- 2.2.6 INSTALL main harness (J1) ring terminal onto the No. 8 screw provided, and FASTEN screw and ground wire to header.
- 2.2.7 Using the wire nuts provided, CONNECT power pigtail assembly (712846) to electrical service as follows:
 - CONNECT power pigtail assembly black wire to black (line) service wire.
 - CONNECT power pigtail assembly white wire to white (neutral) service wire.
- 2.2.8 ENSURE power pigtail assembly is *not* connected to main harness connector J1.

2.3 Connecting Breakout Status Signal Wiring (Magic-Swing™ Operators)

WARNING

To prevent injury to personnel and damage to equipment, control box power must be deenergized before connecting breakout status signal wiring.

CAUTION

If the motor is running and the breakout status switch is *not* connected, arcing across the breakout switch contacts can occur. This will result in damage to the breakout switch. To prevent damage from switch contact arcing, the breakout status switch must *always* be connected.

2.3.1 ENSURE power pigtail assembly is disconnected.

NOTE

1. The breakout status switch should be used in *all* applications where there is no positive door stop in the breakout direction.
2. The auxiliary switch is the breakout status signal switch. The auxiliary switch was formerly the open check switch on the operator switch plate (top cam).

2.3.2 Refer To Attachment 2 and CONNECT breakout status wiring.

2.3.3 REMOVE quick-connect terminal (brown wire) from the normally open terminal of the auxiliary switch (formerly open check switch), and INSTALL onto normally closed terminal.

2.3.4 CONNECT yellow jumper wires installed on the single/dual motor harness as follows:

- REMOVE control box jumper wire from terminals 6 and 8.
- INSTALL stripped end of first jumper wire (from position 3 of 8-pin connector on operator harness) into terminal 6 of control box connector TB1.
- INSTALL stripped end of second jumper wire (from position 5 of 8-pin connector on operator harness) into terminal 8 of control box connector TB1.

2.3.5 SET the auxiliary cam for approximately 3° activation (toward breakout direction), and ADJUST cam as necessary to trip the corresponding microswitch prior to activation of the breakout switch.

NOTE

In a dual-door application, the breakout switches of each operator need to be wired in series to ensure that the control box will not open the doors if either breakout status switch is activated.

2.3.6 IF application is a pair of doors, PERFORM the following:

- a. REPEAT steps 2.2.3 and 2.2.4 for the second door operator.
- b. CONNECT stripped end of one yellow jumper wire from each operator across terminals 6 and 8 of control box connector TB1.

2.3.7 Using a wire nut, CONNECT remaining wire from first operator to remaining wire on second operator.

2.3.8 VERIFY breakout status/breakout cam is properly set as follows:

203959, Rev. A

9/3/99

4 of 15

- a. Refer To Figure 1, and visually INSPECT cams for proper setting.

Figure 1. Breakout Status/Breakout Cam Settings (Magic-Swing Operators)

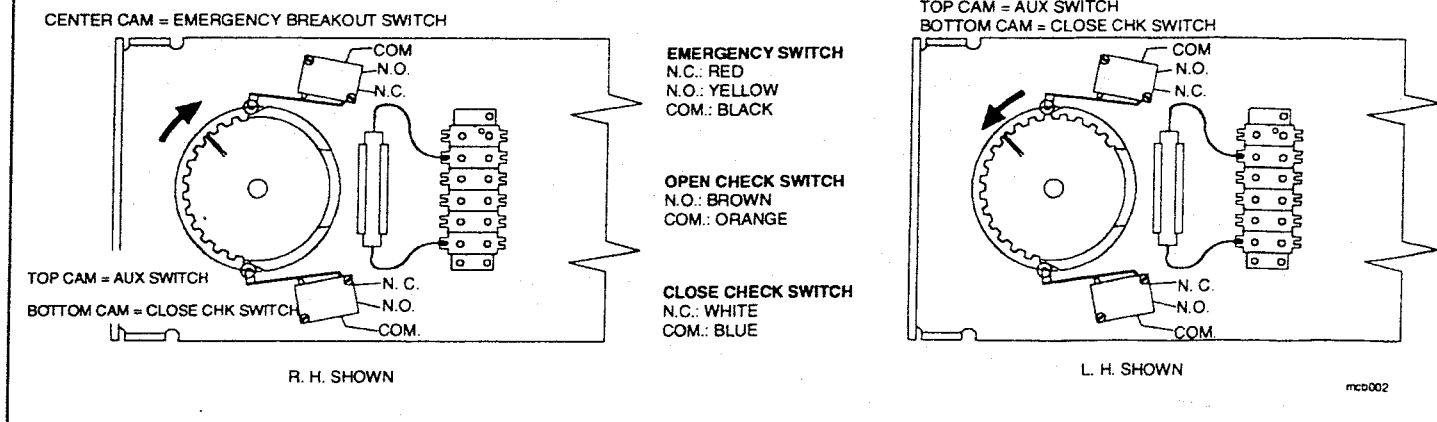

- b. UNPLUG TB1 from control box circuit board.

NOTE

When checking breakout status switch continuity, the switch is first checked with the door closed, then again with the door in the breakout (negative 3°) position. In a dual-door application, both doors can be tested at the same time in the closed position. However, the doors must be tested *individually* when checking switch continuity with the doors in the breakout (negative 3°) position.

- c. ENSURE door is in the closed position.
- d. Using a multimeter, CHECK continuity between TB1 terminals 6 and 8, and ENSURE there is continuity.
- e. PUSH door in the breakout direction, and HOLD door at approximately the negative 3° position.
- f. Using a multimeter, CHECK continuity between TB1 terminals 6 and 8, and ENSURE there is an open circuit.
- g. RELEASE door.
- h. PLUG TB1 into control box circuit board.

2.4 Wiring the ON/OFF/HOLD OPEN Switch

- 2.4.1 Refer To Attachment 3, and CONNECT ON/OFF/HOLD OPEN switch wiring as follows:

TB1 Terminal	Connection	Hold Open Switch Wire Color
1	Common	Yellow
2	Operate	Orange
3	Sensors	Violet

2.5 Wiring the Door Activation or Safety Device

NOTE

Attachment 4 illustrates typical wiring for various devices. Though the specific device may not be shown, this attachment can be used as a general guide. Specific wiring instructions from the manufacturer must also be consulted.

2.5.1 Refer To Attachment 4 and applicable manufacturer's instructions, and CONNECT door activation or safety device.

2.6 Wiring Sentrex³

2.6.1 Refer To Attachment 5 and CONNECT Sentrex³ as follows:

TB2 Terminal	Connection	Sentrex ³ Wire Color
1	VSX (+) Power for Sensor Head	Red
2	Serial Communication	Green
3	Serial Communication	White
4	GND (-) Ground for Sensor Head	Black

2.7 Wiring the Counter

2.7.1 Refer To Figure 2, and CONNECT wiring for counter.

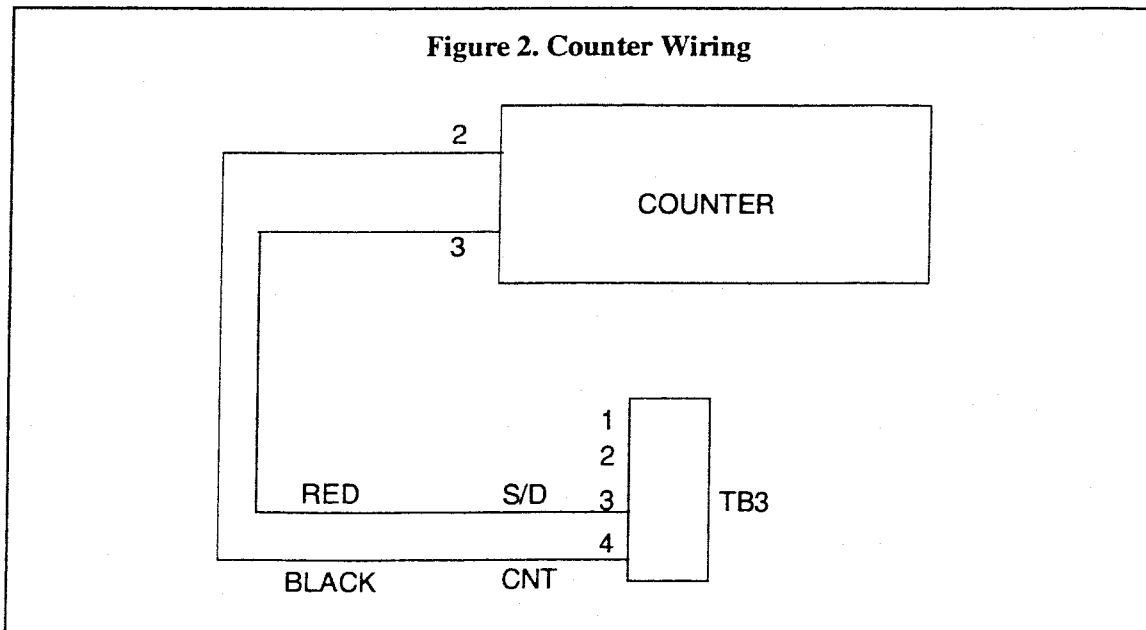

3. TUNE-IN INSTRUCTIONS

3.1 Initial Tune-In Settings

3.1.1 DISCONNECT power pigtail assembly.

WARNING

To prevent injury to personnel and damage to equipment, the following settings must be made *before* applying power to control box.

- 3.1.2 SET potentiometers and switches to initial positions as follows:
- SET stall speed potentiometer to full clockwise (maximum) position.
 - SET torque potentiometer to full clockwise (maximum) position.

CAUTION

To ensure proper operation of door, DIP switch S1 must be set to "H" (high range) on *all* Magic-Swing™ and bifold applications.

- For all Magic-Swing™ and bifold applications, SET DIP switch S1 to "H" (high range).
- SET open speed potentiometer to midrange position.
- SET open check speed potentiometer to $\frac{3}{4}$ of full clockwise position.
- SET time delay potentiometer to full counterclockwise (minimum) position.
- SET Magic-Touch™ time delay rotary switch S4 to 0.

- 3.1.3 Refer To Attachment 5, and PERFORM tune-in as applicable.

3.2 Final Tune-In Adjustments

- 3.2.1 ENSURE door opening path is clear of all wires and obstructions.
- 3.2.2 SET ON/OFF/HOLD OPEN switch to OFF.
- 3.2.3 CONNECT power pigtail assembly.
- 3.2.4 Refer To ANSI A156.10, "American National Standard for Power Operated Doors," and DETERMINE ANSI door operating requirements.
- 3.2.5 CYCLE and RECYCLE door several times to verify proper speeds and forces, and PERFORM adjustments in the following order:
 - Open speed potentiometer
 - Open check speed potentiometer

CAUTION

To prevent motor overheating and premature motor failure, stall speed potentiometer must *not* be set too high.

- Stall speed potentiometer
- Torque potentiometer
- Time delay potentiometer
- Magic-Touch™ time delay rotary switch

Attachment 1

Magic-Swing System Wiring—Main Power, Motor(s), and Encoder(s)

(Sheet 1 of 1)

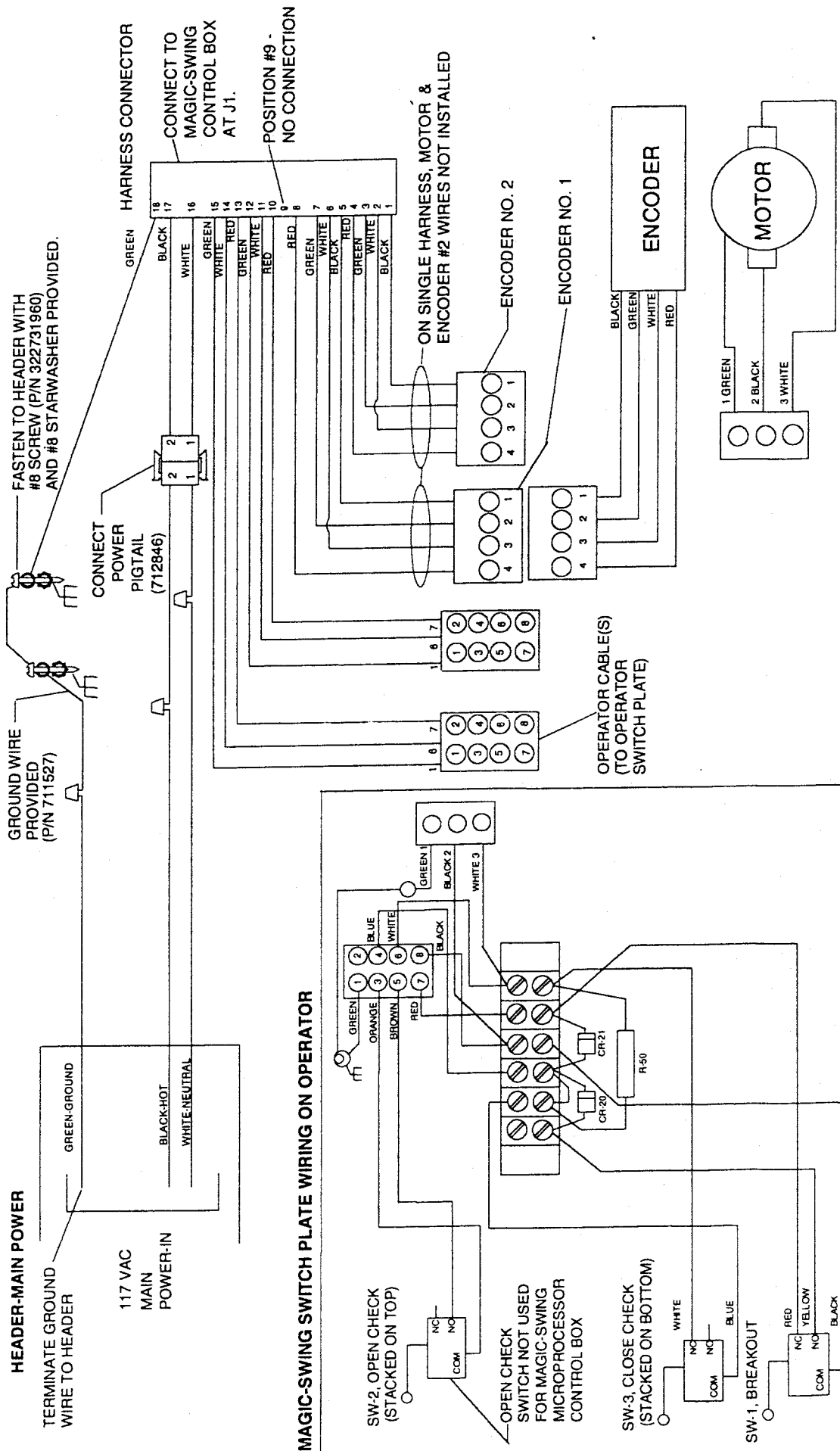

11040127

Attachment 2 Breakout Status Wiring (Sheet 1 of 1)

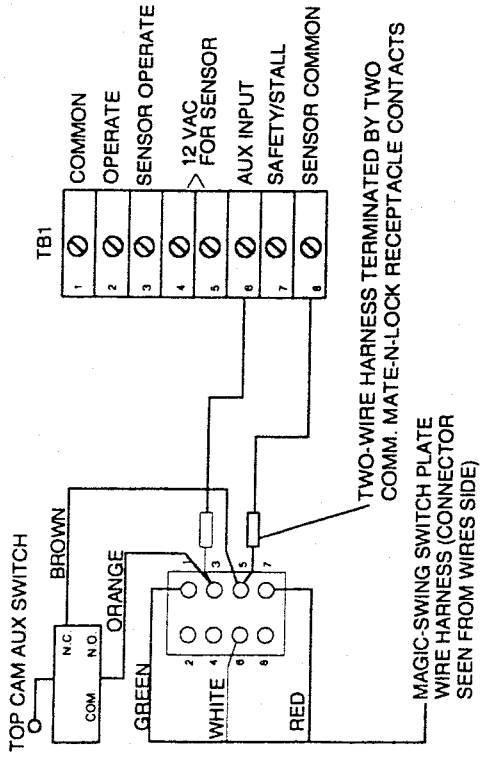

BREAKOUT STATUS WIRING—SINGLE DOOR

NOTE: REMOVE CONTROL BOX JUMPER WIRE FROM TERMINALS 6 AND 8.

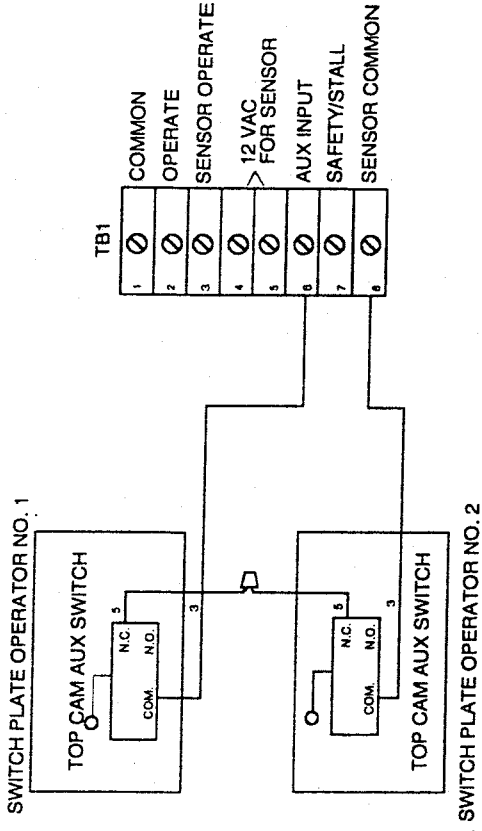

BREAKOUT STATUS WIRING—DUAL DOOR

mcbao017

Attachment 3 Signal Wiring--Magic-Swing Control Box With Carpets, Pushplate, Operate Sensor, or Safety Sensor (Sheet 1 of 1)

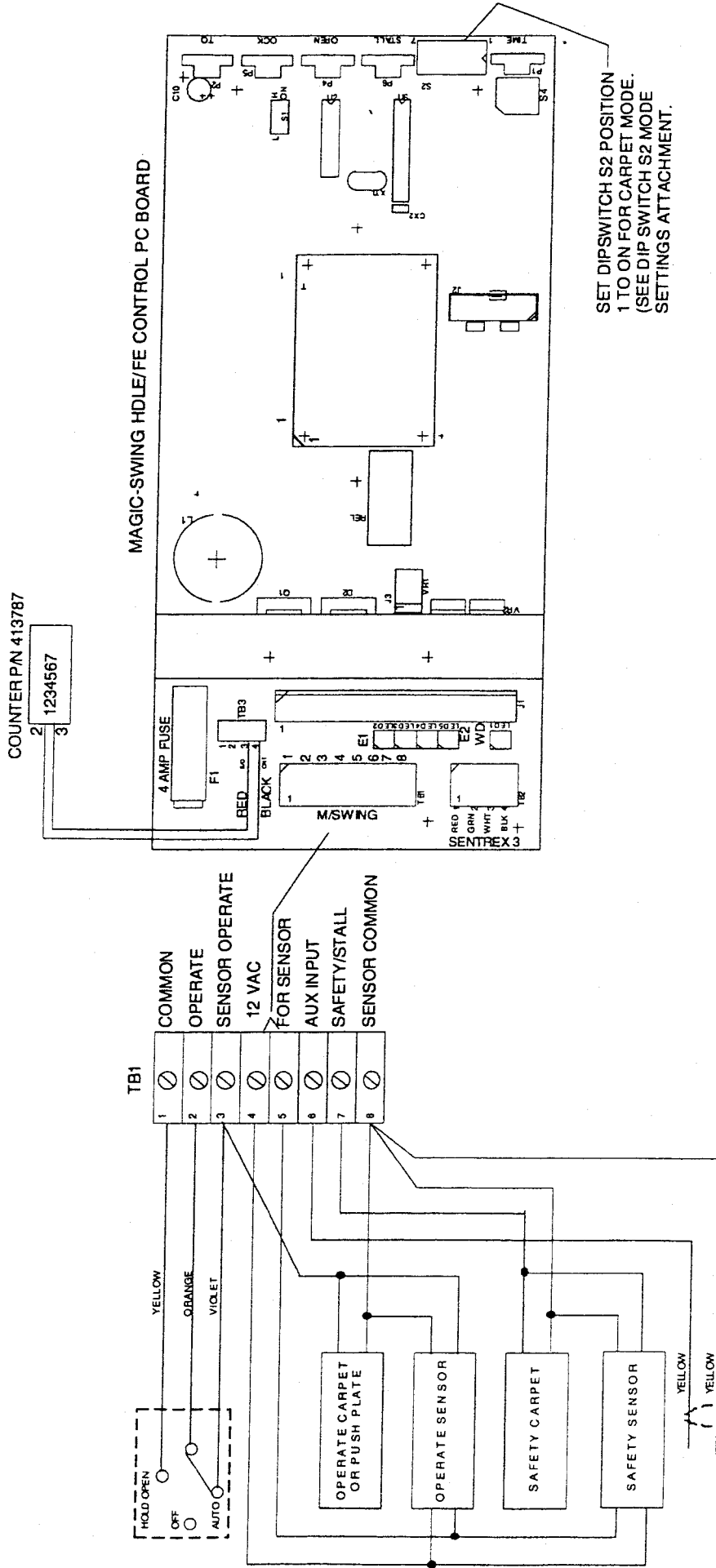

SET DIPSWITCH S2 POSITION
1 TO ON FOR CARPET MODE.
(SEE DIP SWITCH S2 MODE
SETTINGS ATTACHMENT.)

CONNECT YELLOW WIRES FROM PINS 3 AND 5
ON MOTOR / ENCODER HARNESS ACROSS
TB1, TERMINALS 6 AND 8.
REMOVE CONTROL BOX JUMPER WIRE
FROM TERMINALS 6 AND 8.

mca018

Attachment 4 Wiring Diagram—Magic-Swing Control Box with Sentrex³ (Sheet 1 of 1)

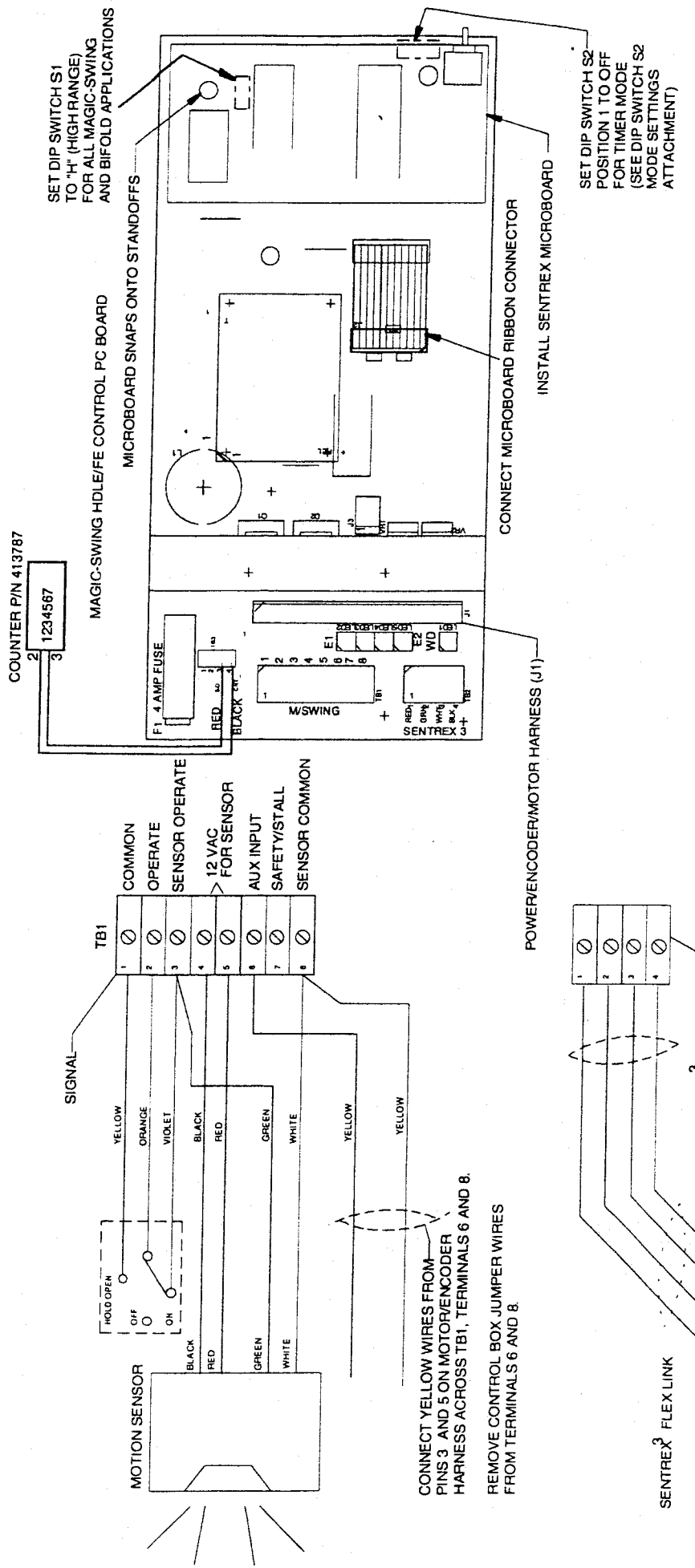

ncba007

Attachment 5 Wiring Diagram—Magic-Swing Control Box with Bifold Doors (Sheet 1 of 1)

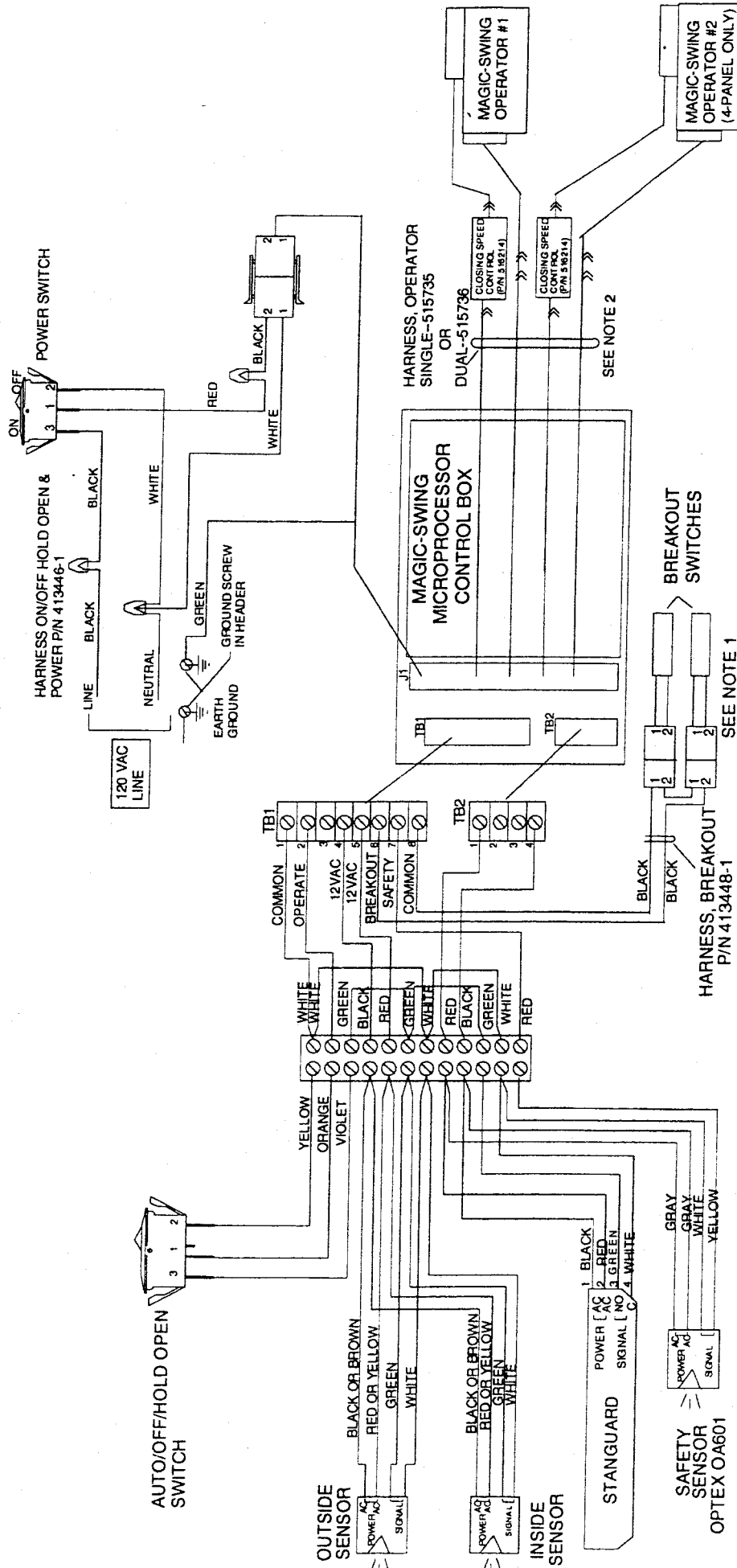

mcb011

NOTES:

1. SCHEMATIC SHOWS BREAKOUT SWITCHES FOR A 4-PANEL BIFOLD. IF A 2-PANEL BIFOLD IS USED, INSTALL 2-POSITION JUMPER 713410 IN PLACE OF SECOND MAGNETIC SWITCH.
2. OPTIONAL CLOSING SPEED AND POWER CLOSE MODULES MAY BE ADDED BETWEEN THE MAGIC-SWING CONTROL BOX AND THE MAGIC-SWING OPERATOR.
3. OPTIONAL ENCODER EXTENSION HARNESS, P/N 412449-1.
4. OPTIONAL MOTOR EXTENSION HARNESS, P/N 413411-1.
5. ALL SENSOR SIGNAL OUTPUTS ARE DEFINED WITH THE POWER ON.

Attachment 6
DIP Switch S2 Mode Settings
 (Sheet 1 of 2)

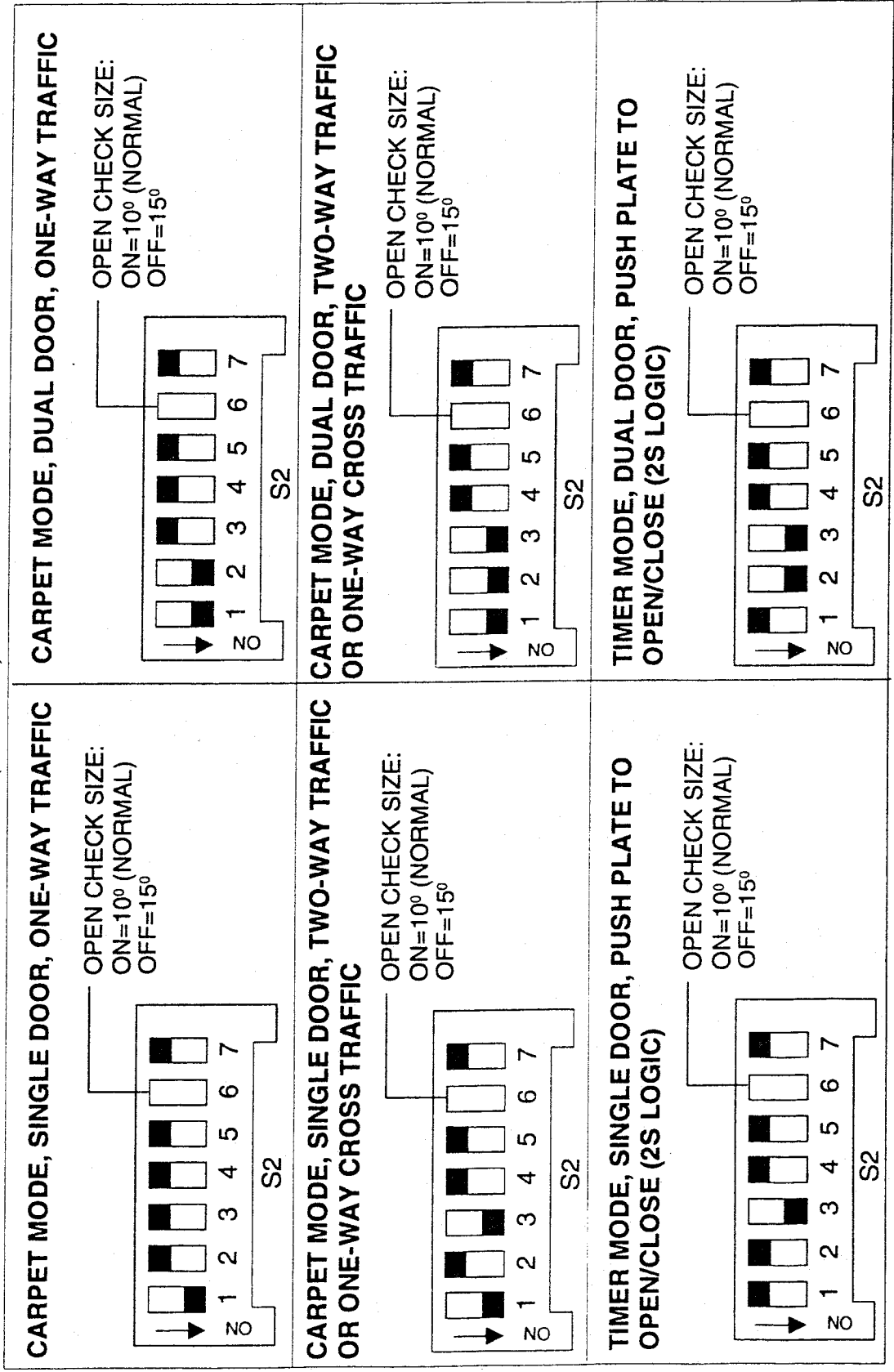

NOTE: BLACK INDICATES SWITCH POSITION.
 EXAMPLE: INDICATES SWITCH POSITION 1 IS SET TO ON.

mcb019

Attachment 6
DIP Switch S2 Mode Settings
 (Sheet 2 of 2)

TIMER MODE, SINGLE DOOR WITH SENTREX³
OR PUSH PLATES

MAGIC TOUCH (OPTIONAL):
 ON=ENABLED OFF=DISABLED

OPEN CHECK SIZE:
 ON=10° (NORMAL) OFF=15°

MAGIC TOUCH SENSITIVITY:
 ON=HIGH OFF=LOW

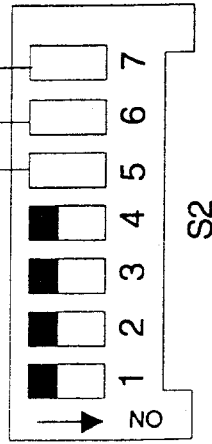

TIMER MODE, DUAL DOOR WITH SENTREX³
OR PUSH PLATES

OPEN CHECK SIZE:
 ON=10° (NORMAL)
 OFF=15°

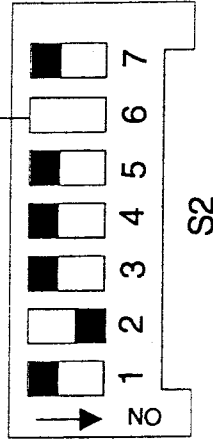

BIFOLD APPLICATION, SINGLE DOOR, TWO-PANEL

OPEN CHECK SIZE:
 ON=10° (NORMAL)
 OFF=15°

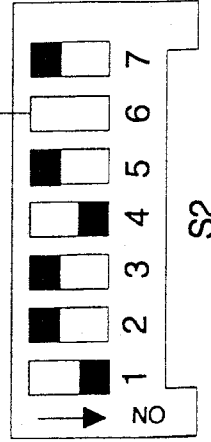

BIFOLD APPLICATION, DUAL DOOR, FOUR-PANEL

OPEN CHECK SIZE:
 ON=10° (NORMAL)
 OFF=15°

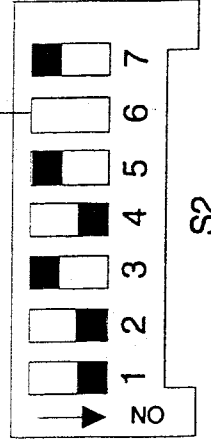

Attachment 7

Magic-Swing™ HDLE/FE Microprocessor Control Box

(Sheet 1 of 1)

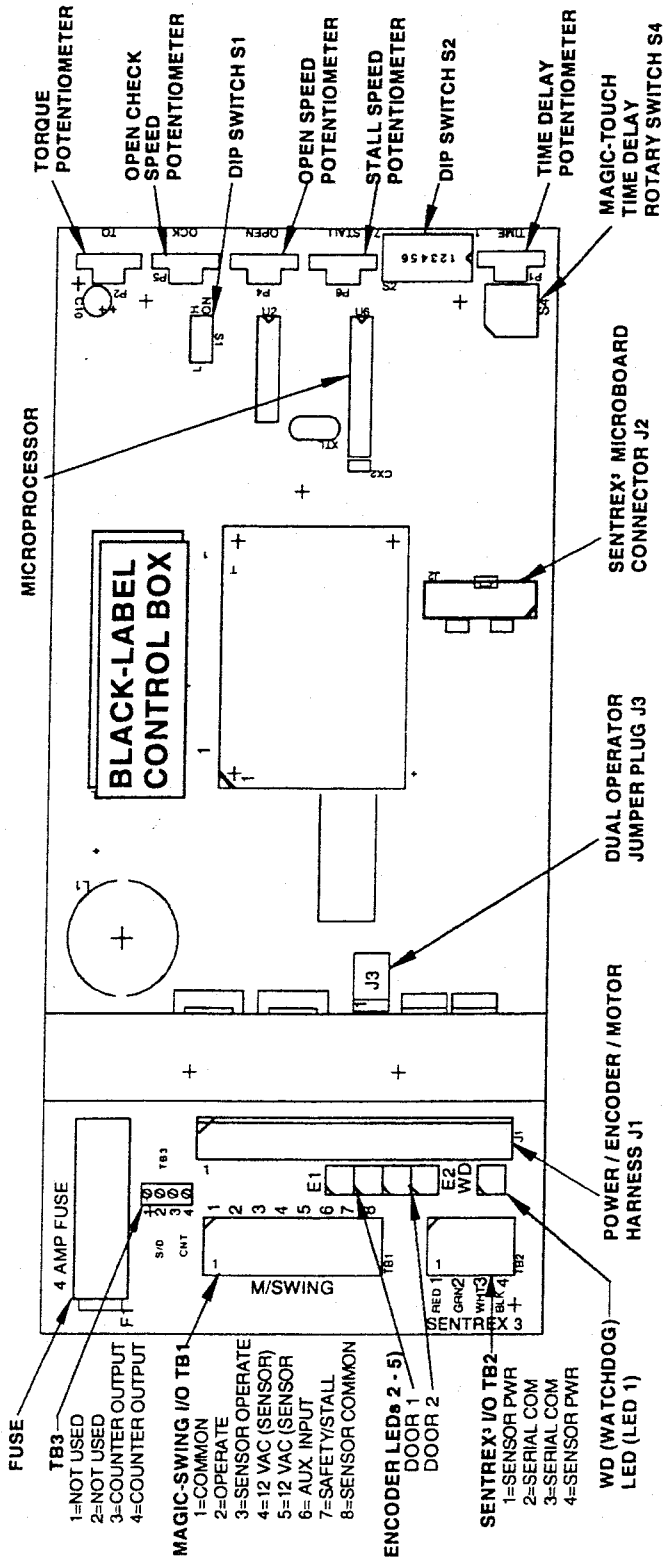

Position	Description
1	ON=Carpet, OFF= Timer
2	ON=Dual, OFF=Single
3	With position 1 ON (Carpet Mode): ON=Cancel "12-second delay without safety signal" OFF=Enable "12-second delay without safety signal" With position 1 OFF (Timer Mode): ON=2S logic on, OFF=2S logic off
4	ON=Bifold door, OFF= Swing door
5	ON=Magic-Touch™ on, OFF=Magic-Touch™ off
6	ON=10° open check, OFF=15° open check
7	ON=High Magic-Touch™ sensitivity OFF=Low Magic-Touch™ sensitivity

Position	Time Delay
0	5 Sec.
1	6 Sec.
2	7 Sec.
3	8 Sec.
4	9 Sec.
5	10 Sec.
6	12 Sec.
7	14 Sec.
8	16 Sec.
9	20 Sec.

DIP Switch S1
ON=High-speed range. Must be set to "H" (high range) for all Magic-Swing and bifold applications.

Torque Potentiometer
Clockwise=Increase door opening force Counterclockwise= Decrease door opening force

TECH TIP

Magic-Swing HDLE /FE Control Change

Prepared by: Dwight Reed

Engineer: Tony Ranuado

Reference Tech Tip: TT990804
TT990830

PCN: TBD

RDW: TBD

Summary Information

Product Information

Swing

Slide

Bifold

Competitor

Other

Panels / Hardware Operators / Drives Controls Sensors

Tech TIP Classification

Installation

Adjustment

Service

Clarifications

Design Change Description (Hardware/Software or Mechanical)

Retrofit/Upgrade Instructions

Frequently Asked Questions

Customer Complaints

Other

Release Information (initial and date)

Safety/Liability SG Engineering BF Technical Support JT Field Operations DR

Distribution (Complete TIP)

Customer Service

Field Operations

Technical Support

Training

Engineering

Distribution (Summary TIP)

Product Management

Manufacturing

National Sales

Operations Management

Regional Sales

Summary Description of the TechTIP

This TechTIP covers the following information:

1. Open check size clarification.
2. Bifold safety 12 second delay cancel
3. HDLE / FE Quick-Reference Guide #203959, Rev. A Attachment 6 switch illustration clarification.

If you have any questions concerning this procedure, contact
Access Technologies Technical Support, at 1-800-422-6489.

1. Open Check Size Setting Clarification (switch S2 position 6)

- **HDLE / FE Controls with serial numbers prior to d99 00042**
All Magic Swing HDLE / FE Controls are shipped with S2 position 6 in the off position. Switch S2 position 6 must remain in the off position on units with serial numbers prior d99 00042, giving an open check size of 15 degrees. Placing the switch S2 position 6 in the on position may cause the door to only open in a check speed. If an application requires a smaller check size of 10 degrees, a modified microprocessor IC can be field installed (see below). All HDLE / FE Controls shipped after date code serial number d99 00042, will allow the selection of the open check size from 10 or 15 degrees through switch S2 position 6.

- Replacement IC For HDLE / FE controls with serial numbers prior d99 0042

If an application requires a smaller check of 10 degrees, microprocessor IC with the modification can be field installed. This will allow the selection of the open check size from 10 or 15 degrees. A replacement microprocessor IC with capacitor can be ordered through the Rebuild department only. When placing an order you must specify "IC P/N 713783A with capacitor". There will be no charge for the IC providing the removed microprocessor IC is returned to the Rebuild Dept. in the provided container. HDLE / FE controls that are sent in for repairs will be updated with the current software and hardware revisions.

- Installing Replacement IC

The notch or polarity indicator on one end of the IC must face the speed potentiometers. Carefully align the IC pins with the holes in the socket. Press the IC carefully, but firmly, into the IC socket (see Figure 1).

IMPORTANT: Discharge any electrostatic charge that may be present by grounding (touching) yourself to the header prior to handling the IC. Avoid handling the IC pins.

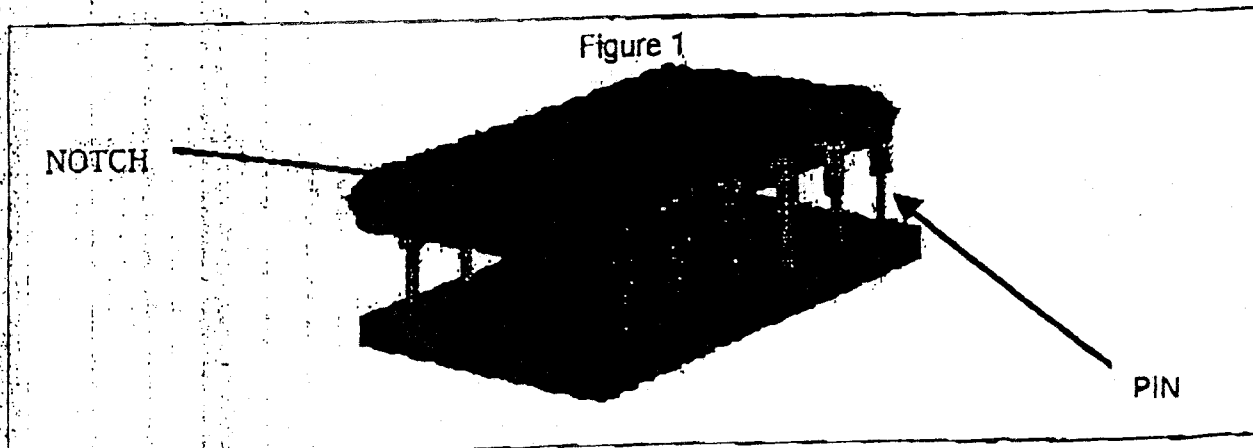

2. Bifold 12 Sec. Hold Open Delay Cancel Setting Clarification (switch S2 position 3)

- All Magic Swing HDLE / FE Controls are shipped with S2 position 3 in the off position. Bifold applications with two-way traffic patterns require switch S2 position 3 to be placed in the on position (see figure, 2). Placing the switch S2 in the off position will result in the doors remaining open for 12 seconds, after safety zone is clear.

3. HDLE / FE Quick-Reference Guide #203959, Rev. A Attachment 6.

- Disregard Attachment 6, S2 Switch position settings for Bifold applications of The Magic Swing HDLE / FE Microprocessor Control Box Quick-Reference Guide #203959, Rev. A, and Refer to *Figure. 2* below for proper switch S2 position settings for Bifold applications.

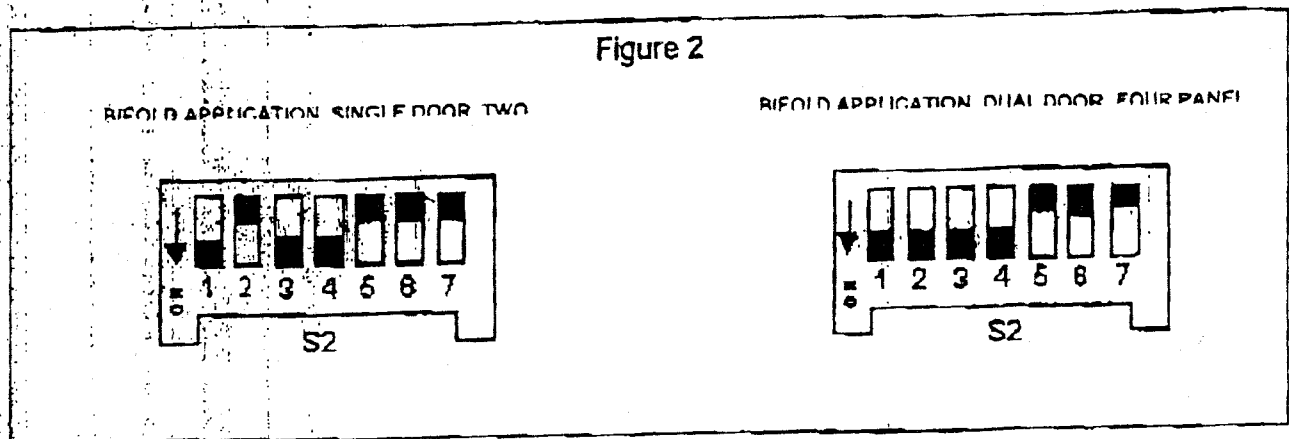

If you have any questions concerning this procedure, contact
Access Technologies Technical Support, at 1-800-422-6489.

