

# INSTALLATION TUNE-IN TROUBLESHOOTING

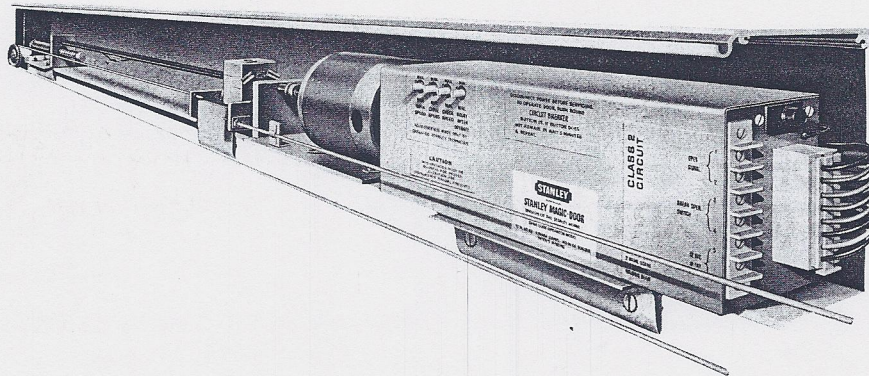

**DYNA-GLIDE OPERATOR IN  
WEATHER-WISE™ PACKAGES**

STANLEY MAGIC-DOOR

**STANLEY**

helps you do things right.®



# INSTALLATION OF OPERATOR

## A. MOUNT OPERATOR IN HOLES IN HEADER.

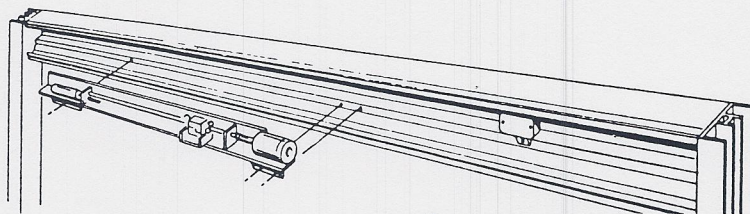

## B. SECURE ACTUATOR BLOCK TO SLIDING DOOR HANGER.

Shimming may be necessary to position actuator block correctly on drive shaft. Add or remove shims as may be necessary to raise actuator block to eliminate rocking without putting upward pressure on drive shaft.

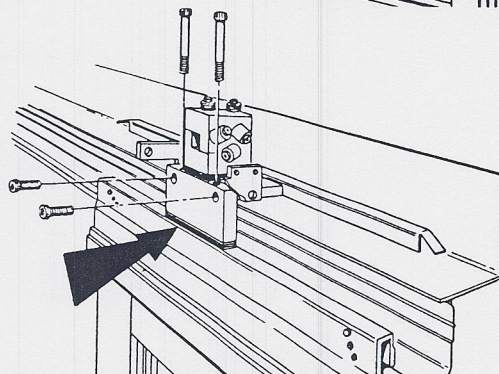

# INSTALLATION OF CABLES (BI-PART ONLY)

## A. SECURE CABLES (BI-PARTING PACKAGES ONLY).

1. Secure cable ends to slave sliding door as shown.
2. Route cables around pulleys in header.
3. Secure cables to actuator block as shown. Tighten cables to remove excess slack and center doors in the opening.

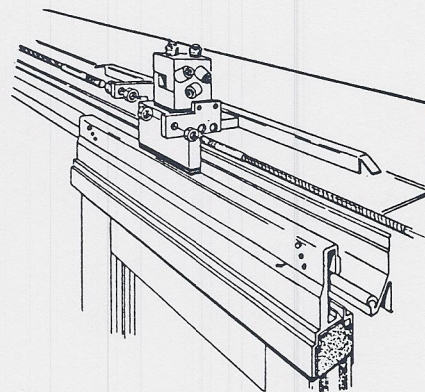
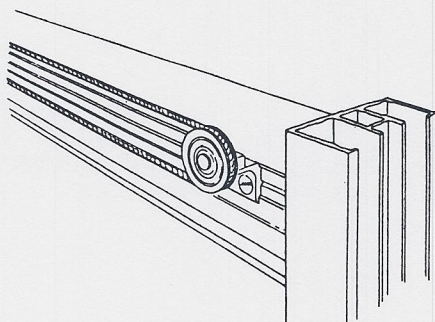
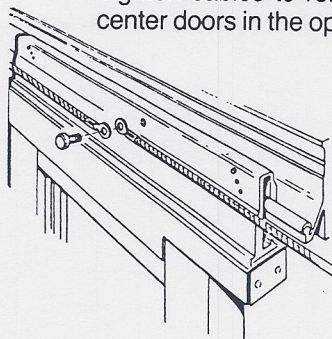

NOTE: The glazing material in both fixed and sliding panels of all sliding doors shall comply with the requirements in the performance specifications and methods of test for safety glazing materials used in buildings. ANSI Z 97.1 - 1975

## B. BEFORE INSTALLING CONTROL BOX AND MAKING ELECTRICAL CONNECTIONS, CHECK THE DOOR DRAG. DOES THE SLIDING DOOR MOVE WITH NO BINDING? MANUAL FORCE TO MOVE THE DOOR SHOULD NOT EXCEED 18 LBS. IF FORCE REQUIRED IS MORE, CHECK FOR THE FOLLOWING:

1. Bottom guides on sliding door(s)—binding, obstructions.
2. Are anti-risers too tight? If yes, readjust.
3. Make sure that carrier wheels are turning freely.
4. Check actuator and bearings for correct installation.
5. Check motor and motor brushes.
6. Make sure SX panels are not rubbing on O or SO panels.
7. Make sure that header cover is fully closed.



# ELECTRICAL CONNECTIONS

## A. INSTALL DYNA-GLIDE CONTROL BOX.

NOTE: The Dyna-Glide control box must be remotely located for 36" door packages. Use 514865 Harness.

## B. POSITION ALL LEADS ALONG THE TOP OF THE CONTROL BOX.

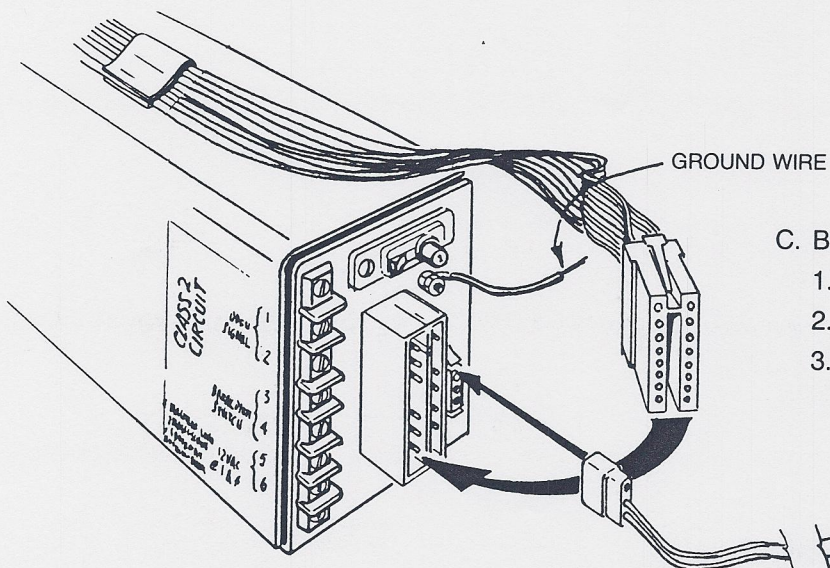

## C. BRING POWER TO CONTROL BOX.

1. Turn off power at main panel.
2. Secure ground wire on control box to power ground.
3. Wire nut two pin pigtail to 117 VAC power from junction box.

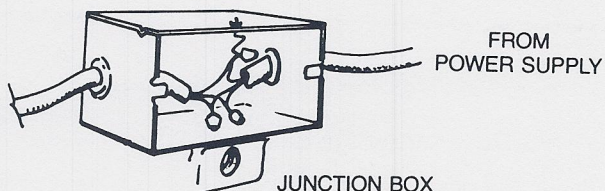

## D. SNAP 16 PIN CONNECTOR, FROM OPERATOR, TO CONTROL BOX.

NOTE: White and gray wire from 16 pin connector are used for the optional reduced opening switch. If you are not installing this switch, be sure these two wires are wired gray to gray and white to white. If you are installing the optional switch, see page 3.

## E. CONTROL BOX—TERMINAL CONNECTIONS

1. Controls—mats, magic-scan, etc., to terminals 1 & 2.
2. Secure breakout switch leads to terminals 3 & 4.

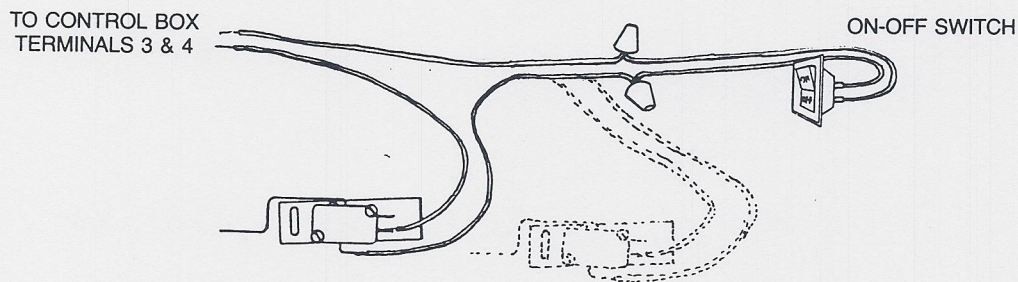

ON BI-PARTING PACKAGES—The two breakout switches must be wired in series.

3. Terminals 5 & 6 provide a 12 VAC power tap for magic-scan and doorway holding beam ONLY.

An automatically resettable circuit breaker mounted inside the control box protects the 12 VAC circuit (at terminals 5 & 6). If an accidental short circuit occurs at these terminals, the voltage will be restored automatically after removal of the cause of short circuit . . . . after a wait of approximately 30 seconds.



# OPTIONAL REDUCED OPENING SWITCH

1. WIRE NUT TWO LEADS FROM THIS SWITCH TO THE GRAY AND WHITE LEADS LOCATED IN THE 16 PIN CONTROL BOX CONNECTOR.

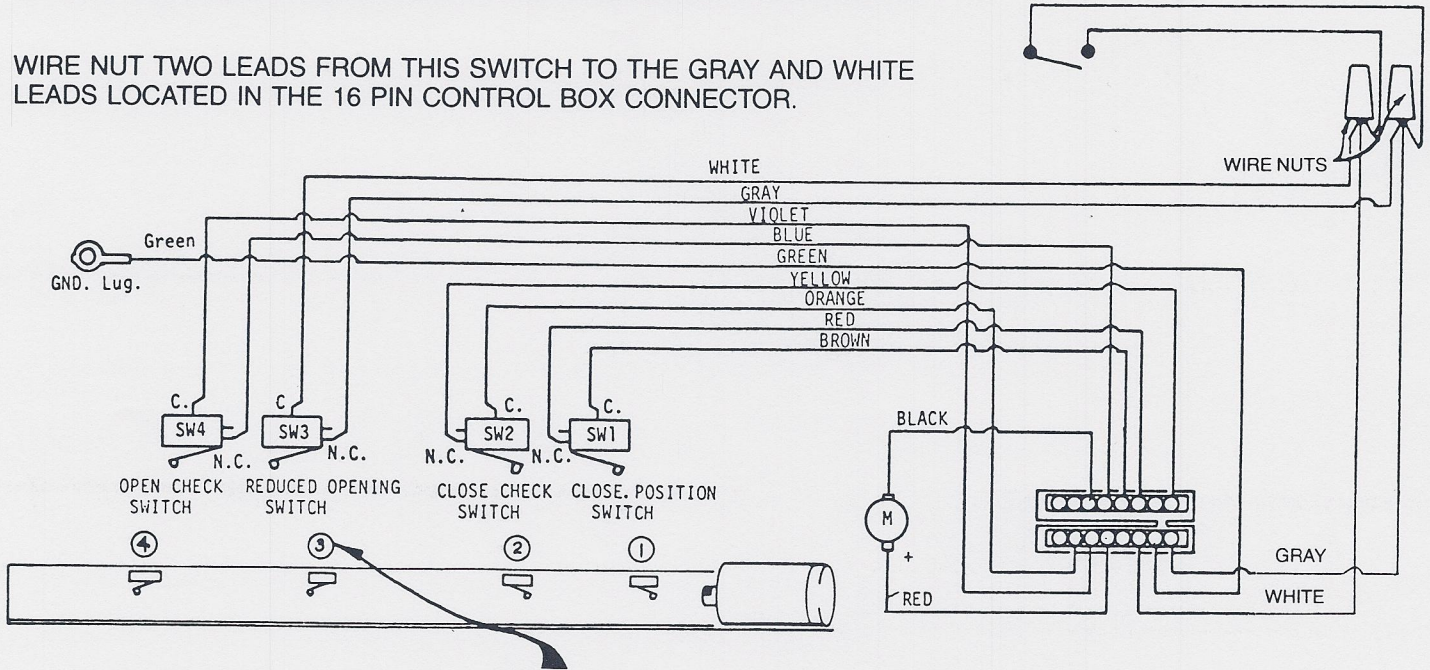

REDUCED OPENING SIZE (Suggested).

1. Locate switch to proper opening size.
  - a. 39" for 44" Door Package
  - b. 32" for 48" Door Package
  - c. 39" for 60" Door Package
  - d. 39" for 72" Door Package

NOTE: Reduced opening is not available for 36" door packages.

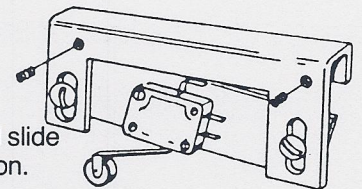

Loosen set screws and slide switch to desired position.

Switches 1-4 are all mounted on the same type bracket and are adjustable.

**WEATHER-WISE™ 4000 ES** Located in the lead stile of the right hand interior fixed panel or "P" panel on

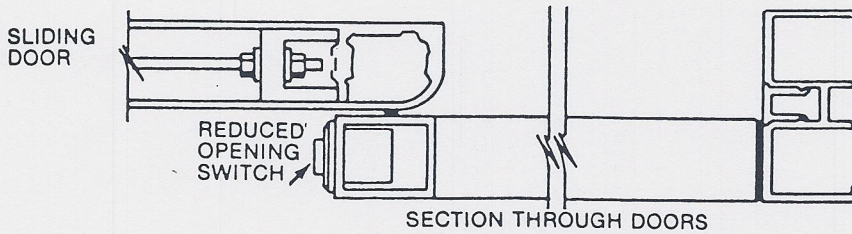

**WEATHER-WISE™ 8000** Located in the right hand jamb on the swing up cover side.

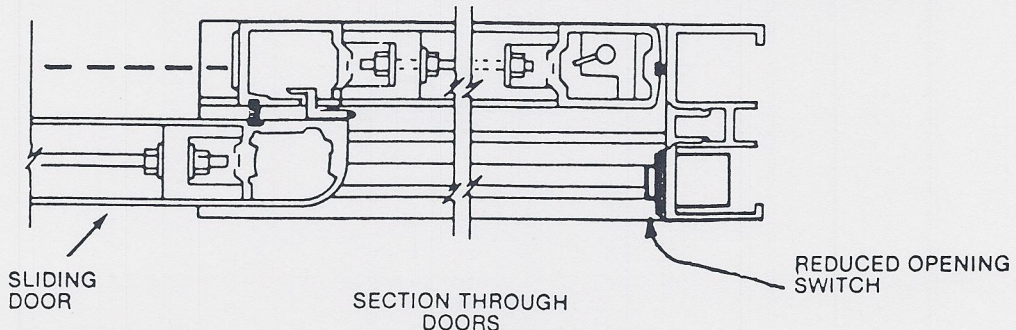



# TUNE-IN AND ADJUSTMENT

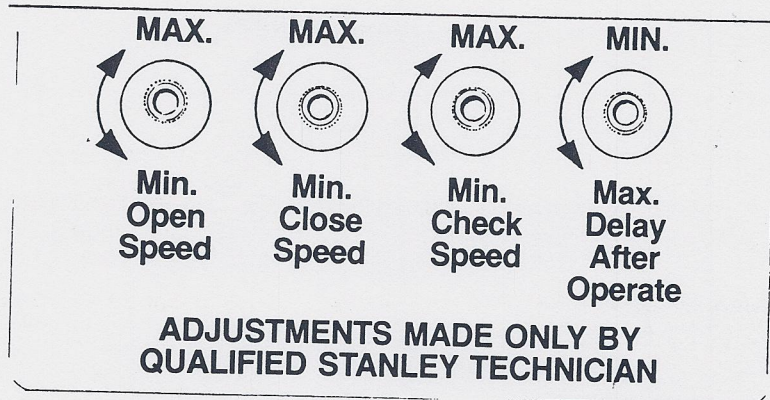

- Set the 4 adjustment pots on the control box to minimum.
- Turn on main power.
- Push circuit breaker button—in for on position.
- Turn toggle switch, junction box, on and be sure door package on/off switch is on.
- Adjust speeds as follows:

Position a tape measure on the floor near the lead edge of the sliding door, cycle the door and increase or decrease pot settings until recommended door speeds are attained.

Open Speed—2 ft/sec. max not to exceed.

Close Speed—1 ft/sec. max not to exceed.

The open check speed is not independently adjustable but is controlled by the close speed pot. (Opening check speed will be approximately 20% less than the closing speed.

Close Check—3-6 in./sec.

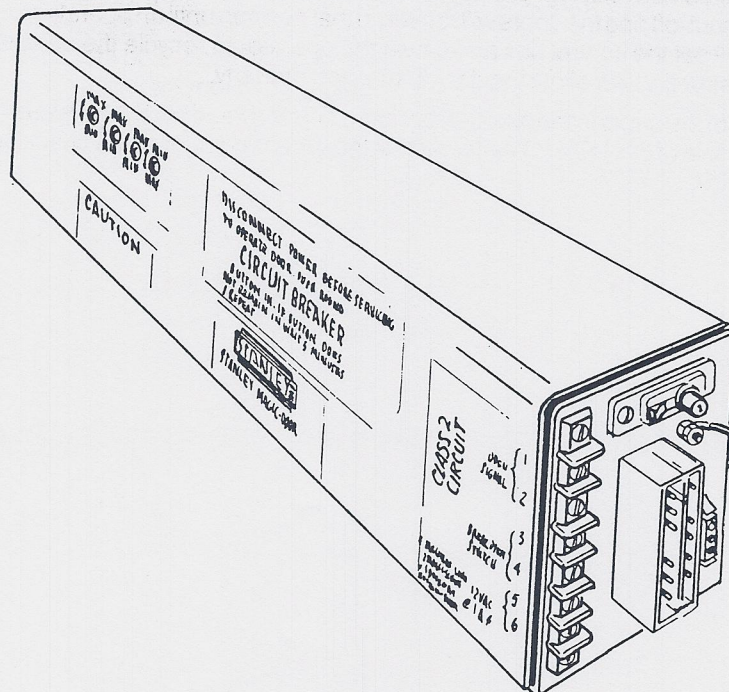



# FUNCTIONAL DESCRIPTION

## OPEN CYCLE

Upon operate signal, the door will open at a speed adjustable by the "open speed" pot. When the actuator trip rod contacts the open check switch, the door will slow down. The door will continue to open until stopped by the checking cylinder.

NOTE: *There is no open limit switch;* door will open to the checking cylinder and stall. This stall condition will not harm operator nor control box.

## TIME DELAY

With the "delay after operate" pot set to "min" the doors will start to close approx. 1/2 second after loss of operate signal. If a longer delay is required, adjust the "delay after operate" pot up to the required time delay.

NOTE: If used with Magic Scan III, the time delay in the Magic Scan III will *add* to the Dyna-Glide time delay.

## CLOSE CYCLE

Upon expiration of time delay, door will close at a speed adjustable by the "close speed" pot. When the actuator trip rod contacts the close check switch, the door will slow down. The door will continue to close until fully closed.

NOTE: *There is no close limit switch.*

The door will close to fully closed and stall. This stall condition will not harm operator nor control box, and will last for approximately 9 seconds after which power to the motor will shut off. The close position switch does *not* shut off the motor, its function is to re-start the motor to close the door if the door is slid open manually.

## FINAL CHECK

- A. Check emergency breakout. Emergency breakout must shut off the power to the operator.
- B. Check the doorway holding beam. Place your hand in front of the unit. This will cause the door(s) to open and remain open until your hand is removed.
- C. If the door is prevented from closing, power will continue to be applied to the doors for 12 seconds. After 12 seconds, power is shut-off and the doors will remain in that position until an operate signal is given. Input of an operate signal will reset the control box and cause the operator to recycle the door(s) to the open position. Removal of the obstruction will allow the door to function properly.
- D. Check the position of the doors in the full open position. There should be 1 1/4" between the lock stile of the SX panel and the lead stile of the SO or O panel. Adjust the rubber bumper of the checking cylinder out until this clearance is obtained.



# TROUBLESHOOTING

BEFORE REFERRING TO THE TROUBLESHOOTING CHART MAKE SURE THAT:

1. There is power. Check the circuit breaker at the main circuit panel.
2. SX panels are tightly closed.
3. There is not a mechanical bind in the sliding door. Disconnect power. Disconnect operator linear actuator and cables from the door. Manually slide the door open and closed. If the sliding door does not move freely, correct bind and/or drag.

NOTE: It is important that the header cover be closed. An open header cover will create header sag and increase the chance of door drag.

CAUTION: Always disconnect power before inspecting linear actuator and other moving parts of the operator.

Trouble	Test	Cause	Remedy
<b>A. Door will not open when opening carpet is actuated. Motor does not run and control box relays do not energize.</b>  <b>Measure voltage into control box at 3 pin plug.</b>	1. Check on/off switch located on door package.	Switch is off.	Place switch in "on" position.
	2. Check circuit breaker on control box.	Circuit breaker tripped.	Push circuit breaker into "on" position.
	3. Set VOM to 120 volts ac scale. If meter does not read 117 volts . . . .	Power supply has been interrupted. Circuit breaker at main panel tripped.	Reset main panel breaker.
	4. Place jumper across terminals 1 & 2 of control box terminal strip. If door opens . . . .	Scan leads are open, carpet or carpet leads are open, defective DHB.	Replace scan and/or leads. Replace carpet and/or leads. Replace DHB.
<b>B. Door will not open when opening carpet or scan is actuated. Motor does not run.</b> <b>. . . continued</b>	1. Turn off power. Disconnect breakout switch leads from terminals 3 & 4 of terminal strip at control box. Check for continuity with VOM meter. If reading is infinite ohms . . .	Break out switches and/or leads are open.	Replace switch or switches and check switch leads for open lead. Rewire if necessary. NOTE: Leads should be securely connected to terminals 3 & 4.
	2. Turn off power. Disconnect 16 pin connector plug from control box. With VOM check ohms reading across socket 10 (red lead) & 11 (black lead) of female plug. Meter should read between 13 ohms & 16 ohms. If it reads infinite.	Motor failure.	Replace motor.
<b>C. Door will not open. Motor does not run, relay energizes.</b>	1. Interchange relays. If door opens.	Faulty relay.	Replace replay.
	2. If door does not open after relays are interchanged.	Faulty control box.	Replace control box.
<b>D. Door does not open. Motor runs.</b>	1. Check set screws attaching coupling to shaft.	Set screws loose.	Tighten set screws & apply loctite.
	2. Visually check coupling for damage.	Coupling damaged.	Replace coupling.



# TROUBLESHOOTING

Trouble	Test	Cause	Remedy
<b>E. Door opens fully, motor cuts off, but door will not close.</b>	1. Interchange relays, closing relay with opening relay. If door closes . . .	Faulty closing relay.	Replace closing relay.
	2. Disconnect carpet or scan leads from terminals 1 & 2 of terminal strip. If door closes . . .	Shorted carpet(s) or scans. Check wiring.	Replace carpet(s) replace scans (if wiring OK).
<b>F. Door opens, starts to close &amp; then recycles.</b>	1. Check that carpet or scan leads are connected to terminal 3 & 4 of low voltage terminal strip.	Carpet leads not wired correctly. Scan misadjusted.	Wire carpet leads to terminal 3 & 4 of low voltage terminal strip.
<b>G. Door slams on opening cycle.</b>	1. Turn close speed adjustment CCW & check cylinder adjustment CW (open check is a function of close speed).	Close speed & checking cylinder not properly adjusted.	Readjust closing speed & checking cylinder. See tune-in section.
<b>H. Door slams on closing cycle.</b>	1. Turn closing check adjustment CCW.	Closing check not properly adjusted.	Readjust closing check. See tune-in section.
<b>I. Circuit breaker continues to trip</b>	1. Turn off power. Disconnect 16 pin connector plug from control box with VOM check socket 10 (red lead) to ground & socket 11 (black lead) to ground. If either reads "0" ohms.	Motor lead(s) shorted to metal.	Route motor leads away from metal and tape.
	2. Disconnect door from operator. If the door does not slide freely.	Door is dragging on threshold.	Adjust door so that it moves freely.
<b>J. Door remains open too long.</b>	1. Turn time delay to min. Open delay should not exceed 1/2 sec.	Time delay is increased.	Readjust time delay on control box.
<b>K. No output from 12 VAC tap.</b>	1. Check output with VOM.	Automatic resettable circuit breaker has "blown." Remove cause of short. Wait approximately 30 seconds, voltage should return.	
<b>L. Door does not close completely.</b>	1. Turn check speed pot to max.	Too much door drag.	Find drag and relieve.