

Stanley Access Technologies
Quick-Reference Guide



Dura-Care™ Series 7200TL-FBO Sliding Door
Installation Instructions
Quick-Reference Guide
204072
Rev. D, 09/06/12

Prohibition on Copying

Any unauthorized reproduction, disclosure or distribution of copies by any person of any portion of this work may be a violation of copyright law of the United States of America and other countries, could result in the awarding of statutory damages of up to \$250,000 (17 USC 504) for infringement, and may result in further civil and criminal penalties. All rights reserved.

Quick-Reference Guide

TABLE OF CONTENTS

1. PURPOSE 2

2. PREREQUISITES 4

3. INSTALLATION INSTRUCTIONS 4

3.1 Checking the Rough Opening 4

3.2 ATTACH jambs to the header. 5

3.3 Installing the Header and Jamb Assembly 6

3.4 Installing the Bottom Pivot Plate 7

3.5 Installing the SO Panel..... 8

3.6 Installing the SX Door Panel 10

3.7 Performing Final Adjustments 15

3.8 Installing the Latch Assembly..... 19

3.9 Installing Self Closure/Damper Kit (Optional) 19

3.10 Performing the Closeout Procedure 22

3.11 Proper Glass Blocking of Door 22

Attachments

Attachment 1, Documents, Definitions, Tools, Equipment, Materials, and Consumables 24

Attachment 2, Replacement Parts 25

WARNING

Proper glass blocking is CRITICAL to ENSURE proper door function. See Section 3.11 for proper glass blocking instructions OR refer to Stanley Access Technologies p/n 203626 “Proper Blocking of Swinging and Sliding Doors Installation Instructions.”

1. PURPOSE

1.1 Discussion

This manual provides installation instructions for the Stanley Dura-Care Series 7200 trackless door with full breakout (TL-FBO). The Series 7200TL-FBO is a two-panel manual door system. See Figure 1.

Figure 1. TL-FBO Assembly

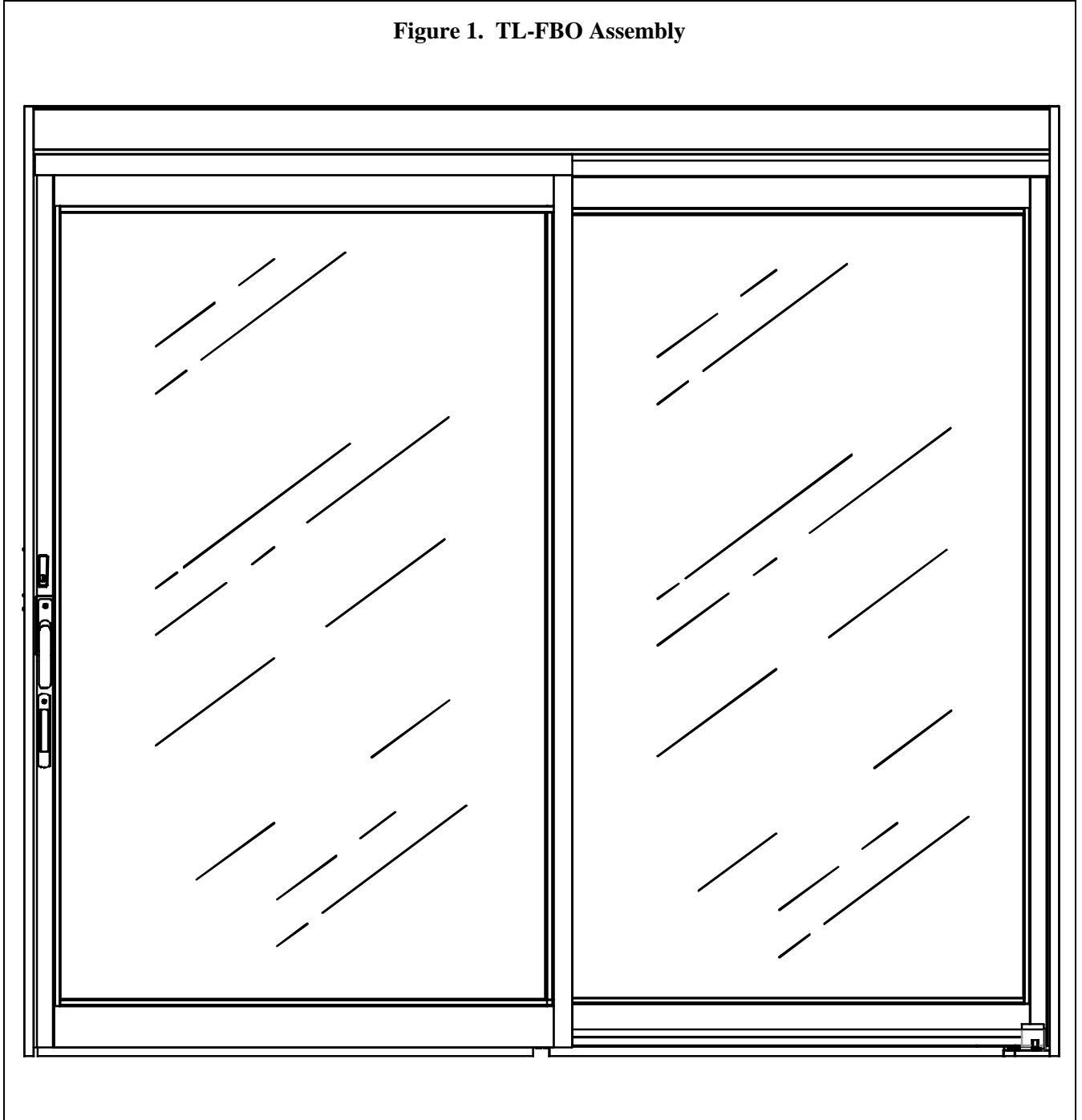

With the ICU smoke and draft control option kit installed, the air leakage rates shown in Table 1 can be achieved.

Table 1. Air Leakage Rates

Pressure (in. of WC)	Air Temp, °F	Leakage (cfm/sq ft)	Closing Force, lb	Artificial Bottom Seal
0.05	Ambient	1.5	3.8	No
0.10	Ambient	2.1	3.8	No
0.20	Ambient	3.20	3.8	No
0.30	Ambient	4.22	3.8	No
0.05	400	0.28	3.8	No
0.10	400	0.77	3.8	No
0.20	400	1.21	3.8	No
0.30	400	1.70	3.8	No

Pressure (in. of WC)	Air Temp, °F	Leakage (cfm/sq ft)	Closing Force, lb	Artificial Bottom Seal
0.05	Ambient	0.532	3.8	Yes
0.10	Ambient	0.777	3.8	Yes
0.20	Ambient	1.4	3.8	Yes
0.30	Ambient	1.7	3.8	Yes
0.05	400	0.0709	3.8	Yes
0.10	400	0.340	3.8	Yes
0.20	400	0.51	3.8	Yes
0.30	400	0.80	3.8	Yes

1.2 Applicability

This manual is applicable to the Stanley Dura-Care Series 7200TL-FBO sliding door system. This manual does not cover retrofit of an existing door system.

204072
Rev. D,09/06/12
3 of 26

2. PREREQUISITES

- 2.1 Protective barrier (caution/warning tape) has been set up to prevent unauthorized access to work area.
- 2.2 Attachment 1 has been reviewed for the following:
 - a. Definitions of the terms used in this procedure
 - b. A listing of the additional documents required during this procedure
 - c. A listing of the tools, equipment, materials, and consumables used in this procedure.

3. INSTALLATION INSTRUCTIONS

3.1 **Checking the Rough Opening**

- 3.1.1 ENSURE floor is level across the entire opening.

NOTE

Opening width should be package width plus $\frac{1}{2}$ " ($\frac{1}{4}$ " each side for shim and caulk clearance). This clearance can be as small as $\frac{1}{8}$ " for a tight appearance with the aluminum storefront construction.

- 3.1.2 CHECK opening width and height from finished floor.
- 3.1.3 ENSURE area is clean and clear of debris.
- 3.1.4 **IF the smoke and draft kit is required**, then refer to Figures 2 and 3, and PERFORM the following:
 - a. Refer to Figure 2, and REMOVE three bolts and washers securing the fixed rail to the header, and REMOVE the fixed rail.
 - b. CUT the SO panel top seal to the length of the SO panel fixed rail.
 - c. Using glass cleaner or isopropyl alcohol, CLEAN the header lip in the area where the SO panel will touch.
 - d. APPLY adhesive backed seal to the header lip behind the fixed rail.

Figure 2. Removing the Fixed Rail from the Header

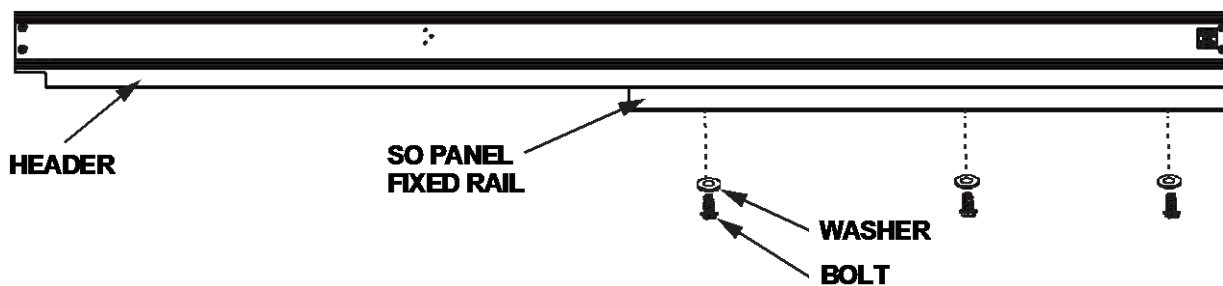
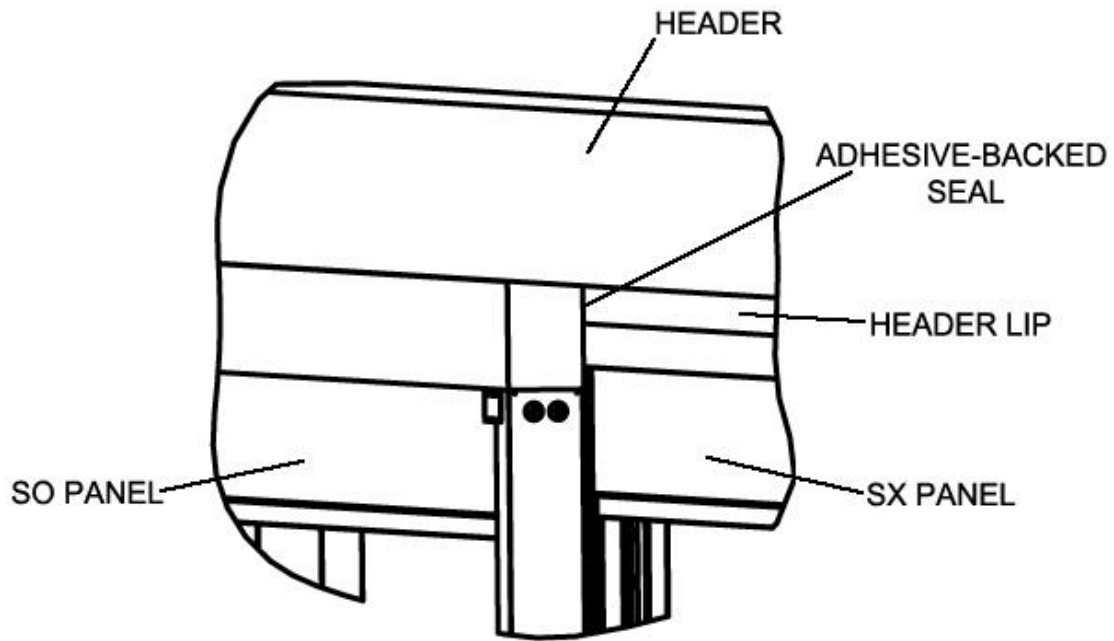

Figure 3. Preparing the Header for the Adhesive-Backed Seal



NOTE

Jamb mounts are fastened to the jambs at the factory.

3.2 ATTACH jambs to the header.

Figure 4. Attaching the Jambs to the Header

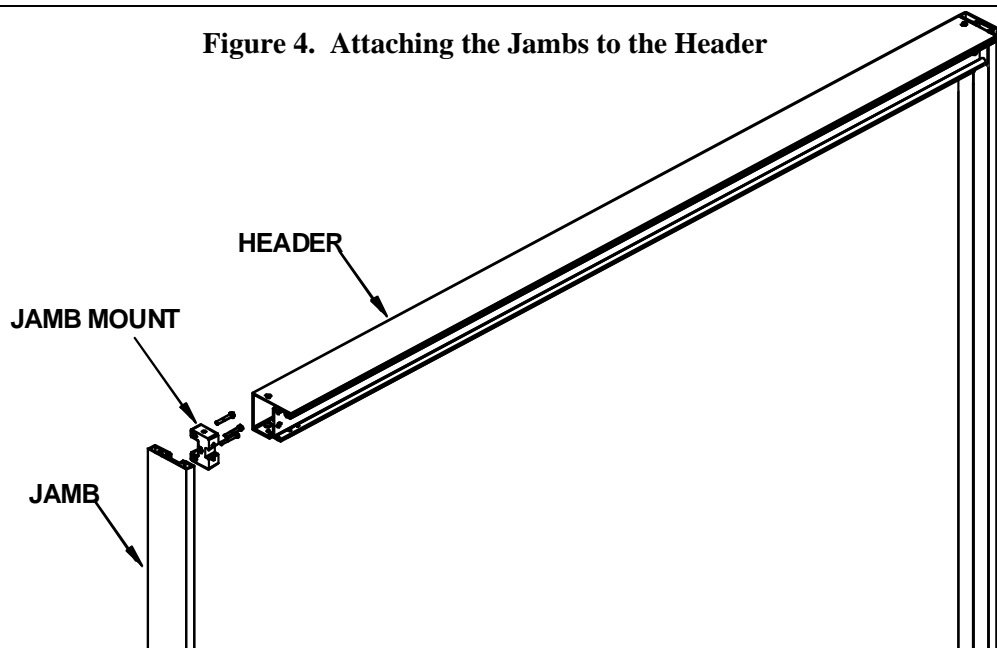

204072
Rev. D,09/06/12
5 of 26

- 3.2.1 Refer to Figure 4. Using 1/4-20 X 1 3/4" screws, ATTACH header to jamb mount.
- 3.2.2 POSITION end of header extrusion over the header bracket.
- 3.2.3 Using four 1/4-20 X 3/4" CS screws, ATTACH header to header bracket.
- 3.2.4 REPEAT for opposite end of header.
- 3.2.5 **IF the smoke and draft kit is installed**, Refer to Figure 2, and, using the three bolts and washers, FASTEN the SO panel fixed rail to the header.

3.3 Installing the Header and Jamb Assembly

NOTE

When determining the proper orientation of the header cover, the header cover must open in the same direction that the door breaks out. For example, if the header cover opens to the inside of the building, the door will break out to the inside.

- 3.3.1 DETERMINE proper orientation of header cover with respect to breakout direction.
- 3.3.2 LIFT header and jamb assembly and POSITION into opening.
- 3.3.3 Temporarily SECURE frame in place as necessary to prevent header and jamb assembly from falling.
- 3.3.4 SHIM beneath jamb(s) as necessary to level header and maintain required height from highest point of finished floor.
- 3.3.5 INSPECT one jamb for plumb in vertical and horizontal planes. IF required, SHIM back of jamb.
- 3.3.6 Refer to Figure 5 AND Table 2. Using the previously drilled jamb holes as a guide, DRILL holes in rough opening for the following fasteners as required:

Table 2. Jamb Installation Fastener Size and Type

Rough Opening	Fastener size/type	Embedded minimum depth
Concrete	concrete screw	1 1/2"
Steel	#14/SMS (18 GA steel minimum)	As necessary
Wood	#14/wood screw	1 1/2"

Figure 5. Installing the Header and Jamb Assembly

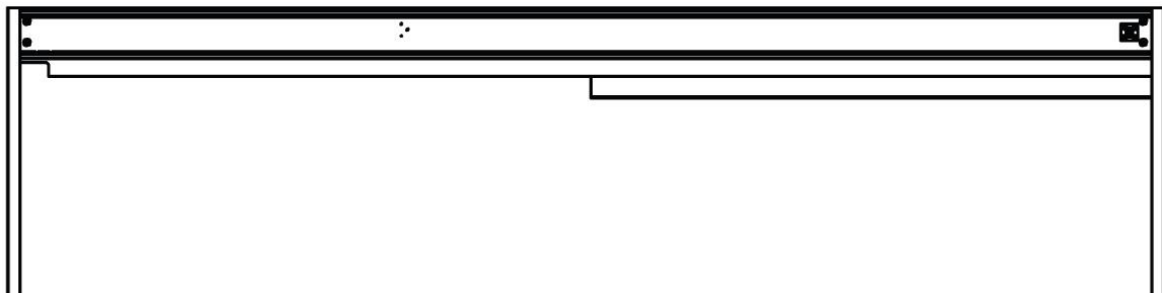

- 3.3.7 INSTALL, but do *not* tighten, fasteners securing one jamb to opening, and ENSURE jamb remains plumb.
- 3.3.8 REPEAT for opposite jamb.
- 3.3.9 Starting at the top of jamb and moving downward, SHIM jambs as necessary to ensure jambs remain level and plumb, and TIGHTEN fasteners securing jambs to opening.
- 3.3.10 INSTALL and TIGHTEN fasteners securing header to opening, and ENSURE header remains level.
- 3.3.11 INSTALL jamb inserts.

3.4 Installing the Bottom Pivot Plate

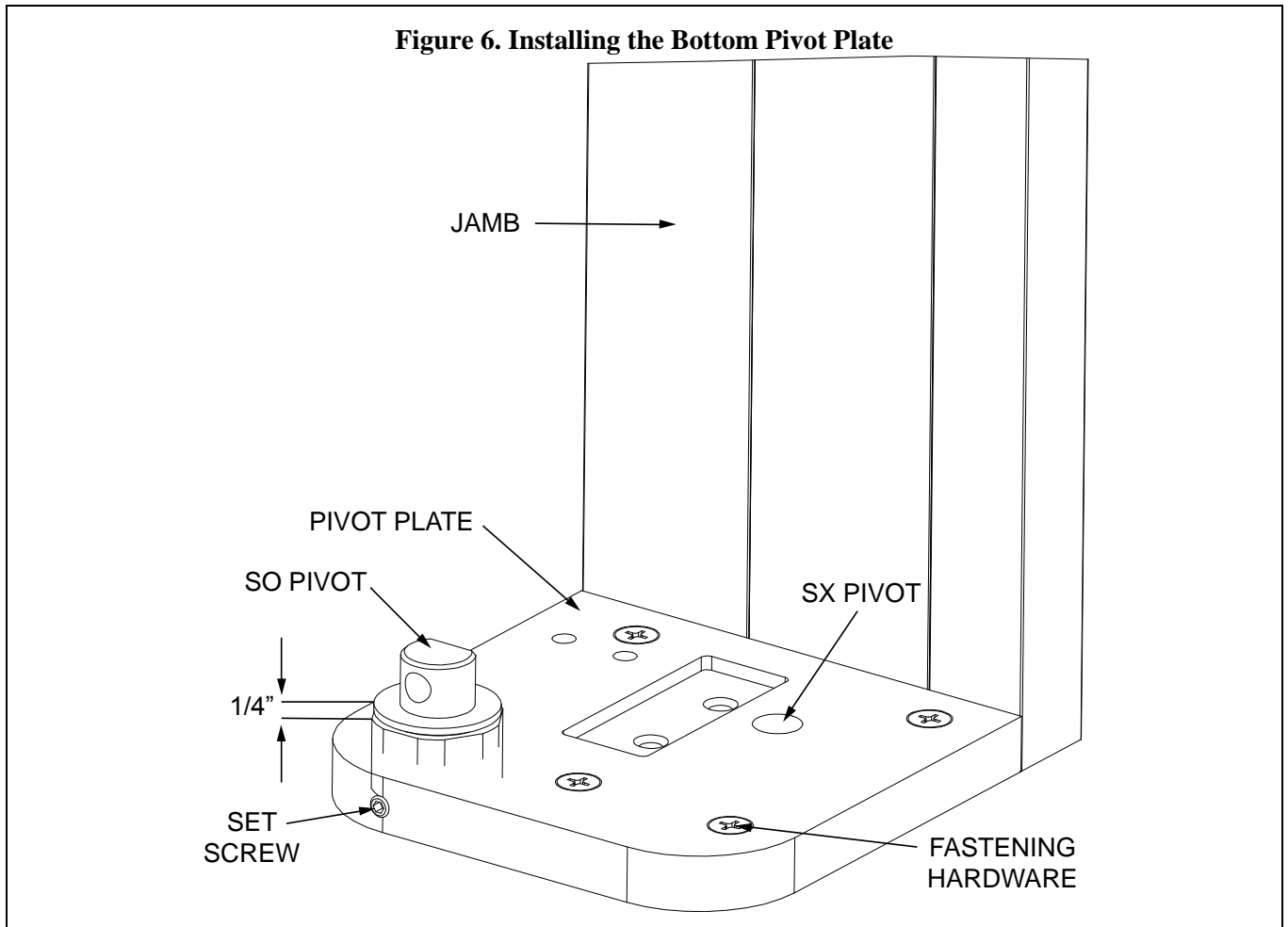

- 3.4.1 Refer to Figure 6, and THREAD the SO pivot into the pivot plate such that the top of the adjusting screw shoulder is $\frac{1}{4}$ " above the top of the plate.
- 3.4.2 Refer to Figure 6 and ALIGN the pivot plate to the jamb.
 - a. ENSURE that the SO pivot is plumb with the SO pivot hole in the fixed rail.
 - b. Using the predrilled countersunk holes in the bottom pivot plate as a guide, DRILL bottom pivot mounting holes into floor.
 - c. FASTEN the pivot plate to the floor.

204072
Rev. D,09/06/12
7 of 26

3.5 Installing the SO Panel

NOTE

If installing Privacy Glass, reference to Stanley document number 204085.

3.5.1 INSTALL glass into the SO panel.

3.5.2 ENSURE glass stops correctly positioned with respect to the door application.

NOTE

The SX panel bottom sweep is installed in the bottom rail at the factory.

3.5.3 Refer to Figure 7 and INSTALL the SO bottom sweep into the bottom rail if bottom sweep option is selected.

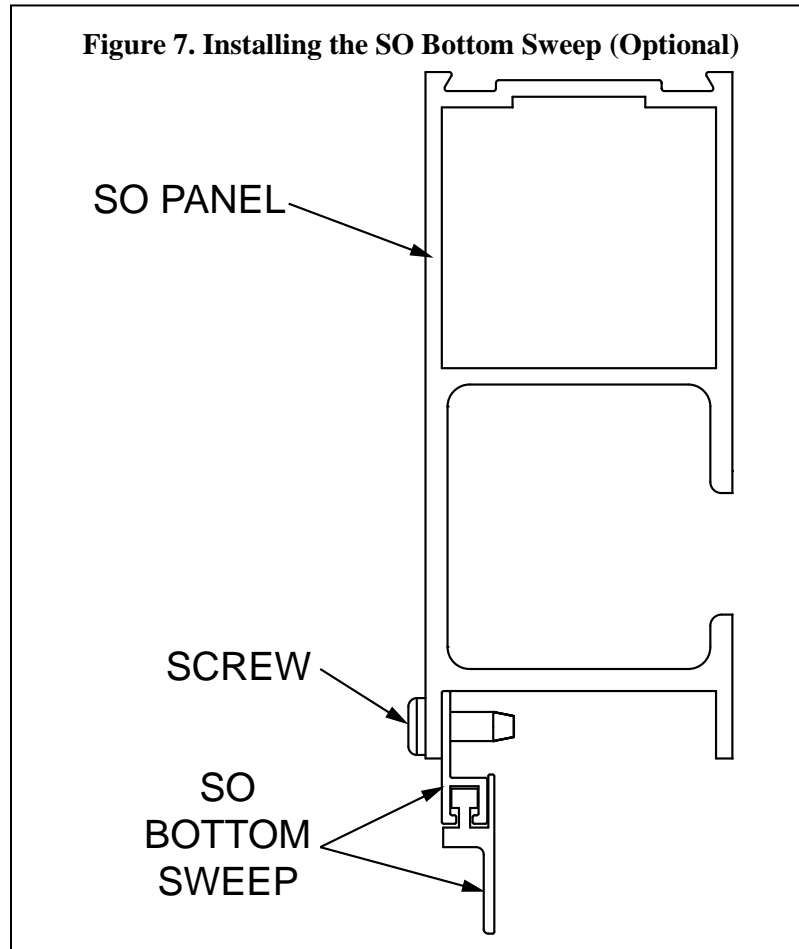

3.5.4 INSTALL weatherstrip on SO pivot stile and on face of lead SO stile.

3.5.5 INSTALL the SX/SO – Panel Stile Overlap Seal

- Refer to Figure 8, and using Windex or isopropyl alcohol, CLEAN the SO/SX-panel lead stile surface that overlaps the SX pivot stile.
- INSERT the overlap seal (bubble shape) into the slot on the face of the lead SO and pivot SX stile.
- PEEN the overlap seal slot on both ends.

204072
Rev. D,09/06/12
8 of 26

Figure 8. Installing the SO/SX- Panel Stile Overlap Seal

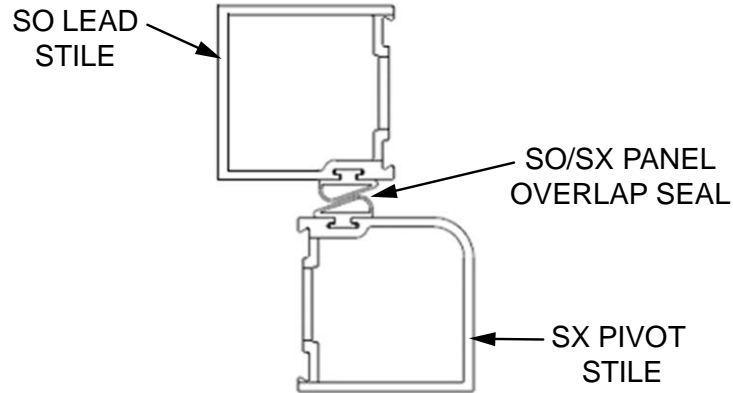

NOTE

If necessary, apply soapy water to the back of the seal for ease of installation.

- 3.5.6 TURN the SO pivot and ENSURE that the pivot flat is parallel with the header.
- 3.5.7 POSITION SO panel vertically and perpendicular to the header.
- 3.5.8 POSITION bottom of panel onto the bottom pivot, and ENSURE the following:
 - a. The SO pivot flat aligns with the cleat in the bottom rail.
 - b. The bottom rail is pushed firmly against the SO pivot

Figure 9. Installing the SO Panel

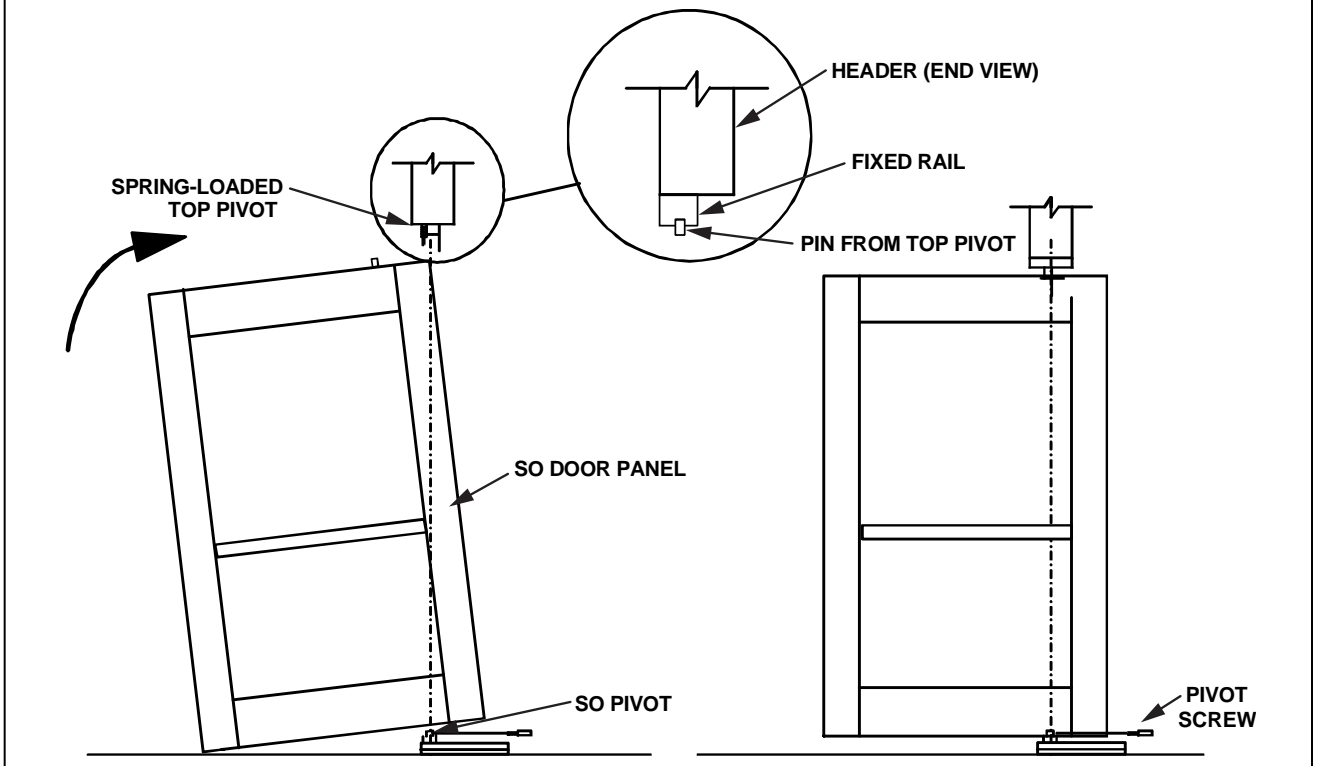

204072
Rev. D,09/06/12
9 of 26

- 3.5.9 PRESS the spring-loaded top pivot downward.
- 3.5.10 Refer to Figure 9, and TILT the SO panel upward and forward until the spring-loaded top pivot engages with the pre-drilled hole in the fixed rail.
- 3.5.11 Refer to Figure 9, and using the screw provided, FASTEN the SO panel to the SO pivot.
- 3.5.12 Refer to Figure 6, and TIGHTEN the No. 10-24 setscrew securing bottom pivot to pivot plate.
- 3.5.13 POSITION the SO door in the fully closed position.
- 3.5.14 If necessary, ALIGN SO panels vertically as follows:
 - a. LOOSEN screws adjacent to top pivot in fixed rail.
 - b. ALIGN SO panel and ENSURE that panel is level and plumb.
 - c. TIGHTEN screws adjacent to top pivot in fixed rail.
- 3.5.15 TIGHTEN screws securing the pivot bracket to the pivot plate, and ENSURE that the pivot bracket will not obstruct the SO panel as it swings open.
- 3.5.16 ENGAGE flush bolt.

3.6 Installing the SX Door Panel

NOTE

If installing Privacy Glass, reference to Stanley document number 204085.

- 3.6.1 INSTALL glass into the SX panel.
- 3.6.2 INSTALL one overlap seal on the face of the SX pivot stile and two on the SX lead stile.
- 3.6.3 **If smoke and draft kit option is required**, then refer to Figure 10 and INSTALL the SX panel hanger seals.

Figure 10. Installing the SX Panel Hanger Seal (Smoke and Draft Kit Option)

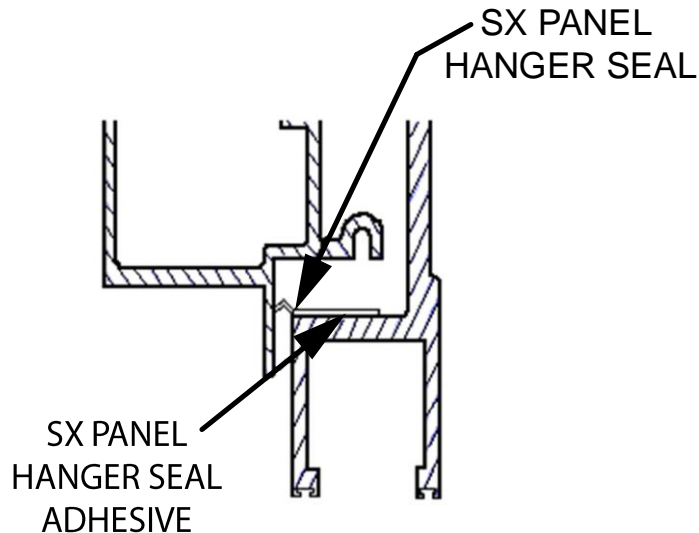

204072
Rev. D,09/06/12
10 of 26

NOTE

If the seal is not oriented correctly, a stiff wire or long thin screwdriver can be inserted between the hanger and header lip and slid along the entire length of the panel. This will cause the hanger seal lip to rest in the proper orientation.

- a. Using Windex or isopropyl alcohol, CLEAN the following:
 - 1) The flat hanger surface below the load wheels where the hanger seal will be attached AND the hanger seal.
- b. APPLY the hanger seal to the hanger. ENSURE the following:
 - 1) The formed leg extends past the hanger.
 - 2) The flat portion of the hanger seal is aligned with the edge of the hanger.
 - 3) The hanger seal protrudes approximately 1/4" past the hanger edge. (This will ensure that the hanger edge will properly seal against the header lip.)
 - 4) TRIM the seal so that it is flush with each end of the hanger.

3.6.4 Refer to Figure 11, and INSTALL the SX guide assembly as follows:

Figure 11. Installing the SX Guide Assembly

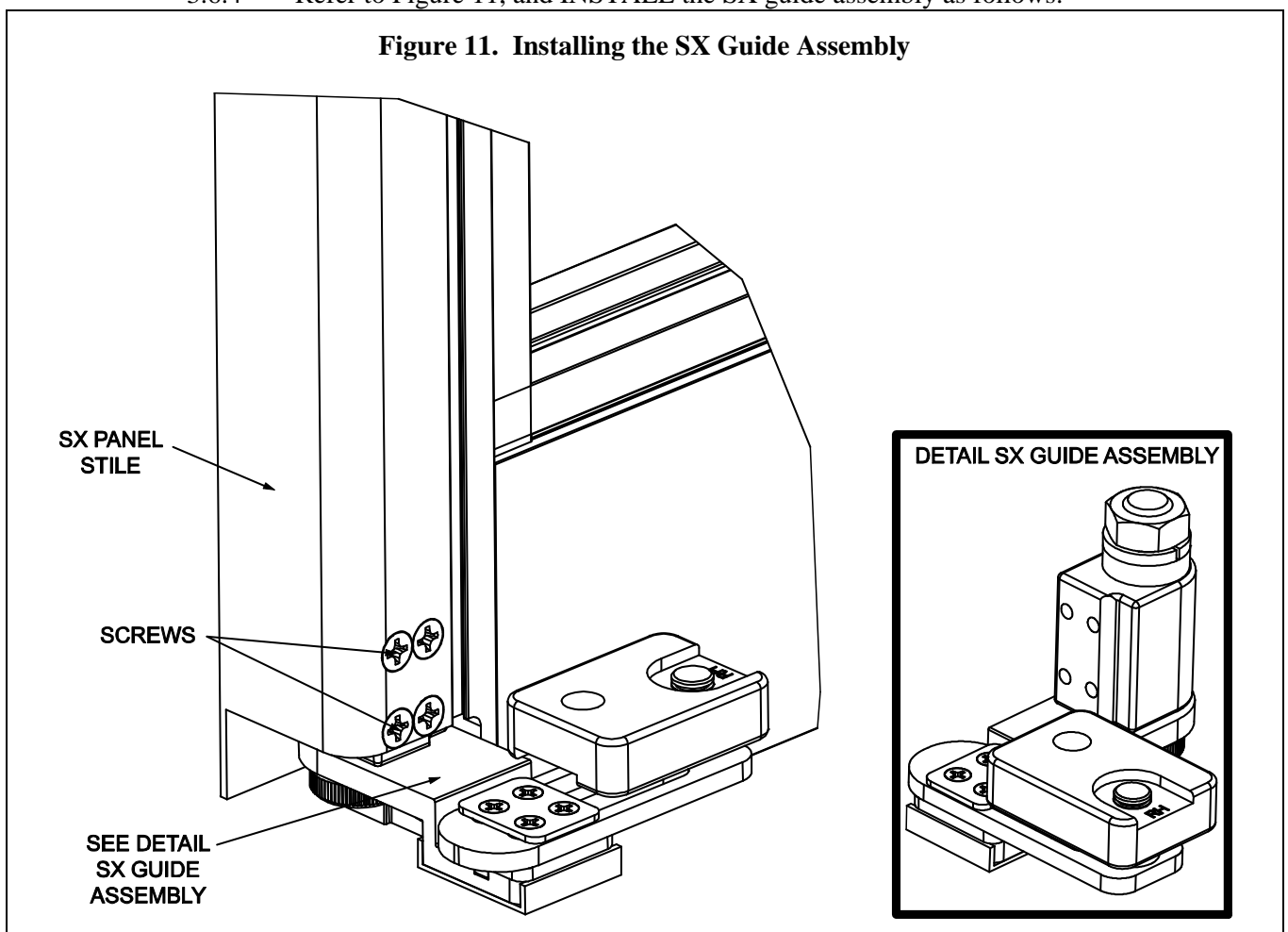

- a. INSERT the SX guide assembly into the bottom of the SX panel stile.
- b. Using the four screws provided, FASTEN the SX guide assembly to the panel stile.

- 3.6.5 Refer to Figure 12, and using the hex screw provided, FASTEN the SX pivot block to the bottom rail.

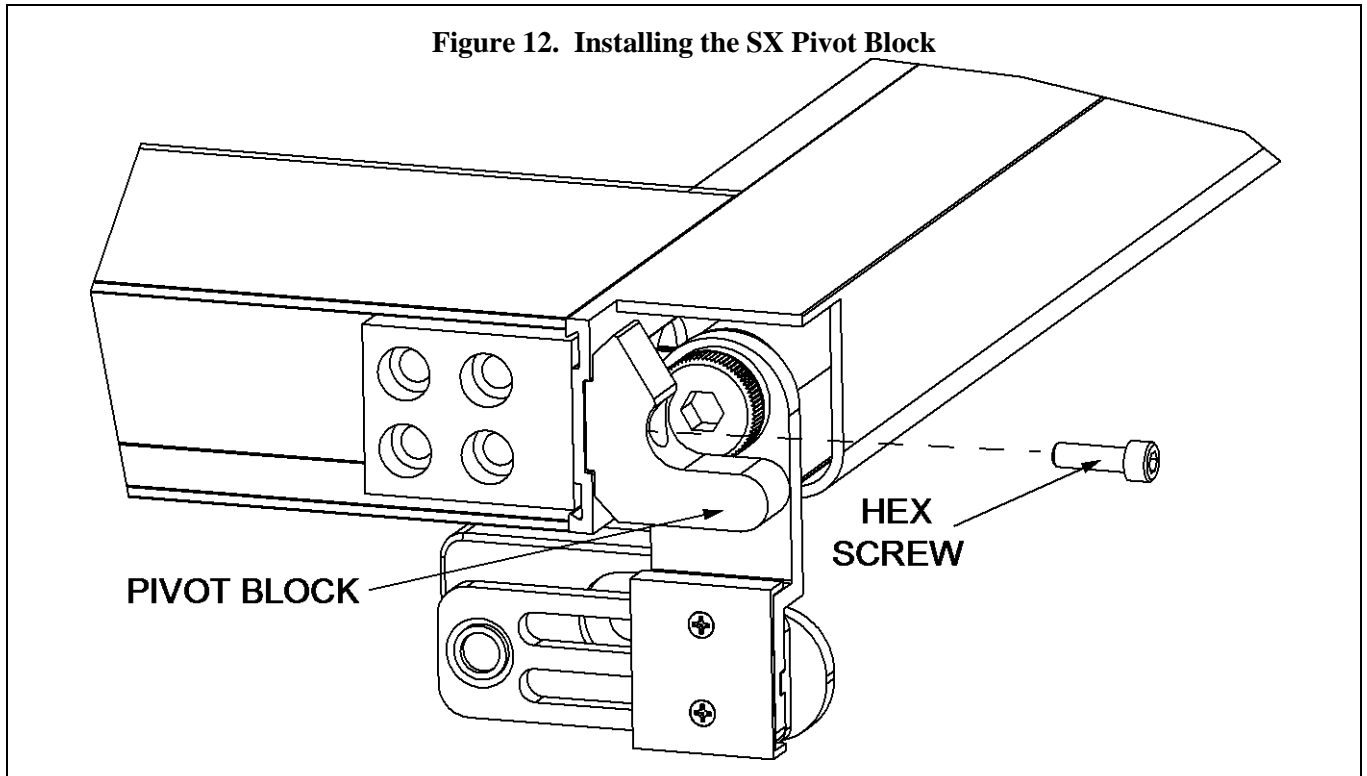

- 3.6.6 OPEN header cover. Refer to Figure 13, and LOOSEN the nuts securing the load wheels and anti-riser wheels to the hanger.
- 3.6.7 Using an Allen wrench, SET the load wheels to the midrange of travel position in the hanger. In this position, the top of the load wheel is $1/16$ " below the top of the hanger.
- 3.6.8 SET the anti-riser wheels so that the top of each wheel is flush with the top of the hanger.

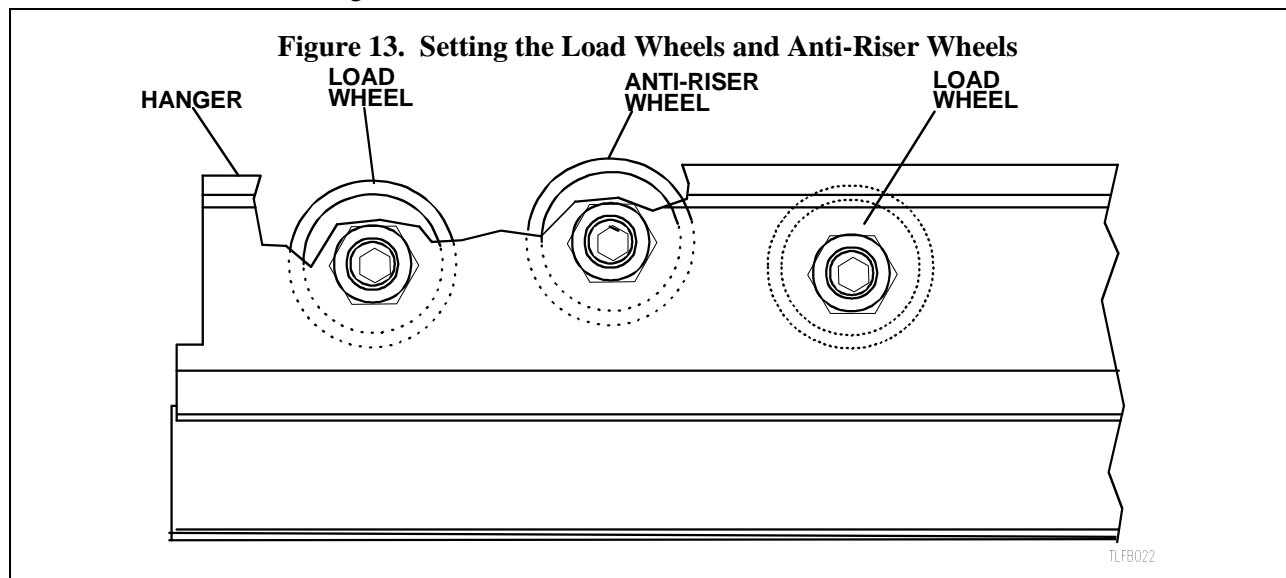

3.6.9 TIGHTEN the nuts securing the load wheels and anti-riser wheels to the hanger.

WARNING

Whenever the door anti-riser wheels are not set, there is a possibility that the panel could fall off the hanger track. Use extreme caution when handling the door panels.

3.6.10 ENSURE glass stops and lock cylinder hole are correctly positioned with respect to the door application (lock facing interior of building).

3.6.11 Refer to Figure 14; INSERT the SX panel bottom guide assembly into the SO panel as follows:

- a. Carefully LIFT the SX panel and POSITION the panel so that it is parallel to the header.
- b. MOVE the SX panel so that it is resting on the pivot plate.
- c. Mount the SX panel on the track with the door adjusted all the way to the bottom.
- d. INSERT the SX panel bottom guide assembly into the bottom of the SO panel.
- e. Raise the panel and adjust the load wheels to nominal.

Figure 14. Installing the SX Panel

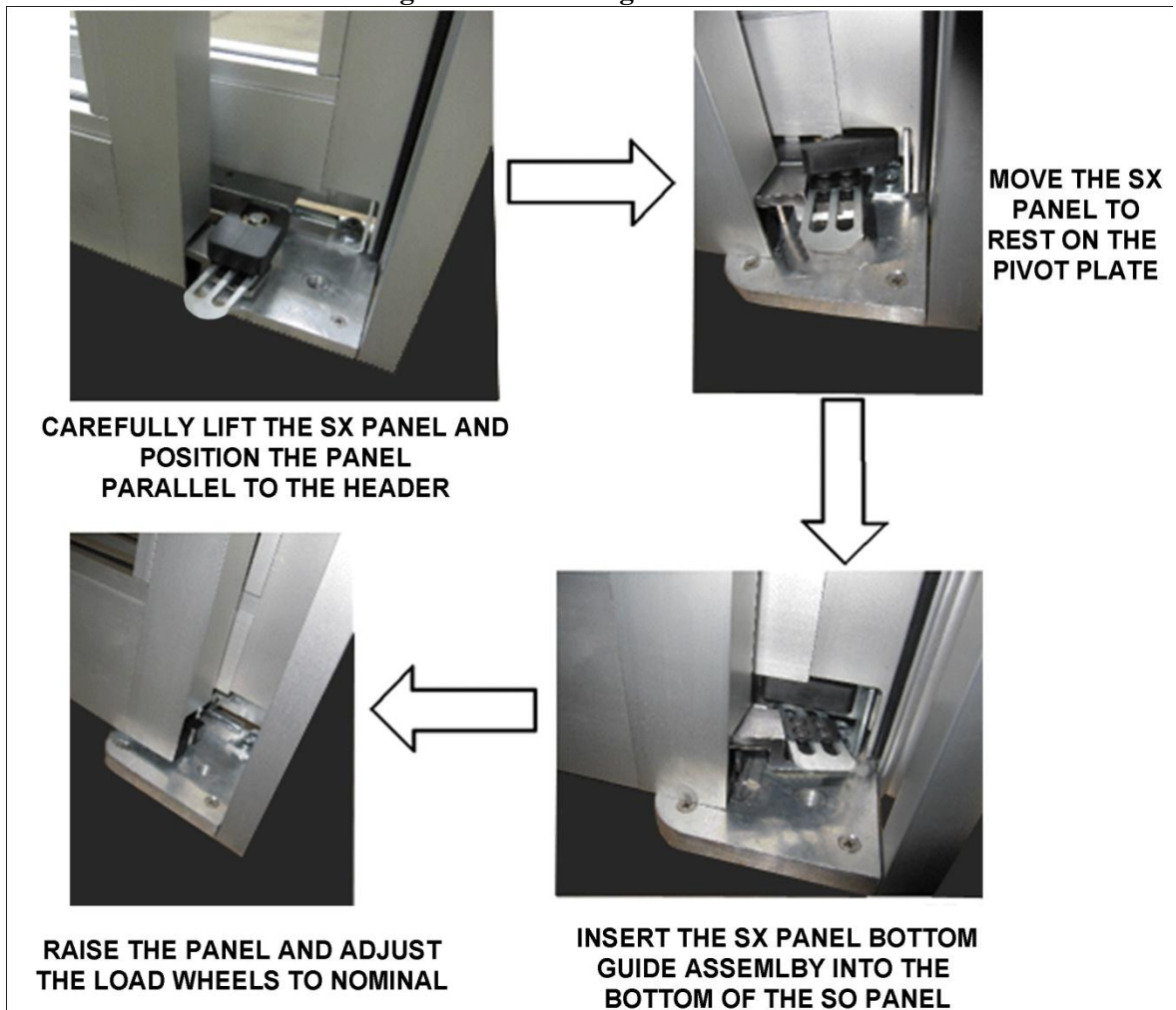

- f. Refer to Figure 15, and **THREAD** the bottom SX pivot into the pivot plate such that the top of the stepped pivot flat is $\frac{1}{4}$ " above the top of the pivot plate.
- g. **ALIGN** flats on the SX pivot so they are parallel to the SX panel bottom rail.
- h. **TIGHTEN** nut at bottom of SX pivot.
- i. **SLIDE** SX panel over the SX pivot.

Figure 15. Installing the SX Pivot

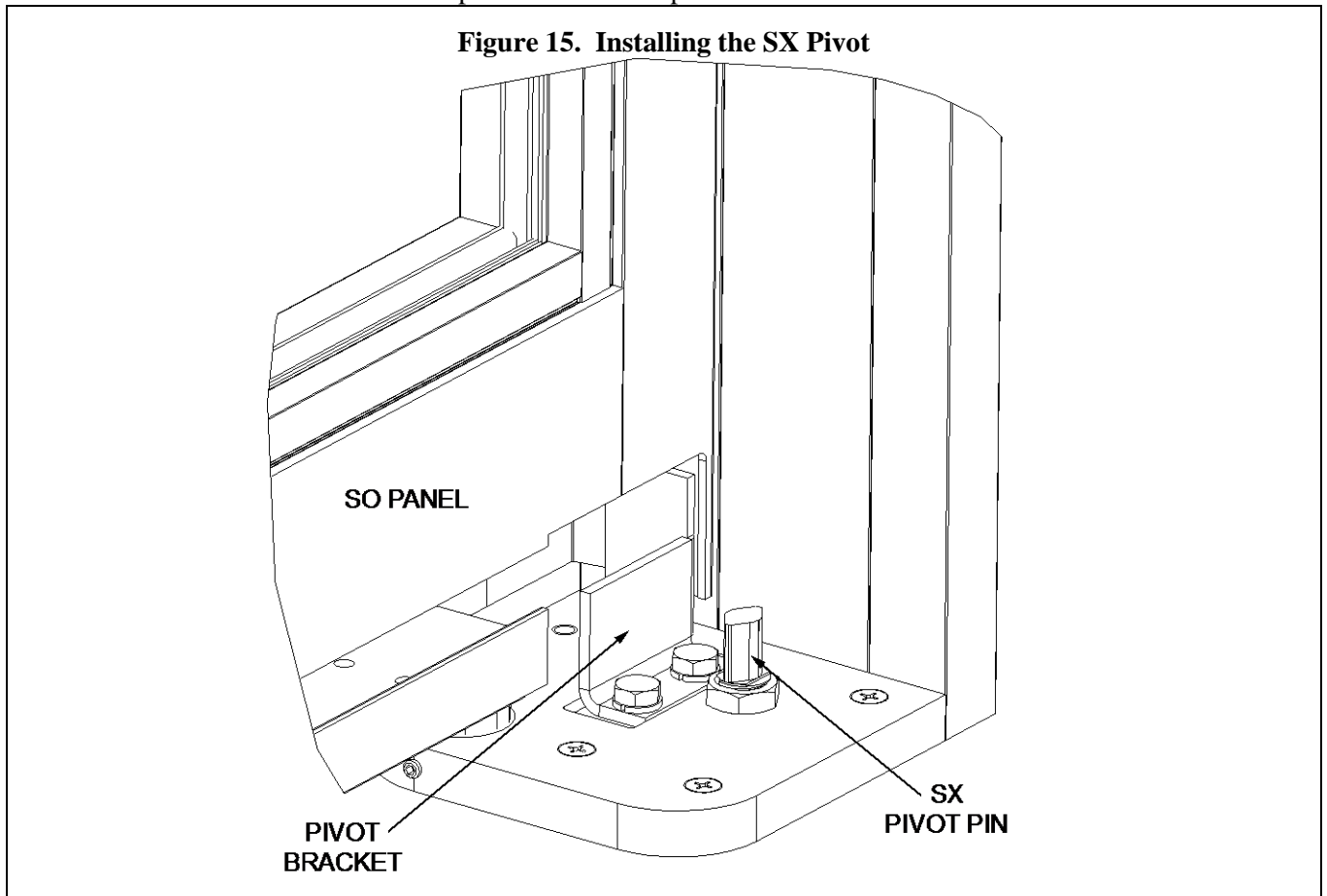

- 3.6.12 **SET** the hanger anti-riser wheels so that there is a $\frac{1}{64}$ " to $\frac{1}{32}$ " gap between the top of each wheel and the track.
- 3.6.13 **IF smoke and draft kit option is installed**, slide the SX panel back and forth, and **DETERMINE** if there is excessive resistance or noise resulting from the installation of the hanger seal.
 - a. If excessive resistance or noise is observed, **PERFORM** the following:
 - 1) **Visually INSPECT** the orientation of the seal by looking from the end of the seal.
 - 2) **ENSURE** that the seal acts like a spring and folds so that the tip is pointing down as shown in Figure 10.
 - 3) If necessary, **ADJUST** the seal so that it is oriented properly.
 - 4) If any load wheel adjustment was needed to remove/install the SX-Panel, **ENSURE** that the SX panel is properly aligned and the anti-riser wheels are properly adjusted.

204072
Rev. D,09/06/12
14 of 26

3.6.14 **IF smoke and draft kit option is required, INSTALL** the four SX and SO panel top rail seals as shown in Figure 16.

a. **ENSURE** the following:

- 1) The seals extend the full width of the rails, and are trimmed flush.
- 2) **INSTALL** the plastic end caps and foam end cap seals after installation.

Figure 16. Installing the SX and SO Top Rail Seals (Smoke and Draft Option)

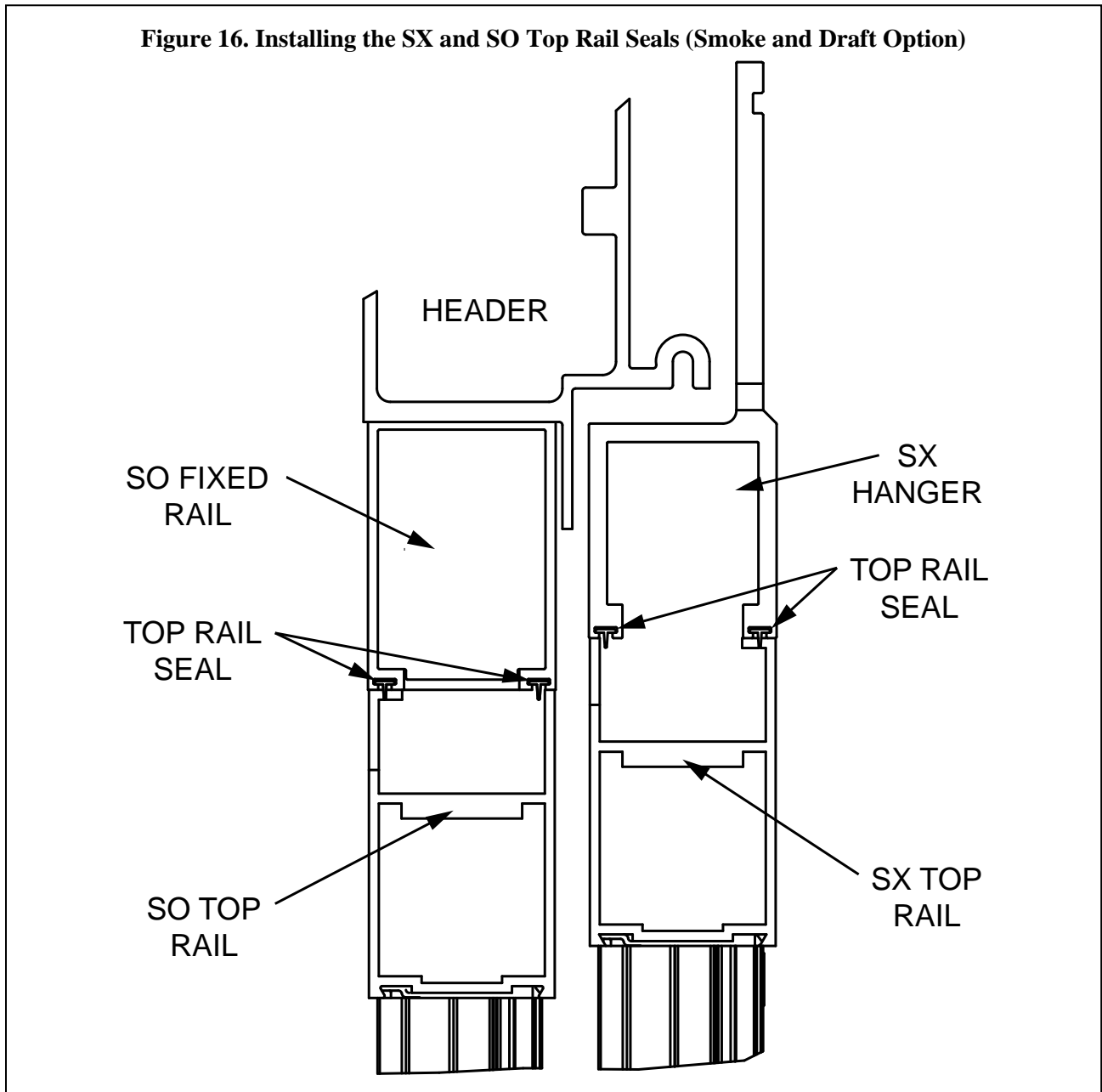

3.7 Performing Final Adjustments

3.7.1 Refer to Figure 17 and **ADJUST** the SX and SO bottom pivots

204072
Rev. D,09/06/12
15 of 26

a. ENSURE the following:

- 1) Vertical leading edges of the lead panels overlap squarely and evenly along entire height of panels.
- 2) Tops and bottoms of panels are horizontally even.
- 3) The gap between the panels and jambs is even along the entire height of the panels.

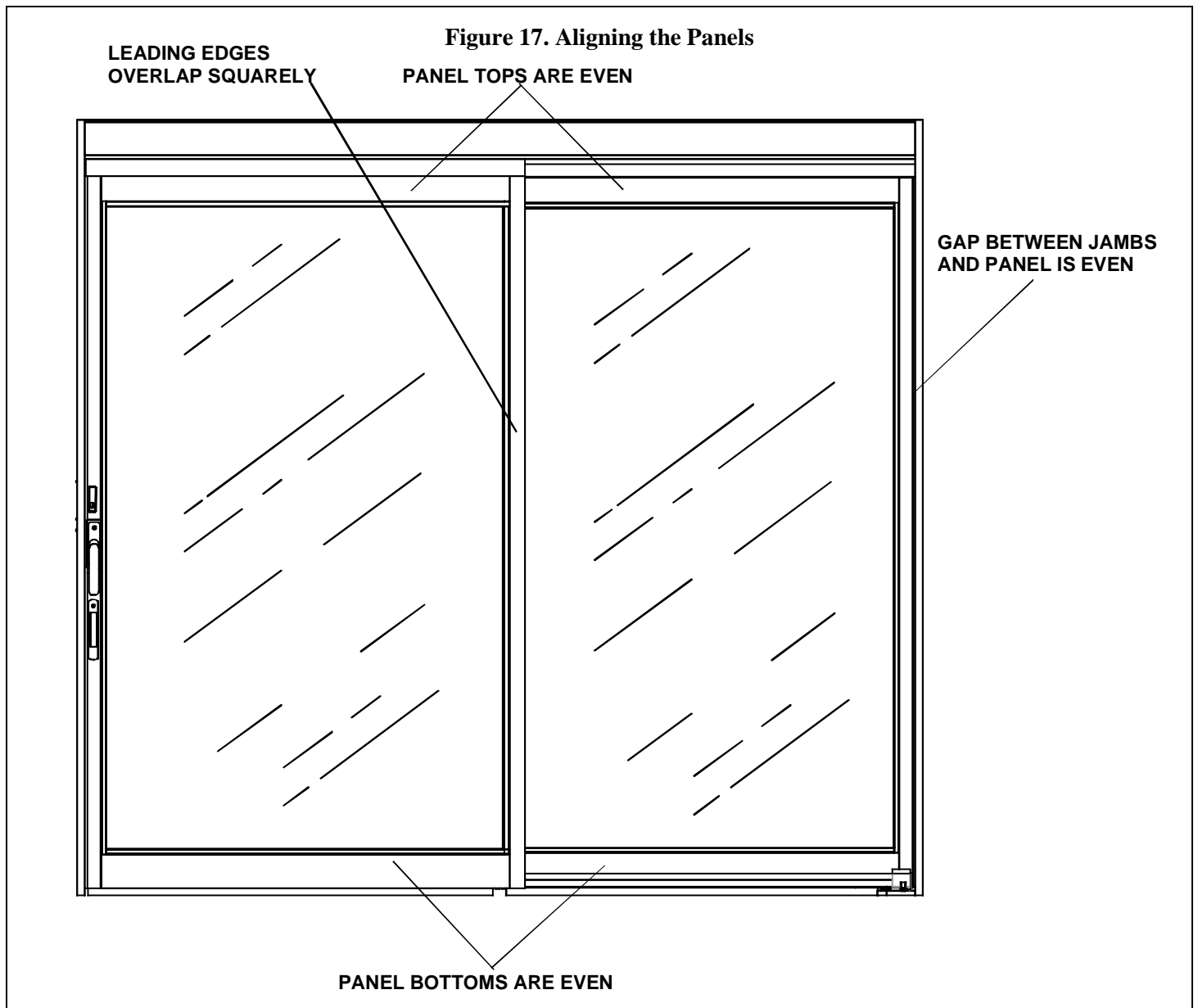

3.7.2 ADJUST the bottom sweeps as follows:

204072
Rev. D,09/06/12
16 of 26

NOTE

After installation of the kit, the dual-brush bottom sweeps must be adjusted to seal against the floor and track as applicable.

- a. Refer to Figure 18, and INSERT a pry bar or equivalent through the bottom-sweep brush and hook onto the “L” at the bottom of the sweep extrusion.

Figure 18. Adjusting the Dual-Brush Bottom Sweep

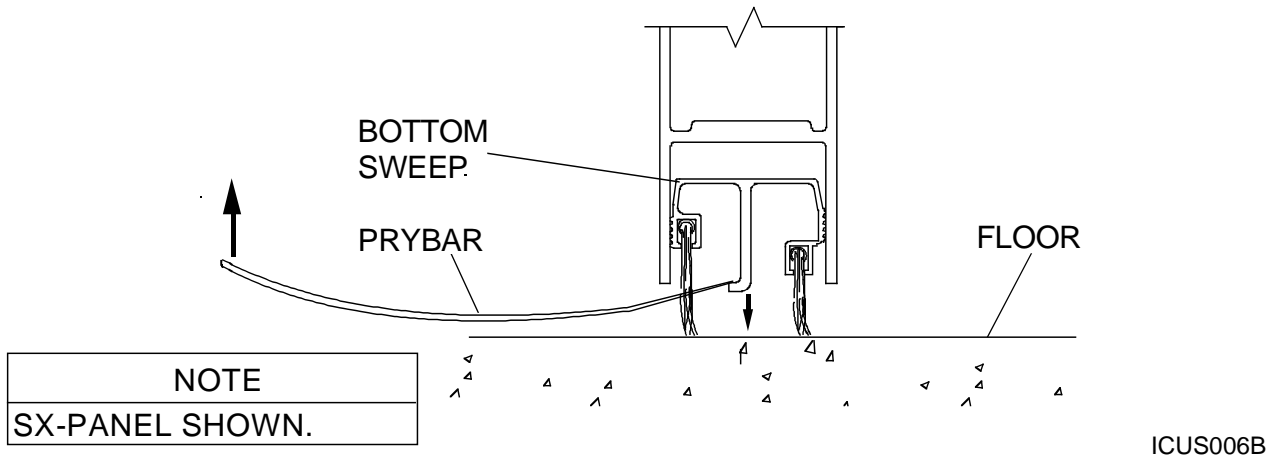

- b. PRY the seal assembly downwards until it just touches the floor/track.
- c. TEST the operation of the door system, and ADJUST the sweep as necessary to achieve the best compromise between ease of door operation and sealing of the panels.
- d. CYCLE SX panel several times and ENSURE the following:
 - 1) Door self-closer brings door to full close. (If self-closure option is installed.)
 - 2) Door latches properly. (If positive latch option is installed.)
 - 3) Door locks engages properly. (If 1-point lock option is installed.)
- e. ENSURE latch bolt secures the SO panel.

3.7.3 ADJUST the emergency egress breakout detents as follows:

NOTE

1. Breakout detents are factory set to average requirements. If more or less breakout force is required to open door, the breakout detents can be adjusted.
2. During door installation, the breakout detents are set tight to prevent the door from swinging out and being damaged. During door tune-in, the breakout detents must be readjusted.
 - a. OPEN SX and SO panels to the full open position.
 - b. BREAK OUT the SX and SO panels.

- c. Refer To Figure 19, and LOOSEN two fasteners in bottom of detent block.

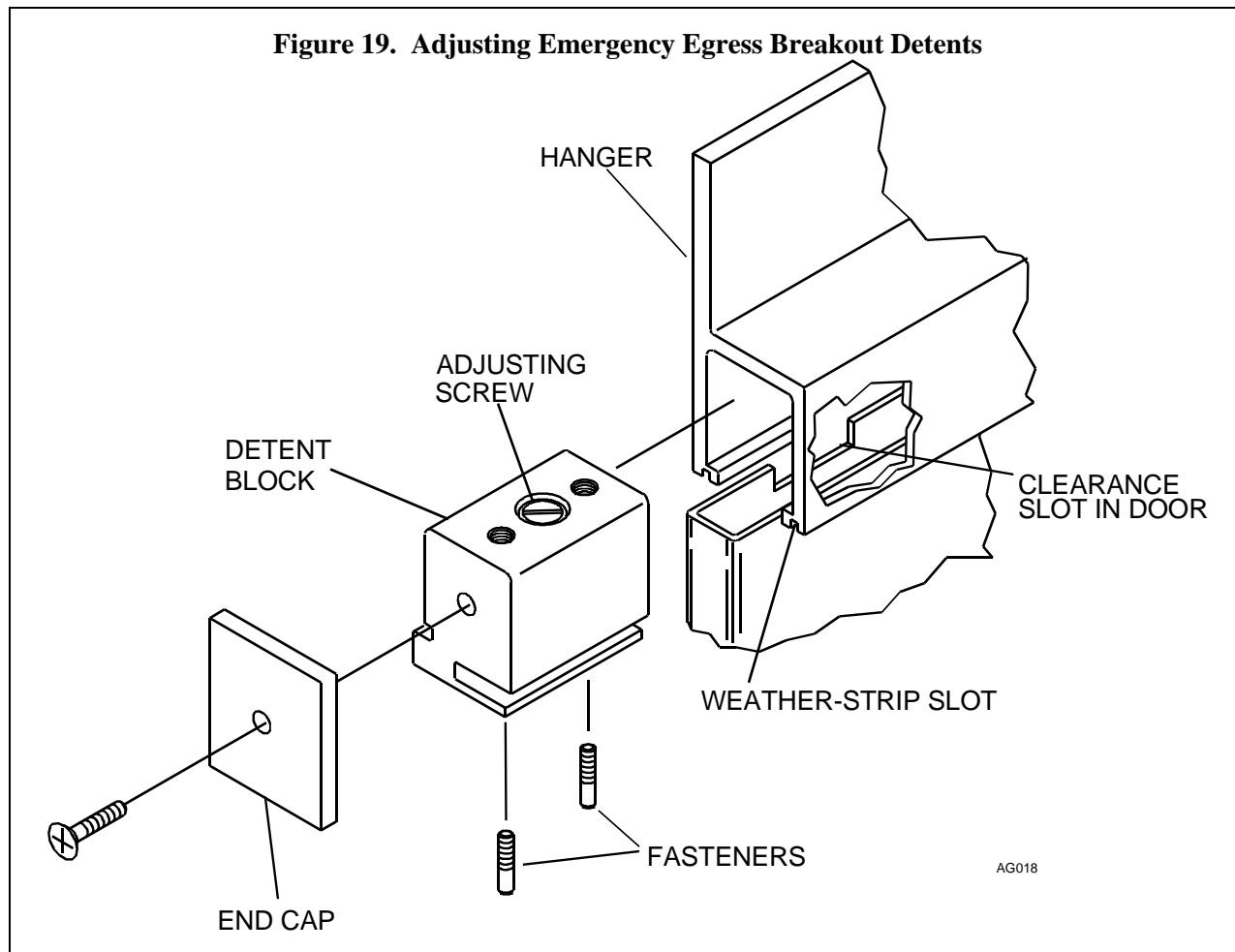

- d. REMOVE end cap and detent block from hanger.

NOTE

Turning adjusting screw clockwise increases the force required to break out door. Turning adjusting screw counterclockwise decreases the force required to break out door.

- e. TURN adjusting screw in top of detent block as necessary to ensure door will be tight.
- f. SLIDE detent block and end cap into hanger, and ENSURE detent block is aligned with clearance slot in door.
- g. TIGHTEN two fasteners in bottom of detent block.
- h. With "TOP" indication facing upward, POSITION end cap over hanger.
- i. TIGHTEN fastener securing end cap to detent block.

3.8 Installing the Latch Assembly

3.8.1 Refer to Figure 20, and INSTALL the latch assembly.

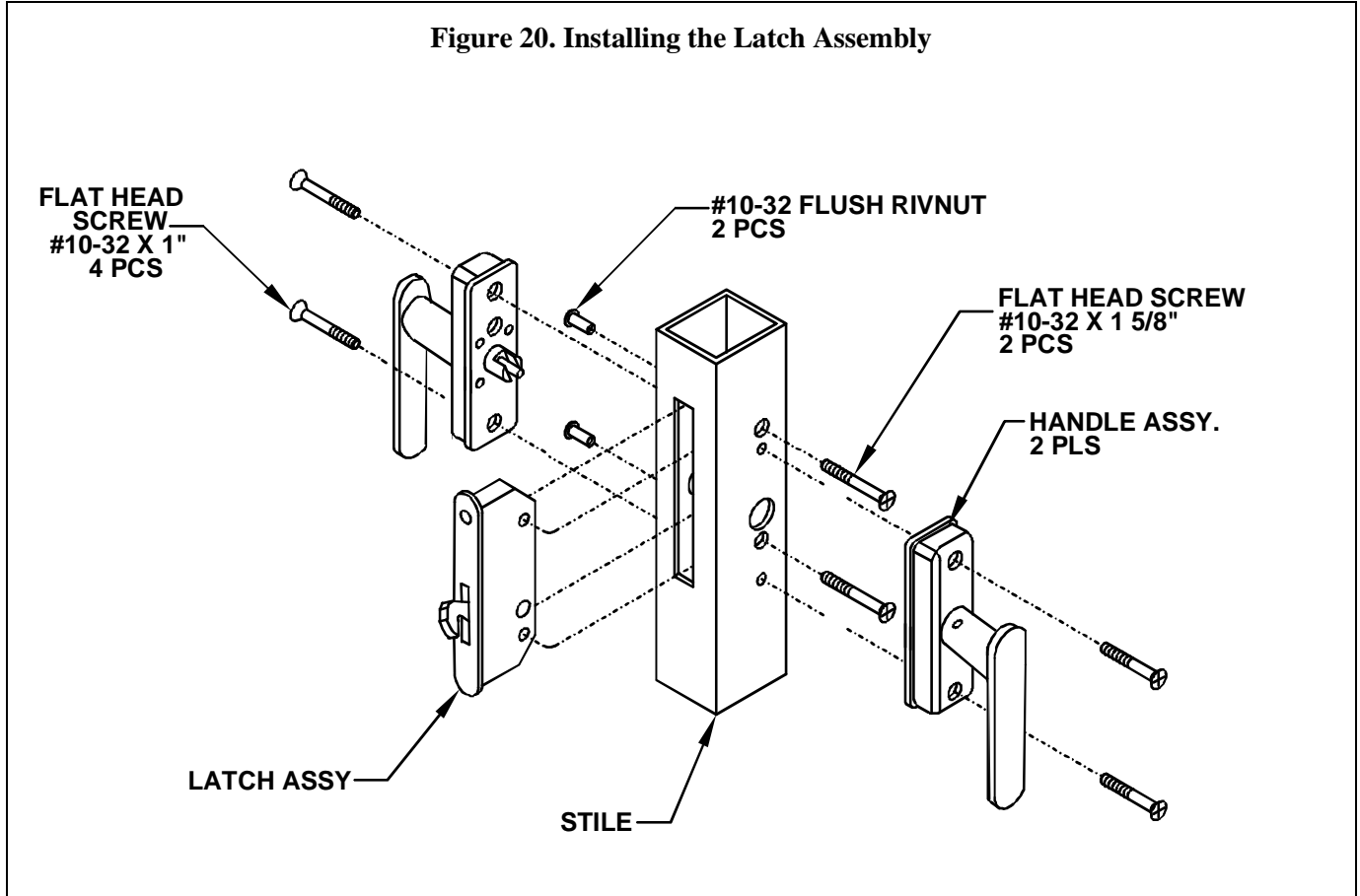

3.9 Installing Self Closure/Damper Kit (Optional)

3.9.1 Refer to Figure 21 for Right-Hand door packages and Figure 22 for Left-Hand Open door packages.

- a. Remove the four screws from bottom and top of closure spring unit
- b. ATTACH support plate to header using two #8-18 self-tapping screws as shown.
- c. FASTEN spring unit to support plate using the two screws from 3.9.1.
- d. LOCATE threaded hole in header and ATTACH pulley to header, using the provided screw.
- e. For Right Hand door packages, extend retractable closure wire from spring unit, and wrap around the pulley, then back to the BOTTOM spring unit screw.
- f. For Left Hand door packages, extend retractable closure wire from spring unit, and wrap around the pulley, then back to the TOP spring unit screw.

NOTE

Adjust closure wire tension as necessary by turning screw on face of spring unit using flathead screwdriver.

Figure 21. Installing the Self-Closure/Damper Kit (Optional) for Right Hand Door Packages

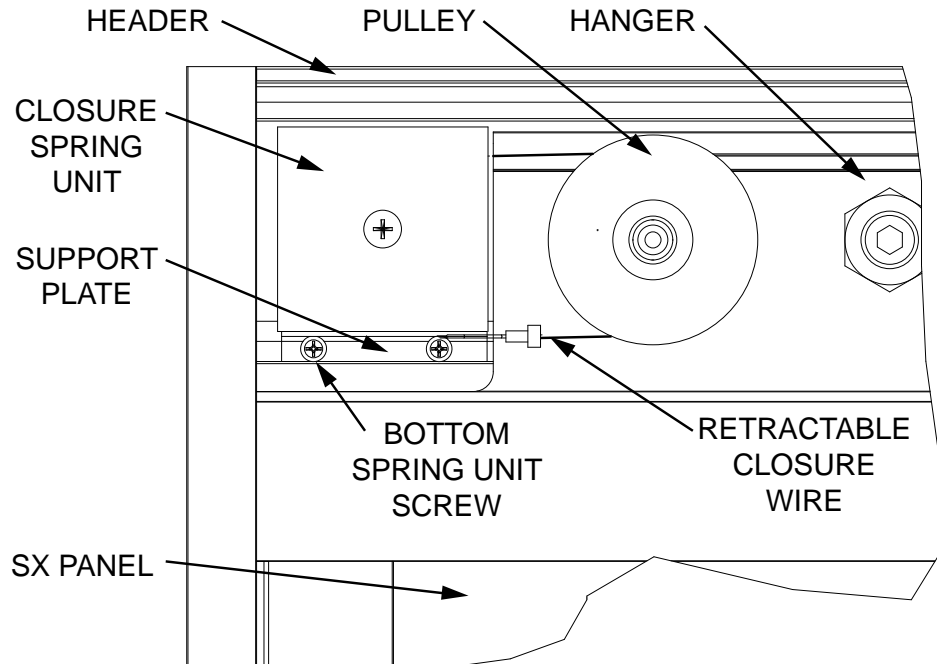
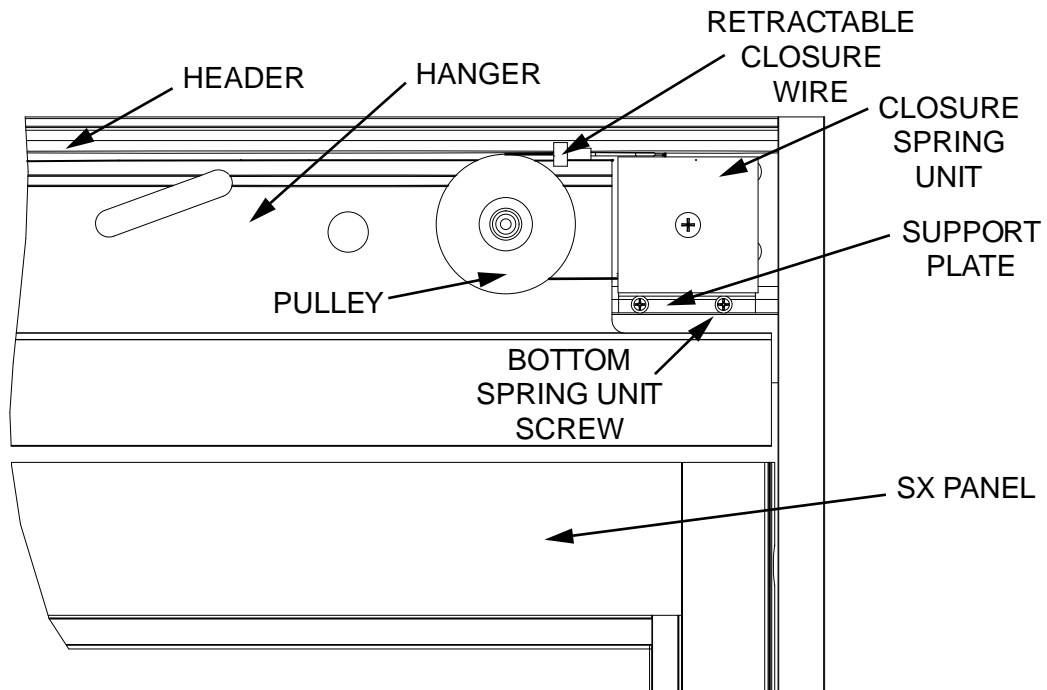
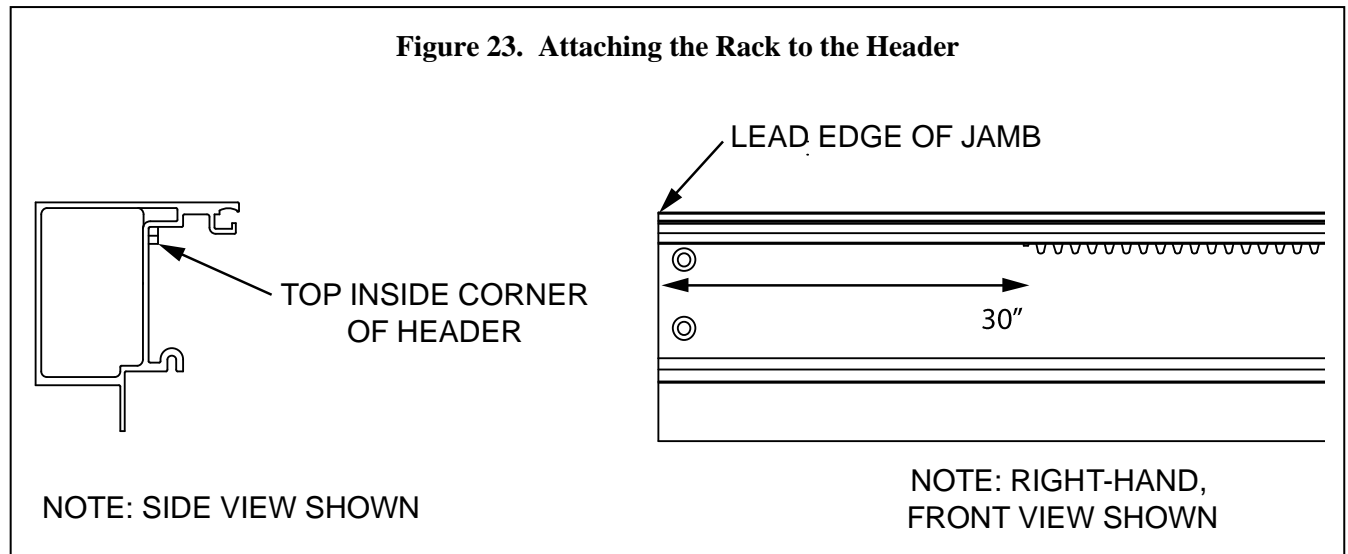

Figure 22. Installing the Self-Closure/Damper Kit (Optional) for Left Hand Door Packages



- 3.9.2 Refer to Figure 23, FASTEN rack to header using thin, double-sided tape 30" from the lead edge of the jamb.
- ENSURE it is in line with the top inside corner of the header extrusion.
 - ENSURE the horizontal position allows from the gear to make contact, slow down, and then disengage.

Figure 23. Attaching the Rack to the Header



- 3.9.3 Refer to Figure 24. ATTACH the damper to the hanger, using two #8 screws. Adjust up or down as necessary to ENSURE gear teeth catch the rack.

Figure 24. Attaching the Damper to the Hanger

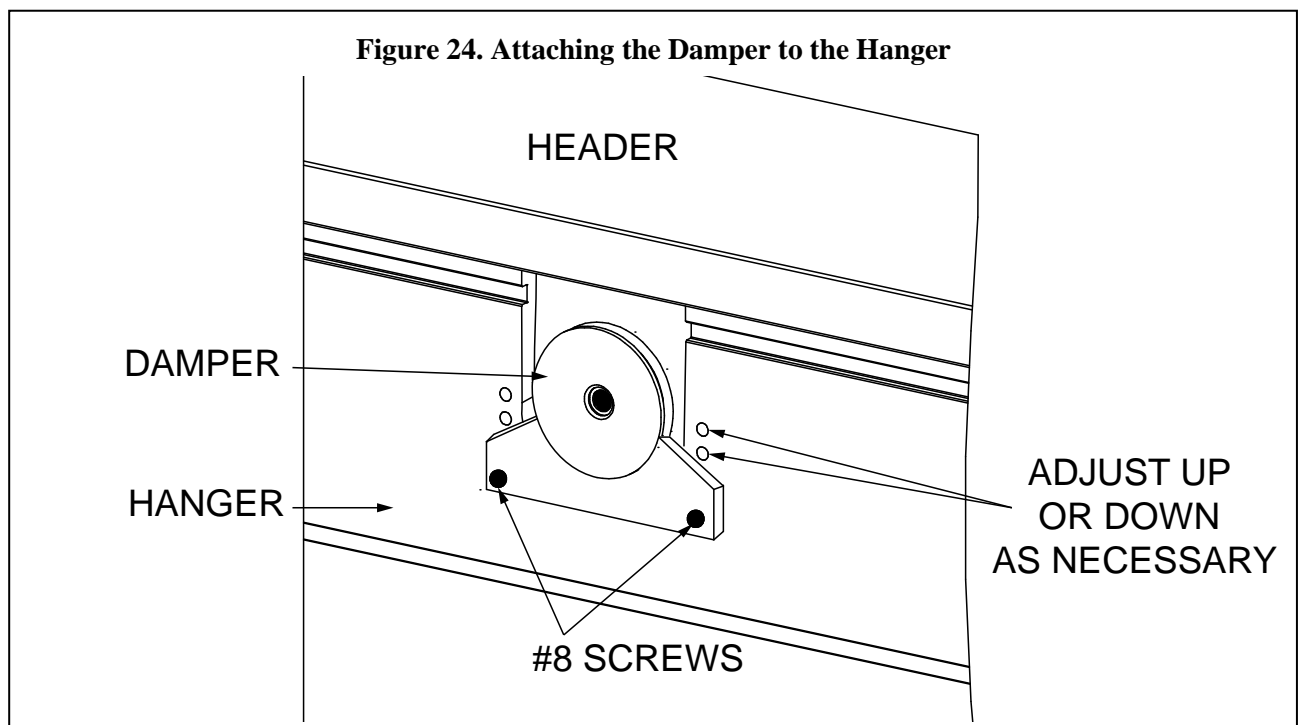

- 3.9.4 The clutch can be reversed by taking the clip out and reversing the white wheel.

204072
Rev. D,09/06/12
21 of 26

3.10 Performing the Closeout Procedure

- 3.10.1 ENSURE glass is not cracked or broken.
- 3.10.2 ENSURE glass and metal surfaces are clean.
- 3.10.3 ENSURE door installation area is clean and free of debris.

CAUTION

1. Caulk joints of ¼ inch are typical. If caulk gap exceeds ½ inch, the Installation Coordinator must be consulted to determine corrective actions.
2. The header cover joint must *never* be caulked.

3.10.4 IF required, CAULK the following as specified in door specification, work order, or construction documents:

- a. Top of header, sides of jambs

3.10.5 COMPLETE Work Order and REPORT your actions to Building Superintendent.

3.11 Proper Glass Blocking of Door

- 3.11.1 Partially swing or slide door open and slide a wedge under the lead stile
- 3.11.2 Install outer glass stops with vinyl inserts
- 3.11.3 Position glazing shims

NOTE

For door panels with an intermediate rail, glaze the LOWER section of door FIRST and follow steps 3.11.3 – 3.11.6. After the lower section has been glazed follow the same basic procedures for the upper section.

- a. For door panels WITHOUT intermediate rails, refer to Figure 25a and position shims at points #1, #2, & #3
- b. For door panels WITH intermediate rails, refer Figure 25b and position shims in the lower section at points #1, #2, & #3

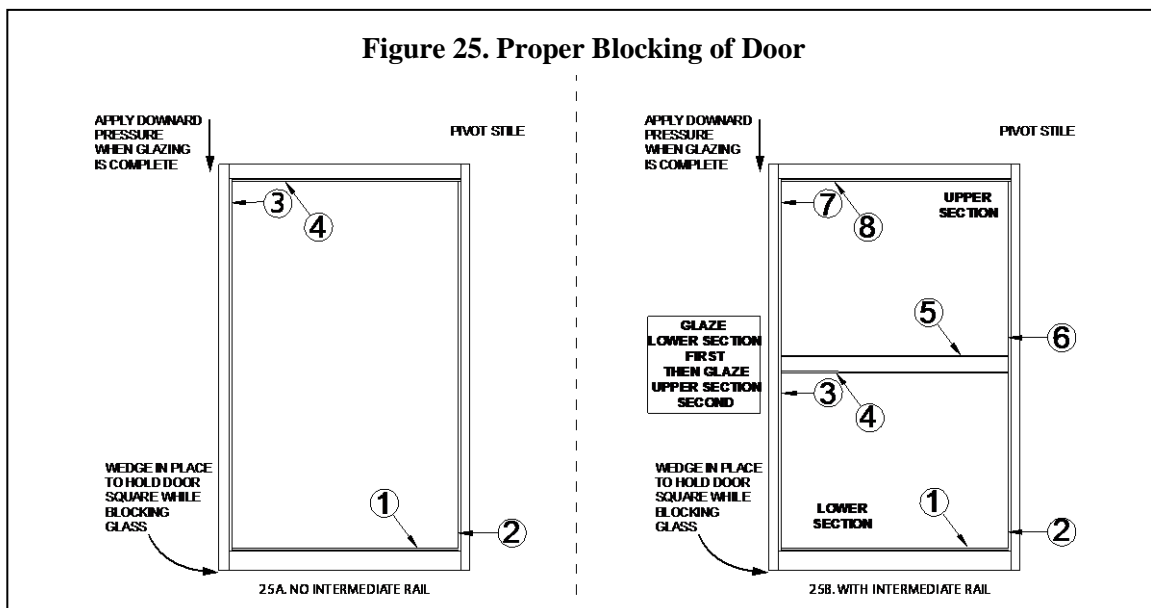

204072
Rev. D,09/06/12
22 of 26

3.11.4 Insert glass panel

- a. Insert glass pane with shims in place
- b. ENSURE margin or gap between the glass edge and aluminum door frame is equal distance at the top, bottom, and two sides
- c. IF margin is unequal, add shims to reference points #1, #2, #3 as shown in Figure 25a/25b to obtain an equal margin

3.11.5 Adjust glazing

- a. Refer to Figure 25a/25b reference point #4 and determine thickness of shim
- b. Drive the wedge further under lead door stile and insert shim

REMINDER:

For door panels WITH intermediate rail: REPEAT Sections 3.11.3 – 3.11.6 for the upper section at reference points #5, #6, #7, #8.

3.11.6 Install interior glass stops

- a. Install interior glass stops with vinyl inserts
- b. Remove wedge from under lead door stile
- c. ENSURE door is square in closed position

Attachment 1
Documents, Definitions, Tools, Equipment, Materials, and Consumables
(Sheet 1 of 1)

Documents

- Manufacturer's instructions for latch and lock installation.

Definitions

- None

Tools and Equipment (including, but not limited to)

- Caulking gun
- Combination square
- Concrete drill bits
- Electric drill
- Metal drill bit set
- Saw horses (with protected working surface)
- Screwdriver kit
- Stanley bottom pivot adjusting wrench
- Tape measure
- Stanley pivot adjusting wrench

Materials (including, but not limited to)

- Concrete expansion shields
- Glass panels
- ICU Smoke and Draft Control Option Kit and panel Seals including the following:
- Lag bolts

Consumables (including, but not limited to)

- Clean rags
- Glass cleaner or Isopropyl alcohol
- Silicone caulk

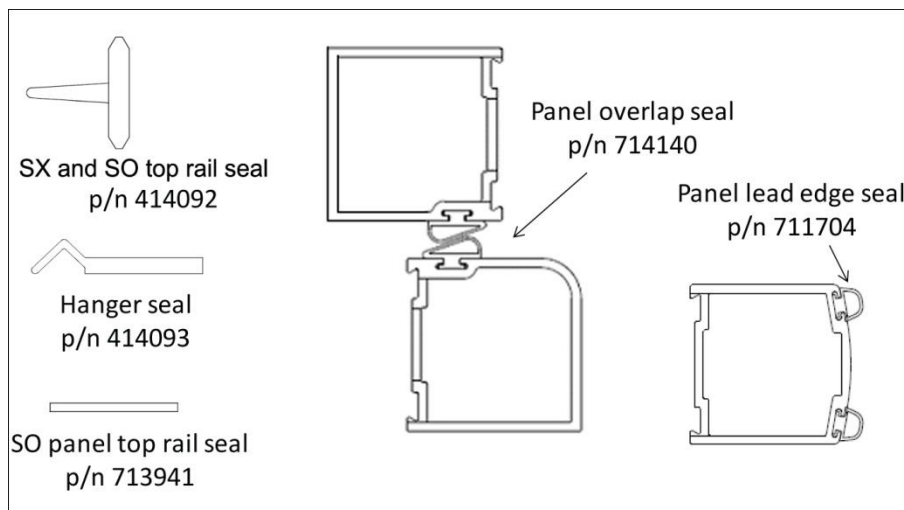

204072
Rev. D,09/06/12
24 of 26

Attachment 2
Replacement Parts
(Sheet 1 of 2)

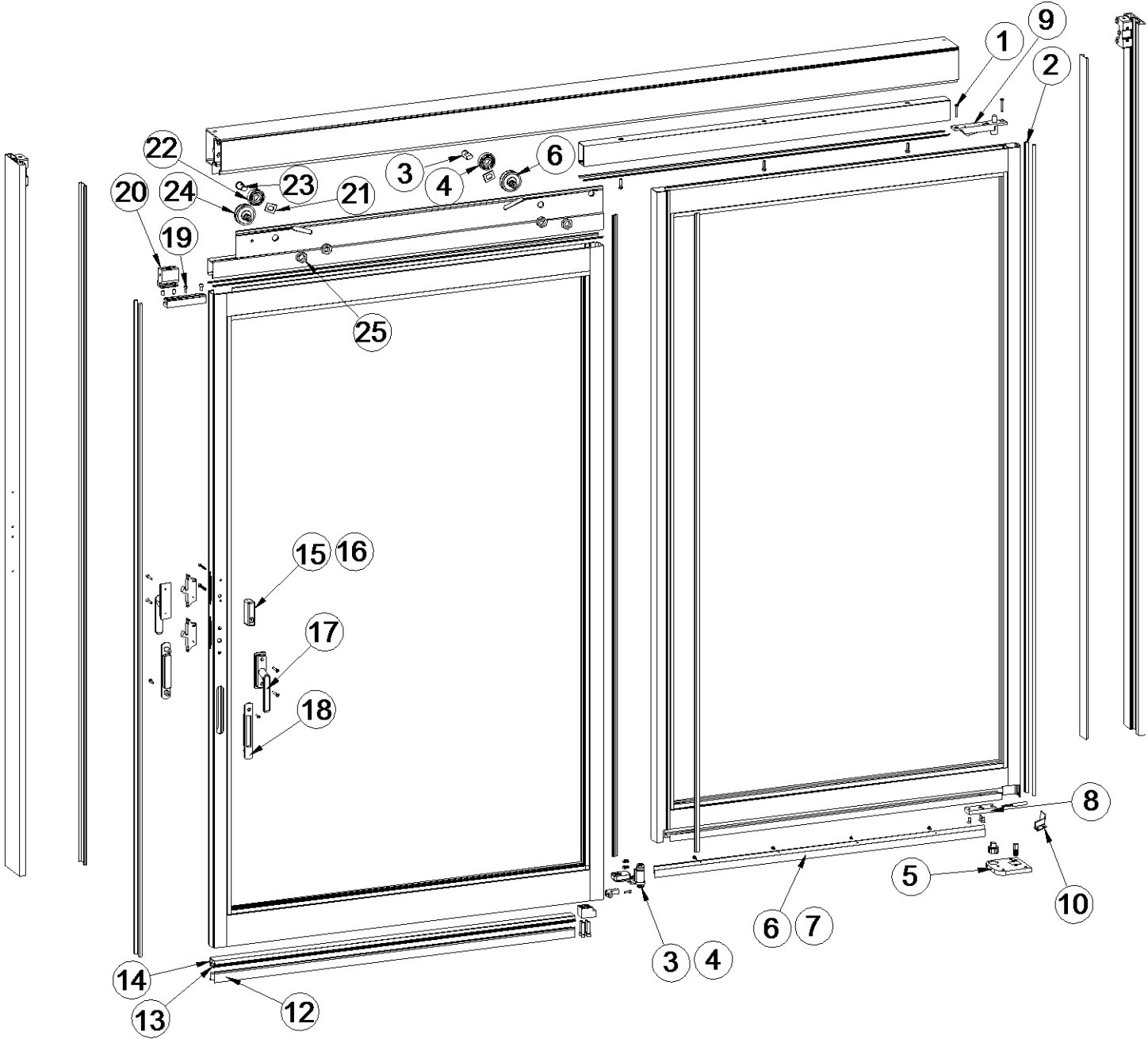

Attachment 2
Replacement Parts
(Sheet 2 of 2)

Item	Part No.	Description
1	314129	KIT-ICU SMOKE/DRAFT CONTROL OPTION
2	314128	KIT-WEATHERSTRIP AND SEAL
3	314127	KIT-BOTTOM GUIDE ASSY-RH
4	314126	KIT-BOTTOM GUIDE ASSY-LH
5	314125	KIT-HARDWARE-DC7200TLFBO
6	417201	GASKET-SWEEP
7	417199-12000	EXTRUSION-SWEEP HOLDER
8	410895	PIVOT-BOTTOM-DOOR PORTION
9	410545	PIVOT-TOP
10	417225-1	BLOCK, PIVOT PLATE-LH
	417225-2	BLOCK, PIVOT PLATE-RH
12	713241-13200	THERM-L-BRUSH-LONG PILE
13	710739-12000	BRUSH-BOTTOM-SWEEP
14	413769-18000	HOLDER-SWEEP
15	714481-1	THUMB TURN-NARROW-CLR
	714481-2	THUMB TURN-NARROW-BLK
16	714447-1	KIT-ICU DEADBOLT LOCK-NARROW-CLR
	714447-2	KIT-ICU DEADBOLT LOCK-NARROW-BLK
17	714446-1	KIT-ICU LATCH-NARROW-CLR
	714446-2	KIT-ICU LATCH-NARROW-BLK
18	515769	PULL-DOOR-REC-7000-BLACK
19	516699-3	DETENT,NARROW STD(RH) & MED W/A CTRL(RH)
20	411622	DETENT ASSY-SX-HANGER PORTION - CLR
	431622	DETENT ASSY-HANGER PORTION - BRZ
21	711627	PLATE-BACK UP
22	412405	ROLLER ANTI RISER
23	411450	STUD-ANTI-RISER
24	380257499	NUT-HEX-JAM-3/4-10
25	411499	WHEEL ASSY-LOAD
26	417198	END CAP-SO FIXED RAIL
27	714493	SCREW-#8-18 X 5/8"-FHUC-SST
Not Shown	714488	CLOSURE AND DAMPER KIT OPTION
Not Shown	417216	RACK FOR DAMPER OPTION

204072
Rev. D,09/06/12
26 of 26