

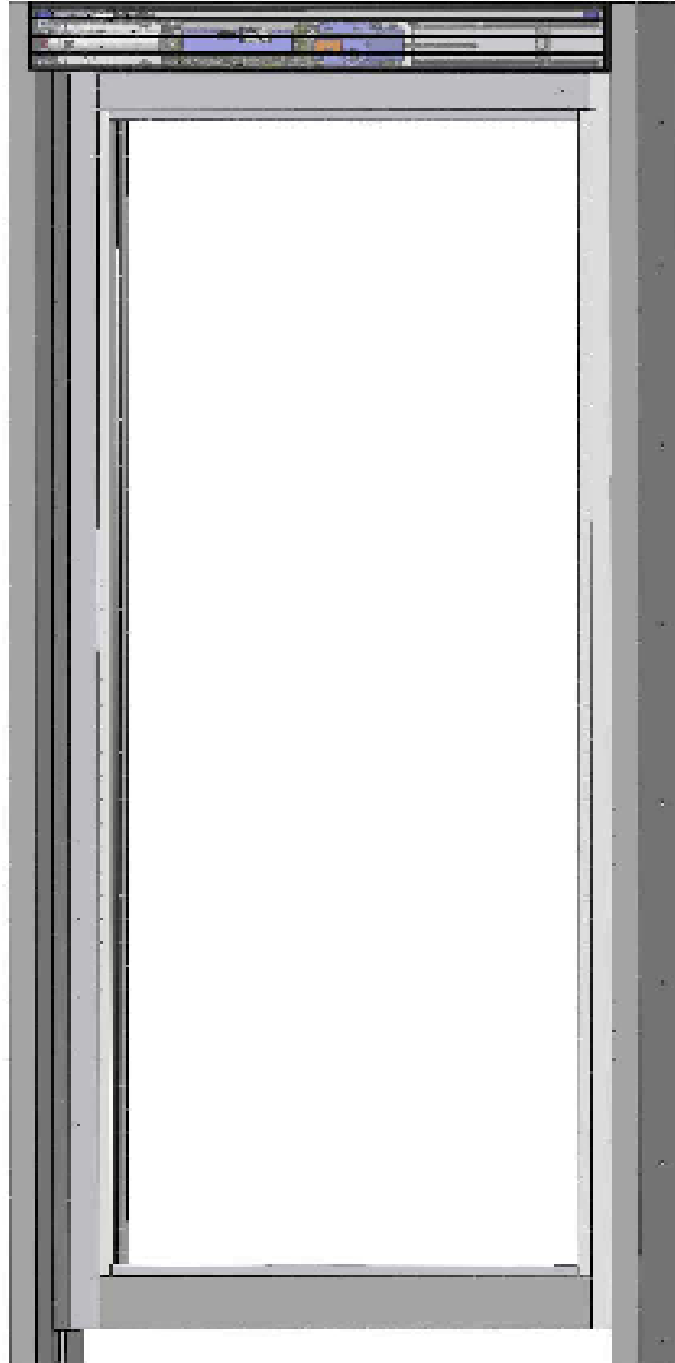

# 8600/8700 Series OHC/Butt Hung Swing Door Installation Instructions

---

---



The manufacturer's specifications for this product require the installation to be approved by an AAADM certified inspector.





# 8600/8700 Series OHC Swing Door Installation Instructions

The record-usa 8600/8700 Operator Package has been carefully designed, built, and tested to provide years of service.

The life of the operator package is directly related to how carefully the installation is accomplished and how accurately the instructions are followed. Installation of this operator package should be done by properly trained and knowledgeable installers with a knowledge of local code requirements and the requirements of ANSI A156.10 Standards for Power Operated Pedestrian Doors and A156.19 Standards for Low Energy and Power Assisted Pedestrian Doors. The authorized service / installation dealer must perform all measurements for forces, speeds, and times to insure proper and safe operation.

Verify that the door may be opened without power applied to the unit.

Verify that the force required to open the door with the power disconnected shall not be greater than 50 pounds.

Verify that the door does not close with a force greater than 40 pounds at the latch side of the closing stile, and does not close the final 10 degrees in less than 1.5 seconds.

record-usa is not responsible for improperly adjusted or maintained automatic doors or activation / safety systems and assumes no responsibility for damages caused by automatic door systems that have not been properly installed, tested, and adjusted.

## OWNER INFORMATION TO BE PROVIDED BY THE DISTRIBUTOR / INSTALLER

- \* After the installation instruct the owner on the safe operation of the door.
- \* Location and proper use of the power switches.
- \* Location of the main cutoff breaker.
- \* Necessary warnings not covered in general instructions.
- \* Owners Manual and Daily Safety Checklist.
- \* Phone number(s) for the local servicing dealer.
- \* What to do in the event that a dangerous situation should occur, and how to shut the doors down and call for service.

## READ INSTALLATION INSTRUCTIONS BEFORE INSTALLING.

The sequence of installation and adjustment is in order, however some sections will not apply. Review this instruction manual and determine those sections that do apply. Be sure all doors swing freely and clear all objects before creating an activation.

## INDEX

INTRODUCTION, OWNER INFORMATION & INDEX.....	2
HANDING ID, ELECTRICAL PREPARATION, OPERATOR VIEW.....	3
8600/8700 HEADER TO JAMB PREP / 8600 DOOR PREP.....	4
8600 OPERATOR & POWER SUPPLY TECHNICAL.....	5
8600 MULTIFUNCTION BUTTON / FINGERSHIELD INSTALLATION.....	6
ROCKER SWITCH INFO / 8700 HANDING ID .....	7
8700 DOOR PREP AND ARM INFO.....	8
8600/8700 SERVICING WITH THE FPC902.....	9,10
8600/8700 PARTS LISTS.....	11,12
SIGNAGE REQUIREMENTS.....	13
WIRE DIAGRAMS.....	14,15,16,17



# 8600 Series OHC Swing Door Installation Instructions

## OPERATOR HANDING IDENTIFICATION—CENTER PIVOTED

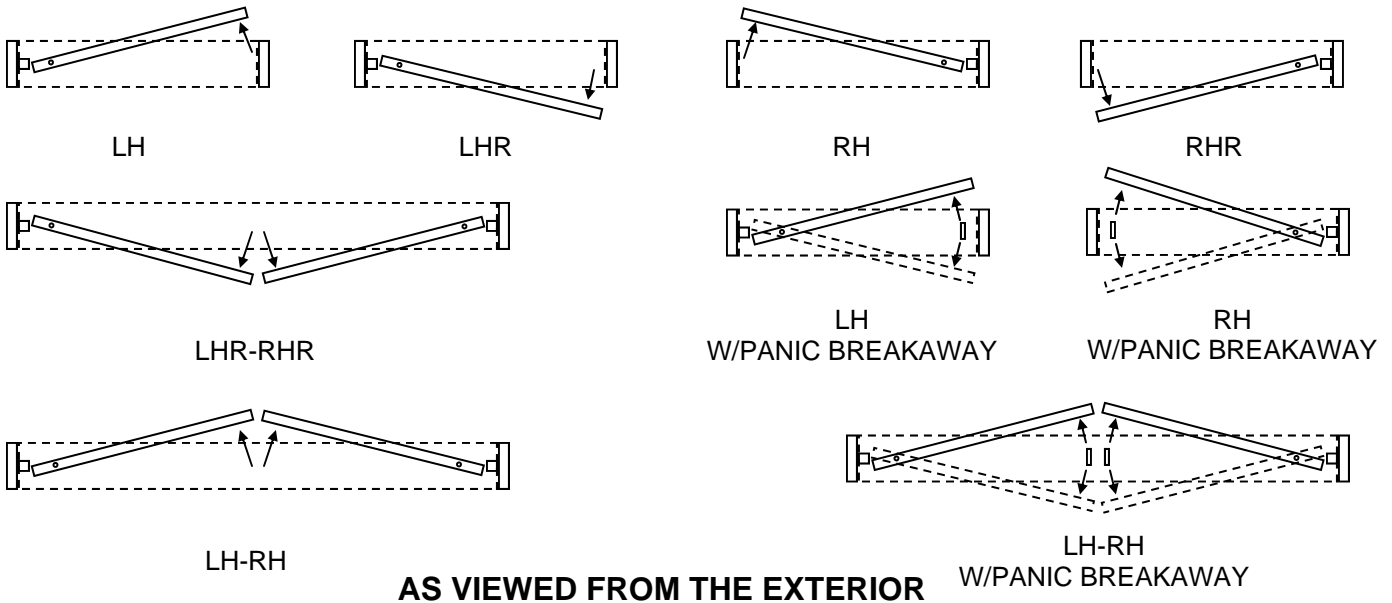

## AS VIEWED FROM THE EXTERIOR

### Electrical preparation

Before preparing jambs, determine the method and requirements for the electrical wiring involved and whether mats or other type of activation is used. Power Req.-115 VAC, 60Hz, 15 Amp service.

### Product Description

The record Series 8600/8700 Swing Door Operator is a power-open, spring-close unit providing full functionality conforming to either ANSI A156.10 or ANSI A156.19 requirements. The self-monitoring microprocessor-based control maintains precise regulation throughout the door open / close cycle. Two operators can be connected together in a master/slave configuration providing synchronized operation. Safety is additionally increased by the use of a redundant force limitation.

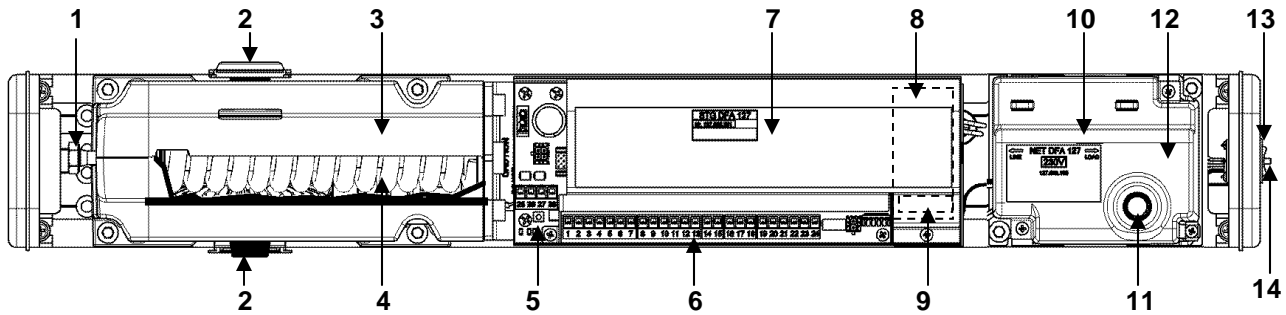

- |                                      |                                        |
|--------------------------------------|----------------------------------------|
| 1 Adjusting screw for spring tension | 8 Motor Drive Circuit Board            |
| 2 Output Shafts for Arms & Stop      | 9 Slide switch S1 (rotating direction) |
| 3 Drive Unit                         | 10 Power Supply                        |
| 4 Closing Spring                     | 11 Fuse ( 2.0A, 5X20mm, Slo-Blo)       |
| 5 Multifunction Pushbutton / Control | 12 Power Supply Circuit Board          |
| 6 Terminal Blocks for I/O            | 13 On / Off / Open Rocker Switch       |
| 7 Microprocessor Control             | 14 Status LED and Reset Pushbutton     |



# 8600 Series OHC Swing Door Installation Instructions

## Mounting the Header 8600

Measure opening to insure correct dimension for door height plus header size before placing and securing in position. Secure the Header through each end of header to door frame with the appropriate fasteners as indicated in diagrams of Header to Jamb Prep below.

## Door Prep 8600 Door Package

See below for Top & Bottom Door Prep.

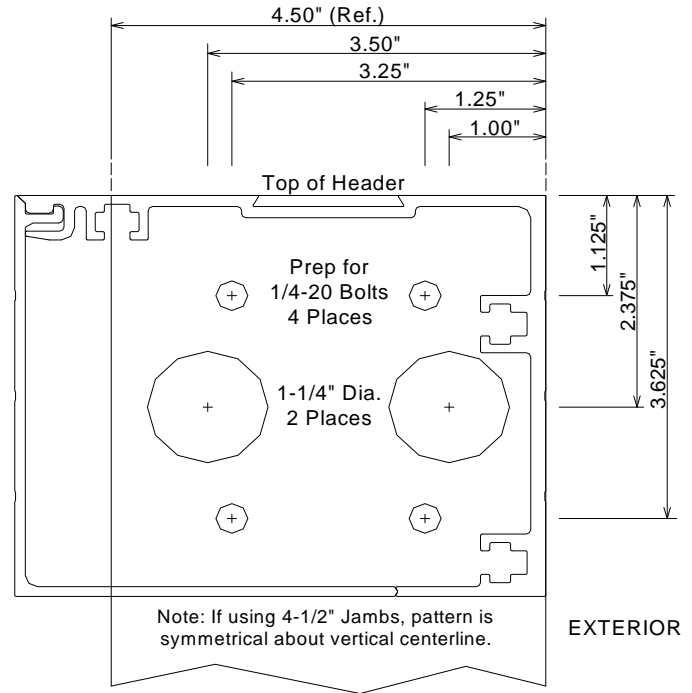

Recommend Rivnuts or Nutserts for 1/4-20 Prep for adequate support.

## TOP ARM DIMENSIONS

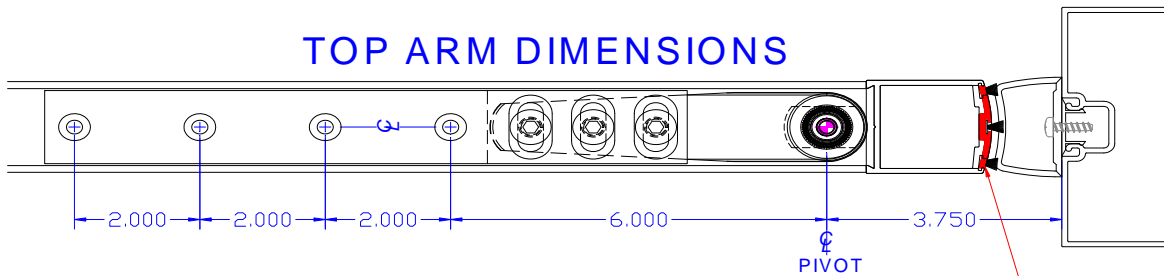

PREP FOR 1/4-20 BOLT - 4 PLACES  
IF DOOR WEB DOES NOT HAVE 1/4"  
THICK WALL TO RECEIVE 1/4-20 BOLTS,  
USE OF RIVNUTS OR NUTSERTS IS  
RECOMMENDED.

THE VERTICAL PIVOT RAIL OF THE DOOR  
SHOULD BE NOTCHED AT THE TOP AND  
BOTTOM 1-1/2" WIDE X 1" DEEP TO  
ACCOMMODATE END LOADING THE DOOR ONTO  
THE DRIVE ARM AND BOTTOM PIVOT.

## BOTTOM PIVOT DIMENSIONS

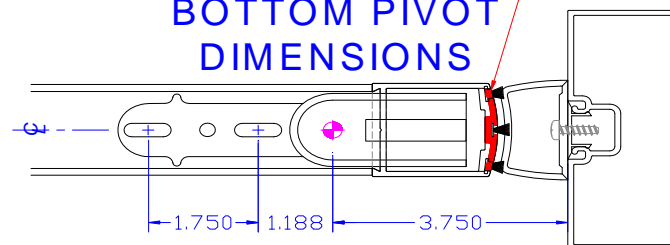

1" DEEP WEB  
REQUIRED - TOP  
AND BOTTOM  
HORIZONTALS



# 8600 Series OHC Swing Door Installation Instructions

## Operator Swing Direction

If the operator does not close slowly, the handing selection switch should be changed. It is located behind a slot in the sheet metal cover for the operator control –

With no power applied, the operator should be capable of being easily pushed open and when released, will close the door at a controlled speed.

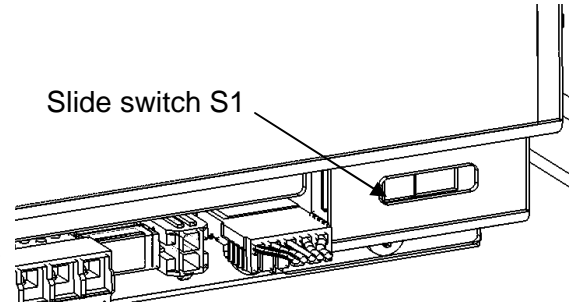

## Closing Spring Adjustment

The closing force provided by the spring is adjustable.

Do not adjust the force so low that the door will not consistently close under spring power.

On a typical 3'-0" door with a standard arm assembly, the spring closing force can be adjusted from less than 5 pounds force to more than 20 pounds force, measured at the leading edge of the door.

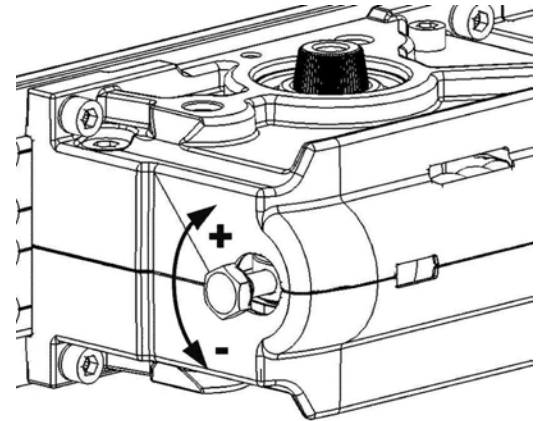

## Open Stop

The unit is provided with an adjustable full open stop. Rotate the door to the full open position; mount the Shaft Stop onto the upper output shaft and against the Fixed Stop. The spline of the output shaft allows indexing in 6° increments. For finer adjustment, the Fixed Stop is slightly eccentric; loosen and rotate until the desired stop location is achieved and re-tighten.

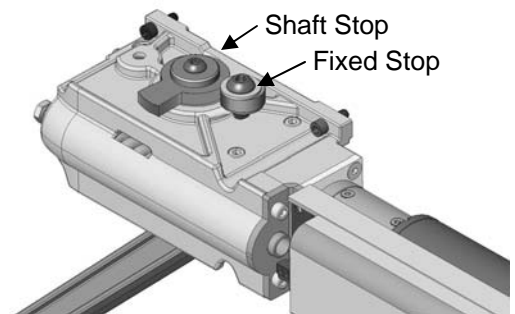

For installations where severe physical abuse may occur (such as extreme wind conditions), it is suggested a floor mounted stop be installed at full open. Additionally, the operator full open stop can be set at 100 degrees or more of opening, and program the operator to electronically stop at the 90 degree full open position. This can be accomplished by manually stopping the door at 90 degrees during a calibration run, or by reducing the opening angle under the parameter "Drive / Opening angle" (using an FPC902 Hand Terminal or a Display Control Panel).

## Power Supply Connection

Connect 115VAC, 60 Hz, 10A, to Power Supply terminal strip

- 115VAC "Hot" (Line) to "L" terminal;
- 115VAC "Neutral" to "N" terminal

The second "L" and "N" terminals provide a convenient junction for dual operator systems. Proper grounding must be provided for the unit. A grounding tab and screw are located adjacent to the Power Supply terminal strip.

The power supply cover must be installed after connecting 115VAC primary service.

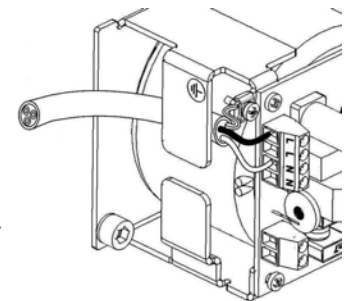



# 8600 Series OHC Swing Door Installation Instructions

The **multifunction pushbutton** can be used for the following functions:

1 flash of the red LED will actuate a standard open cycle (if the rocker switch is on).

3 flashes of the red LED will initiate a calibration run.

4 flashes of the red LED will initiate the parameter adjust mode of a Display Control Panel.

8 flashes of the red LED will reset the unit's parameters to factory defaults.

15-17 flashes will cause the unit to reset without affecting any of the field set parameters.

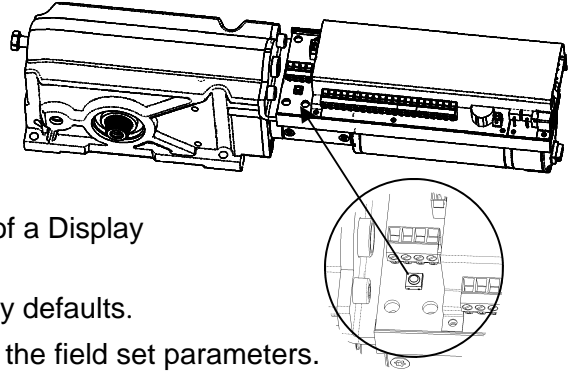

**After completion of the mechanical installation and prior to adjusting the parameters, always initiate a calibration run by pressing and holding the pushbutton for 3 flashes of the red LED. This will insure proper door operation by calibrating the unit to the installation conditions.**

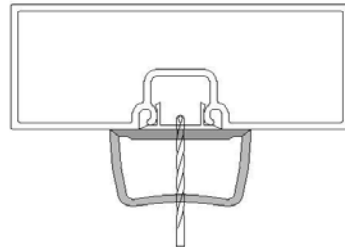

Drill 9/64" through center of fingerguard on spacings shown at right.

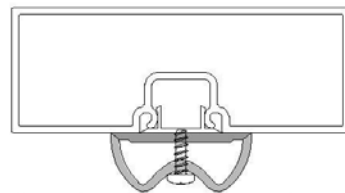

Insert screw, compressing fingerguard until screw contacts aluminum, then tighten slowly and allow head to swage through flexible section of fingerguard.

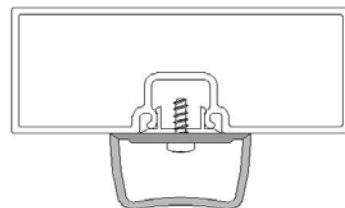

Continue to tighten screw to secure in place. Do not over-tighten as screw head will compress pinch rigid section of fingerguard, resulting in pulling away from aluminum.

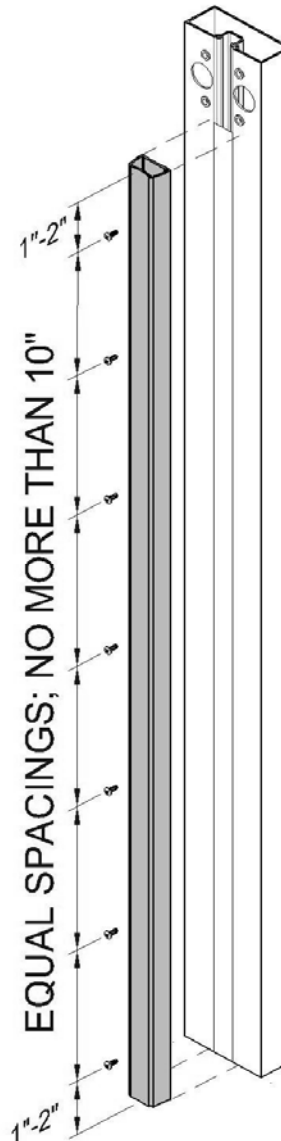



# 8600/8700 Series OHC Swing Door Installation Instructions

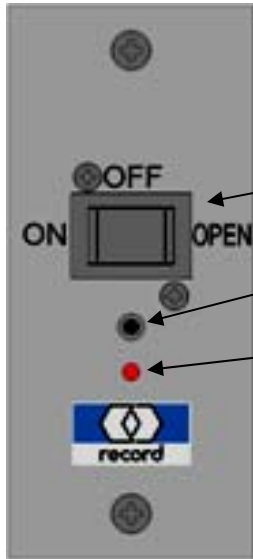

The Series 8600 Standard Rocker Switch Control Panel includes:

3 Position Rocker Switch - ON / OFF / OPEN mounted to Jamb mount Faceplate.

Pushbutton - To reset the operator, press and hold for 8 seconds

LED (red) - Normally off; flashing indicates either the unit is performing a calibration run, or an error has been encountered.

To clear an error, press & hold the pushbutton for approximately 8 seconds, or until the LED turns off.

## 8700 OPERATOR HANDING IDENTIFICATION—CONTINUOUS HINGE

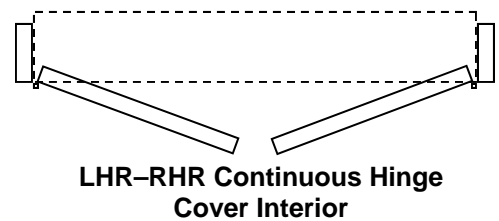
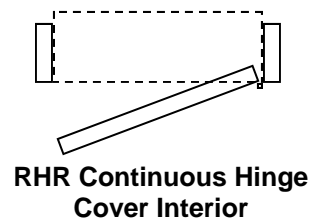
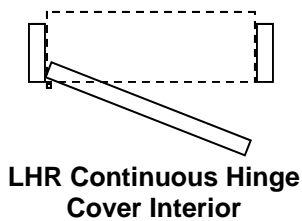
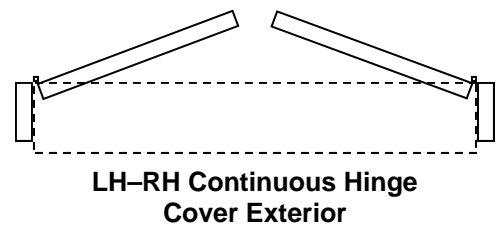
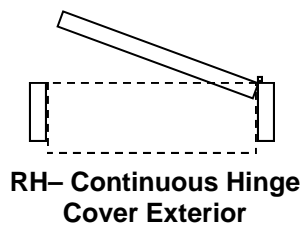
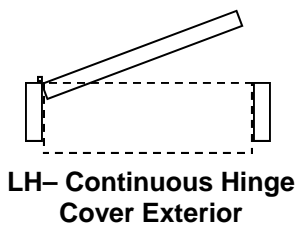

AS VIEWED FROM THE EXTERIOR



# 8700 Series OHC Swing Door Installation Instructions

## TOP OF DOOR—TRACK PREP

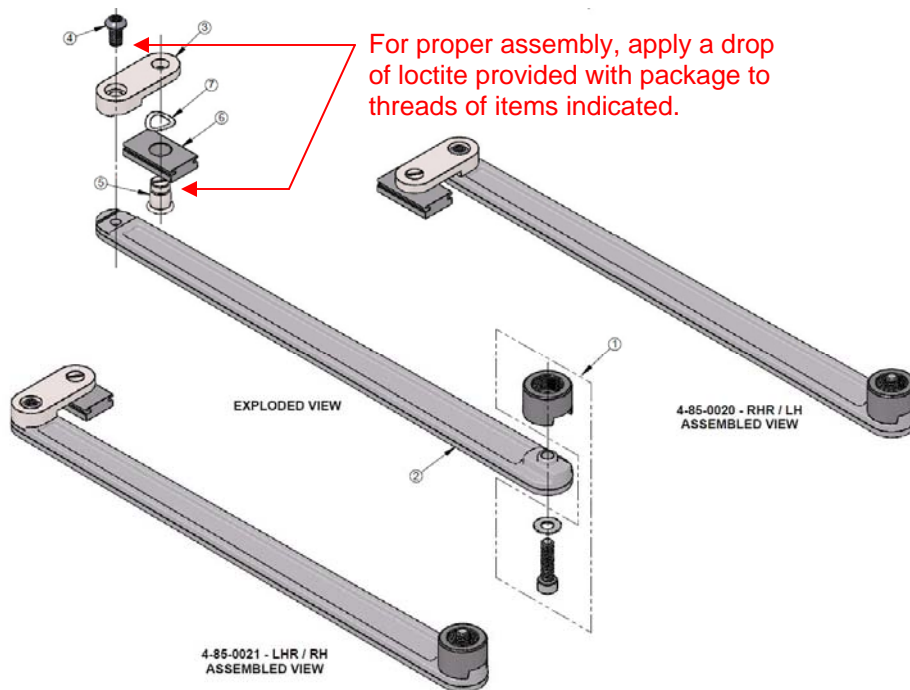
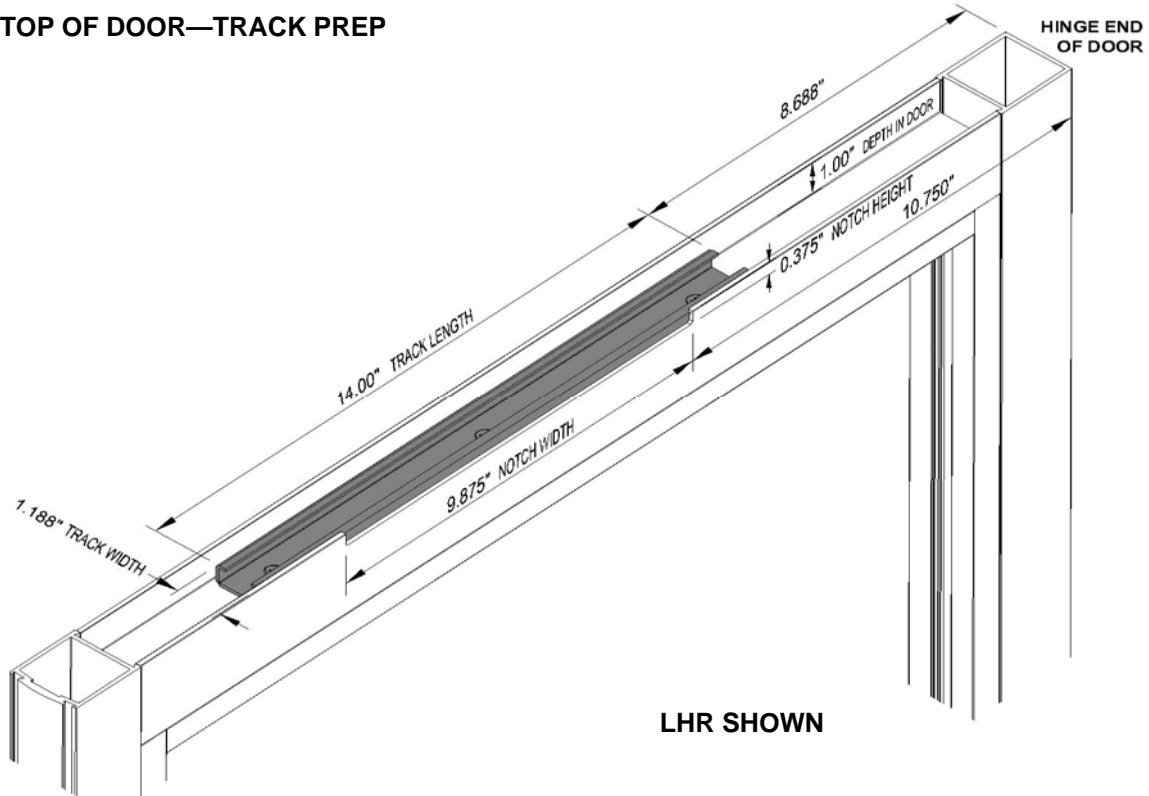

1	9-80-0006	Adaptor, Drive Arm, 20 mm	5	4-20-1090	Arm, Stud
2	4-85-1009	Slide Arm, (Butt Hung)	6	4-24-9003	Slide Block
3	4-85-1008	Extension, Slide Arm, (Butt Hung)	7	9-99-7356	Washer, Wave Spring
4	9-99-1822	M8 - 1.25 x 16 BSHCS	8	9-01-0001	Loctite 222, Purple Threadlocker



After the operator has been mechanically installed, the arms attached to the door, and 120VAC connected to the power supply, connect the FPC902 Hand Terminal to the operator control. The following sequence of screens will occur. The final screen shown below is the base point from which various settings for the operator are accessed and modified.

```
AKKU          PASS
FLASH        PASS
EEPROM       PASS
RTC          PASS
CAN         PASS
```

```
FPC902
Version 1.26
Nov 24 2006
10:48:48
```

```
FPC902
Service STG >
Service STG Slave >
Flash-Programmer >
Setup >
```

**Press "OK", or scroll down to STG Slave and press "OK"**

```
Connect with STG ...
■■■■■■■■□□□□□□
```

```
Accept all parameter
from the STG?

Offline Yes
```

**Press "OK"**

```
Parameter download
from STG ...
■■■■■■■■□□□□□□
```

```
DFA127 V1.32 M
  2 2
USA Low Energy
Manual
0 Errorless
Continue
```

**Press "OK"**

```
SERVICE STG
  2 2
Parameter >
Maintenance >
Functions >
Operation mode >
Diagnostics >
```

The following page indicates suggested parameter configurations for a typical installation. For a detailed description of all the parameters, consult the instructions with the FPC-902.

The following documents the suggested sequence of programming the operator:

The Series 8500 is shipped configured for a combination operation designated as "USA Low Energy". If manual operation of the door is not desired (with 120VAC power present), this should be changed to "USA", as shown in the sequence at right.

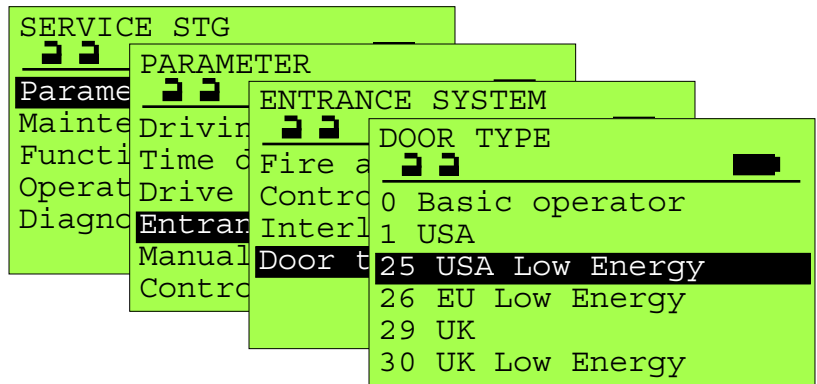

If a pair of operators are to be operated simultaneously, and only one rocker switch is to be used, it should be connected to the master control, and the slave control must be set as shown at right, allowing it to function without a rocker switch.

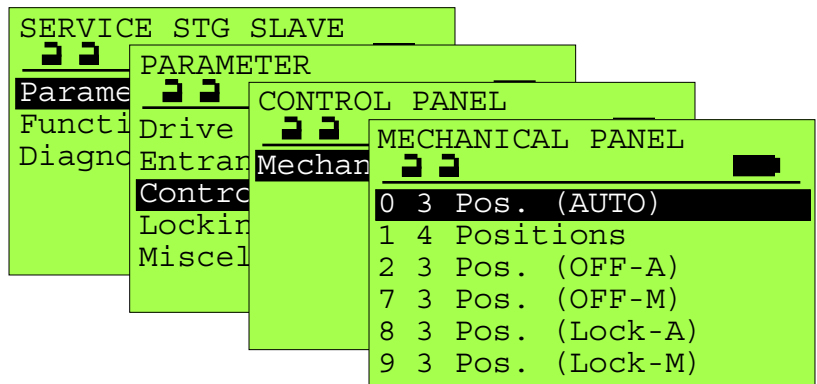

If automatic operation in response to pushing the door is desired (Push-To-Start), select "Miscellaneous", then "Push to Actuate" and enable by selecting "2 Normal". Note on paired units, this option must be set individually for both operators.

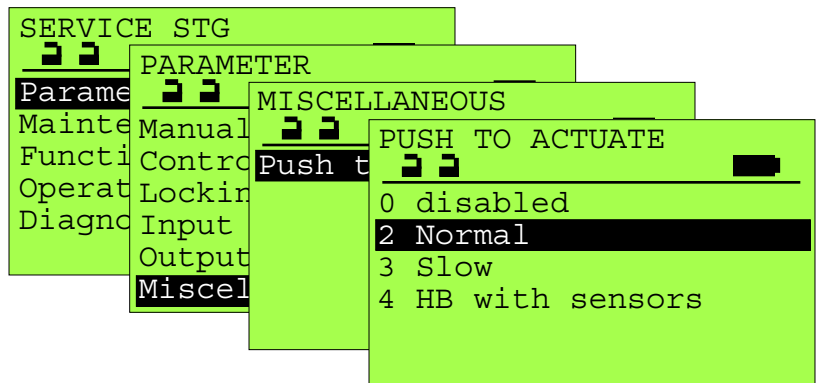

The unit is defaulted to include support for an automatic lock. If one is not provided, select the "Locking" parameter, then "Locking Functions", and change from "3 Always locked" to "1 Night locked" to eliminate the delay before opening.

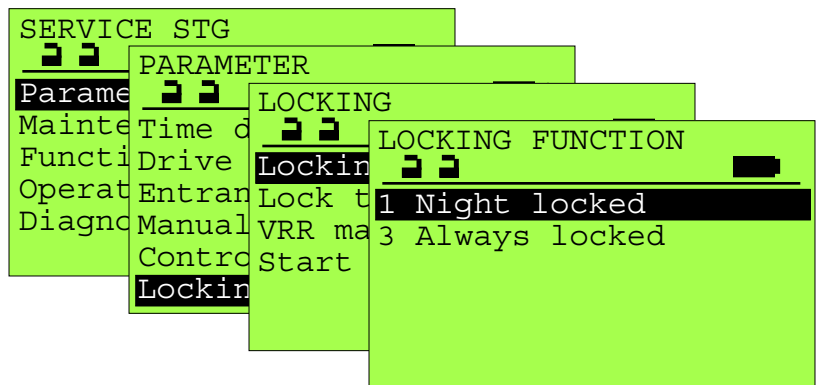

The unit(s) are now ready to be placed into operation. Turn the control panel "on", press and hold the Control Button on the door control for 3 blinks of the adjacent LED. This will initiate a calibration cycle of the operator. After a few seconds the operator should open slowly, with a short pulse during mid-opening. It should be allowed to complete this cycle without interruption.

Note: Calibration must be performed individually on both operators of a pair.

The Series 6100 and 8000 Instructions included with the FPC-902 Terminal will have a complete listing of the screens, options, and adjustments available for this operator.

# 8600 Series OHC Swing Door Installation Instructions

## SERIES 8500 8600 OHC SWING DOOR OPERATOR

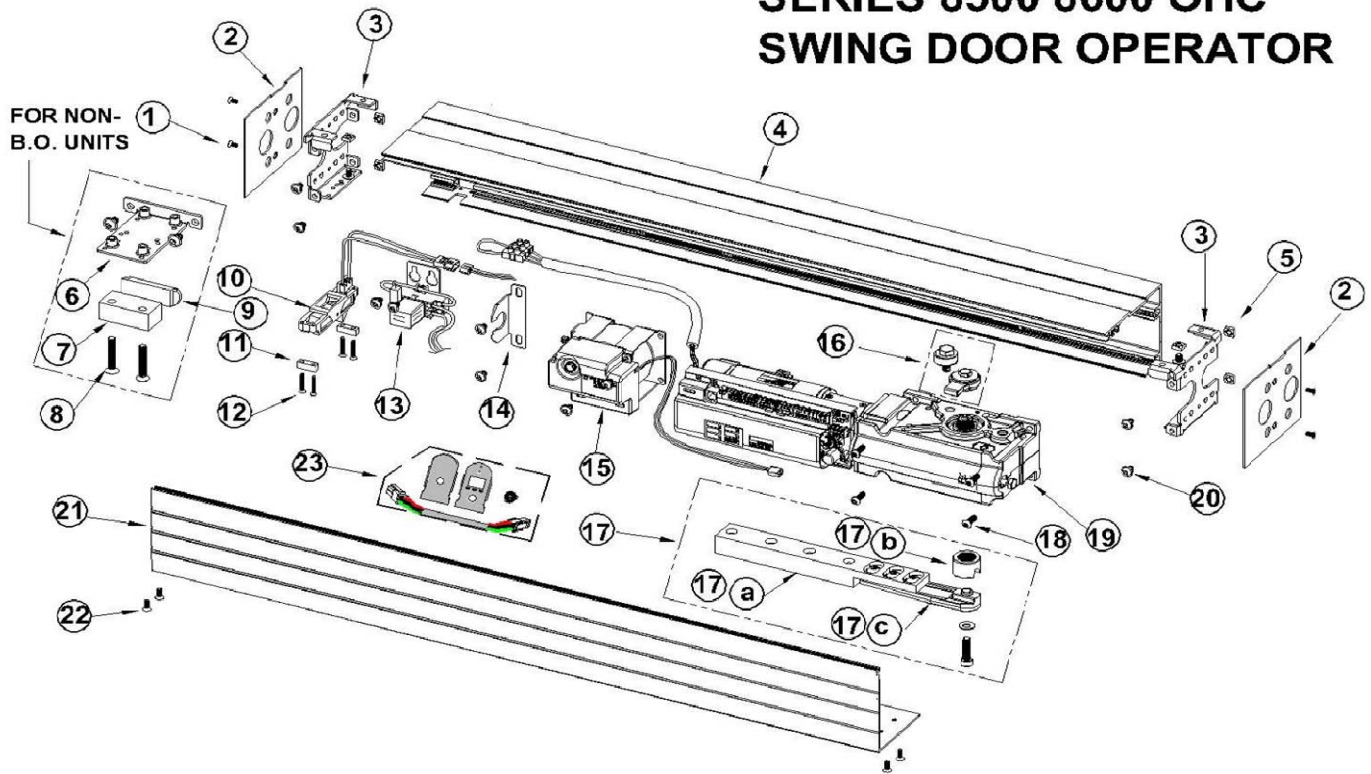

1	81-0012-0404	Screw, 8-32x1/4" Ph, FH,UC,MS	17	4-85-0019	Drive Arm Assy., OHC, <b>Complete</b>
2	4-85-1010	End Cap, Header, OHC	17a	4-85-1007	Door Arm, OHC
3	4-85-1002	Bracket, Header to Jamb	17b	9-80-0006	Arm Adaptor, 20mm (1/2")
4	5-85-4003	Header Extrusion, OHC, CL-DB	17c	4-85-1006	Drive Arm, OHC
5	9-99-3507	Nut Plate, 1/4-20	18	81-0014-2666	Screw, 1/4-20x3/4" BH, CS
6	4-85-0022	Bracket Assy., Door Closed Stop	19	4-85-0101	Drive Module w/ Control, OHC
7	4-85-4020	Block, Door Closed Stop	<b>19a</b>	4-85-0102	Drive Module w/ Control, OHC <b>w/Brake</b>
8	81-0011-0676	Screw, 1/4-20x1 1/2" Ph,FH,MS	20	81-0017-2658	Screw, 1/4-20x3/8", BH, CS
9	9-99-2594	Pad, Foam Rubber	21	5-85-4004	Cover Extrusion, OHC, CL-DB
10	9-73-0074	Breakout Stop w/Switch	22	81-0012-0562	Screw, 10-32x1/2", Ph, FH, MS
11	4-85-9003	Block, Breakout Stop Mounting	23	4-80-0811	Kit, Harness Extension, FPC902
12	81-4811-0420	Screw, 8-16x1" Ph, FH, Plastite	~	4-85-0803	Kit, Fixed Stop, OHC, # 6,7,8,9
13	4-80-0101	Relay Assy., Panic Breakout	~	4-85-0804	Kit, Breakout, Panic Stop, OHC #10,11,12,13
14	4-51-1004	Bracket, Conduit Anchor	~	9-90-0000	Pivot Assy., Bottom, Center, OHC
15	9-80-0102	Power Supply	~	4-85-0806	Kit, On/Off/Open, Rocker Switch, Jamb
16	9-80-0103	Kit, Hard Stop	~	4-80-0809	Kit, On/Off/Open, Keyswitch, Dual
			~	4-85-9001	Fingerguard, 7' S/L

# 8700 Series OHC Swing Door Installation Instructions

## SERIES 8500/8700 BUTT- HUNG SWING DOOR OPERATOR

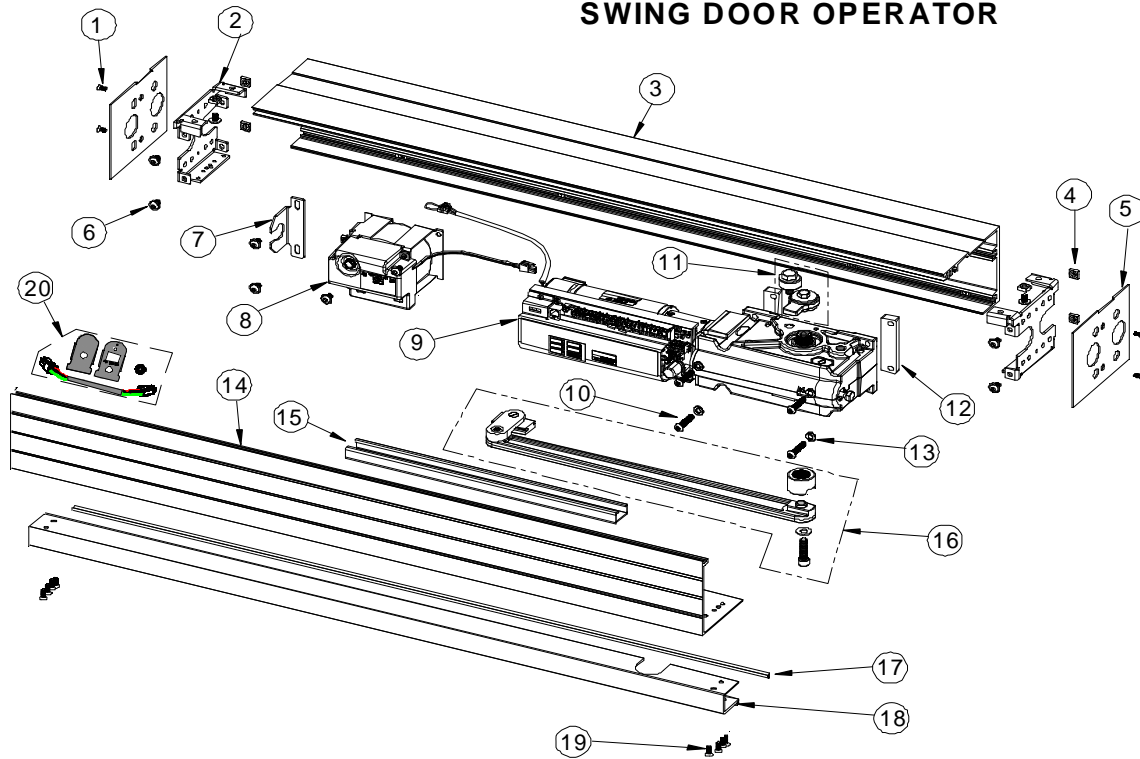

1	81-0012-0404	Screw, 8-32x1/4" Ph, FH,UC,MS	12	4-85-4021	Spacer, Operator Body
2	4-85-1002	Bracket, Header to Jamb	13	9-99-7182	Washer, Lock, 1/4"
3	5-85-4003	Header Extrusion, OHC, CL-DB	14	5-85-4004	Cover Extrusion, OHC, CL-DB
4	9-99-3507	Nut Plate, 1/4-20	15	4-30-1010	Track, Slide Arm
5	4-85-1010	End Cap, Header, OHC	16	4-85-0021	Slide Arm Assy., Butt Hinge, RH
6	81-0017-2658	Screw, 1/4-20x3/8", BH, CS	16a	4-85-0020	Slide Arm Assy., Butt Hinge, LH
7	4-51-1004	Bracket, Conduit Anchor	17	9-99-7318	Weatherpile, Door Catch, DB
8	9-80-0102	Power Supply	18	4-85-4022	Cover, Slide Arm, CL-DB, RH
9	4-85-0101	Drive Module w/ Control, OHC	18a	4-85-0023	Cover, Slide Arm, CL-DB, LH
<b>9a</b>	4-85-0102	Drive Module w/ Control, OHC <b>w/Brake</b>	18b	4-85-0024	Cover, Slide Arm, CL-DB, Dual
10	81-0014-2674	Screw, 1/4-20x1 1/4", BH CS	19	81-0012-0562	Screw, 10-32x1/2", Ph, FH, MS
11	9-80-0103	Kit, Hard Stop	20	4-80-0811	Kit, Harness Extension, FPC902
~	9-99-2801	Continuous Hinge, CL-DB,83"	~	4-24-9003	Slide Block, Arm Assy.
~	9-99-2802	Continuous Hinge, CL-DB,95"	~	4-85-0805	Kit, Header Accessories, OHC, Butt Hung

# 8600/8700 SIGNAGE REQUIREMENTS



Full Power & Low Energy  
"Knowing Act" doors



Full Power - Swing  
Side, 2-Way Traffic;  
Low Energy - Sensor  
Activation



Full Power  
Approach Side



Full Power  
Non-Approach Side

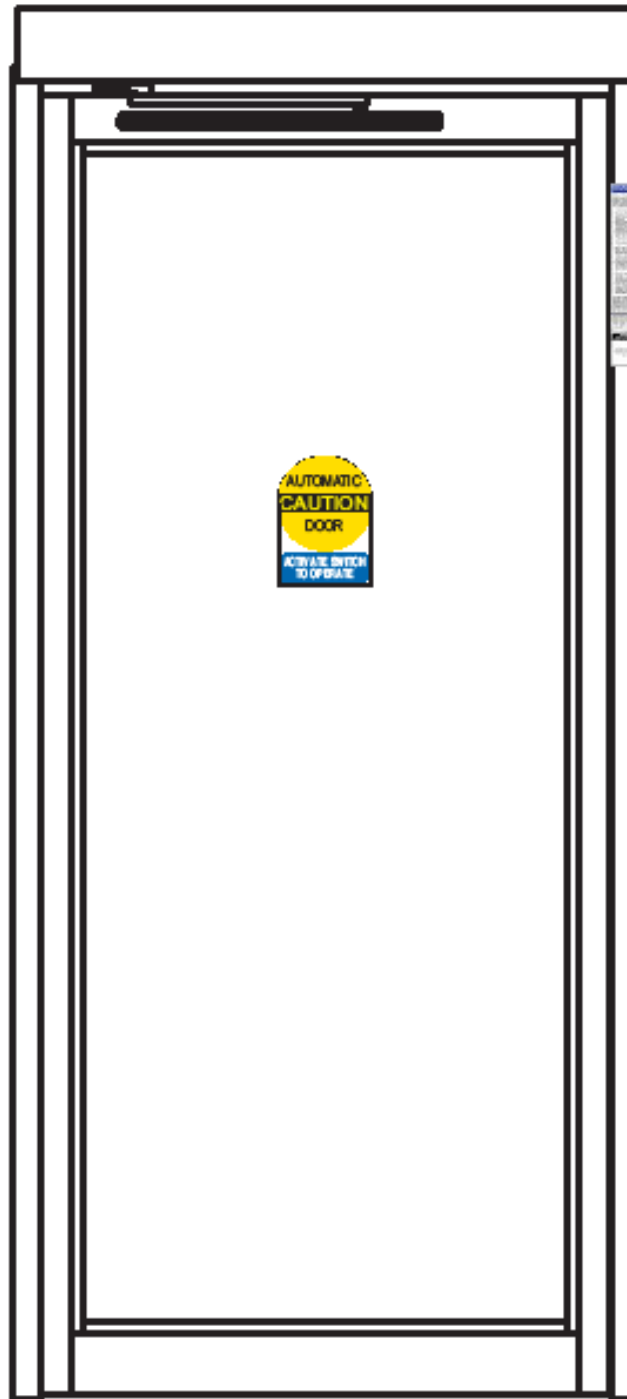

Daily Safety  
Check locate  
below control  
panel

58"  
±5"

**SAFETY DECAL  
REQUIREMENTS**

Oct06

# CONTROL TERMINAL BLOCK CONNECTIONS

- 1 - Approach Sensor - Power/Signal - +24V
- 2 - Approach Sensor - Signal
- 3 - Approach Sensor - Power - 0V
- 4 - Guide Rail Beam - Power/Signal - +24V
- 5 - Guide Rail Beam - Signal
- 6 - Guide Rail Beam - Power - 0V
- 7 - Remote Switch - Signal
- 8 - Header Mounted Swing Side Safety - Signal
- 9 - BodyGuard Data Line - Data +
- 10 - Door Mounted Swing Side Safety - Signal
- 11 - Door Mounted Sensors - Power/Signal - +24V
- 12 - Door Mounted Approach Side Recycle - Signal
- 13 - Door Mounted Sensors - Power - 0V
- 14 - Fire Alarm Signal (Jumper to 15 if not used)
- 15 - Fire Alarm - +24V
- 16 - Door Alarm Relay - N.O.
- 17 - Door Alarm Relay - COM
- 18 - Door Alarm Relay - N.C.
- 19 - Automatic Lock Power - 0V (0.5A Max.)
- 20 - Automatic Lock Control Relay - N.O.
- 21 - Automatic Lock Control Relay - COM
- 22 - Automatic Lock Control Relay - N.C.
- 23 - Automatic Lock Monitor Signal
- 24 - Automatic Lock Power/Signal - +24V

There are three levels of resetting an operator. To reset without changing any operating parameters, press & hold the black reset button (next to the ON/OFF rocker switch) for 6 seconds, until relay "clicks" occur. To reset and restore typical operating parameters (speed, master/slave, etc.), press & hold the blue button (on the door control) for 8 flashes of the red LED. To fully reset the unit, eliminating all parameter modifications (including Series 6100/8000 setting), press & hold the blue button on the control for 9 flashes of the red LED, then immediately remove the jumper between terminals 14 & 15. After a full reset, the parameter "Entrance System / Door Type" must be changed from "0 Basic Operator" to "25 USA Low Energy". Additional parameters, including factory settings, will also have to be re-entered. Consult factory for additional details.

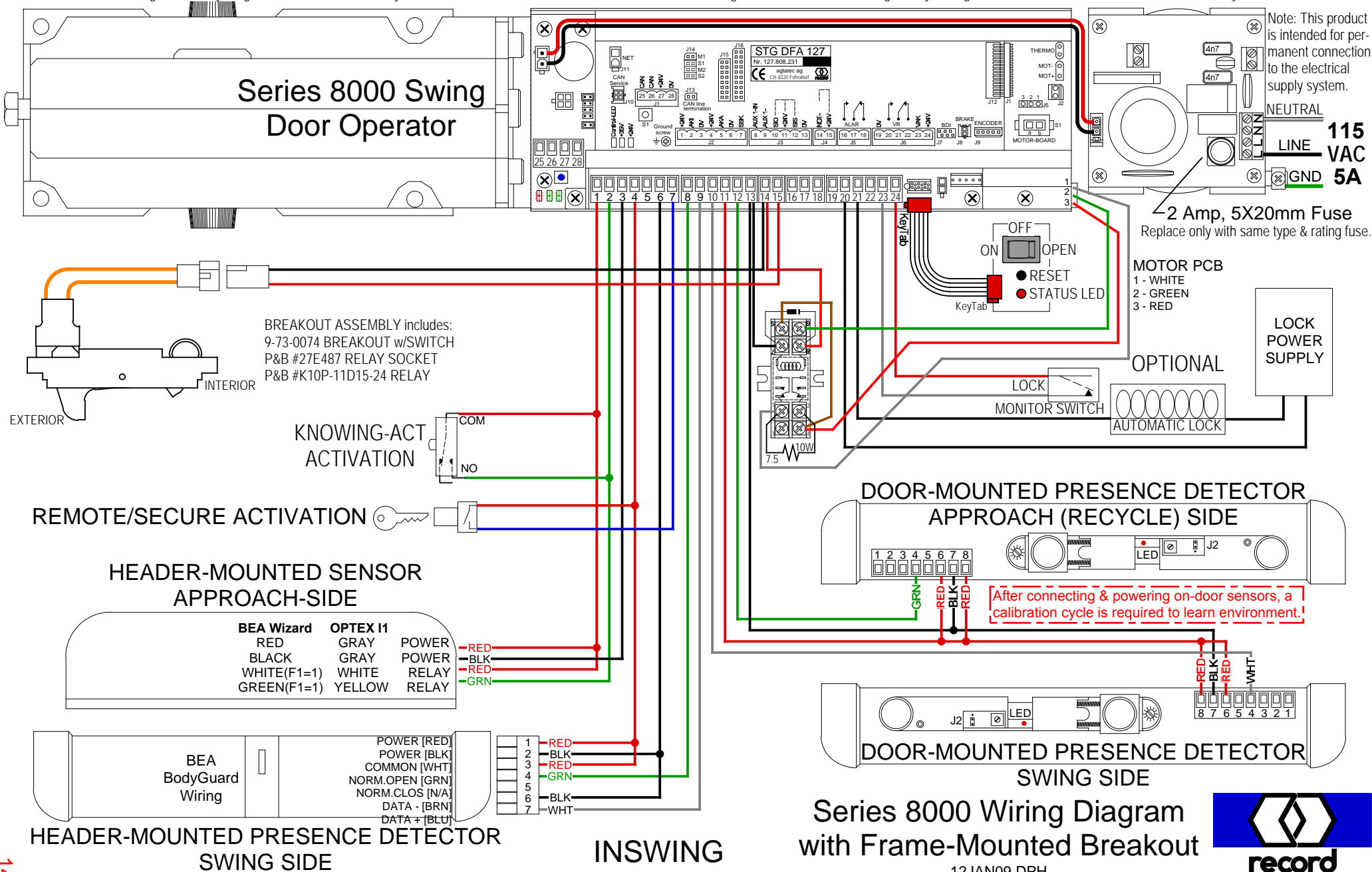

Note: This product is intended for permanent connection to the electrical supply system.

Series 8000 Wiring Diagram with Frame-Mounted Breakout  
 12JAN09 DPH



# CONTROL TERMINAL BLOCK CONNECTIONS

- 1 - Approach Sensor - Power/Signal - +24V
- 2 - Approach Sensor - Signal
- 3 - Approach Sensor - Power - 0V
- 4 - Guide Rail Beam - Power/Signal - +24V
- 5 - Guide Rail Beam - Signal
- 6 - Guide Rail Beam - Power - 0V
- 7 - Remote Switch - Signal
- 8 - Header Mounted Swing Side Safety - Signal
- 9 - BodyGuard Data Line - Data +
- 10 - Door Mounted Swing Side Safety - Signal
- 11 - Door Mounted Sensors - Power/Signal - +24V
- 12 - Door Mounted Approach Side Recycle - Signal
- 13 - Door Mounted Sensors - Power - 0V
- 14 - Fire Alarm Signal (Jumper to 15 if not used)
- 15 - Fire Alarm - +24V
- 16 - Door Alarm Relay - N.O.
- 17 - Door Alarm Relay - COM
- 18 - Door Alarm Relay - N.C.
- 19 - Automatic Lock Power - 0V (0.5A Max.)
- 20 - Automatic Lock Control Relay - N.O.
- 21 - Automatic Lock Control Relay - COM
- 22 - Automatic Lock Control Relay - N.C.
- 23 - Automatic Lock Monitor Signal
- 24 - Automatic Lock Power/Signal - +24V

There are three levels of resetting an operator. To reset without changing any operating parameters, press & hold the black reset button (next to the ON/OFF rocker switch) for 6 seconds, until relay "clicks" occur. To reset and restore typical operating parameters (speed, master/slave, etc.), press & hold the blue button (on the door control) for 8 flashes of the red LED. To fully reset the unit, eliminating all parameter modifications (including Series 6100/8000 setting), press & hold the blue button on the control for 9 flashes of the red LED, then immediately remove the jumper between terminals 14 & 15. After a full reset, the parameter "Entrance System / Door Type" must be changed from "0 Basic Operator" to "25 USA Low Energy". Additional parameters, including factory settings, will also have to be re-entered. Consult factory for additional details.

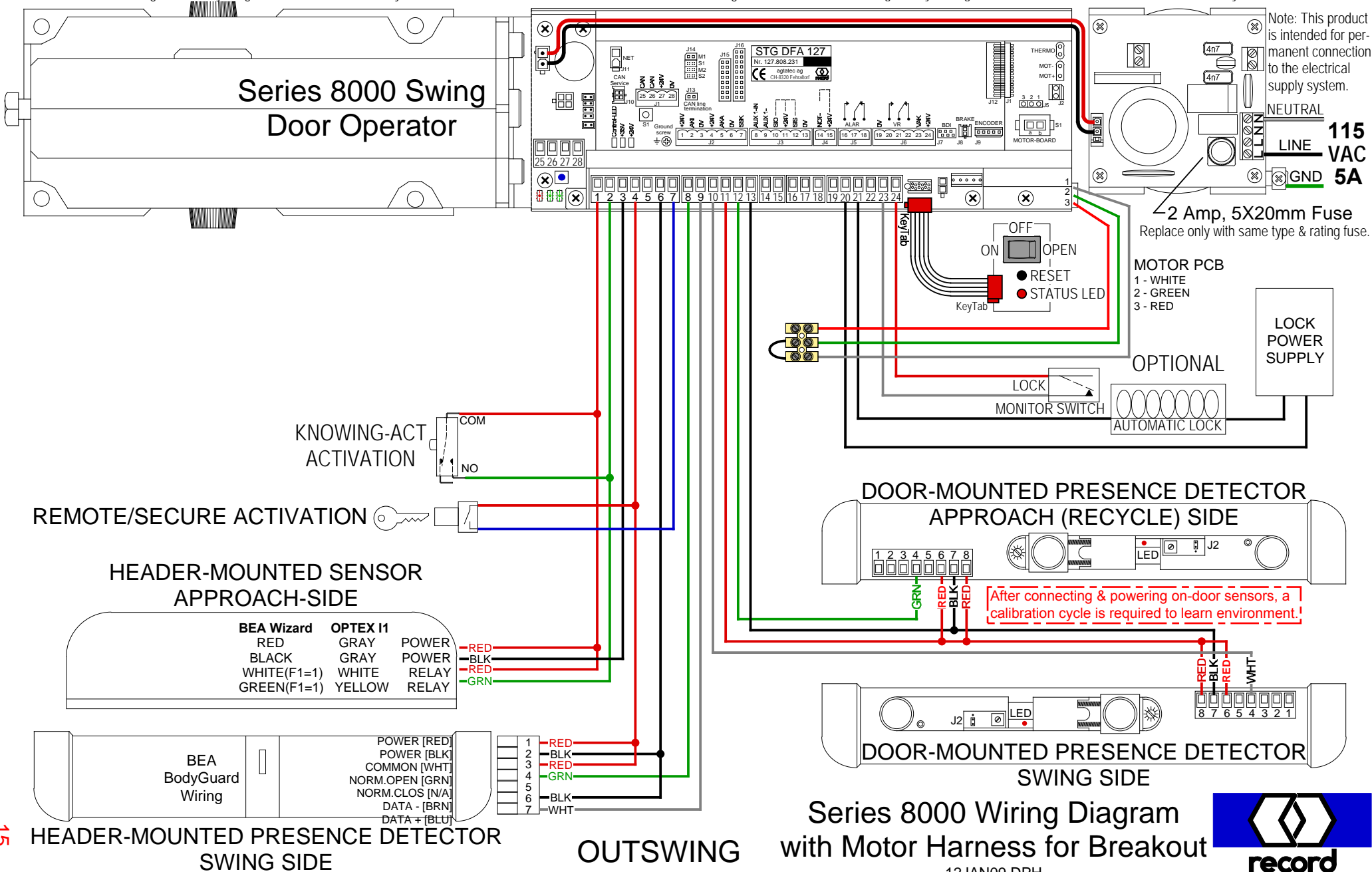

Note: This product is intended for permanent connection to the electrical supply system.

NEUTRAL  
LINE 115 VAC  
GND 5A

2 Amp, 5X20mm Fuse  
Replace only with same type & rating fuse.

## Series 8000 Wiring Diagram with Motor Harness for Breakout

12JAN09 DPH





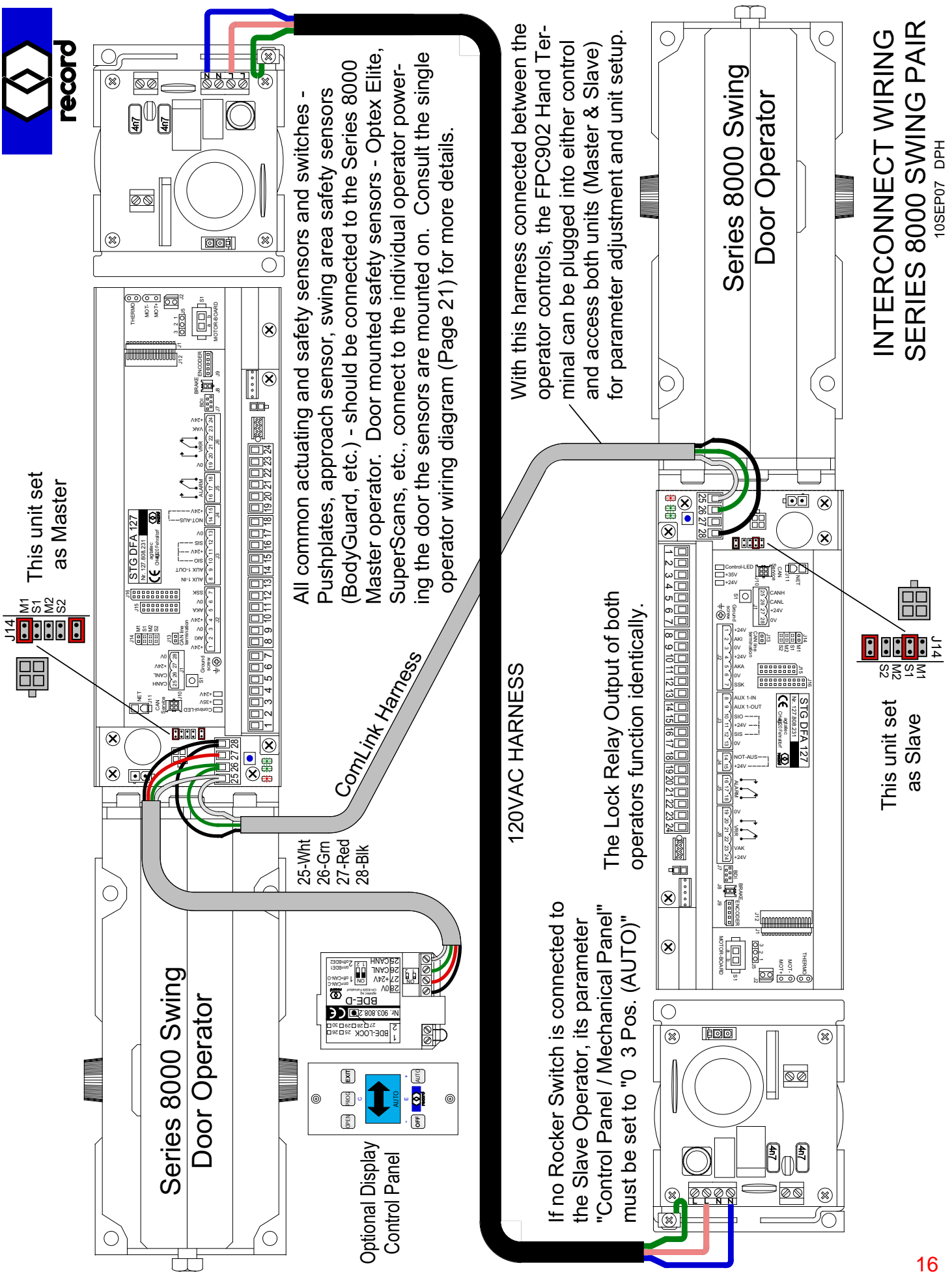

All common actuating and safety sensors and switches - Pushplates, approach sensor, swing area safety sensors (BodyGuard, etc.) - should be connected to the Series 8000 Master operator. Door mounted safety sensors - Optex Elite, SuperScans, etc., connect to the individual operator powering the door the sensors are mounted on. Consult the single operator wiring diagram (Page 21) for more details.

**120VAC HARNESS**

If no Rocker Switch is connected to the Slave Operator, its parameter "Control Panel / Mechanical Panel" must be set to "0 3 Pos. (AUTO)"

The Lock Relay Output of both operators function identically.

With this harness connected between the operator controls, the FPC902 Hand Terminal can be plugged into either control and access both units (Master & Slave) for parameter adjustment and unit setup.

**INTERCONNECT WIRING  
SERIES 8000 SWING PAIR**  
10SEP07 DPH

## CONTROL TERMINAL BLOCK CONNECTIONS

- 1 - Approach Sensor - Power/Signal - +24V
- 2 - Approach Sensor - Signal
- 3 - Approach Sensor - Power - 0V
- 4 - Guide Rail Beam - Power/Signal - +24V
- 5 - Guide Rail Beam - Signal
- 6 - Guide Rail Beam - Power - 0V
- 7 - Remote Switch - Signal
- 8 - Header Mounted Swing Side Safety - Signal
- 9 - Body/Guard Data Line - Data +
- 10 - Door Mounted Swing Side Safety - Signal
- 11 - Door Mounted Sensors - Power/Signal - +24V
- 12 - Door Mounted Approach Side Recycle - Signal
- 13 - Door Mounted Sensors - Power - 0V
- 14 - Fire Alarm Signal (Jumper to T5 if not used)
- 15 - Fire Alarm - +24V
- 16 - Door Alarm Relay - N.O.
- 17 - Door Alarm Relay - COM
- 18 - Door Alarm Relay - N.C.
- 19 - Automatic Lock Power - 0V (0.5A Max.)
- 20 - Automatic Lock Control Relay - N.O.
- 21 - Automatic Lock Control Relay - COM
- 22 - Automatic Lock Control Relay - N.C.
- 23 - Automatic Lock Monitor Signal
- 24 - Automatic Lock Power/Signal - +24V

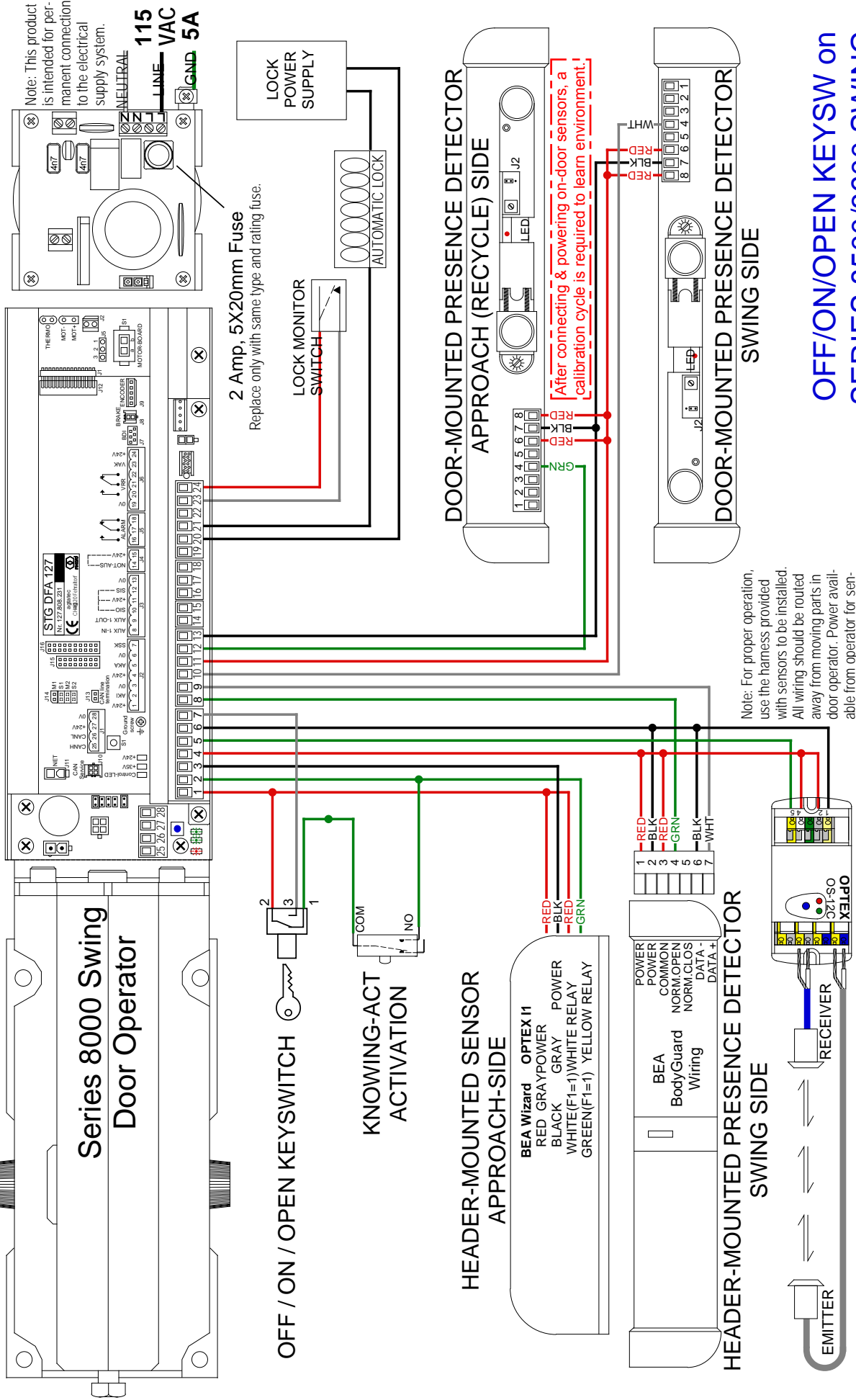

**OFF/ON/OPEN KEYSW on  
 SERIES 8500/8600 SWING**