

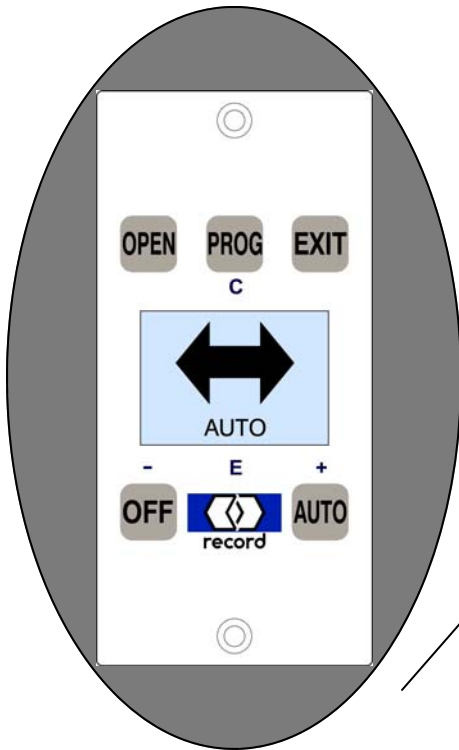

5100 Series Sliding Door Installation Instructions

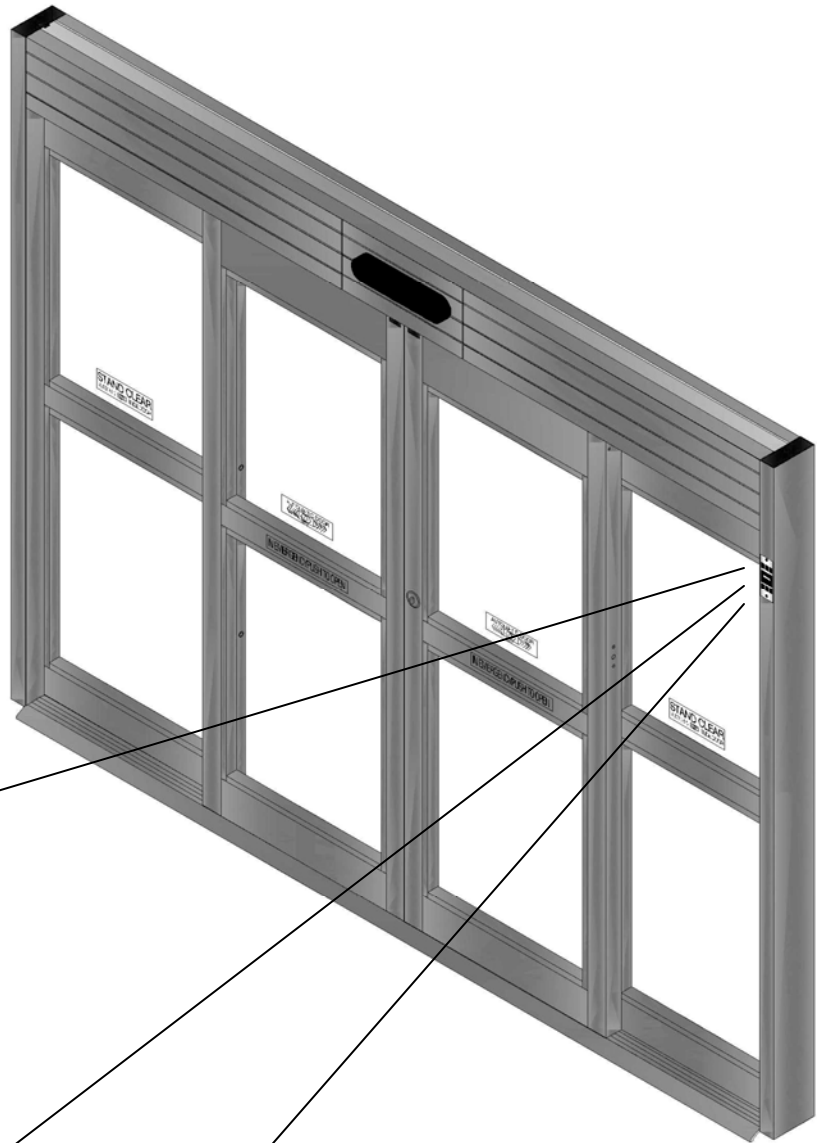



5100 Series Sliding Door Installation Instructions

The record-usa 5100 slider has been carefully designed, built, and tested to provide years of service.

The life of the door package is directly related to how carefully the installation is accomplished and how accurately the instructions are followed. Installation of this door package is to be performed by properly trained and experienced installers knowledgeable with local code requirements and all requirements of ANSI A156.10 Standards for Power Operated Pedestrian Doors. The authorized service / installation dealer must perform all measurements for forces, speeds, and times to insure proper and safe operation.

record-usa is not responsible for improperly adjusted or maintained automatic doors or activation / safety systems and assumes no responsibility for damages caused by automatic door systems that have not been properly installed, tested, and adjusted.

Verify the door may be opened without power applied to the unit.

Verify the force required to open the door with power disconnected shall not be greater than 50 pounds.

Verify the door does not develop kinetic energy in excess of 7 foot-pounds.

Verify the door does not require a force greater than 30 pounds applied in either direction to prevent the door from closing.

OWNER INFORMATION TO BE PROVIDED BY THE DISTRIBUTOR / INSTALLER

- * After the installation instruct the owner on the safe operation of the door.
- * Location and proper use of the power switches.
- * Location of the main cutoff breaker.
- * Necessary warnings not covered in general instructions.
- * Owners Manual and Daily Safety Checklist.
- * Phone number(s) for the local servicing dealer.
- * What to do in the event that a dangerous situation should occur, and how to shut the doors down and call for service.

NOTE: GLASS AND GLAZING ARE NOT INCLUDED IN THE PACKAGE.
THE GLAZING MATERIALS IN BOTH THE DOORS AND SIDELITES SHALL COMPLY WITH THE REQUIREMENTS IN THE AMERICAN NATIONAL STANDARD PERFORMANCE SPECIFICATIONS AND METHODS OF TEST FOR SAFETY GLAZING MATERIALS USED IN BUILDINGS, Z97.1.1975

TABLE OF CONTENTS

OWNER INFORMATION / TABLE of CONTENTS.....	2
TOOL LIST / GENERAL REQUIREMENTS.....	3
PRODUCT INVENTORY AND PREPARATION.....	4
FRAME AND TRANSOM ASSEMBLY.....	5
FRAME INSTALLATION & ATTACHMENT.....	6
BOTTOM GUIDE INSTALLATION.....	7
SIDELITE INSTALLATION.....	8
SLIDING DOOR INSTALLATION.....	9
COVER ATTACHMENT & FINAL NOTES.....	10
SLIDING DOOR PRELOAD & BLOCKING ADJUSTMENT....	11
DISPLAY UNIT OPTIONS.....	12
COMMISSIONING.....	13,14,15
REMOTE CONTROL OPTIONS.....	16
SAFETY SENSOR WIRING.....	17,18
CONTROL PANEL SCREENS.....	19
SIGNAGE REQUIREMENTS.....	20
WIRE DIAGRAM.....	21



5100 Series Sliding Door Installation Instructions

TOOL LIST

- Knife
- 4' Level
- Hammer
- Chalk Line
- Wire Ties
- Wire Cutter
- Multi-Meter
- 4' or 6' Ladder
- Hammer Drill
- Tape Measure
- Electrical Tape
- Extension Cord
- 3/8" Cordless Drill
- Vise Grip Pliers
- Channel Lock Pliers
- Caulking & Gun
- Shim Material (shingles)
- Flat & Rat tail files
- Combination wrench set (standard & metric)
- Screwdrivers (#2 & #3 Philips, Sm. & Med.)
- Allen Hex wrench set (standard & metric)
- Ratchet & Socket set (standard & metric)
- Drill bit set up to 3/8" & 1/4" & 5/16" masonry bits

GENERAL REQUIREMENTS

- Power: 120VAC, 60Hz., 15 Amp Service to terminal block in aluminum head section of door. Wiring to be in conformance with local codes and routed away from moving parts.
- Non-North American voltages can be 240VAC, if so be sure the operator has a 240VAC power supply.
- Power may be brought in through the top of the jamb on perimeter mount units or in through the back of surface mount units.
- For remote switch locations, routing of low voltage wiring to the operator controls will be required and there locations should be predetermined and wired before installation begins.
- Door Panels may be glazed before or after installation.

POWER INPUT LOCATIONS

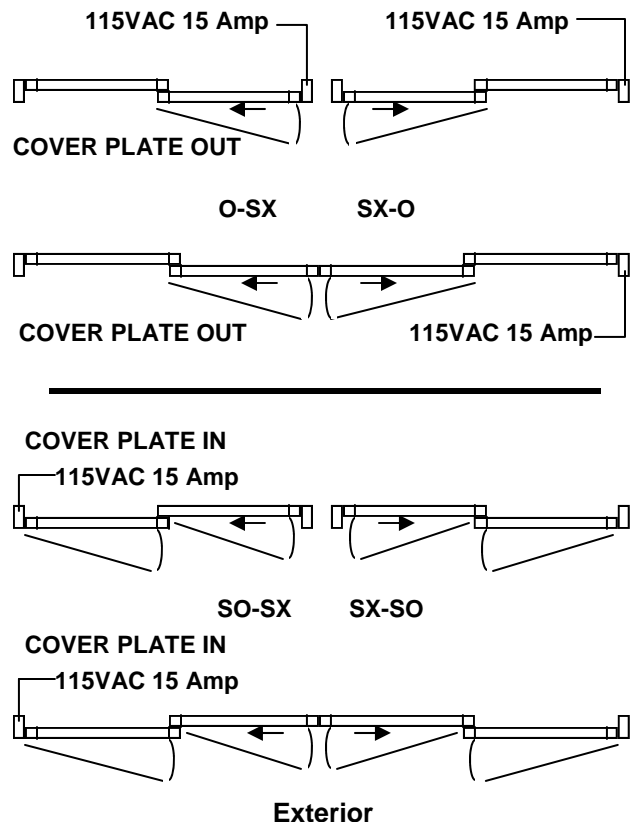



5100 Series Sliding Door Installation Instructions

PRODUCT INVENTORY AND PREPARATION

There are several different type packages built. Make sure the package you are installing meets the needs of the opening intended. (Inside slide, outside slide, or surface mount)

1. Once the material has been received inspect all cartons for completeness of order.

There should be at least six cartons for a standard bi-part package.

The following items should be present.

- A. Header Assembly (contains sensors and parts bag)
- B. Side Jambs (contains side jambs and transom)
- C. Door panels (contains vinyl)

2. Check the door opening for plumb and level. The floor must be checked for any high spots. The header can be used for the straight edge to detect any variation in the floor surface. Fill the low areas to make the floor level. See the **Figure 1** below for additional information.

3. Do not allow over 8' of unsupported header. (The fixed panel is considered as suitable support for the header.) If the unit is equipped with a transom, and the unit length is greater than 8', the frame of the existing structure must support the weight of the transom, glass, and an additional 130 lbs. for unit lengths up to 12', and 260lbs.for units up to 16'.

Lay out the frame components and transom (if equipped) on the floor along side the door opening. Be careful not to scratch the finish. Position the header so as to allow for lifting into the opening once all the components have been assembled.

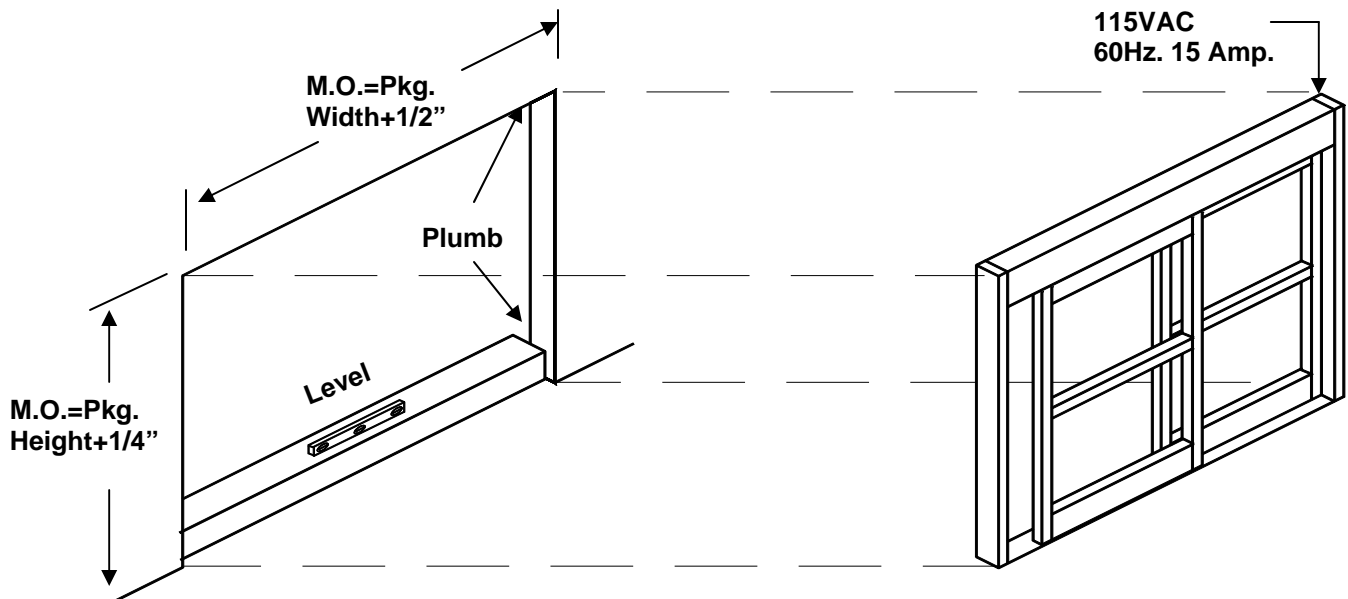

Figure 1

FRAME TO HEADER ASSEMBLY

Please find located in the header assembly, a small parts bag, the 1/4-20 x 1" Hex Head Bolts with 1/4" flat and 1/4" lock washers to attach side jambs to header through the end bracket as shown in Figure 2.

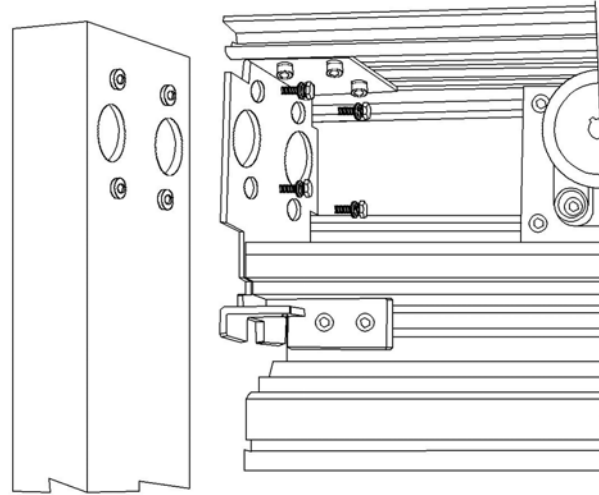

Figure 2

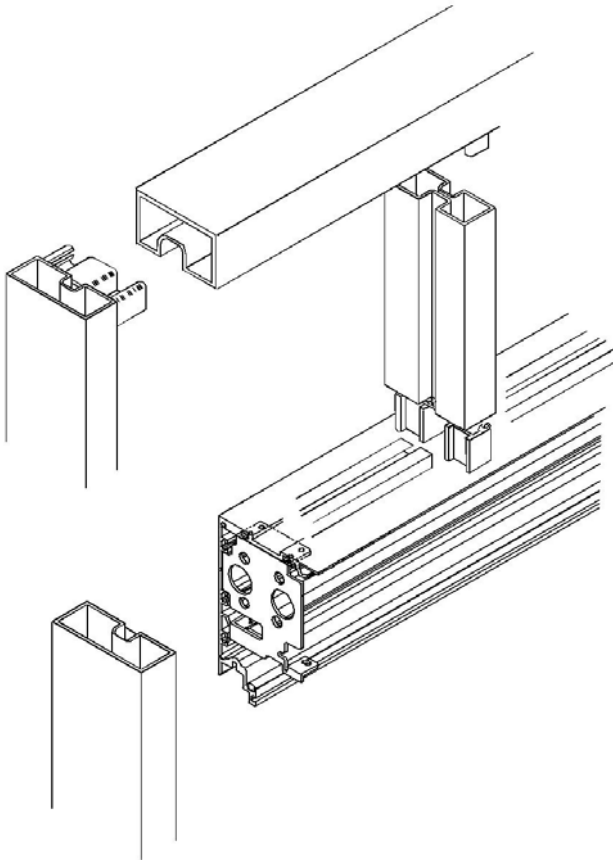
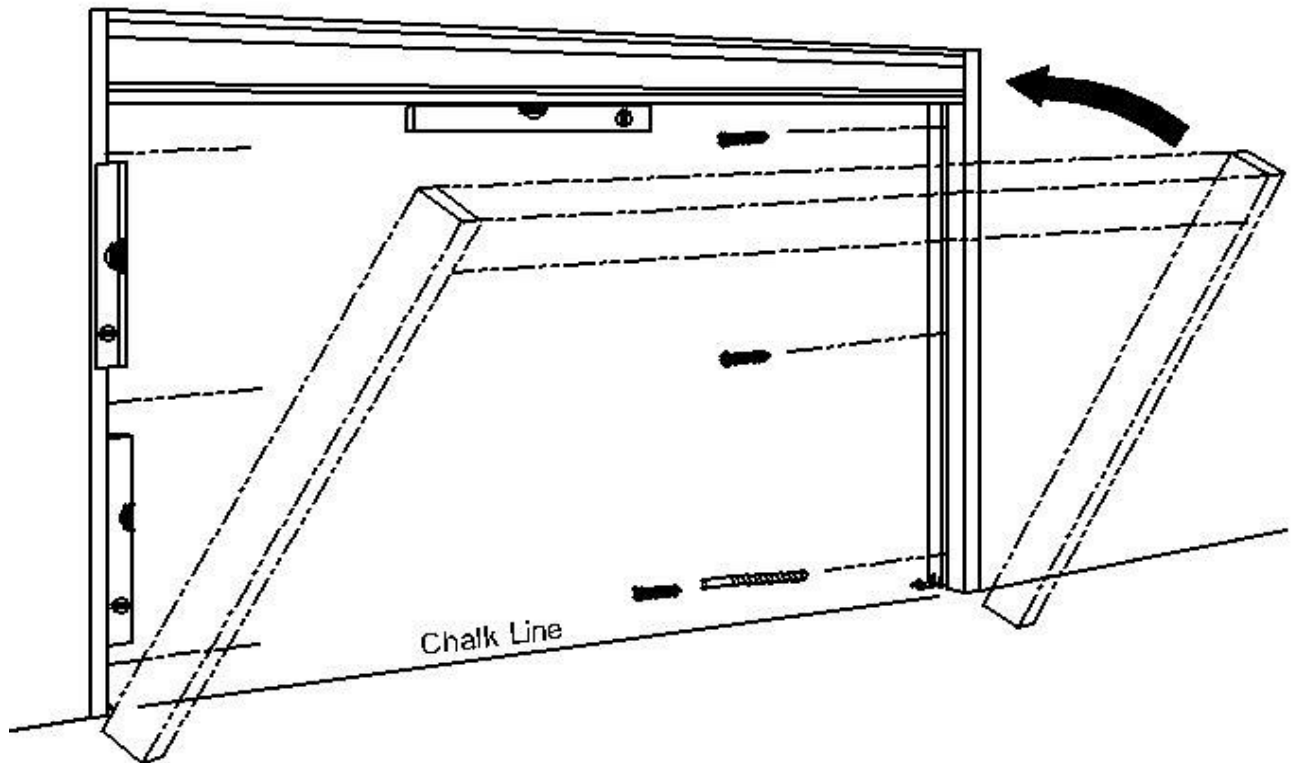

Figure 3

TRANSOM ASSEMBLY

If the unit is supplied with transom, see Figure 3 for view of assembly. It is suggested that the frame members be prepped for attachment and attach with a screw; suggested size 10-24 x 1/2" flat head machine or sheet metal thread.



SETTING FRAME

Once the door frame has been assembled, place the frame in front of the opening on the floor so that the bottom of the jambs are at the base of the opening. Snap a chalk line across the opening where the jamb line is going to be. This line will also locate the bottom guide system.

Before lifting the frame into place, check to make sure the cover side of the header will end up on the correct side of the opening. If the unit has sidelites that breakout, the cover will be interior; if the sidelites are fixed or the unit is surface mounted, the cover will be exterior.

Lift door frame into the opening and set the frame plumb and square to the highest spot on the floor and position the frame within the 4-1/2" dimension as needed. If the high spot or swell in the floor forces the frame to go higher than the rough opening will allow, Do Not install the frame. Door height adjustment will be reduced if the frame is installed with this condition present. Have the contractor rework the floor so the doors can be properly installed.

If there is room to raise the frame up even with the high spot in the floor, shim the bottom of the jambs to the high spot.

FRAME ATTACHMENT

Using wood shims, plumb and square the header and jambs in the opening. Fasten the door frame to the opening with the appropriate type and number of fasteners for the size of the door package being installed. Fasten the header overhead every 36" or less.

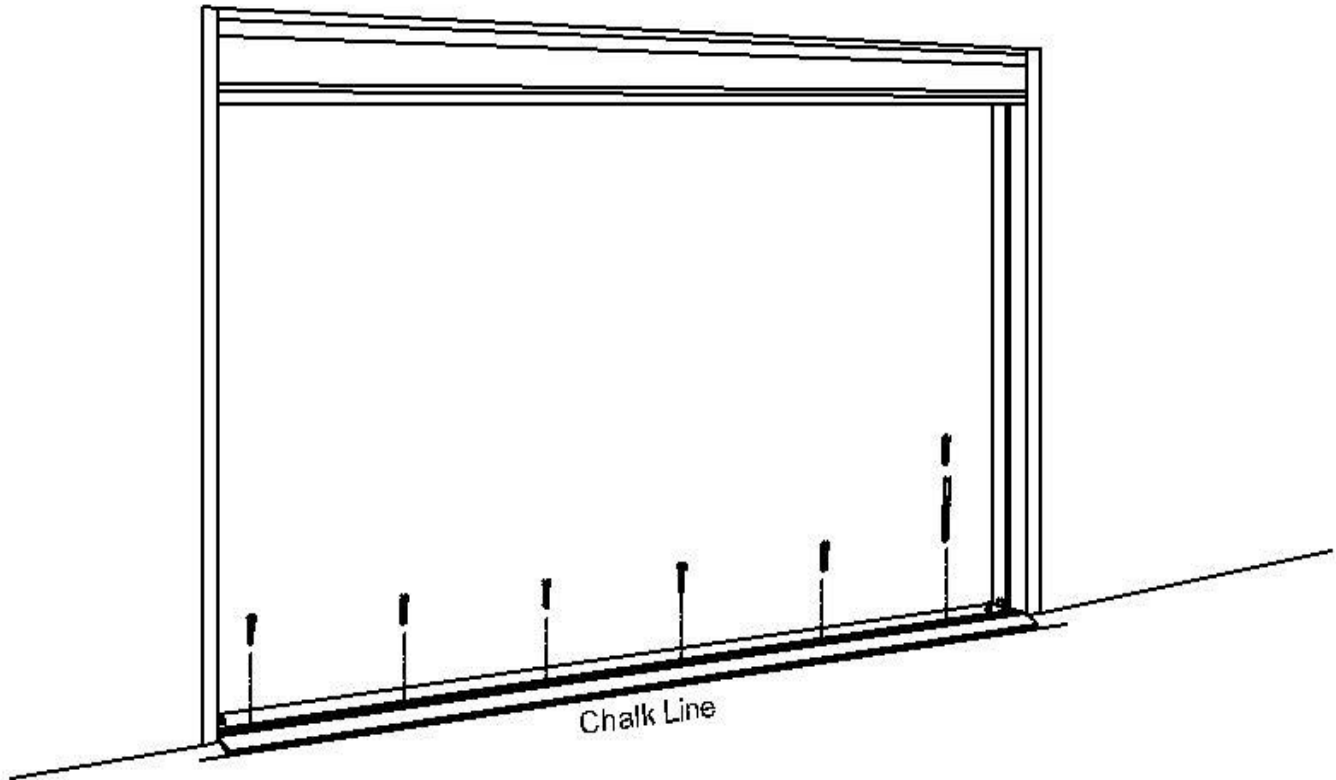

BOTTOM GUIDE INSTALLATION

The bottom guide rails or track must be installed level and in line with the frame for the door package to properly function. If the high spots referred to on page 6 were not corrected as indicated, proper location of the guide rails will be extremely difficult. Correct high spots and continue.

Identify the type of guide system being used with the door package. The standard guide for a fixed panel unit (o-sx-sx-o) is a guide rail with or without threshold; for full breakout units (so-sx-sx-so), the standard bottom guide is a pin guide track which is the same with or without threshold.

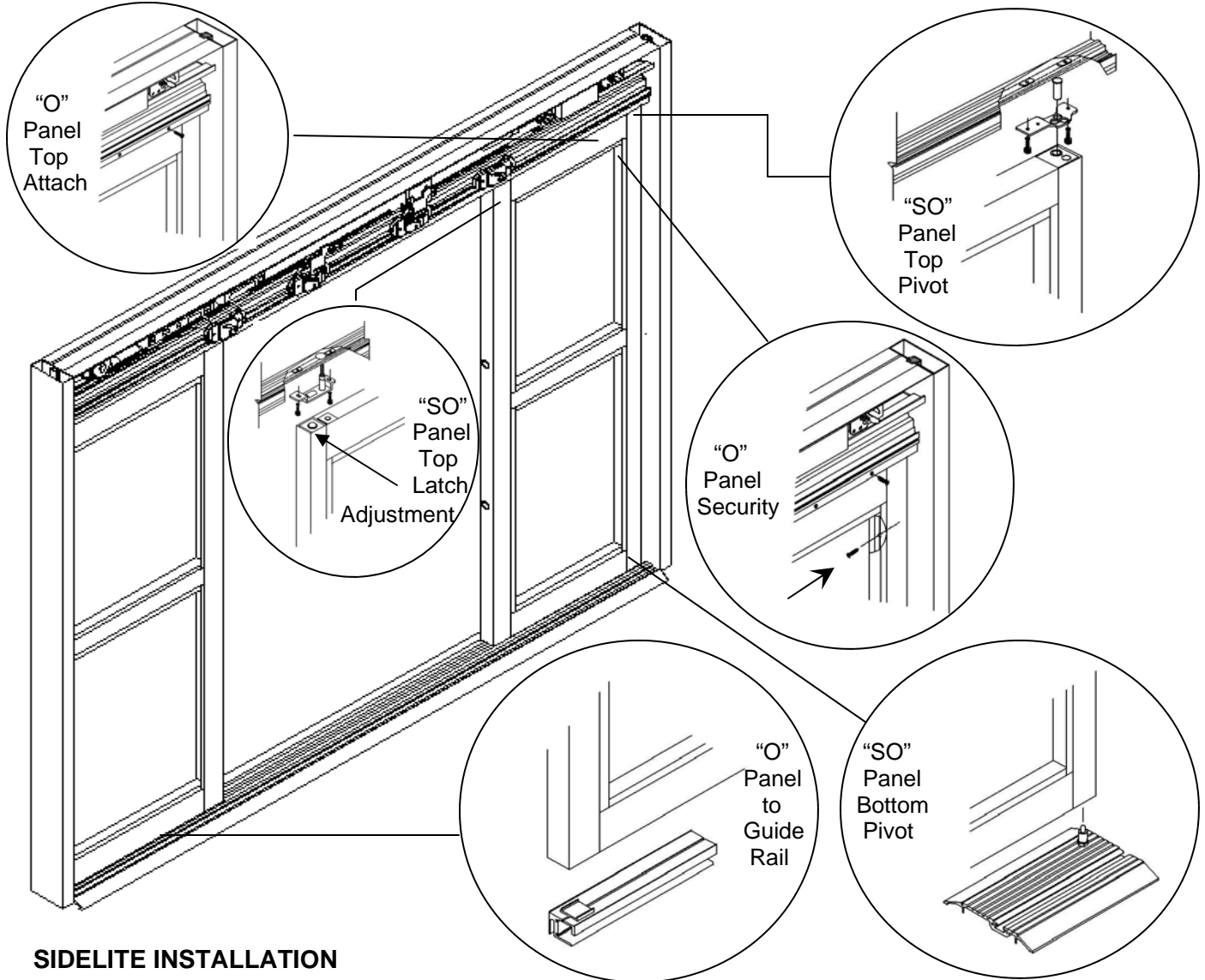

SIDELITE INSTALLATION

To install a full breakout sidelite that has a jamb or floor mounted bottom pivot, remove the top pivot bracket with clevis pin and install it in the top pivot angle of the sidelite. Proceed by feeding the safety beam wires through the third hole in the pivot bracket. Install the sidelite on the bottom pivot first, rotate the sidelite into the 90° open position and tilt the top toward the header, aligning the pivot bracket to its original position on the underside of the header and reinstall the screws while continuing to feed the wires inside the header. Push the sidelite into a vertical position with the top pivot against the jamb. Tighten the allenhead screws securing the top pivot in place. After the safety beam wires are completely fed into the header, connect to the matching connectors. Note the safety beams are pre-wired in the door panels, jambs, and header, with small connectors provided between each assembly. No additional wiring should be required. Refer to the included operator wiring diagram.

To install a fixed sidelite to the header, insure the bottom guide rail is set properly to the floor. Install the sidelite to the top of the guide rail. Secure the sidelite to the header with the #10 screws provided after feeding the safety beam wires into the header and making the connections. Additional screws can be installed through the vertical stile and into the jamb before the sidelite is glazed for full security on a fixed panel unit as shown above.

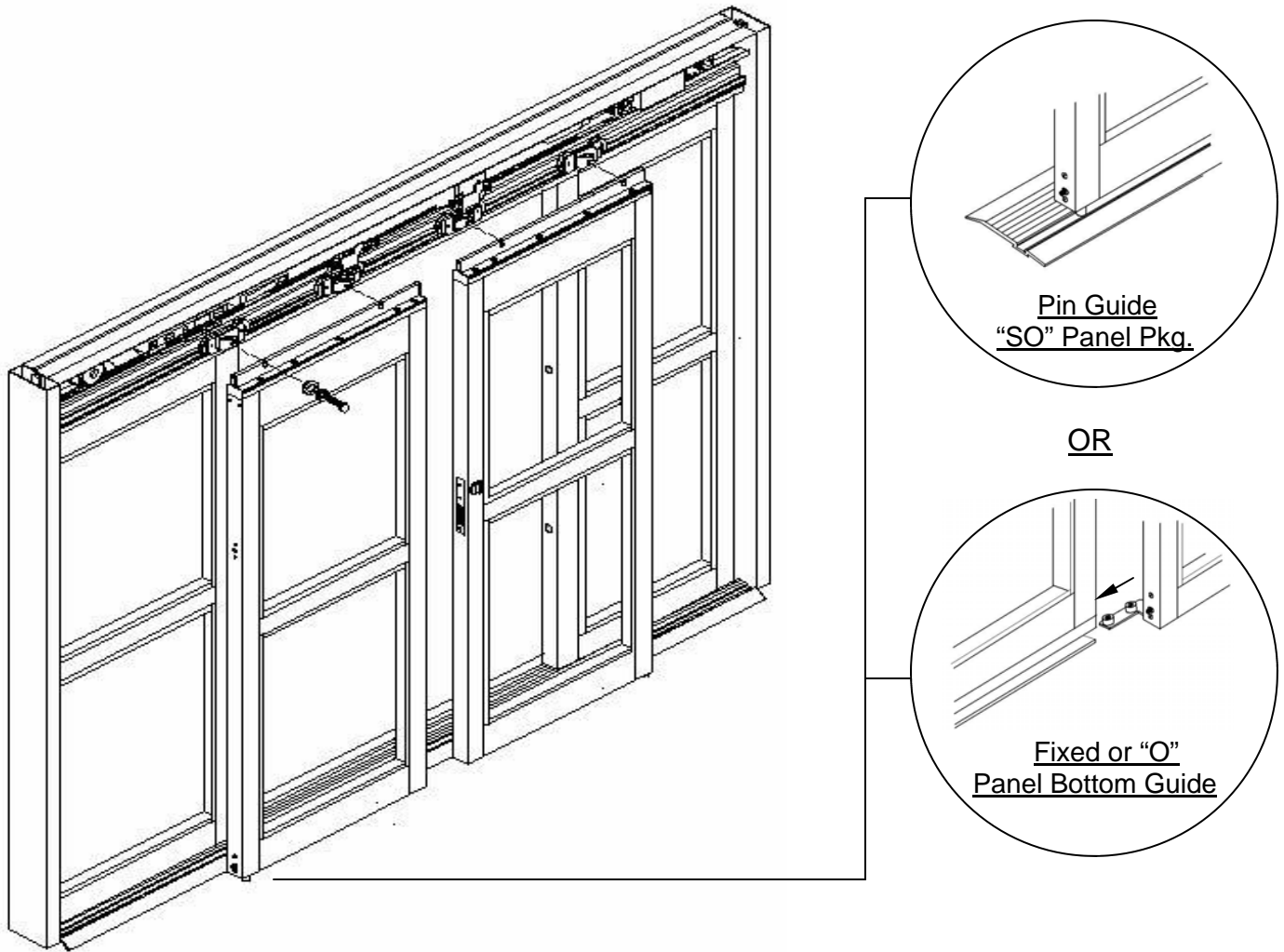

SLIDING DOOR INSTALLATION

Position the door so that it will panic to the exterior of the building when broken out.

Install the door portion of the bottom guide in the pivot stile of the door using four 10-32 screws provided, and one ¼-20 set screw to lock guide pin at proper height.

Position the door portion of the bottom guide into the guide rail or the pin guide track (depending on the type bottom guide used).

Place the door so that the slots in the hanger catch rail are lined up with the 5/16" tapped holes in the door carrier brackets. Thread the two 5/16"-18 x 1-1/4" hardened hex head hanger bolts with the flat washer and split washer through the slots into the door carriers. Tighten the hanger bolts until the door does not sag, but do not tighten all the way.

Adjust the door height (floor clearance) by adjusting the 1/4-20 hex head bolts above the slots in the top catch rail.

Once proper height has been adjusted insure there are no gaps between doors or door and jamb from top to bottom. It may be necessary to readjust height adjustment screws.

Complete by tightening the hanger bolts.



5100 Series Sliding Door Installation Instructions

CAUTION: Do not install the Control Panel Display Module in the Side Jamb until all drilling and frame attachment is accomplished to prevent metal shavings from dropping in the electronics of the module.

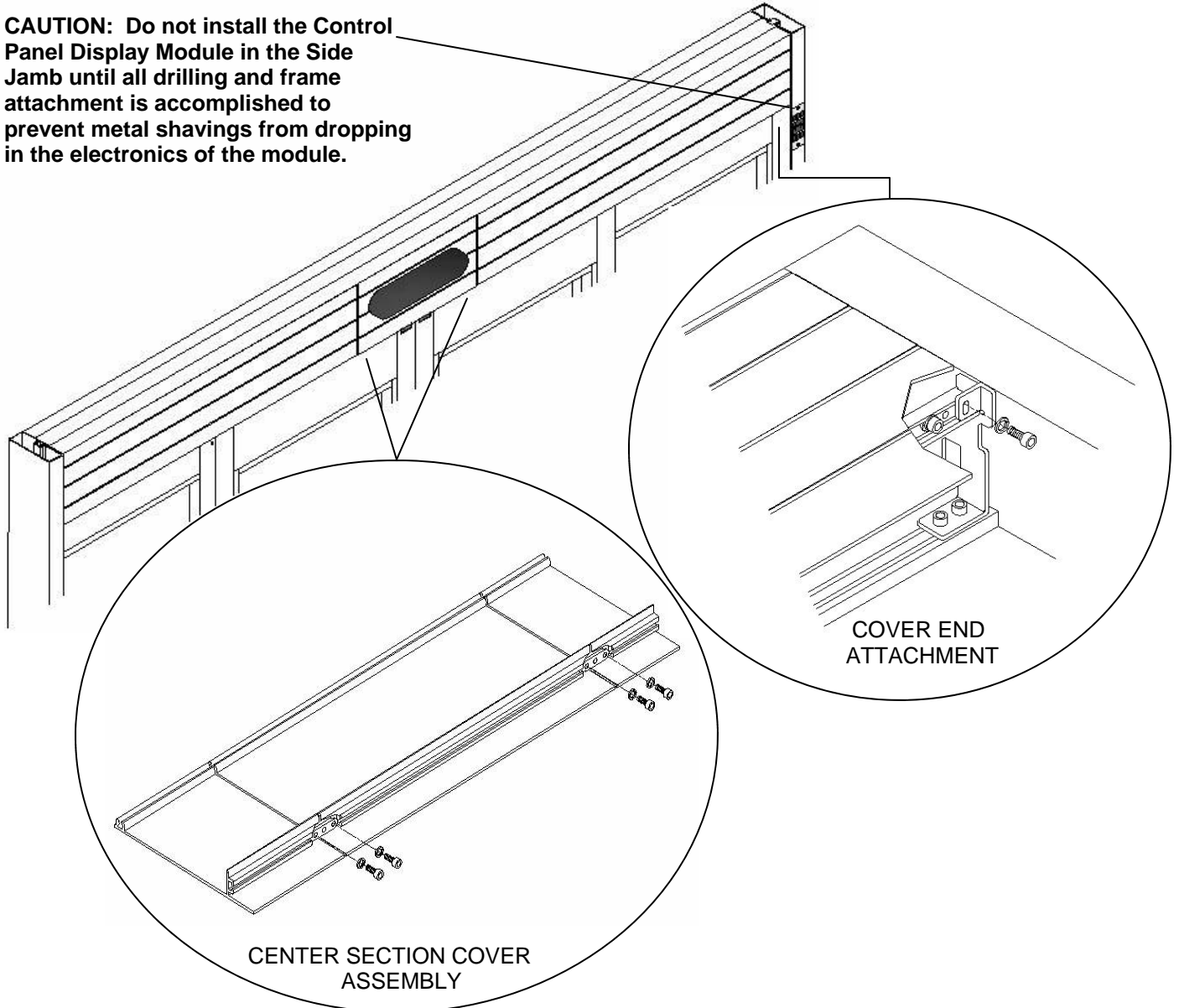

ACCESS COVER ATTACHMENT

If the unit is a bi-part, there will be a short center section that will be held in alignment to the RH and LH covers with two nut plates and four 10-32 Allen cap screws with washers. To remove RH or LH cover, loosen the screws and slide the nut plates with screws to the center section, allowing removal. At either end of the unit, please find a 10-32 Allen cap screw with washer to remove completely, for it attaches through the header to jamb bracket. (See views above)

WIRING THE DOOR

This product is intended for permanent connection to the electrical supply system. Proper grounding must be provided and wiring must conform to applicable codes. 24VDC, 1 Amp power is available for external devices (sensors). Refer to the instructions provided with the sensors and the enclosed wiring diagram. Safety beam cable routing is covered in the sidelite installation section; connections are shown on the wiring diagram. The Display Control Panel wiring is covered on Page 12.

COMMISSIONING THE DOOR

Refer to the enclosed instructions for commissioning.

To increase the “lift” of the breakout mechanism and prevent the door from dropping when broken out, perform the following instructions:

1. Insure the glass is blocked properly and in the locations shown at right. Please see location of Glass Jacking Screw to adjust and aid in blocking and preventing the door from dropping when “SX” Panel is in breakout.
2. Breakout the “SX” Panel 6”-8” as shown.
3. Using a 5/32” Allen hex wrench, loosen the two 1/4-20 Button Head socket cap screws located on the back of the vertical pivot stile 18” from the top.
4. Insert a 3/16” Allen hex wrench in the center hole between the two screws and tighten the concealed cap screw clockwise until snug.
5. Using your foot, apply force to the pivot stile below the screws in the direction of the lock stile, lifting the lock stile and the front of the panel.
6. Place a shim/wedge under the lock stile to remain elevated & re-tighten the two 1/4-20 Button Head screws. **Note:** Do not over tighten as this may cause distortion in the aluminum stile.
7. Remove shim/wedge and check for adequate lift support.

To adjust the force required to initiate a breakout, locate the ball catch at the top of the vertical lock stile and rotate it counterclockwise to increase the force required.

STEP 5

APPLY
FORCE

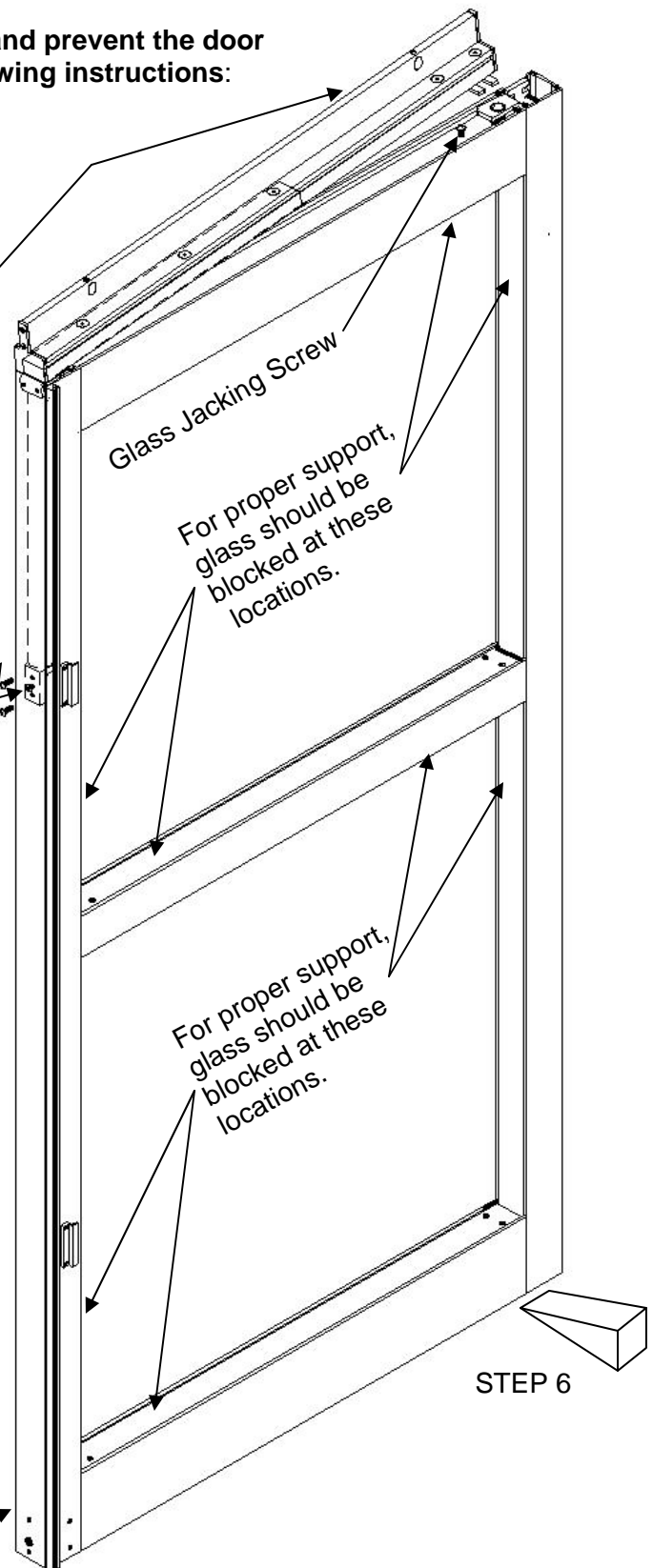

STEP 6

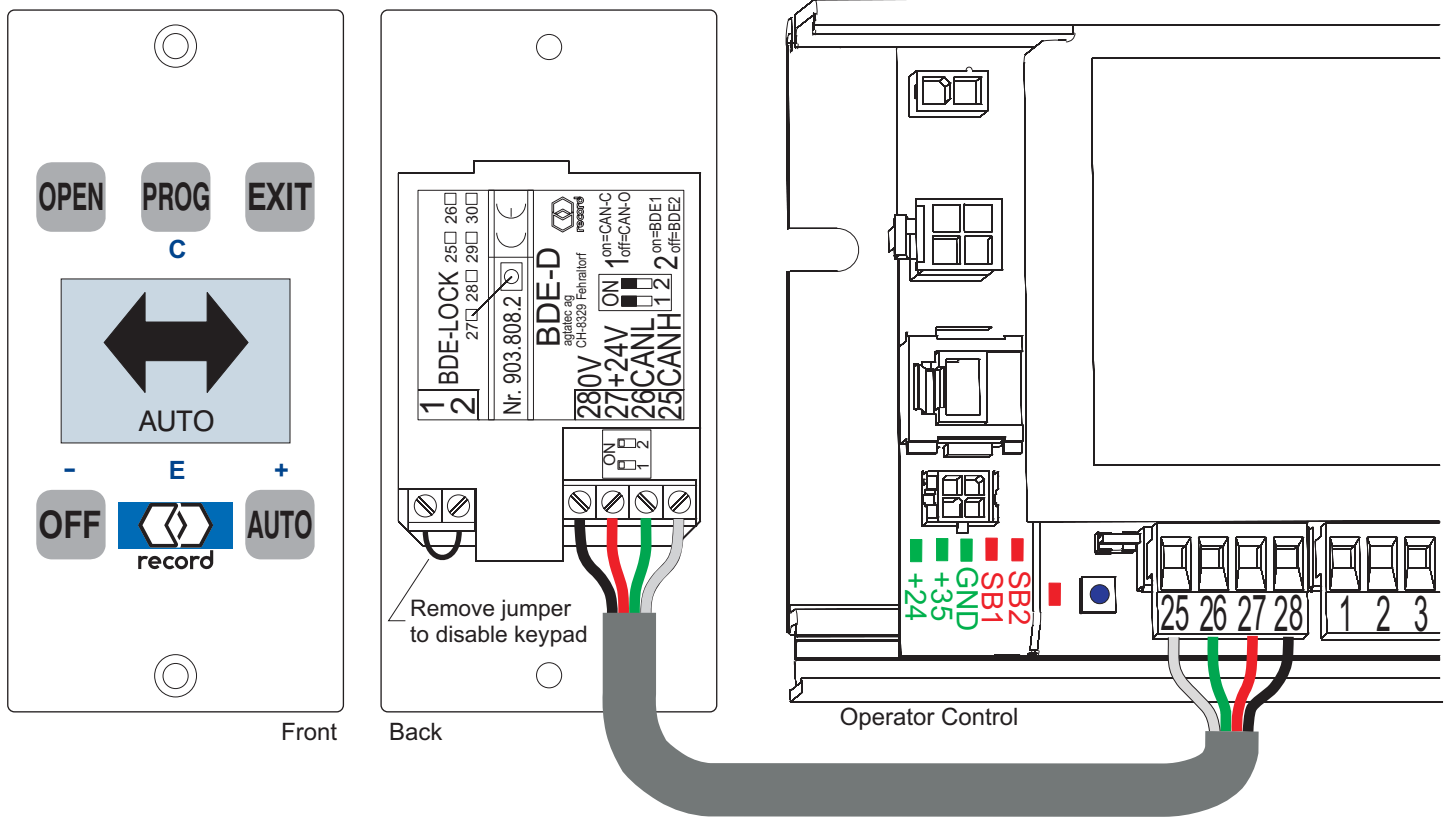

The Display Panel Control is connected to the Series 5100 Operator Control as shown and is typically mounted in the door jamb adjacent to the sidelite. The unit may be remotely mounted as desired, and should always be in a location where the user can view the door. An optional enclosure is available for remote mounting (see image below right).

The keypad on the display can be disabled by removing the jumper located between screw terminals 1 & 2 on the back of the display (see above). A switch (SPST) can be wired in place of the jumper and provide remote enable/disable of the keypad.

When the keypad is disabled, a small key is displayed on the left of the screen. The unit will continue to display the current operating mode of the door and will exhibit any alarm condition as it occurs, but the keypad will not function.

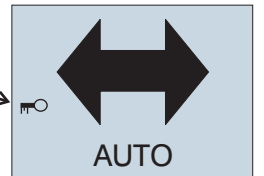

Two Display Control Panels can be connected to a Series 5100 for mode control from two separate locations. The panels are wired in parallel, and Dipswitch #2 (above wire terminals 26 & 27) on one panel should be set to "OFF". Two mechanical switch assemblies (shown at right) are available for connection to a Series 5100 in addition to the Display Control Panel. The mounting template is identical to the display panel; these units can replace the display on the door. Refer to the Series 5100 Wiring Diagram for wiring. Note: When a mechanical panel is connected, it will have priority over the display panel when selecting operating mode.

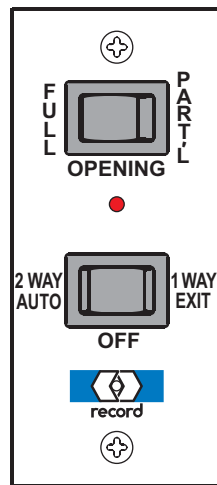

4-51-0105

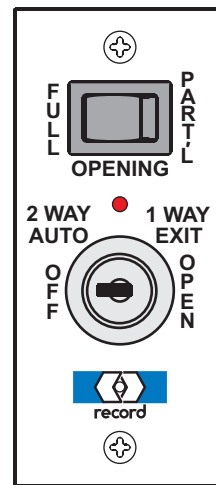

4-51-0106



Optional Enclosure

Commissioning the Series 5100 using the Display Control Panel

The Display Control Panel is a convenient input and output unit for the door system and programming of control units in record door openers. Logically arranged pushbuttons permit an intuitive operation of the door and navigation through the drive-specific menu structure. The backlit LCD display provides data and information regarding the status of the door using symbols and plain text messages. The connection to the door control is via the CAN bus built into the record products.

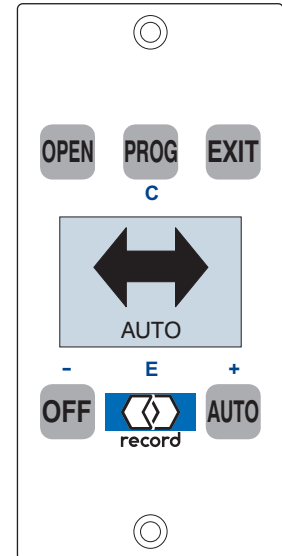

The technical specifications of the control panel are:

Supply voltage: 24 VDC from CAN bus
 Connected load: < 2 W
 Dimensions: 1.74" X 3.63"
 Temperature range: 0°C to +50°C
 LCD display: 112 x 64 pixels (0.84" X 1.18"), with white backlight

In addition to providing the owner a method for selecting the door operating modes, the control panel can be used to access and adjust the door parameters. To enable this feature, first gain access to the door operator in the header, and locate the microprocessor control. On the lower left of the control are three green LEDs, 3 red LEDs, and a small pushbutton (Control Switch Button). The pushbutton performs multiple functions depending upon how long it is pressed, as indicated by the adjacent red LED.

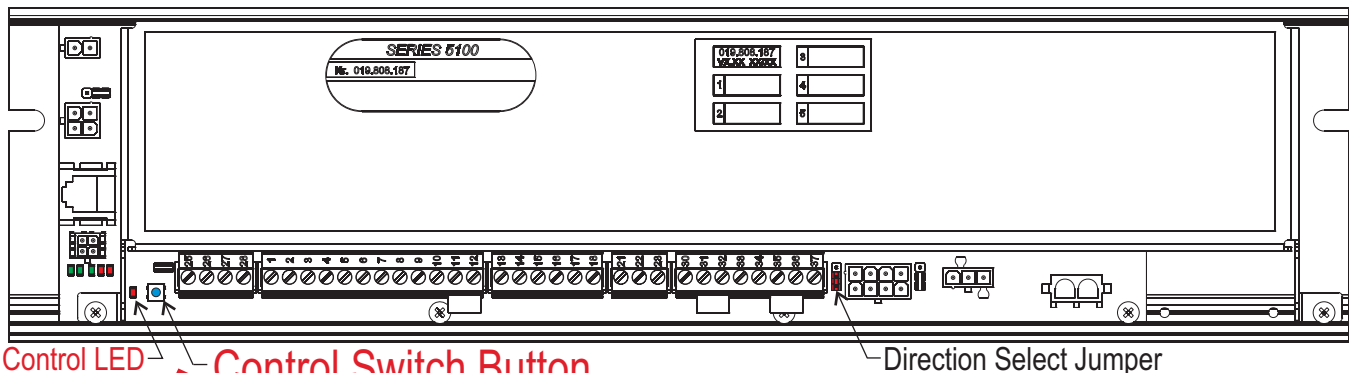

- Pressing and holding the button causes the adjacent red Control LED to pulse "on" approximately once per second. The number of pulses determines the resulting effect:
- 1 pulse simulates the actuation of the interior sensor and initiates a door cycle.
 - 2 pulses initiates an automatic acquisition of safety beam and battery characteristics.
 - 3 pulses initiates a door learn mode where the door weight and friction are learned.
 - 4 pulses initiates a configuration mode where the Display Control Panel has access to the microprocessor control parameters.
 - 8 pulses resets the microprocessor parameters to the factory defaults.
 - 12+ pulses performs a complete hardware reset.

Typically, during a new installation, the microprocessor will have already been set at the factory for the door opening, **but the completed installation will require a calibration mode initiated by holding the Control Switch Button down for three pulses of the Control LED. Calibration will occur during the next three door cycles, which should be initiated immediately.** If additional changes to the door operation are desired, then proceed to the next section.

Parameter Configurations

Press and hold the Control Switch button for 4 pulses of the adjacent red Control LED.
The Control Panel Display will change from current operator mode to configuration mode -

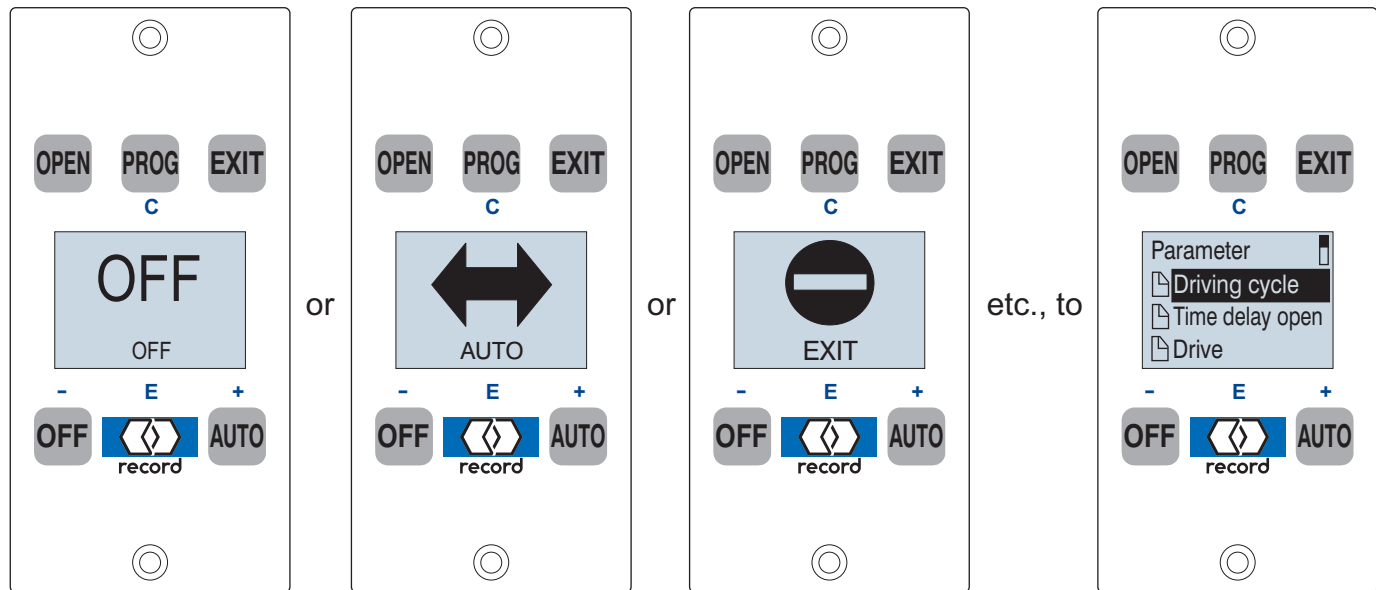

In this mode, the top center "PROG" switch and bottom three switches are used to select and modify the door parameters. Note the small blue legends next to each switch indicates its use in the configuration mode -

Use the "+" (AUTO) switch to scroll down menus, or increase individual parameter values.

Use the "-" (OFF) switch to scroll up menus, or decrease parameter values.

Use the "E" (record) switch to select the currently selected parameter or parameter value.

Use the "C" (PROG) switch to revert to the previous screen.

The various parameters are distributed in menus and sub-menus in the following order:

Driving Cycle -

Closing Speed (12 inches per sec. max.)

Opening Speed

Acceleration

Time Delay Open - 60 seconds maximum

TD Open (for sensor actuation)

TD Remote Switch

Drive -

Partial Open - 8 in. minimum

Reverse Adjust - More sensitive (default) or Less sensitive

Emergency Open / Close - normally disabled

Power Failure - optional for battery backup

Entrance System -

Door Type (always select Breakout-USA)

Control Panel -

Mechanical Panel (typically disabled), and Display Panel

Note several options are available for the Display Panel -

Language (English US), Keyboard (Off), Contrast, and Time Delay - Backlite (seconds)
(TD Backlite=0 turns off the backlight; TD Backlite=40 is always on)

Locking -

Locking Function - Manual, Night locked, 1-Way locked, Always locked

Lock Type - Without lock, Motor powered, BiStable, MPU, Magnet,

Fail Secure, and Fail Safe (North American options underlined)

Input -

Exterior Switch Input - always select "Ext. Sw IN" (as required by ANSI A156.10)

Emergency Open / Close - typically disabled

Auxiliary Switch - disabled, Safety Beam (other than builtin unit), Sidescreen Sensor,
CO48 (North American options underlined)

Output -

Alarm - will actuate auxiliary relay contacts when an alarm mode occurs



Gong - will actuate auxiliary relay contacts when safety beam is interrupted

Miscellaneous -

TOWA - If door is in Partial Open mode and traffic occurs in both directions,
or occurs for more than 10 seconds, door temporarily fully opens.

To exit the parameter adjust mode, press the "C" (PROG) multiple times until the "Exit Program Mode - NO / YES" screen appears, then press the "E" record switch to exit.





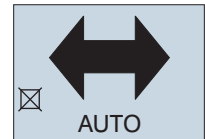









Note; If no switch is pressed for 3 minutes, the Program mode is automatically exited.

The control panel can be "locked", preventing unauthorized use, by pressing the key sequence -  +  +  A small square with an "X" will appear on the left of the display. To re-enable the keypad, repeat the above sequence.



Entering a custom telephone number for the error screens is accessible only through using an FPC902 Flash Programmer / Hand Terminal. See its instructions for further details.

The following are examples of Alarm screens that may appear, indicating an abnormal door status:

 63 Obstruction	The door has encountered an obstruction, either in opening or closing, which requires more power than allowed by code.	 14 Alok Mon. Sw VAK fault	The monitor switch on the automatic lock is providing a signal which does not correlate with expected lock status. Also check wiring to switch.
 31 EMERGENCY STOP/BREAKOUT	One of the door panels has been broken out, and not fully reset into its closed position. Also check for a damaged panel cutoff switch.	 10 Locking error	The automatic lock is not properly engaging and locking the sliding motion of the door. Check mechanical alignment.
 59 Safety Beam ELS active>60s	One or more of the safety beams has been obstructed for more than 60 seconds. Also check for damaged wiring to beam heads.	 6 Unlocking error	The automatic lock is not unlocking and releasing the door to slide open. Check mechanical alignment.
 5 Exterior Sensor AKA active>60s	The sensor / switch connected to terminals 2 & 3 has been actuated for more the 60 seconds. Also check wiring for damage.	 43 Encoder fault	The signals from the encoder on the motordrive do not correlate with operator drive mode. Check wiring & connectors between motor & control.
 3 Interior Sensor AKI active>60s	The sensor / switch connected to terminals 22 & 23 has been actuated for more than 60 seconds. Also check wiring for damage.	 62 Control panel can't override	A second mechanical control panel or a remote control station has been connected and has priority over the Display control panel.
 61 Remote Sw. SSK active>60s	The sensor / switch connected to terminals 13 & 14 has been actuated for more than 60 seconds. Also check wiring for damage.	 2 Manual locked	The door has been locked from a remote control station and the Display control panel cannot override.
 47 Aux. Sensor SHE active>60s	The sensor / switch connected to terminals 5 & 6 has been actuated for more than 60 seconds. Also check wiring for damage.	 37 Motor current	The motor current is outside of allowable values (too low or too high) and the control has ceased automatic operation.



Series 5100 – Remote Control of Door Operating Mode

Enter the *parameter adjust* mode at the operator control module and, using the Display control panel, scroll down to and select the “**Control Panel**” parameter. Select “**Mech. Panel**”, scroll down to and select “**One-way**” (factory default is “**disabled**”). Exit *parameter adjust* mode. The *door operational* mode will now be “**Off**” until a jumper is placed between terminals 15 and 16 on the operator control module.

Remote Control of Automatic / Exit Only modes only –

A single set of dry contacts (rated 0.2A minimum) is required and connected between terminals 15 and 17 on the operator control module. When the contact is open, the door will be in “**Automatic**” mode; when the contact is closed, the door will be in “**Exit**” only mode, and the exterior sensor (connected to terminal 3) is disabled when the door is fully closed. As required by code, the exterior sensor will be active when the door is open and/or closing.

Remote Control of Automatic / Exit Only / Open / Off (or Locked) modes –

Two sets of dry contacts are required. One set will be connected between 15 and 17 as above, and the second set will replace the jumper between 15 and 16. The following table lists the *door operational* mode as defined by the contacts:

	<u>Mode</u>	<u>Contact 15/16</u>	<u>Contact 15/17</u>
	Off	Open	Open
Automatic		Closed	Open
Exit	Only	Closed	Closed
Full	Open	Open	Closed

If the door has a Fail Secure automatic lock, the door will be locked when in the “**Off**” mode.

If the door has a Fail Safe automatic lock, the door will not be locked in the “**Off**” mode. This can be changed from “**Off**” to “**Lock**” (locking the Fail Safe lock) by changing an additional parameter. Enter the *parameter adjust* mode at the operator control module and, using the Display control panel, scroll down to and select the “**Control Panel**” parameter. Scroll down to and select the “**Display Panel**”, then scroll down and select “**Keyboard**”. Change the setting from “**OFF-Mode**” to “**Locked-Mode**”. Exit the *parameter adjust* mode. “**Off**” will now be replaced with “**Lock**” when the *Off* button is pressed, or when the above contacts are opened. When using “**Lock**” mode in place of “**Off**” mode, when the *Off* button is pressed (or the above contacts opened), the door, if not closed, will always drive closed then lock. This is also true if using “**Lock**” mode with a Fail Secure automatic lock.

Note: Priority between the remote contacts and the Display control panel follows a safety / security tier. If either is *Off* (or *Locked*), the door will be “**Off**” (“**Lock**”). If the remote contacts are set for *Automatic* mode, the Display control panel has full functionality. If the remote contacts are set for *Exit Only*, only the Display’s *Off* and *Exit* buttons function. If the remote contacts are set for *Open*, only the Display’s *Off*, *Exit*, and *Open* buttons function.

Press and hold the blue Control Switch for 4 flashes of the red Control LED, then release. The first screen at right should appear on the jamb-mounted Display Control Panel. Scroll down to and select "Input", then scroll down and select "Aux. Sw", then scroll down and select "Safety Beam". Connect the safety sensors as shown below.

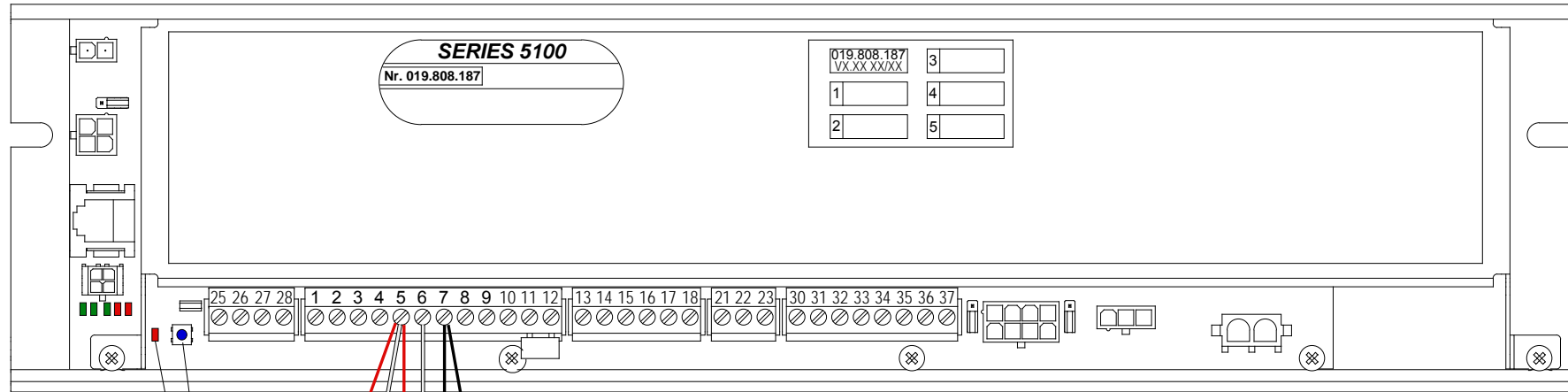
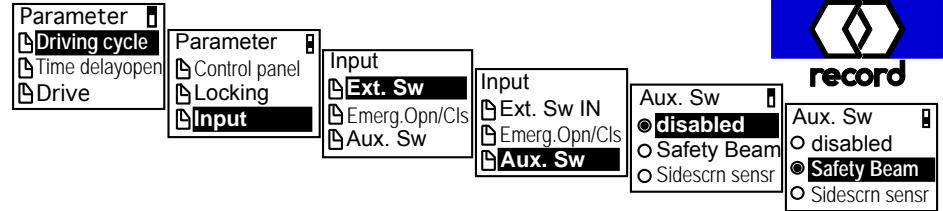

Control LED
Control Switch

PLEASE REFER TO PAGE 25 FOR STANDARD WIRING DIAGRAM

Safety Sensor #1

Safety Sensor #2

Control Term.#	Description	Sensor Connections	BEA IRIS	BEA Wizard	MS Sedco DH94 & DH100	Optex OA-Presence & i-One
#5	Power Supply +24V	+24V Power #1 & #2, Relay#1 COM	Red#1, Brn#1, Red#2	Red#1, Wht#1, Red#2	Red#1, Wht#1, Red#2	Gry#1, Wht#1, Gry#2
#6	Aux. Sensor Input	Relay#2 COM	Brn#2	Wht#2	Wht#2	Wht#2
#7	Power Supply - 0V	0V Power #1 & #2	Blk#1, Blk#2	Blk#1, Blk#2	Blk#1, Blk#2	Gry#1, Gry#2
Additional Connections		Relay#1 NC to Relay #2 NC	Relay#1 NC to Relay #2 NC	Relay#1 NC to Relay #2 NC	Relay#1 NC to Relay #2 NC	Relay#1 NC to Relay #2 NC
			Set Parameter $\bullet \rightarrow \bullet = 3$	Set Parameter $\bullet \rightarrow \bullet = 3$		
			Set Parameter F1 = 1	Set Parameter F1 = 1		

Series 5100 Wiring with 2 Safety Sensors
to be active only when door is open



Press and hold the blue Control Switch for 4 flashes of the red Control LED, then release. The first screen at right should appear on the jamb-mounted Display Control Panel. Scroll down to and select "Input", then scroll down and select "Aux. Sw", then scroll down and select "Safety Beam". Connect the safety sensor as shown below.

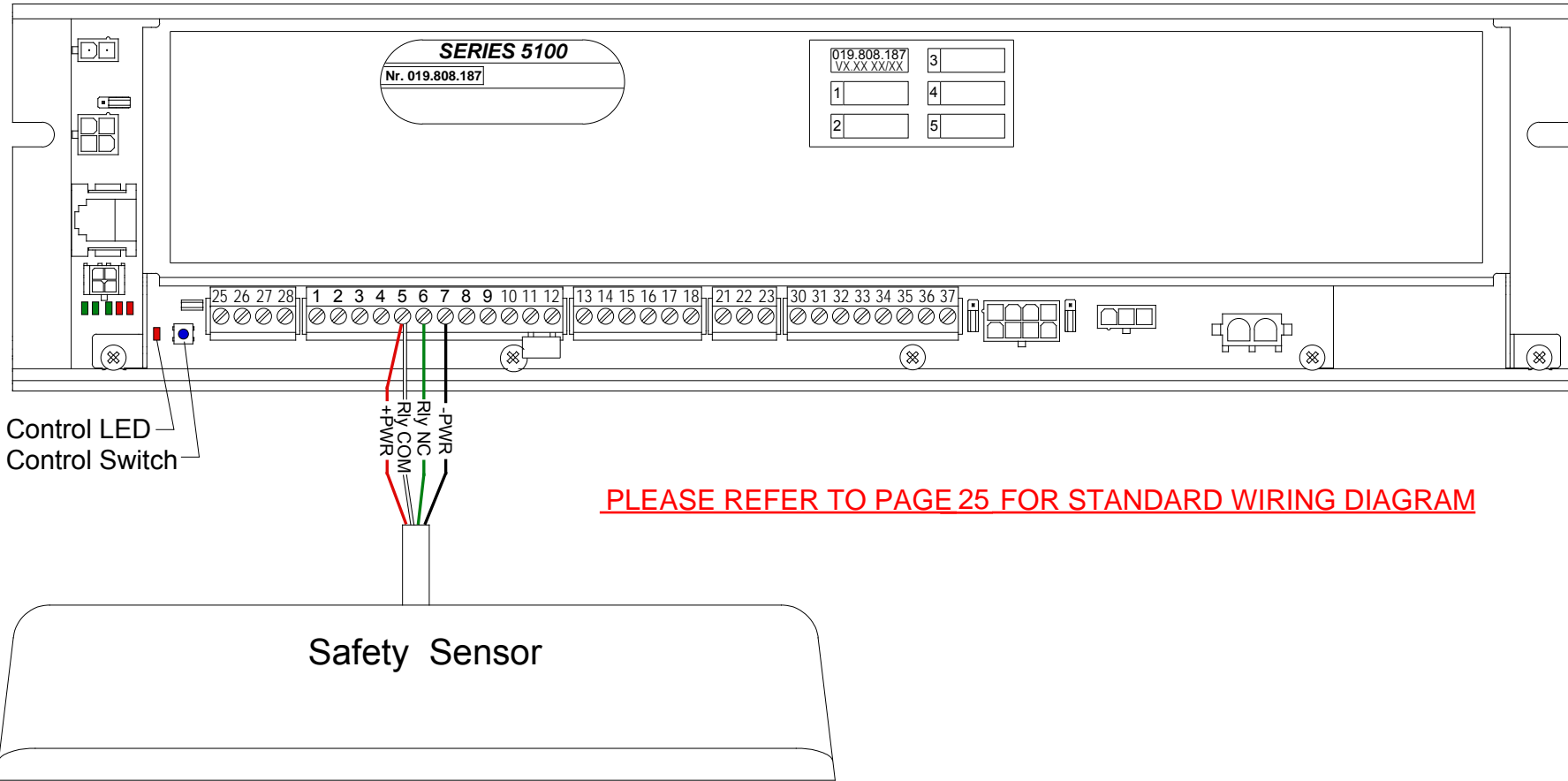
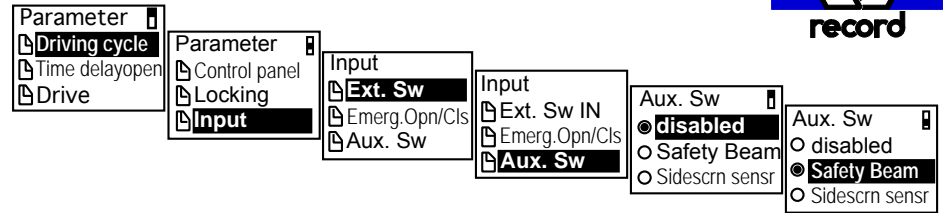

PLEASE REFER TO PAGE 25 FOR STANDARD WIRING DIAGRAM

Control Term.#	Description	Sensor Connections	BEA IRIS	BEA Wizard	MS Sedco DH94 & DH100	Optex OA-Presence & i-One
#5	Power Supply +24V	+24V Power & Relay COM	Red & Brn	Red & Wht	Red & Wht	Gry & Wht
#6	Aux. Sensor Input	Relay NC	Blu	Grn	Grn	Grn
#7	Power Supply - 0V	0V Power	Blk	Blk	Blk	Gry
			Set Parameter $\bullet \rightarrow \bullet = 3$	Set Parameter $\bullet \rightarrow \bullet = 3$		
			Set Parameter F1 = 1	Set Parameter F1 = 1		

Series 5100 Wiring with 1 Safety Sensor
to be active only when door is open

Oct06 DPH

PARAMETER ADJUST SCREENS

Parameter adjustment is accessed by pressing & holding the control switch on the operator control thru 4 flashes of the adjacent red control LED. Certain parameters have additional options not shown - these do not apply to North American applications and should not be selected.

Parameter Driving cycle Time delay open Drive	Driving cycle Closing speed Opening speed Acceleration Closing speed Opening speed Acceleration	Driving cycle Closing speed Opening speed Acceleration Closing speed Opening speed Acceleration	Driving cycle Closing speed Opening speed Acceleration Closing speed Opening speed Acceleration
Parameter Driving cycle Time delay open Drive	Time delay open TD open TD Remote Sw TD open TD Remote Sw	Time delay open TD open TD Remote Sw TD open TD Remote Sw	
Parameter Driving cycle Time delay open Drive	Drive Partial opening Reverse adjust EmergOpBattery Partial opening Reverse adjust EmergOp Battery	Drive Partial opening Reverse adjust EmergOpBattery Reverse adjust Less sensitive More sensitive	Drive Reverse adjust EmergOpBattery Power failure Reverse adjust Emerg. operation Power failure Battery operation Emerg. operation
Parameter Time delay open Drive Entrance system	Entrance system Door type Basic operator CO48 Ventouse CO48 Sandow dir	Door type CO48 Sandow d Basic escape rou Break-out USA	Door type Basic escape rou Break-out USA Ratchet
Parameter Drive Entrance system Control panel	Control panel Mech. Panel Display Panel Mech. Panel Display Panel	Control panel Mech. Panel Display Panel Display Panel Language Keyboard Contrast	Display Panel Language Keyboard Contrast Display Panel Language Keyboard Contrast Display Panel Language Keyboard Contrast TD Backlite
Parameter Drive Entrance system Control panel	Mech. Panel disabled Rkr &/or keysw One-way Mech. Panel disabled Rkr &/or keysw One-way	Language FRANCAIS ENGLISH ENGLISH US	Keyboard Locked-Mode OFF-Mode Contrast TD Backlite

Parameter Entrance system Control panel Locking	Locking Lock function Lock type Lock function Manual mode Night locked 1Way locked Lock function Manual mode Night locked 1Way locked Lock function Night locked 1Way locked Always locked	Locking Lock function Lock type Lock type Without lock Motor powered Bistable Lock type Bistable MPV Magnet Lock type MPV Magnet Fail secure Lock type Magnet Fail secure Fail safe
Parameter Control panel Locking Input	Input Ext. Sw IN Emerg. Opn/Cls Aux. Sw Ext. Sw IN Inactive by 1way and locked Ext. Sw IN Ext. Sw IN Inactive by 1way and locked	Input Ext. Sw IN Emerg. Opn/Cls Aux. Sw Ext. Sw IN Inactive by 1way and locked Emerg. Opn/Cls disabled Emerg. Open Emerg. Close Aux. Sw disabled Safety Beam Sidescrn sensr Aux. Sw disabled Safety Beam Sidescrn sensr Aux. Sw disabled Safety Beam Sidescrn sensr
Parameter Locking Input Output	Output Alarm/Gong Alarm/Gong Alarm Gong	Emerg. Opn/Cls Manual Override Emerg. Open Emerg. Close Manual Override Emerg. Open Emerg. Close Locked Emerg. Opn/Cls Locked Emerg. Close Locked&RemSw
Parameter Input Output Miscellaneous	Miscellaneous TOWA Miscellaneous TOWA	

ALARM SCREENS

14 Alok Mon. Sw VAK fault	47 Aux. Sensor SHE active>60s	31 EMERGENCY STOP/BREAKOUT	43 Encoder fault	5 Exterior Sensor AKA active>60s
14 Alok Mon. Sw VAK fault	47 Aux. Sensor SHE active>60s	31 EMERGENCY STOP/BREAKOUT	43 Encoder fault	5 Exterior Sensor AKA active>60s
3 Interior Sensor AKI active>60s	10 Locking error	37 Motor current	63 Obstruction	61 Remote Sw. SSK active>60s
3 Interior Sensor AKI active>60s	10 Locking error	37 Motor current	63 Obstruction	61 Remote Sw. SSK active>60s
59 Safety Beam ELS active>60s	6 Unlocking error	62 Control panel can't override	REMINDER DAILY SAFETY CHECK	Software STA19US V1.40 BDE-D V1.14
59 Safety Beam ELS active>60s	6 Unlocking error	2 Manual locked	FOR SERVICE CALL 800-438-1937	3 Service point {XXXXXXXXXX}

USER SCREENS

OFF	AUTO	EXIT	OPEN	LOCK
OFF	AUTO PART'L	EXIT PART'L	OPEN PART'L	LOCK
OFF	AUTO	EXIT	OPEN	LOCK
OFF	AUTO	EXIT	OPEN	LOCK
Partial opening	REMINDER DAILY SAFETY CHECK	FOR SERVICE CALL 800-438-1937	3 Service point {XXXXXXXXXX}	record SERIES 5100 Display Panel Screens Dec06



Daily Safety Check located below control panel

Decals mounted between 36" & 60"

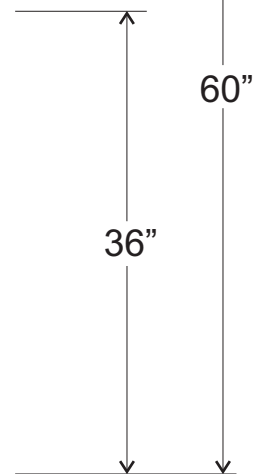

FOR "KNOWING ACT" DOORS, REPLACE



WITH



SAFETY DECAL REQUIREMENTS

Oct06

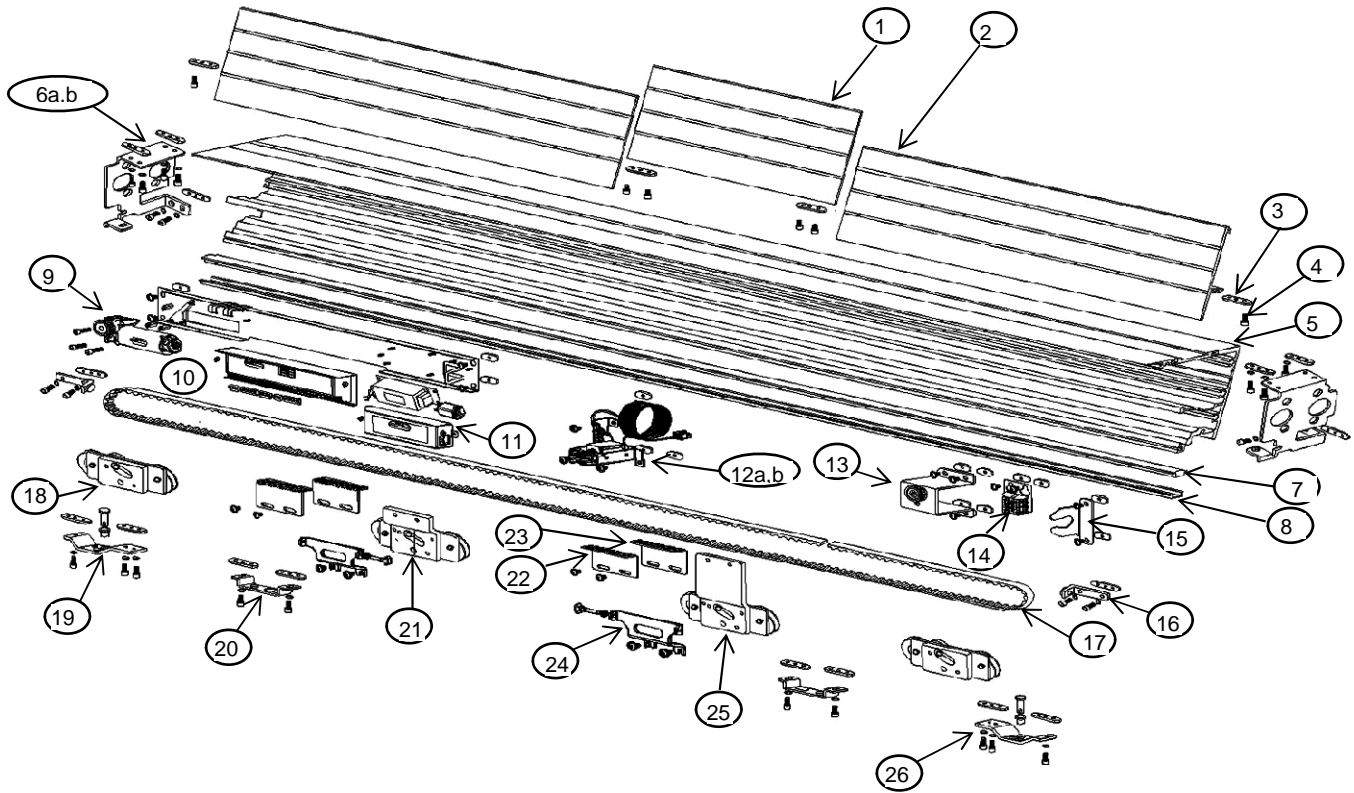

Item	Part Number	Description	Qty.	Item	Part Number	Description	Qty.
1	5-51-4002	Cover,Center,15",bipart	1	15	4-51-1004	Conduit Bracket	1
2	5-51-4002	Cover, CL-DB	~	16	4-51-0020	Assy, Door Stop	2
3	4-51-1037	Nut Plate, 10-32, 3 holes	20	17	9-09-0012	Belt, Timing, 5100	~
4	81-0016-2562	Screw, 10-32x1/2 Allen CS	12	18	4-51-0012	Carrier Assy, Slave	2
5	5-51-4001	Header, 5100, CL-DB	~	19	4-51-0007	Bracket Assy,Pvt-LH	1
6a	4-51-1055	Bracket,Header Mntg.-LH	1	20	4-51-0009	Bracket,Sidelite Strike	2
6b	4-51-1056	Bracket,Header Mntg.-RH	1	21	4-51-0003	Carrier Assy,Lower Belt	1
7	5-51-4004	Roller Track, 5100	~	22	4-51-1001	Bracket, Belt Base	1
8	9-51-0001	Damper, Roller Track	~	23	4-51-1002	Bracket, Belt Clasp	1
9	9-99-2154	Motordrive Assy, 5100	1	24	4-51-1045	Bracket,Lock Strike,Std	2
10	9-99-1322	Control Assy, 5100	1	25	4-51-0004	Carrier Assy,Upper Belt	1
11	9-99-6813	Transformer,115VPri,35-38sec	1	26	4-51-0008	Bracket Assy.Pvt-RH	1
12a	4-51-0103	Lock Assy, Fail Safe	1	26a	9-58-0008	Clevis Pin, 3/8"x1 1/4"	2
12b	4-51-0104	Lock Assy, Fail Secure	1	26b	9-99-0232	Bearing, Flanged	2
13	4-51-0006	Idler Pulley Assy.	1	~	9-73-0080	Panic Switch,Magnet,NO	2
14	4-51-0010	Terminal Block Assy	1				

5100 SX PANEL PARTS

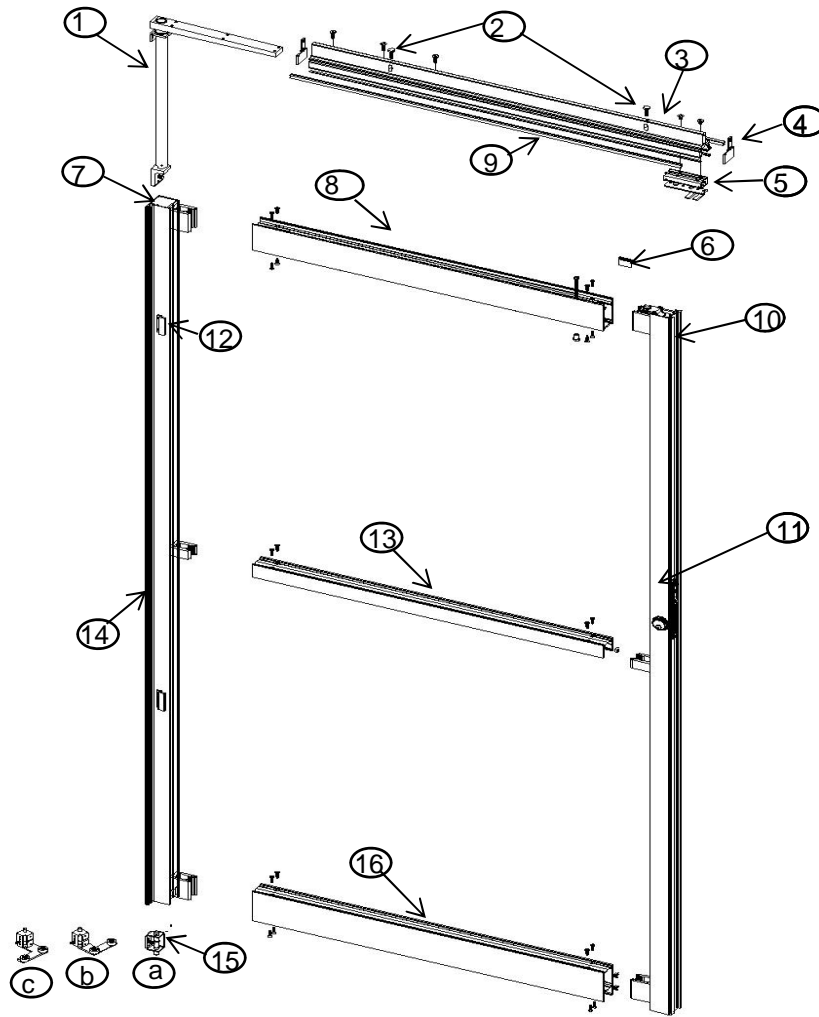

Item	Part Number	Description	Qty.	Item	Part Number	Description	Qty.
1	4-51-0011	Torque Bar Assy.	1	11c	9-99-0071	Deadlock, Hookbolt	1
2	81-0718-3666	Bolt, 1/4-20x3/4"HHGr5	2	11d	9-99-0064	Key Cyl. CL-DB,ARCam	1
3	5-51-4006	Door Catch Extr. CL-DB	~	11e	9-99-0069	Cylinder,Thumbturn,CL-DB	1
4	4-51-1049	End Cap, Door Catch	2	12	4-11-4095	Interlock, DB	2
5a	4-51-0015	Interlock Assy, LH, Catch	1	13	5-11-4031	Muntin Extr., 1 1/2", CL-DB	~
5b	4-51-0016	Interlock Assy, RH, Catch	1	14a	9-99-7316	Weatherpile, Channel	1
6	4-51-9004	Cover, Door Catch, Plastic	1	14b	6-51-9002	Channel, Weatherpile	1
7a	4-11-4111	Stile, Sliding, RH Pivot, CL-DB	1	15a	4-11-0469	Pin Guide Assy	1
7b	4-11-4113	Stile, Sliding, LH Pivot, CL-DB	1	15b	4-11-0470	Fxd Pnl Bottom Guide Assy-LH	1
8	5-51-4009	Rail Extr., Top, 3", CL-DB	~	15c	4-11-0471	Fxd Pnl Bottom Guide Assy-RH	1
9	9-99-7318	Weatherpile, Catch, Black	~	16	5-11-4033	3 1/2" Bottom Rail Extr.	~
10	9-99-7316	Weatherpile, Tandem, Black	~	~	9-99-2834	Door Closer, Concealed	1
11a	4-11-4108	Stile, Lock, Sliding, CL-DB	1	~	4-51-9005	Slide Block, SX, Closer	1
11B	4-11-4125	Stile, Lock Catch, CL-DB	1	~	4-51-1054	Stud, closer	1
				~	9-99-0072	Dummy Cylinder, CL-DB	1



5100 SO Panel Parts

3-12

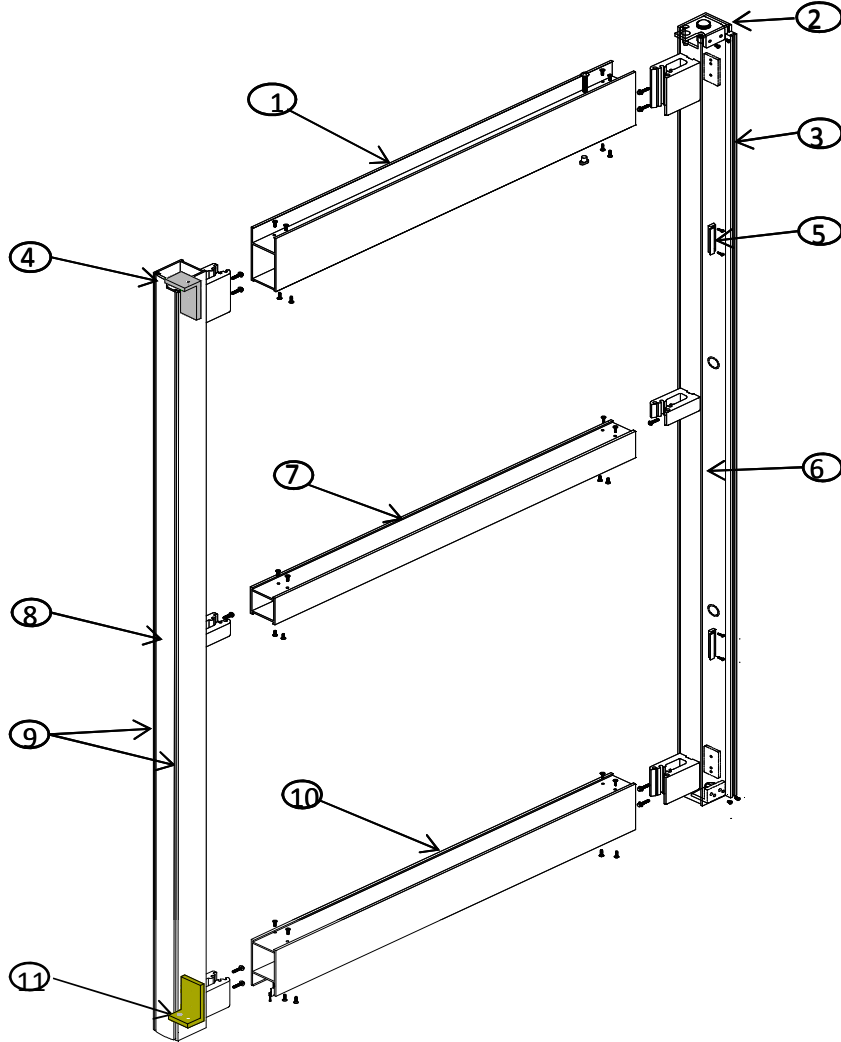

Item	Part Number	Description	Qty.	Item	Part Number	Description	Qty.
1	5-11-4034	Rail Extr., 4" Upper CL-DB	~	7	5-11-4031	Muntin Extr., CL-DB, 1 1/2"	~
2	4-51-0096	Roller Catch & Magnet Assy	2	8a	4-51-4136	Pivot Stile, CL-DB, LH	1
3a	6-51-9002	Channel, Weatherpile	1	8b	4-51-4137	Pivot Stile, CL-DB, RH	1
3b	9-99-7316	Weatherpile, Channel	1	9	9-99-7316	Weatherpile, Mohair, BL	~
4a	4-11-0432	Angle Assy, Top Pvt.-LH	1	10	5-11-4033	Rail, Bottom, 3 1/2" CL-DB	1
4b	4-11-0433	Angle Assy, Top Pvt.-RH	1	11a	4-11-0434	Angle Assy, Bott Pvt-LH	1
5	4-11-4095	Interlock, DB	2	11b	4-11-0435	Angle Assy, Bott Pvt-RH	1
6a	4-51-4138	Beam Stile, CL-DB, LH	1	~	4-11-1031	Pin, Sidelite, Bottom	1
6b	4-51-4139	Beam Stile, CL-DB, RH	1	~	4-51-4008	Block, Sidelite, Bottom	1
~	5-11-4040	Sash, 1/4" Square, CL-DB	~	~	9-99-7347	Holder, Sweep(BL) Straight	8ft.
~	5-11-4039	Gutter, 1/4" Square, CL-DB	~	~	9-99-7348	Holder, Sweep(BL) Angled	8ft.
~	5-11-4042	Sash, 1" Square, CL-DB	~	~	9-99-7358	Brush, Sweep, Short(BL)	8ft.
~	5-11-4041	Gutter, 1" Square, CL-DB	~	~	9-99-7362	Brush, Sweep, Air/Smoke	8ft.
				~	5-11-4008	Ramped Pin Guide Track-MF	~
				~	5-51-4013	Ramped Pin Guide Track-MF-Tele	



5100 "O" PANEL PARTS

3-12

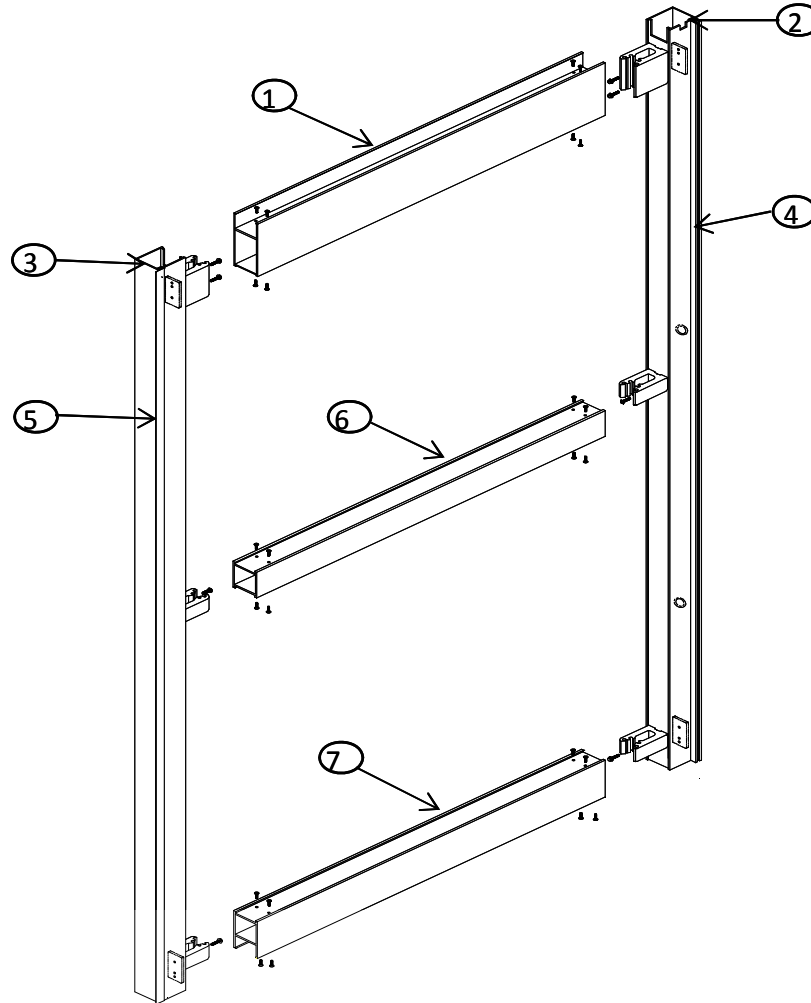

ITEM	PART NUMBER	DESCRIPTION	QTY.
1	5-11-4034	Upper Rail, 4", CL-DB	1
2a	4-11-4134	Stile, Beam, RH, CL-DB	1
2b	4-11-4138	Stile, Beam, LH, CL-DB	1
3	4-11-4136	Stile, Jamb Side, CL-DB	1
4a	9-99-7316	Weatherpile, Channel	~
4b	6-51-9002	Channel, Weatherpile	~
5	6-11-9005	Vinyl, Sidelite Seal	~
6	5-11-4031	Muntin, 1 1/2" CL-DB	~
7	5-11-4032	Bottom Rail, 2 1/2" CL-DB	~
~	6-11-9007	Glass Setting Block	~
~	6-11-9002	Insert, Glazing	~
~	5-11-4028	Filler, Stile, CL-DB	~
~	5-51-4011	10" Bottom Rail, CL-DB	~
~	5-51-4010	9" Bottom Rail, CL-DB	~
~	5-51-4016	Bottom Guide Rail, CL-DB	~

CONTROL TERMINAL BLOCK CONNECTIONS

- | | |
|---|---|
| 1 - Exterior Sensor - Power - 0V | 21 - Interior Sensor - Power - 0V |
| 2 - Exterior Sensor - Power/Signal - +24V | 22 - Interior Sensor - Power/Signal - +24V |
| 3 - Exterior Sensor - Signal | 23 - Interior Sensor - Signal |
| 4 - Emergency Open / Close | 25 - Electronic Control Panel / ADM - Data# |
| 5 - Auxiliary Power - +24V | 26 - Electronic Control Panel / ADM - DataL |
| 6 - Auxiliary Sensor - Signal
(Threshold Safety / Side Screen) | 27 - Electronic Control Panel / ADM - +24V |
| 7 - Auxiliary Power - 0V | 28 - Electronic Control Panel / ADM - 0V |
| 8 - Alarm Relay - N.C. | 30 - Safety Beam - Emitter 1 + |
| 9 - Alarm Relay - COM | 31 - Safety Beam - Emitter 1 - |
| 10 - Alarm Relay - N.O. | 32 - Safety Beam - Receiver 1 + |
| 11 - Emergency Breakout - Signal | 33 - Safety Beam - Receiver 1 - |
| 12 - Emergency Breakout - +24V | 34 - Safety Beam - Emitter 2 + |
| 13 - Remote Activation - +24V | 35 - Safety Beam - Emitter 2 - |
| 14 - Remote Activation - Signal | 36 - Safety Beam - Receiver 2 + |
| 15 - Optional Switch Control Panel - +24V | 37 - Safety Beam - Receiver 2 - |
| 16 - Optional Switch Control Panel - AUTO | |
| 17 - Optional Switch Control Panel - 1W / PO | |
| 18 - Optional Switch Control Panel - 0V | |

Note: For proper operation, use the harness provided with sensors to be installed.
All wiring should be routed away from moving parts in door operator.
Power available from operator for sensors is 24VDC, 1A.

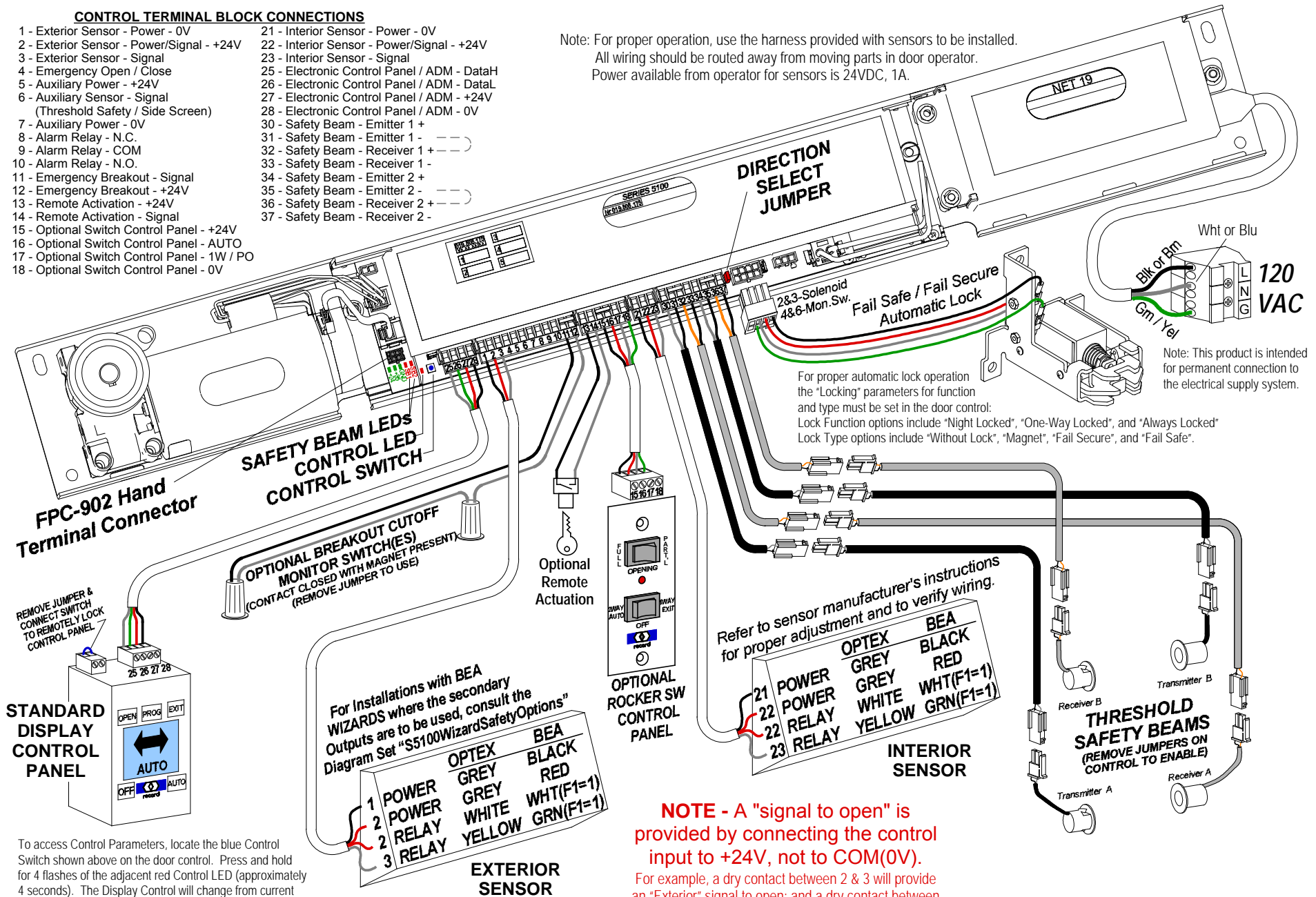

Note: This product is intended for permanent connection to the electrical supply system.

For proper automatic lock operation the "Locking" parameters for function and type must be set in the door control:
Lock Function options include "Night Locked", "One-Way Locked", and "Always Locked"
Lock Type options include "Without Lock", "Magnet", "Fail Secure", and "Fail Safe".

Refer to sensor manufacturer's instructions for proper adjustment and to verify wiring.

21 POWER	OPTEX	BEA
22 RELAY	GREY	BLACK
23 RELAY	GREY	RED
	WHITE	WHT(F1=1)
	YELLOW	GRN(F1=1)

For installations with BEA Outputs are to be used, consult the Diagram Set "S5100WizardSafetyOptions"

1 POWER	OPTEX	BEA
2 POWER	GREY	BLACK
2 RELAY	GREY	RED
3 RELAY	WHITE	WHT(F1=1)
	YELLOW	GRN(F1=1)

NOTE - A "signal to open" is provided by connecting the control input to +24V, not to COM(0V).
For example, a dry contact between 2 & 3 will provide an "Exterior" signal to open; and a dry contact between 22 & 23 will provide an "Interior" signal to open.

REMOVE JUMPER & CONNECT SWITCH TO REMOTELY LOCK CONTROL PANEL.

STANDARD DISPLAY CONTROL PANEL

To access Control Parameters, locate the blue Control Switch shown above on the door control. Press and hold for 4 flashes of the adjacent red Control LED (approximately 4 seconds). The Display Control will change from current operating mode (OFF / AUTO / EXIT / OPEN) to the Parameter adjust screen. Use the OFF and AUTO buttons to scroll up and down; use the "record" button to select, and use the PROG button to step back. Press PROG several times to return to Operating Mode.

SERIES 5100 STANDARD WIRING DIAGRAM

Feb10 DPH

