

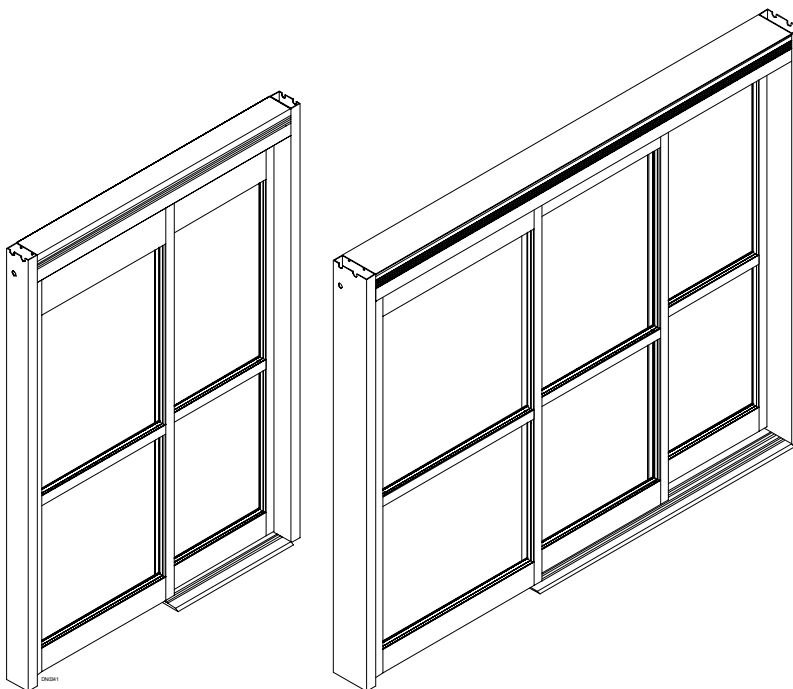

Automatic Entrance Systems

GT2150 Manual Slider Installation (2-Panel Slider & 3-Panel Telescopic)



WARNING

Do not install, operate or service this product unless you have read and understand the Safety Practices, Warnings, and Installation and Operating Instructions contained in this manual. Failure to do so may result in property damage or bodily injury.

NABCO ENTRANCES INC.
Phone: 877-622-2694 Fax: 888-679-3319
Technical Assistance: 1-866-622-8325
<http://www.nabcoentrances.com>
Email: CustomerService@NabcoEntrances.com

15-12941 Revision 07-26-10

Table of Contents

Objective _____	4
Masonry Opening (MO) Preparation _____	5
Framing and Header Assembly _____	5
Telescopic Units (Track Removal.) _____	5
Installation of Floor Track _____	7-8
Installation of Swing Panel _____	9-10
Door Installation _____	11
Adjusting Door Preload _____	12
Door Panic Adjustment _____	13

CAUTION!

IMPORTANT INFORMATION FOR THE INSTALLER AND OWNER

Read All of This First!

Read these safety practices before installing, operating, or servicing the door. Failure to follow these practices may result in serious consequences.

Read, study, and understand the operating instructions contained in or referenced in this manual before operating. If you do not understand the instructions, ask the installing qualified technician to teach you how to use the door.

Do not install, operate, or service this product unless you have read and understand the Safety Practices, Warnings, and Installation and Operating Instructions contained in this manual. Failure to do so may result in property damage or bodily injury.

This manual and the owner's manual must be given to and retained by the purchasing facility or end user.

1. If the door appears broken or does not seem to work correctly, it should be immediately removed from service and a qualified service technician contacted for corrective action.
2. It is the responsibility of the purchasing facility or end user to keep warning and instructional labels and literature legible, intact and with the door.
3. Replacement labels and literature may be obtained from local NABCO Entrances Inc.

TO THE INSTALLER:

The purpose of this manual is to familiarize the purchaser with the proper installation and operation of this system. It is essential that this equipment be properly installed and operational before the door is used by the public. It is the installer's responsibility to inspect the operation of the entrance system to be sure it operates in accordance with all installation requirements. Local standards or codes may apply.

Instruct the building owners and operator on the essentials of the operation of the door and this device. The owner should follow these instructions to determine whether the door is operating properly and should immediately call for service if there is any malfunction. All installation changes and adjustments must be made by qualified, NABCO trained technicians.

OBJECTIVE:

The GT2150 series is designed to be installed in a prepared opening or to the surface of a prepared opening. This manual offers step by step instructions to install the GT2150 series slider.

Tool List:	1/2" Wrench: Box or Open End	Phillips Screwdrivers: #2 and #3
	9/16" Wrench: Box or Open End	Hand Drill: Electric or Cordless
	3/8" Drive Socket Wrench	Drill Bits: 1/8"
	3/8" Socket	37/64"
	9/16" Socket	5/16" Masonry
	6" Socket Extension	Level
	Allen Wrenches: 1/8", 1/4" and 5/32"	Chalk Line

A. Masonry Opening (MO) Preparation

1. Check floor across entire opening. Make sure installation area is level.
2. Allow for tile or other materials that may change floor height.
3. MO width should be package width plus 1/4-inch per side. (see Figure 1).

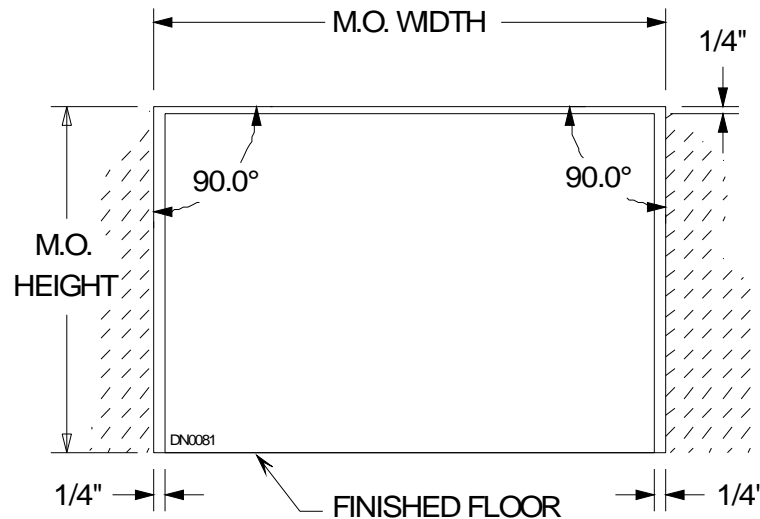

Figure 1

B. Framing and Header Assembly

1. Place header on a flat surface with removable cover facing up. Protect header from scratches.
2. Open cover (see Figure 3 pg. 5). Remove parts box. Set aside.

NOTE: For telescopic units go to section C.

3. Position jamb tubes on each end of header. Fasten with provided 1/4-20 x 3/4-inch self-tapping bolts (see Figure 4 pg. 5).
4. Lift header and jamb tubes into position.
5. Level header assembly by shimming under appropriate jamb if necessary.
6. Plumb one jamb tube in both planes. If required, shim back of jamb (see Figure 5 pg. 5). Fasten jamb to building.
7. Plumb and securely fasten other jamb.
8. Adequately fasten through header to structure above with the appropriate type of fastener. Fasteners 24-inch O.C. recommended.

C. Telescopic Units (Track Removal.)

1. To remove roller track, loosen the screw holding the roller track clamp and turn clamp 90 degrees. Retighten screw to hold clamp in place while removing track (see Figure 2, Pg. 5).
2. Remove roller track (see Figure 3 pg. 5).
3. Continue with item 3, section B.

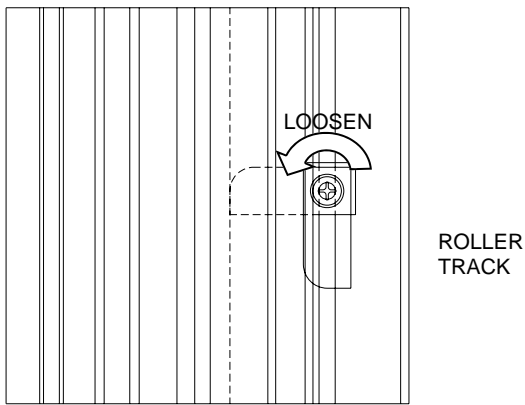
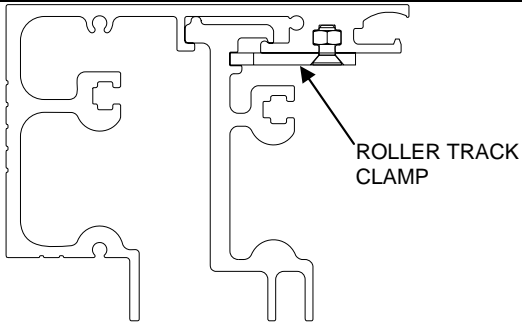

Figure 2

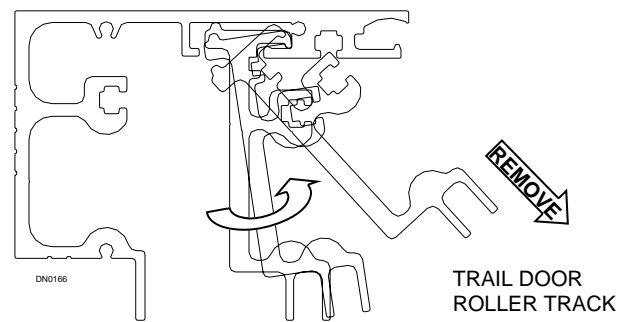
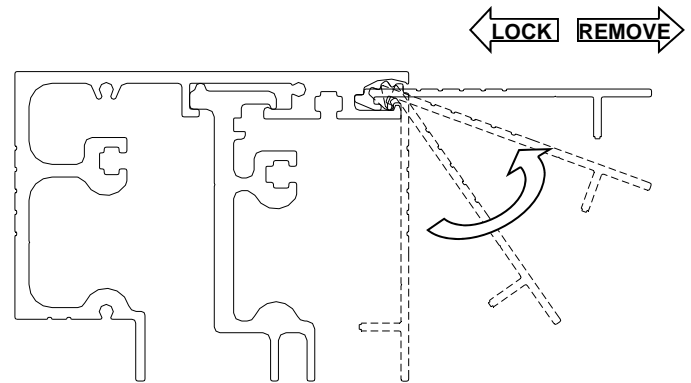

Figure 3

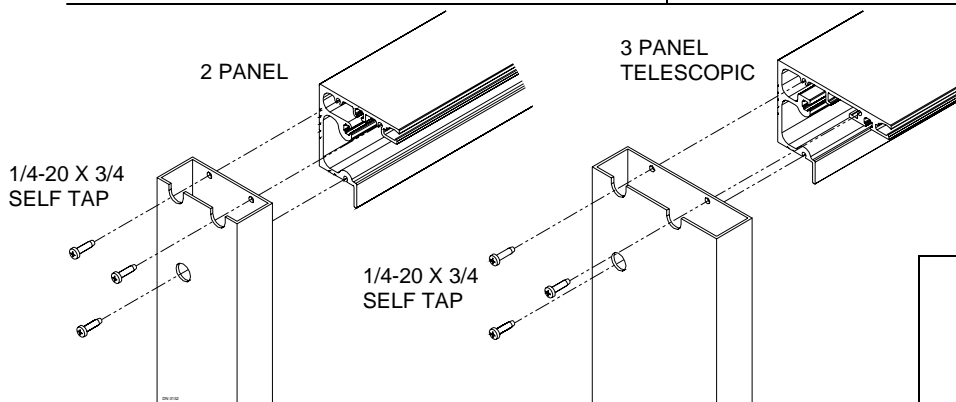

Figure 4

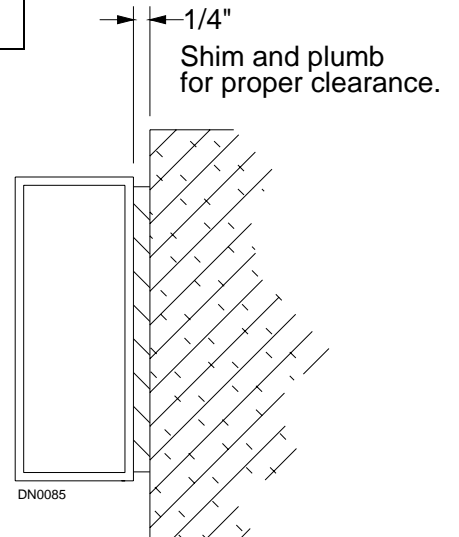

Figure 5

D. Installation of Floor Track

1. Snap chalk line on floor from jamb to jamb (see Figure 8) on interior side of building.
2. Extending the floor track across entire opening is optional. Contact customer service at (877) 622-2694 to order additional track.

NOTE: Install a filler strip in clear opening when extending floor track across entire door opening. This will be factory installed when full length track is specified at ordering (see Figure 7). Filler strips are removed under SO panel (see Figure 7).

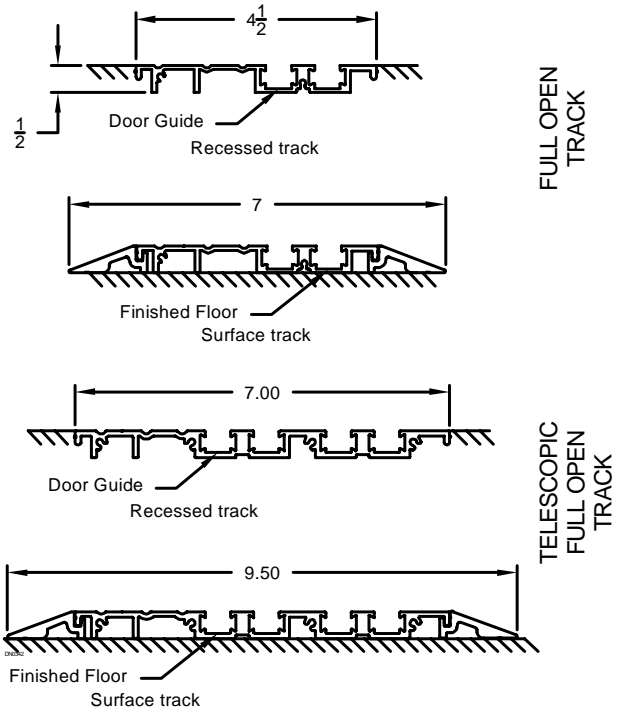

Figure 6

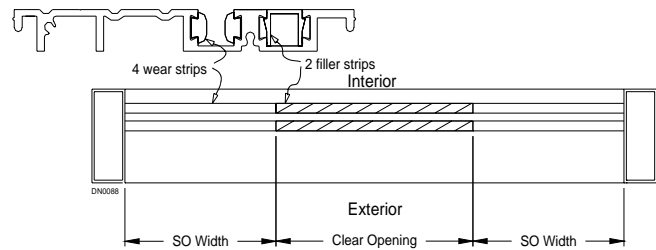

Figure 7

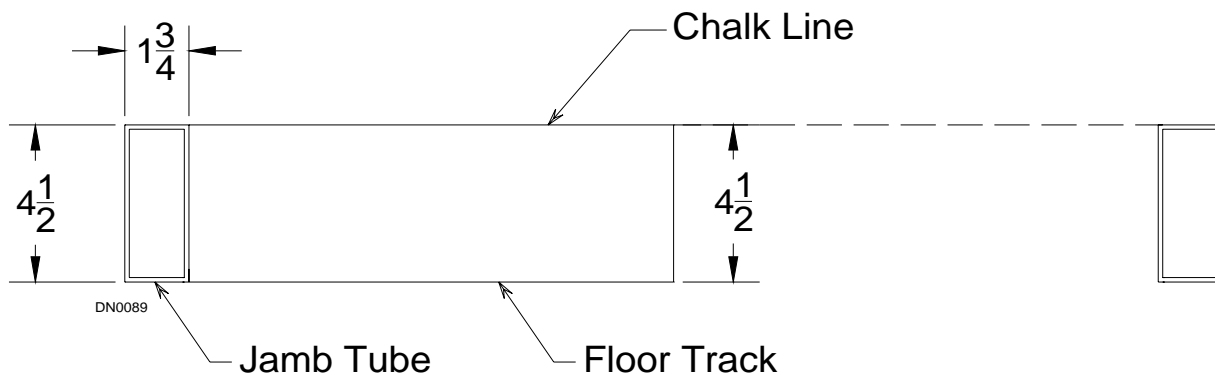

Figure 8

3. Locate track flush with chalk line.
4. Mark location of track holes on floor. Fasten track to floor with plastic anchors and #10 x 1-1/2-inch screws provided in parts box.
5. The extrusion is designed to install in-line with jamb tubes. This makes recessing the floor track simple. A 1/2-inch deep by 4-1/2-inch wide (7-inch on telescope units) channel across entire opening is all that is required for recessing the unit. Jamb tubes are recessed into floor with threshold.
6. A screw spline has been extruded on the underside of the threshold. Stainless steel caps and screws are supplied in parts box to seal off exposed end of threshold. If screws install tightly, try drilling spline with a 1/8-inch dia. drill bit (see Figure 9).

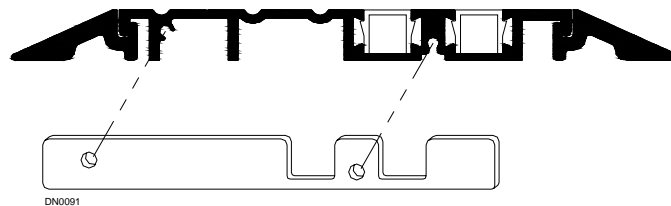

Figure 9

NOTE: If you would like to retrofit an older installation with this closeout, contact customer service to request the caps (PN 24-9857-10) and three screws (PN 24-0094-12). If the screw spline is not in the track, new threshold should be ordered as well. One set of the above parts for each exposed track.

E. Installation of Swing Panel

1. Locate swing panel pivot in parts box.
2. Install pivot into jamb by rotating it into cutout in jamb and fastening it with a 1/4-20 x 3/4-inch screw (see Figure 10).
3. Drill through barrel of pivot bracket into track with a 7/32-inch drill.
4. Install self-tapping 1/4-20 x 1 inch screw down barrel of pivot into track.
5. For doors in windy conditions or doors that will be broken out often, use a floor anchor and install mounting screw through tab of pivot assembly.
6. Install nylon guide into barrel of pivot.
7. Locate swing panel. It will have a ball detent at top and bottom of nose stile.
8. Install the sidelite by first inserting the bottom pivot pin into the bottom pivot bushing of the pivot assembly .
9. Depress the top pivot pin as shown in Figure 11. Insert the top pivot pin into the hole in the bottom of the header (see Figure 12).
10. Allow pivot pin to snap into hole. Make sure it fully engages hole. If necessary, lift up on retracting pin with a screwdriver.

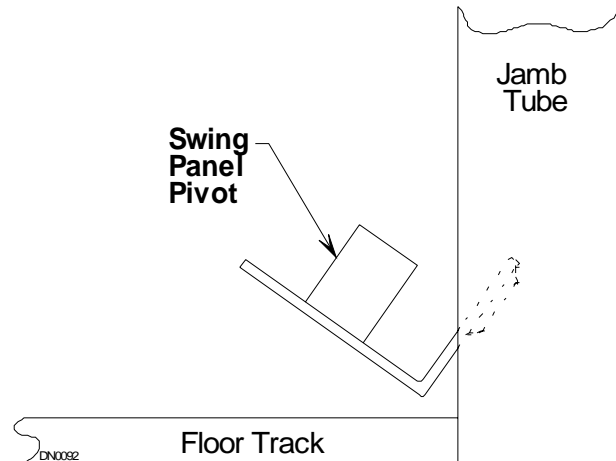

Figure 10

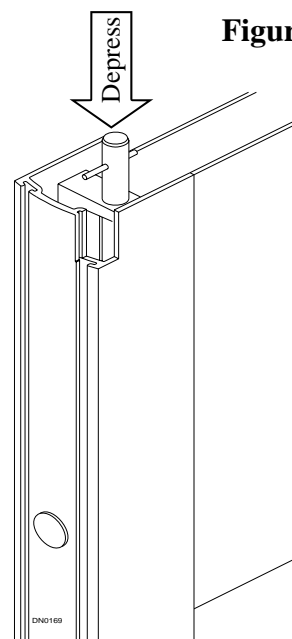

Figure 11

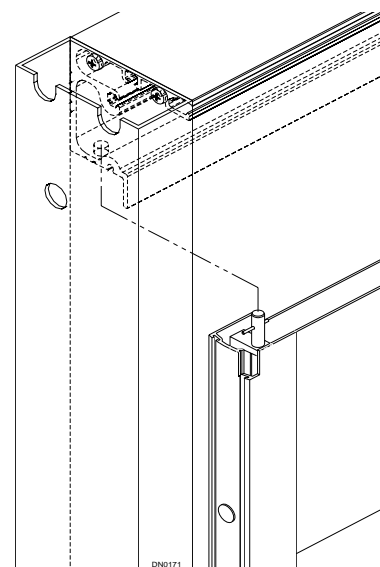

Figure 12

11. Assemble limit arm (see Figure 13). Rest wheel of limit arm inside upper rail of swing panel. Install red coated screw in factory drilled hole on bottom of header. Use one or two large washers as required.
12. With a 15/16-inch open end wrench, adjust both ball detents so they lightly contact header and track surfaces. Additional travel is available by removing ball detent and using alternate mounting holes (see Figures 14 and 15).
13. Open and close swing panel several times to score both surfaces. Adjust height of ball detent if necessary.
14. Locate point where score marks intersect the second centering groove (see Figure 16) on bottom of header and the only groove on floor track. Start with a 1/4-inch diameter drill; drill a hole at each location and countersink it to 3/8-inch x 82°. Test fit of ball detent by closing swing panel and breaking it open. Increase hole and countersink size until satisfactory fit is obtained.
Caution: Do not over-drill the hole. If the hole is over-drilled the track will need to be replaced.
15. The force provided by ball detent is also adjustable. Remove ball detent and bracket assembly from bottom or top of stile. With a blade screwdriver, tighten or loosen brass cap on rear of ball detent. Reinstall ball detent and bracket assembly into stile. Test and repeat if necessary.
16. Readjust ball detents for proper break-out resistance to meet ANSI A156.10 or local code.

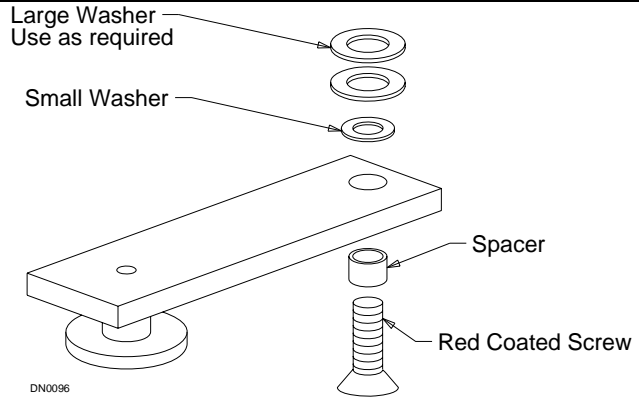

Figure 13

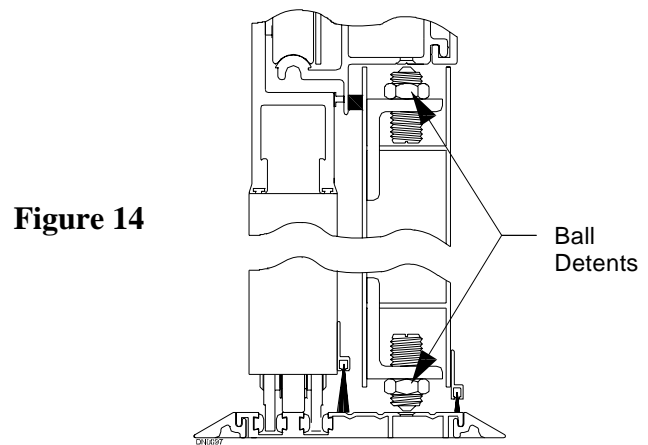

Figure 14

Figure 15

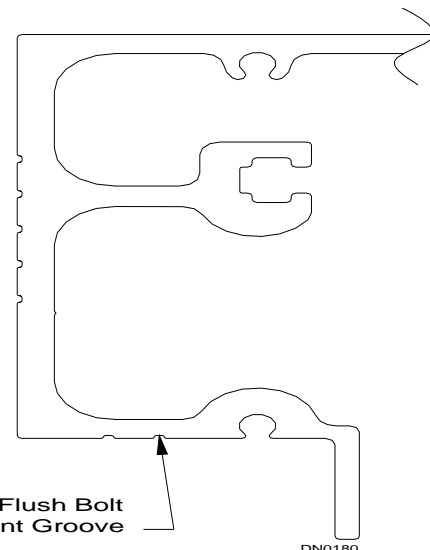
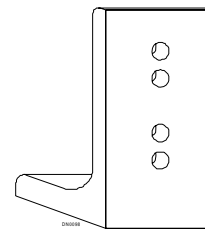

Figure 16

F. Door Installation

1. Looking at the bolt head, position the rollers as shown in Figure 19 with the rollers on the left in toward each other and the rollers on the right out away from each other.
2. Position door over floor track and insert forks of the bottom pivot into floor track as shown in Figure 14.
3. Set rollers onto track in header as shown in Figure 18.
4. Using a 1/2-inch box end wrench and 5/32-inch Allen Wrench set the height of the door and engage the anti-rise rollers.
5. To set the door height. Loosen the nut on the one of the rollers. While holding the wrench on the nut raise or lower the door as needed by turning the bolt with the Allen wrench, clockwise to raise, counterclockwise to lower. (If you need to lower the door you will also need to loosen the anti-rise roller.) Tighten the nut once the bottom of the door is level with the bottom of the sidelite. Level both ends of the door by adjusting the rollers as needed.
6. For Telescopic Units it will be necessary to remove the second roller track to adjust the height of the trail panel (see Figure 3 Page 5)

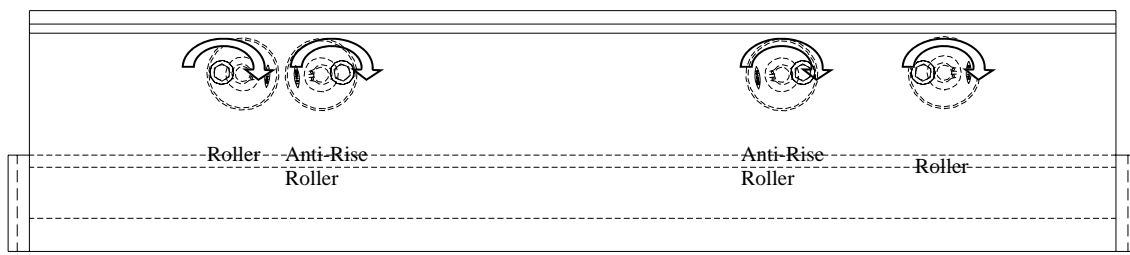

Figure 17

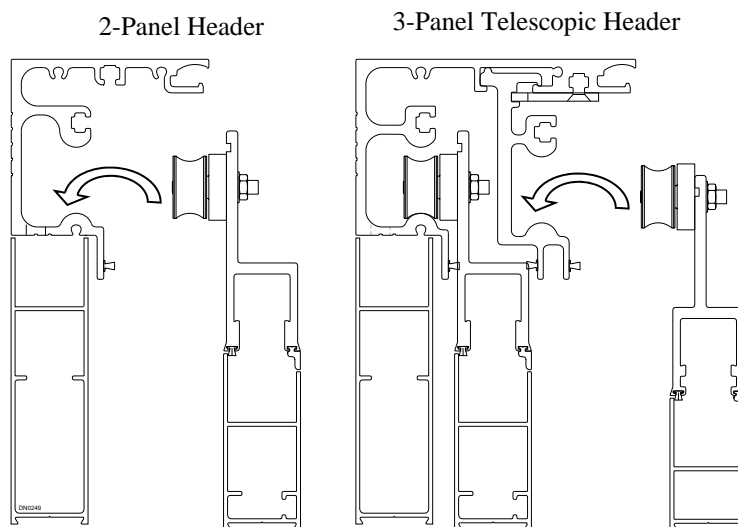

Figure 18

G. Adjusting Door Preload (Glass Must Be Installed!)

1. Panic door open to check door sag (see Figure 19).
2. Loosen two locking bolts on block inside top rail of door (see Figure 20).
3. Adjust door sag by rotating set screw on back edge of door with a 1/8-inch Allen wrench. Door should latch without having to adjust panel.
4. Retighten locking bolts.

NOTE: If the preload necessary for proper operation of the door results in a misalignment of the strike end of the door and hanger, continue with steps 5–7 (see Figure 21).

5. Loosen the Allen head fasteners in the pivot bar and slide the pivot bar in the hanger until the door and hanger are properly aligned.
6. Verify that the panic catch in the top rail of the door and the hanger are still aligned.
7. If necessary loosen the set screws for the panic catch in the hanger and reposition to align with the panic catch in the top rail.

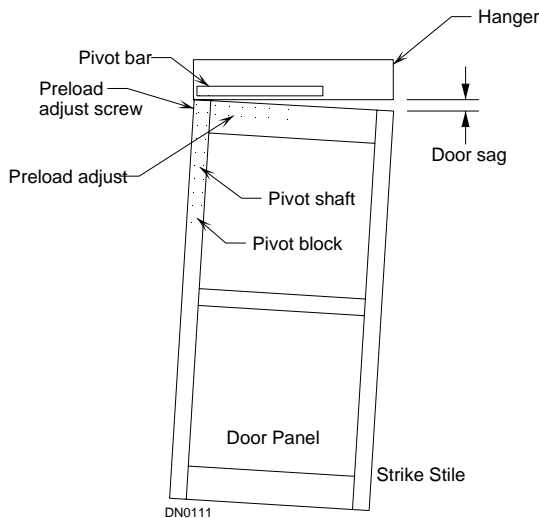

Figure 19

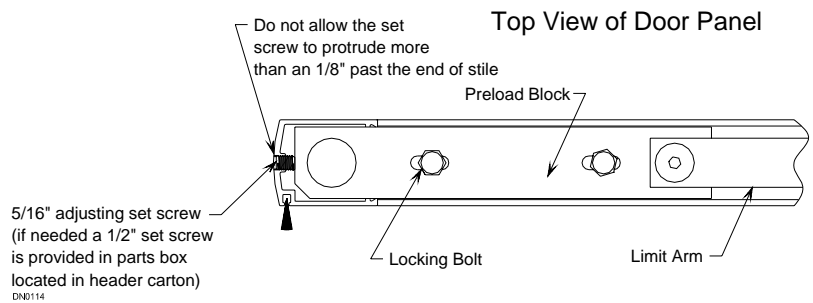

Figure 20

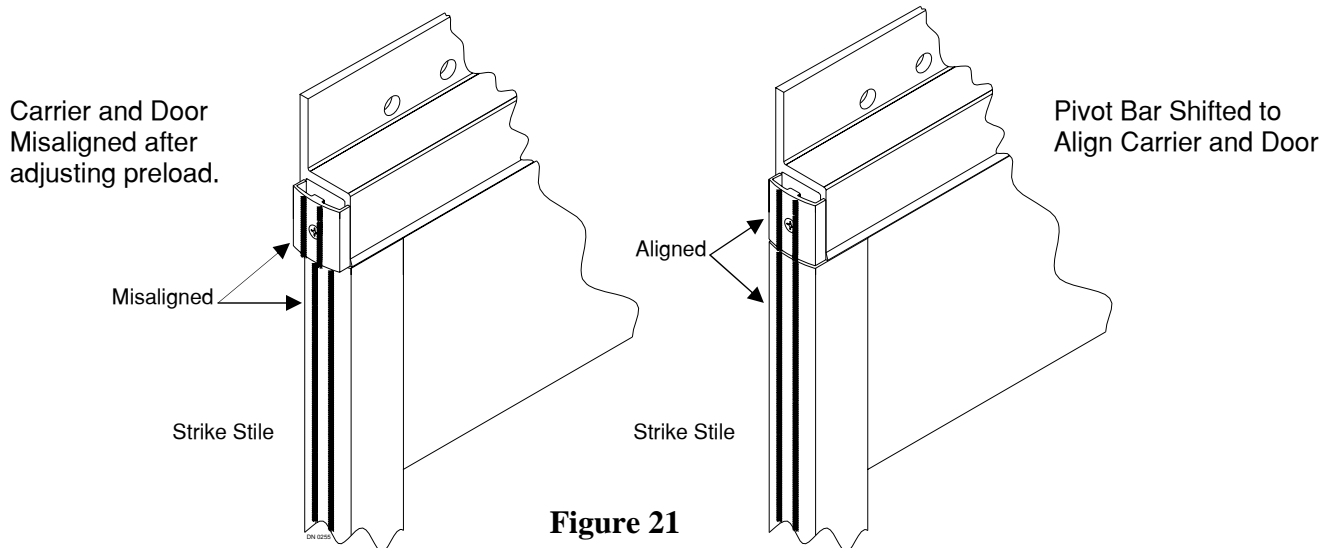

Figure 21

H. Door Panic Adjustment

NOTE: Panic adjustment should be made after glass is installed and door preload is adjusted. The weight of the door with glass installed will affect the amount of force required to panic door open. If force required to panic door is not acceptable, it can be adjusted by performing the following steps.

1. Panic door open. This may require slightly lifting the door or a slight hit with a rubber mallet to the top rail approximately three inches from the nose of the door. Protect the surface of the door to prevent damage.
2. Remove panic block in top of door (see Figure 22).
3. Loosen set screw on front of block.
4. Raise or lower ball plunger with screw on underside of block. Adjust plunger for breakout resistance to meet ANSI A156.10 or local code.
5. Retighten set screw and reinstall into top of door. Repeat if necessary.

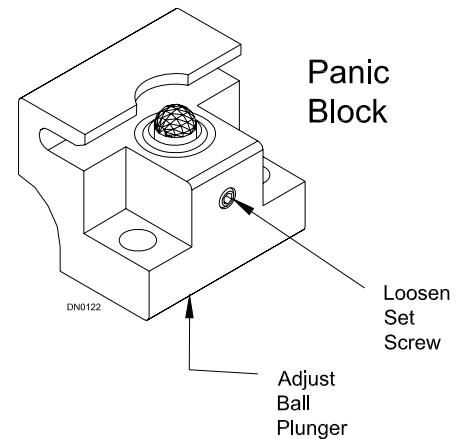

Figure 22