

AUTO-EQUALIZER

LOW ENERGY DOOR OPERATOR

INSTALLATION AND ADJUSTMENT OF DOOR OPERATOR

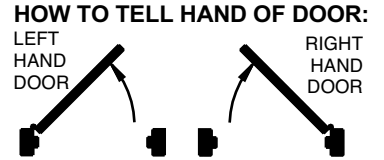
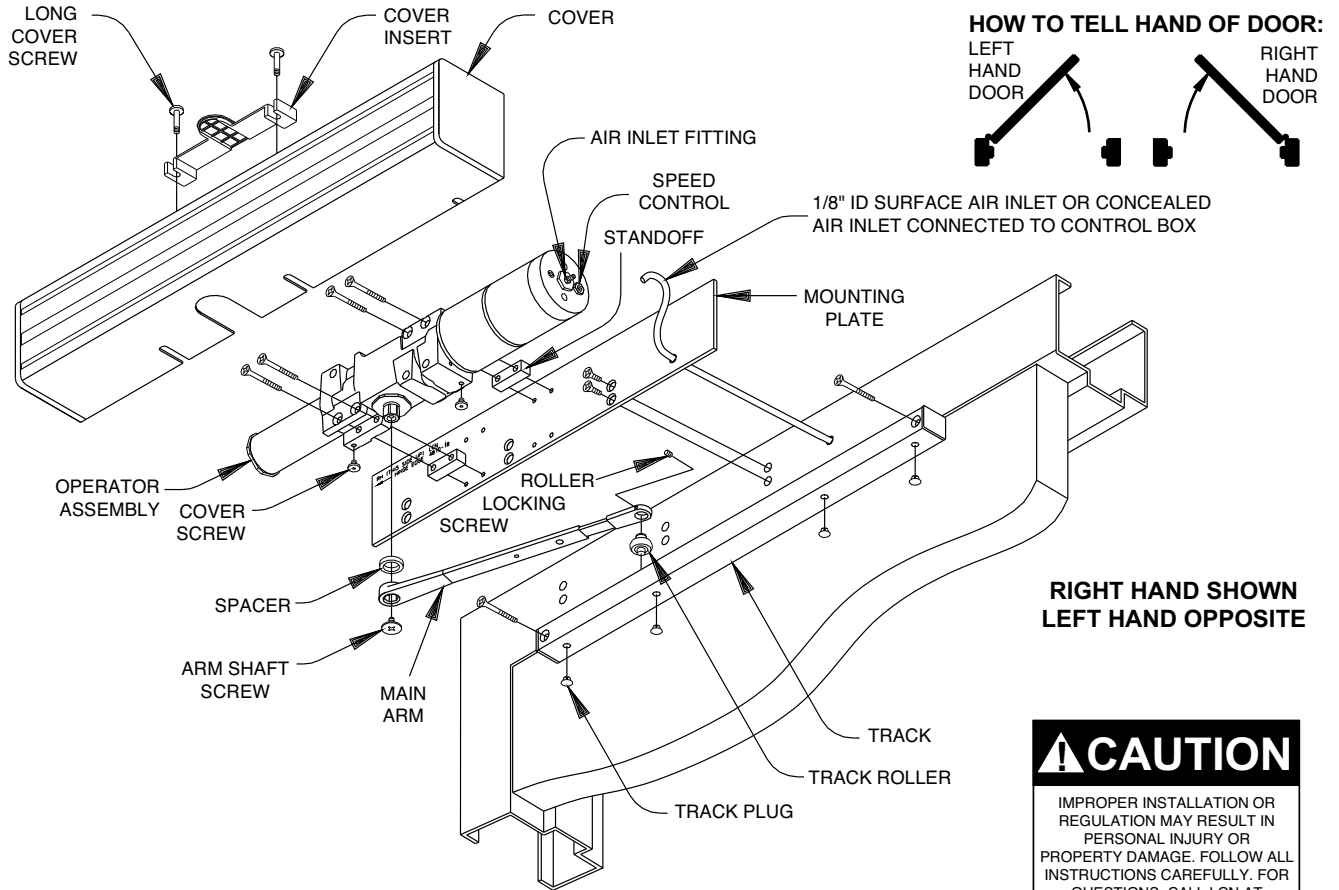

**RIGHT HAND SHOWN
LEFT HAND OPPOSITE**

CAUTION
IMPROPER INSTALLATION OR
REGULATION MAY RESULT IN
PERSONAL INJURY OR
PROPERTY DAMAGE. FOLLOW ALL
INSTRUCTIONS CAREFULLY. FOR
QUESTIONS, CALL LCN AT
800 - 526 - 2400

INSTALLATION

NOTE: This door operator requires additional system components, see LCN Closer Catalog.

1. Prepare frame per template (page 5), then secure mounting plate to frame with screws provided.
2. Secure operator assembly to mounting plate with (4) 1/4 - 20x2 1/2.
3. Connect air line to air inlet fitting.
4. Place spacer on operator shaft, then push arm on to operator shaft at approx. 30° to door. Secure with arm shaft screw.
5. Remove end cap from track, insert track roller, mount track on door and secure with screws provided.
6. Loosen roller locking screw in the end of arm, open door part way (about 30°), pull arm over top of door and connect to track roller. Tighten arm set screw firmly.

CLOSING FORCE

ADJUSTMENT (See Figure 1)

- To adjust **CLOSING FORCE**, turn the spring adjustment nut clockwise to **INCREASE FORCE** or counter-clockwise the required number of turns to match the door width in **Tables 1 & 2**. Maximum adjustment, 5 turns counter-clockwise and 7 turns clockwise.

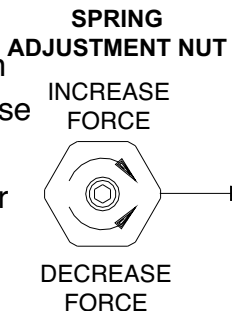
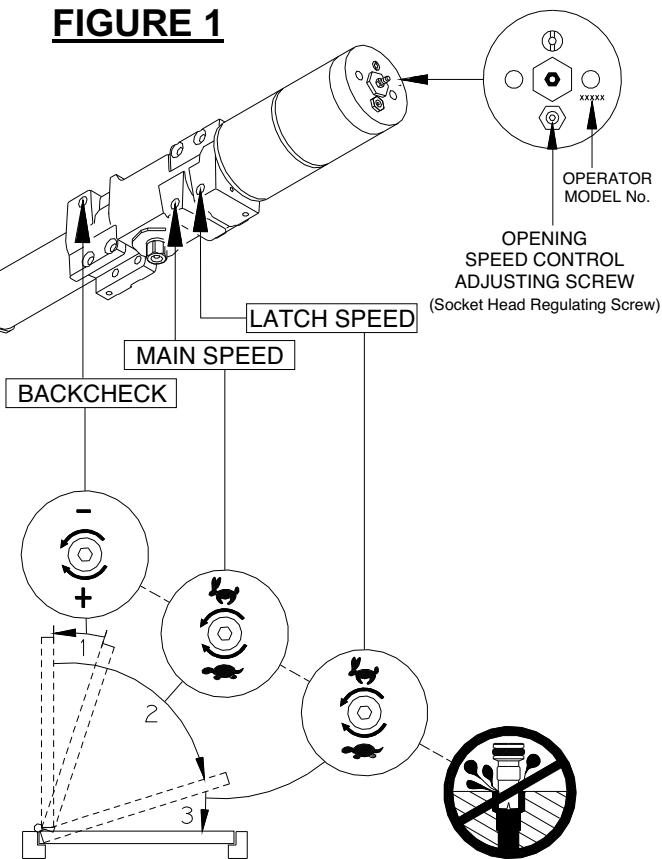

FIGURE 1



CLOSING SPEED

ADJUSTMENT (See Figure 1)

- A "normal" closing time from 90° open position is 5 to 7 seconds, evenly divided between **main speed** and **latch speed**.
- Use 3/32" Allen wrench provided.
- To slow **MAIN SPEED** of door, turn regulating screw (nearest to arm) clockwise.
- To slow **LATCH SPEED** of door, turn regulating screw (nearest to latch) clockwise.
- Do not allow door to slam into frame.

TABLE 1

EXTERIOR DOOR	
MAXIMUM DOOR WIDTH	NUMBER OF TURNS
30"	0 TURNS
36"	2 TURNS C.W.
42"	7 TURNS C.W.

TABLE 2

INTERIOR DOOR	
MAXIMUM DOOR WIDTH	NUMBER OF TURNS
34"	5 TURNS C.C.W.
38"	0 TURNS
48"	2 TURNS C.W.

OPENING SPEED ADJUSTMENT

NOTE FOR AIR PRESSURE REGULATION, SEE CONTROL BOX INSTRUCTIONS

- The door opening speed must be adjusted to suit the width and weight of the door. The wider and/or heavier the door, the slower it should open. To determine opening speed, measure door leaf width and weight and set set speed to open door from 0° to 80° for the time shown in Table 3 below. The opening speed control adjusting screw is located in the end of the door operator near the tubing connection (see figure 1). Using a 3/32" Allen wrench (provided), turn the speed control clockwise to slow the door, counter-clockwise to increase speed.

TABLE 3

Door Weight In Pounds	FASTEST OPENING TIME IN SECONDS TO 80° POSITION		
	Door Width In Inches		
	36"	42"	48"
100 lbs.	3.0 sec.	3.0 sec.	3.0 sec.
125 lbs.	3.5 sec.	3.5 sec.	3.5 sec.
150 lbs.	3.5 sec.	3.5 sec.	3.5 sec.
200 lbs.	4.0 sec.	4.0 sec.	4.0 sec.

NOTE:

If door width or weight is between the sizes listed, use the time shown for the next wider or heavier door.



- If door weight cannot be measured, the weight can be estimated by finding the area of the door (length x width) and multiplying it by the weight per square feet for the door type that is being used as shown in Table 4 below.

TABLE 4

DOOR TYPE	Weight per sq. ft.
Solid Core Wood 20 Ga. Flush Hollow Metal Aluminum x 1" Glass	5.5
Mineral Core Door 16 Ga. Flush Hollow Metal Aluminum x 1" Glass	7.0

NOTE:

These weights are for 1 3/4" thick doors. If the doors are thicker or thinner, consult door manufacture for proper weight or weigh the door.

BACKCHECK ADJUSTMENT

- Backcheck slows the door swing as it approaches full opening (see figure 1 on page 2).
- Increase the resistance of backcheck only if necessary to prevent the door from striking a wall. To do this, turn the regulating screw (nearest to hinge) clockwise by quarter turns. **DO NOT USE AN ABRUPT BACKCHECK.**

DELAY TIME ADJUSTMENT

After opening, the door should remain at the 90° position for no less than 5 seconds. This "Delay Time" can be increased to approximately 30 seconds by turning the timer adjustment wheel(s) in the control box clockwise. For the location of this wheel(s), refer to 7900 or 7980 Series Control Box Instruction Sheet. Adjust "Delay Time" to maximum practical for the elderly or handicapped. Time cycle begins when switch or scanner is activated.

ATTACH COVER

- Slide cover insert into the top cutout in cover (see Figure 4).
- Push cover over the operator assembly and against mounting plate.
- Insert cover screws and tighten securely.

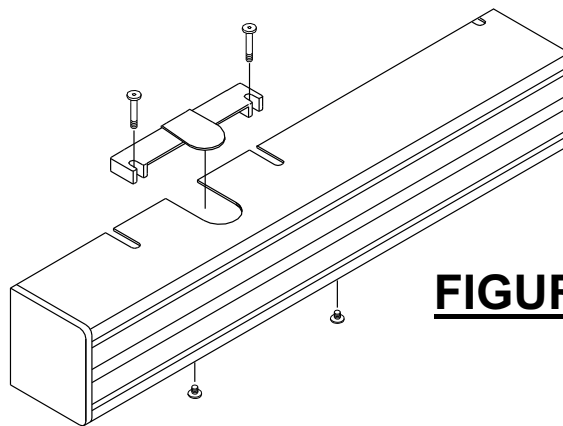
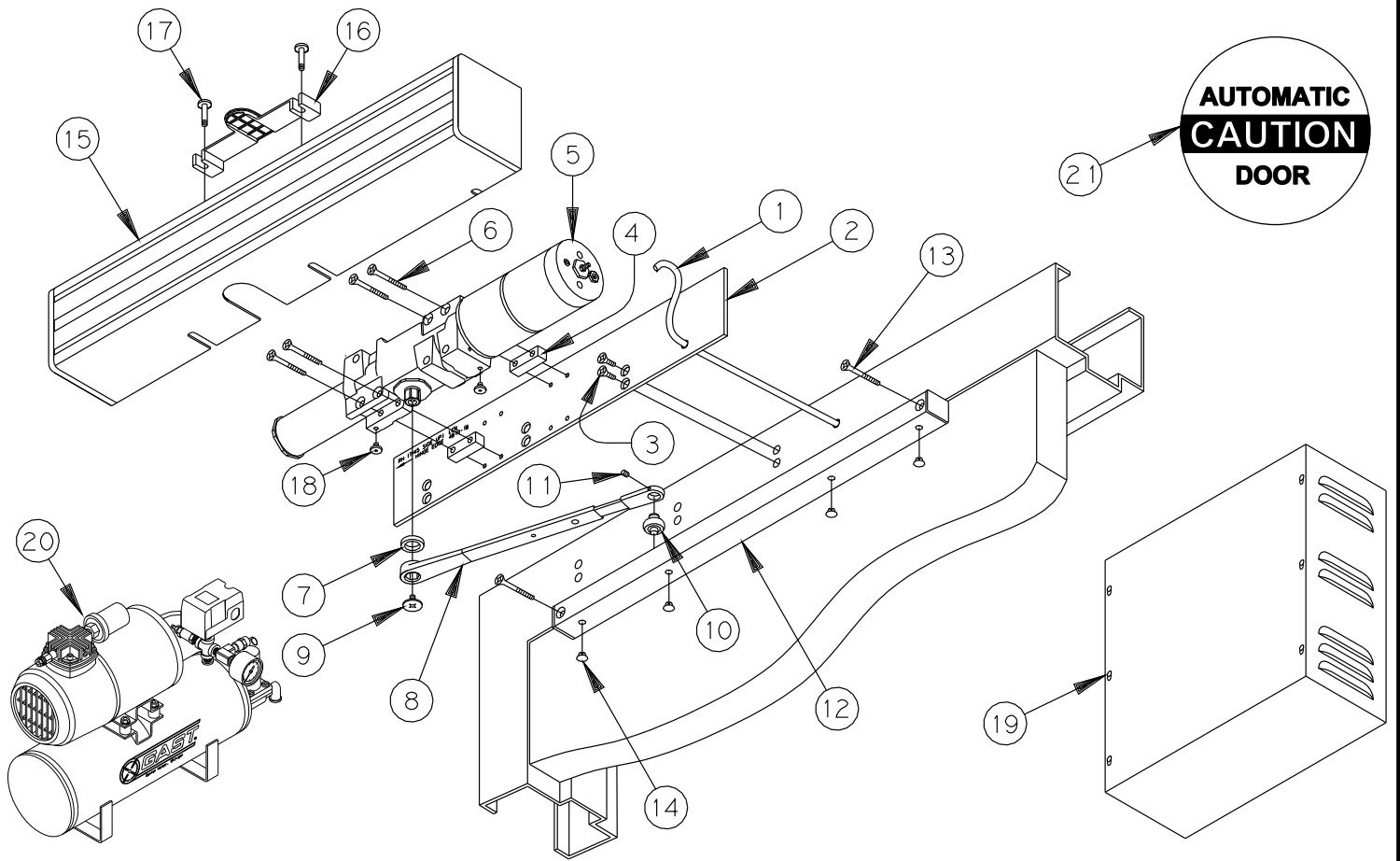

FIGURE 4

LOCATING THE CAUTION / AUTOMATIC DOOR DECAL

- Locate one decal on each side of door near lock stile of door, approximately 53" min. to 63" max. above the floor. The decal location must be visible without interference from door trim, panic devices, etc.
- Clean a 6" x 6" area where decals will be placed.
- Apply one decal (item 16 on page 10) on each side of door. Remove backing and "roll" onto door to avoid trapping air under decal.



ITEM No.	PART No.	DESCRIPTION	QUANTITY
1	925	1/8" I.D. Pneumatic Tubing	Order Length Required
2	4810-18	Standard Mounting Plate	1
3	No. 14 x 1 1/2" 1/4-20 x 5/8"	Phillips Head Wood Screw or Phillips Head Machine Screw	6
4	4810-182	Standoff	2
5	4810-3071	LCN Switch-Actuated Auto Equalizer	1
6	No. 1/4-20 x 2 1/2"	Phillips Head Machine Screw	4
7	4810-61	Spacer	1
8	4810-3077	Arm	1
9	4810-159	Arm Shaft Screw	1
10	4810-3034	Track Roller	1
11	4810-425	Roller Locking Screw	1
12	4810-3038	Track	1
13	No. 14 x 2 1/2" No. 1/4-20 x 1 1/2"	Phillips Head Wood Screw Phillips Head Machine Screw	2
14	4810-141	Track Plug	4
15	4810-72	Cover	1
16	4810-163	Cover Insert	1
17	4810-31L	Long Cover Screw	2
18	4810-31	Cover Screw	2
19	7900 or 7980 Series	Control Box	1
20	920 Series	Compressor (optional)	1
21	4820-155G	Decal	2

SINGLE LEVER ARM SET SCREW ADJUSTMENT

1. It may be necessary to adjust the fully open door position. Minor adjustment can be obtained by using the telescoping arm as follows (see figure 5):
 - A. Shorten length of arm to decrease door opening.
Lengthen arm to increase door opening.
 - B. Remove set screw and adjust arm to preferred length.
 - C. Replace set screw and tighten securely after adjustment.
 - D. After arm adjustment is made, cycle door to ensure that it is operating properly.

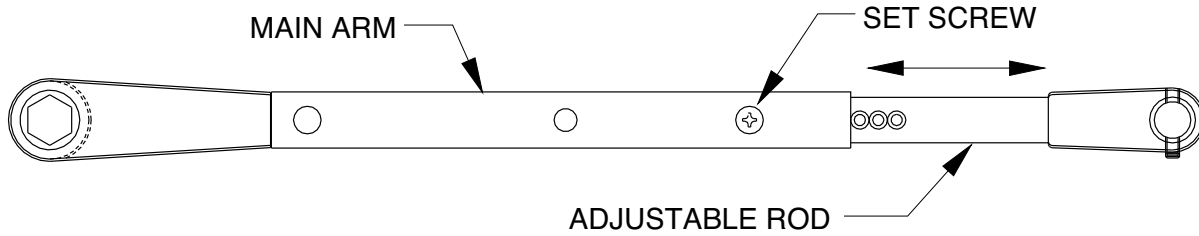
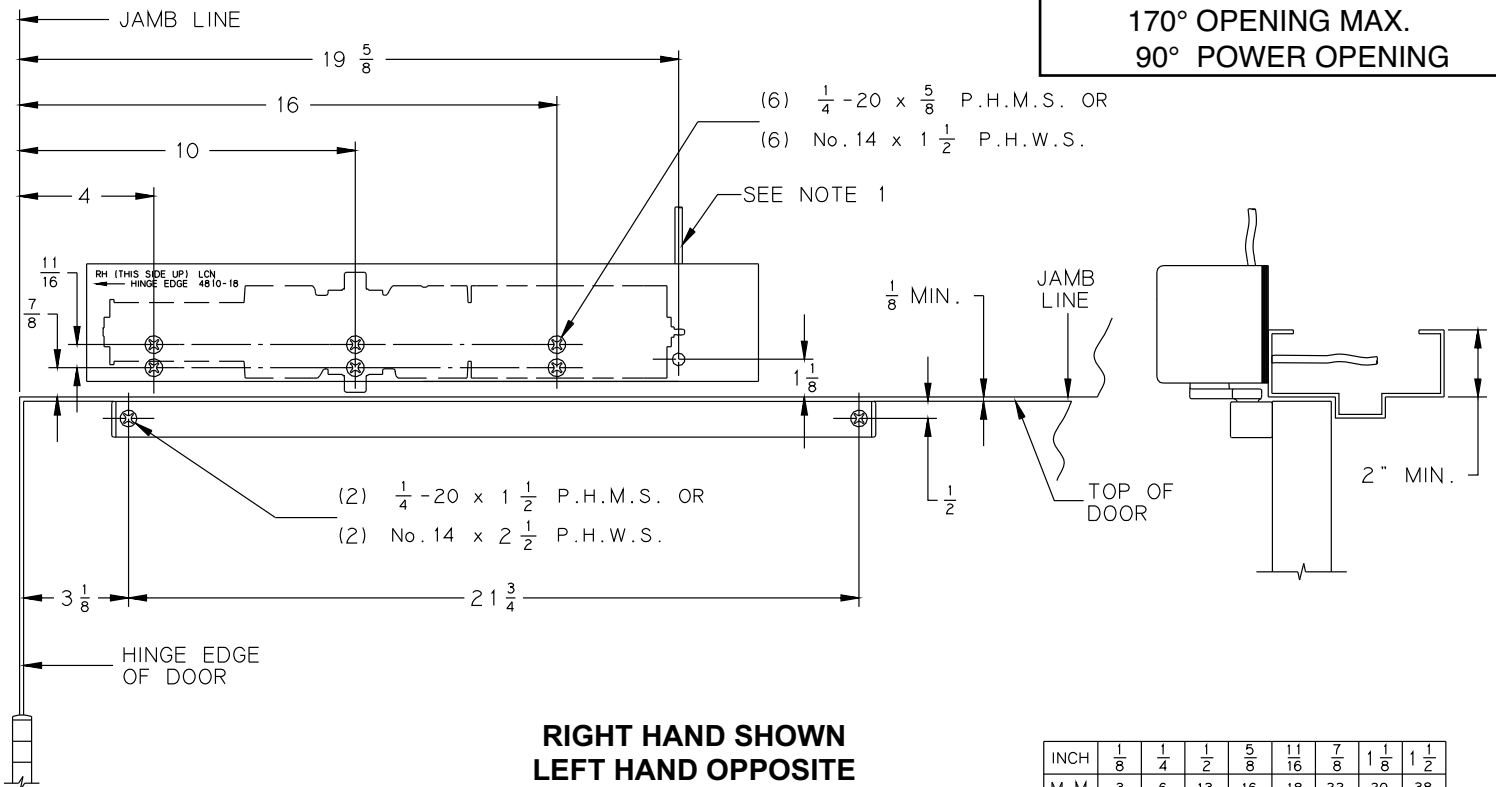

FIGURE 5

THIS TEMPLATE APPLIES TO
170° OPENING MAX.
90° POWER OPENING



**RIGHT HAND SHOWN
 LEFT HAND OPPOSITE**

GENERAL NOTES:

1. 1/8" I.D. Tubing connected to control box.
2. Locate closer & track from \mathcal{C} of pivot or swing clear hinges when used.
3. Auxiliary stops are recommended at maximum opening.
4. Closer size 20" x 3 1/2" x 3 5/16".
5. Reinforcing per ANSI/SDI-100 recommended for hollow metal doors & frames.

INCH	1/8	1/4	1/2	5/8	11/16	7/8	1 1/8	1 1/2
M.M.	3	6	13	16	18	22	29	38
INCH	2	2 1/2	3 1/8	4	10	16	19 5/8	21 3/4
M.M.	51	64	79	102	254	406	498	552

IR LCN	APP BY	BAM 9/94
	DO NOT SCALE	
PULL SIDE / TOP JAMB MOUNTED NON-HANDED AUTO-EQUALIZER		
4810		