

ENTREMATIC

DITEC HA8-SP LOW ENERGY
DITEC FA8-SP FULL ENERGY

SWING OPERATOR Installation Manual

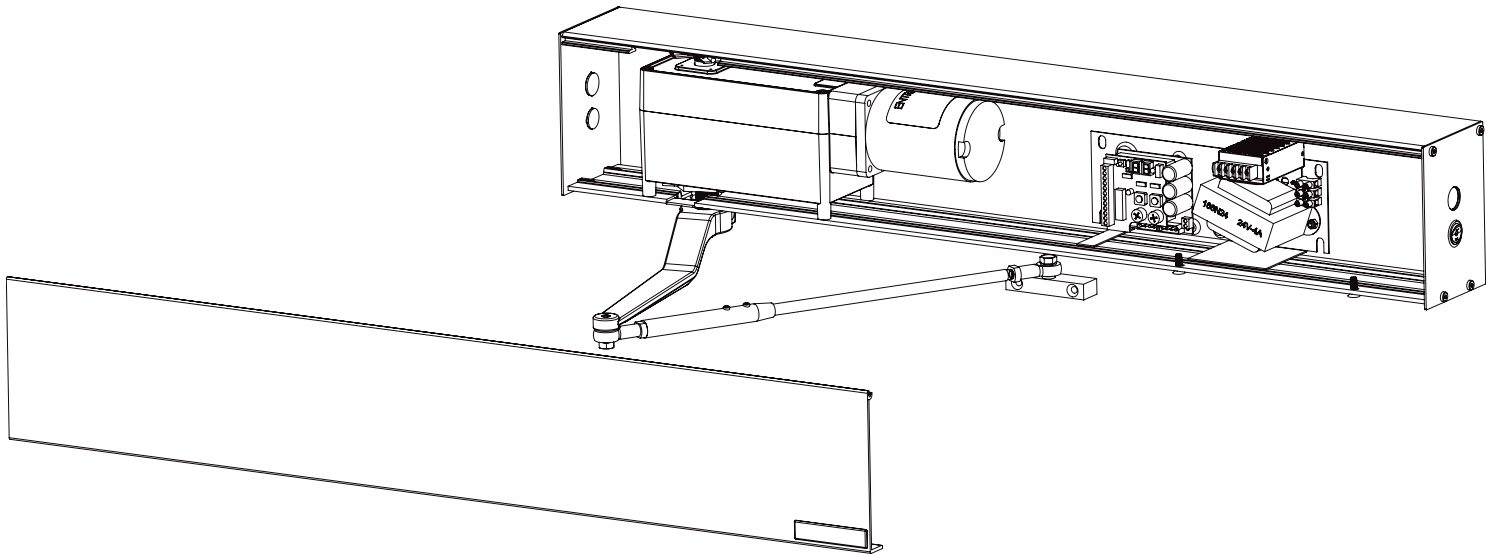

READ AND FOLLOW ALL INSTALLATION INSTRUCTIONS CAREFULLY!
FAILURE TO DO SO MAY RESULT IN PERSONAL INJURY OR PROPERTY DAMAGE!

Before Installation:

- Install only on a properly operating and balanced door. A door that is operating improperly could cause severe injury. Have qualified service personnel make repairs to cables, spring assemblies, and other hardware before installing the operator.
- Remove all pull ropes and remove, or make inoperative, all locks (*unless mechanically and/or electrically interlocked to the power unit*) that are connected to the door before installing the operator.
- If the operator has exposed moving parts, ensure it is out of reach from pedestrians.
- Do not connect the door operator to the source of power until instructed to do so. Connection of the high voltage supply should be done by a qualified professional and within the guidelines of the enforced local electrical codes.
- The technician must test all safety features before turning over the equipment to the customer.

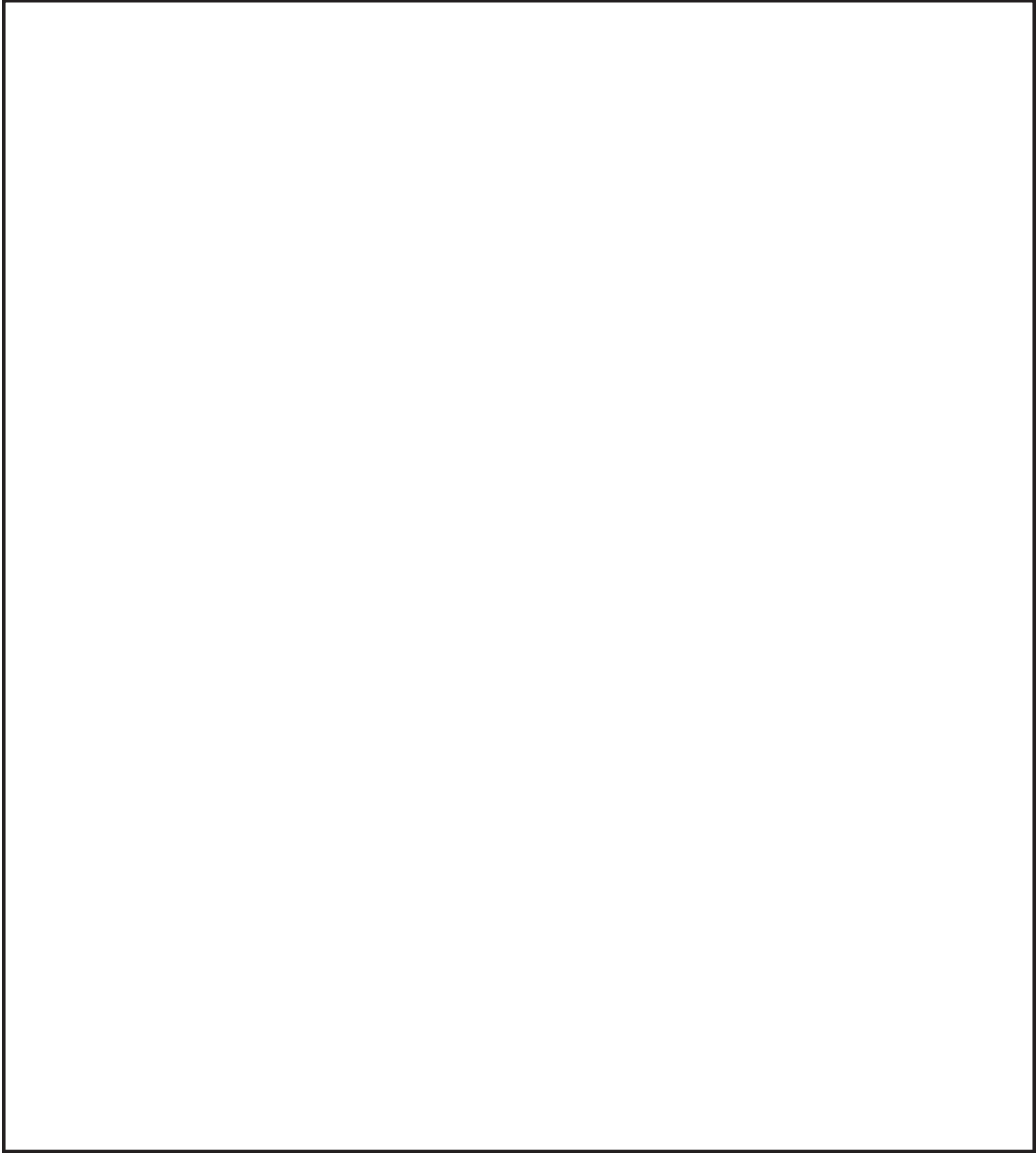

1.0 BEFORE INSTALLATION 6

- 1.1 Replacement Parts
- 1.2 General Information
- 1.3 Technical Specifications & Required Tools
- 1.4 Door Handings
- 1.5 Consideration of Surroundings
- 1.6 Electrical

2.0 OPERATOR INSTALLATION 12

- 2.1 Pre-Mounting Header Box Instructions
- 2.2 Operator Layout and Handing - Push and Pull
- 2.3 Double Egress Header
- 2.4 Gearbox Installation
- 2.5 Control Board Installation
- 2.6 Motor Drive Installation

3.0 ARM INSTALLATION 22

- 3.1 Push Arm
- 3.2 Pull (Z-arm)
- 3.3 Universal Arm - Pull and Push
- 3.4 Center Spindle (Concealed)
- 3.5 Center Hung

4.0 OPERATOR TUNING 37

- 4.1 Operator Factory Default Setting
- 4.2 How it Works
- 4.3 Back Check and Latch Adjustment
- 4.4 Spring Tension Adjustment

5.0 DOOR OPERATING MODE 49

- 5.1 Basic Operation
- 5.2 Operation Switch

6.0 DIGITAL BOARD & PROGRAMMING 50

- 6.1 Digital Board Specification
- 6.2 Connection Diagram - Low Energy (ANSI 156.19)
- 6.3 Connection Diagram - Fully Automatic (ANSI 156.10)
- 6.4 Programming Specification
- 6.5 Programming - Trouble Shooting
- 6.6 Safety Monitoring
- 6.7 Safety Sensor Connection - BEA Bodyguard
- 6.8 Safety Sensor Connection - BEA Superscan
- 6.9 Safety Sensor Connection - Optex OA-FLEX

7.0 DUAL DOOR PROGRAMMING 63

- 7.1 Dual Door Digital Board Specification
- 7.2 Wiring Diagram
- 7.3 Programming Specification
- 7.4 Programming - Trouble Shooting

8.0 ADA ADJUSTMENTS 70

9.0 INSTALLATION WRAP UP 71

- 9.1 Additional Components:
 - Sensor(s) / Knowing Act Devices
- 9.2 Header Cover
- 9.3 Safety Decals

10.0 MANUFACTURER INFORMATION 74

Step 1: Remove Header Cover
(Section 2.1)

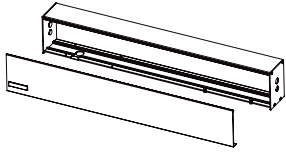

Step 2: Locate & Drill Power
(Section 2.1)

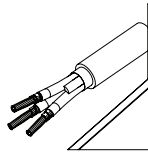

Step 3: Mount Header
(Section 2.1 - 2.3)

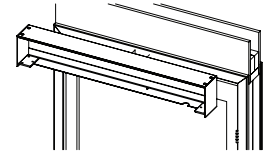

Step 4: Install Operator
(Section 2.4)

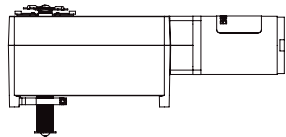

Step 5: Place Control Board
(Section 2.5 - 2.6)

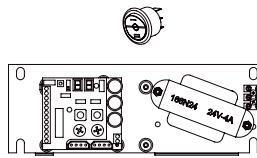

Step 6: Install Arm
(Section 3.0)

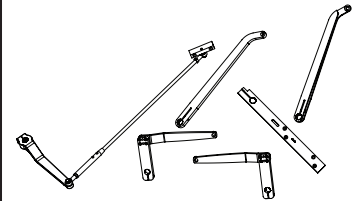

Step 7: Electronics Tuning
(Section 4.0 - 8.0)

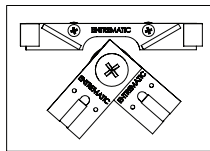

Step 8: Clean/close Header
(Section 9.0)

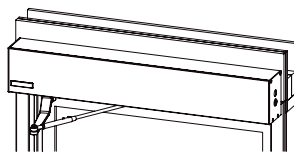

Step 9: Place AAADM Stickers
(Section 9.0)



Step 10: Install Sensor(s) / Knowing Act Devices
(Section 9.0)



Completed/Typical Automatic Door Installation

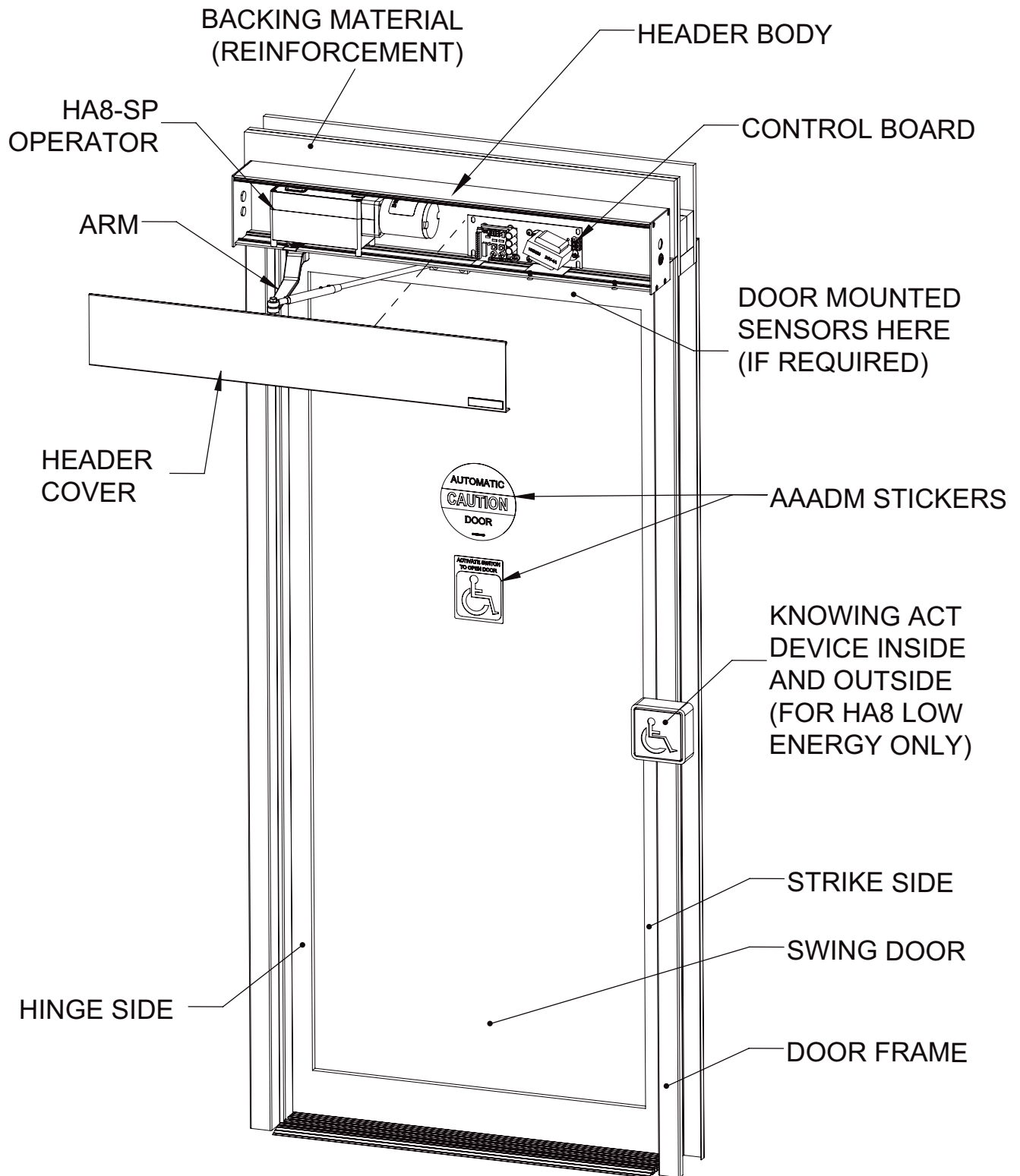

1.1 Replacement Parts

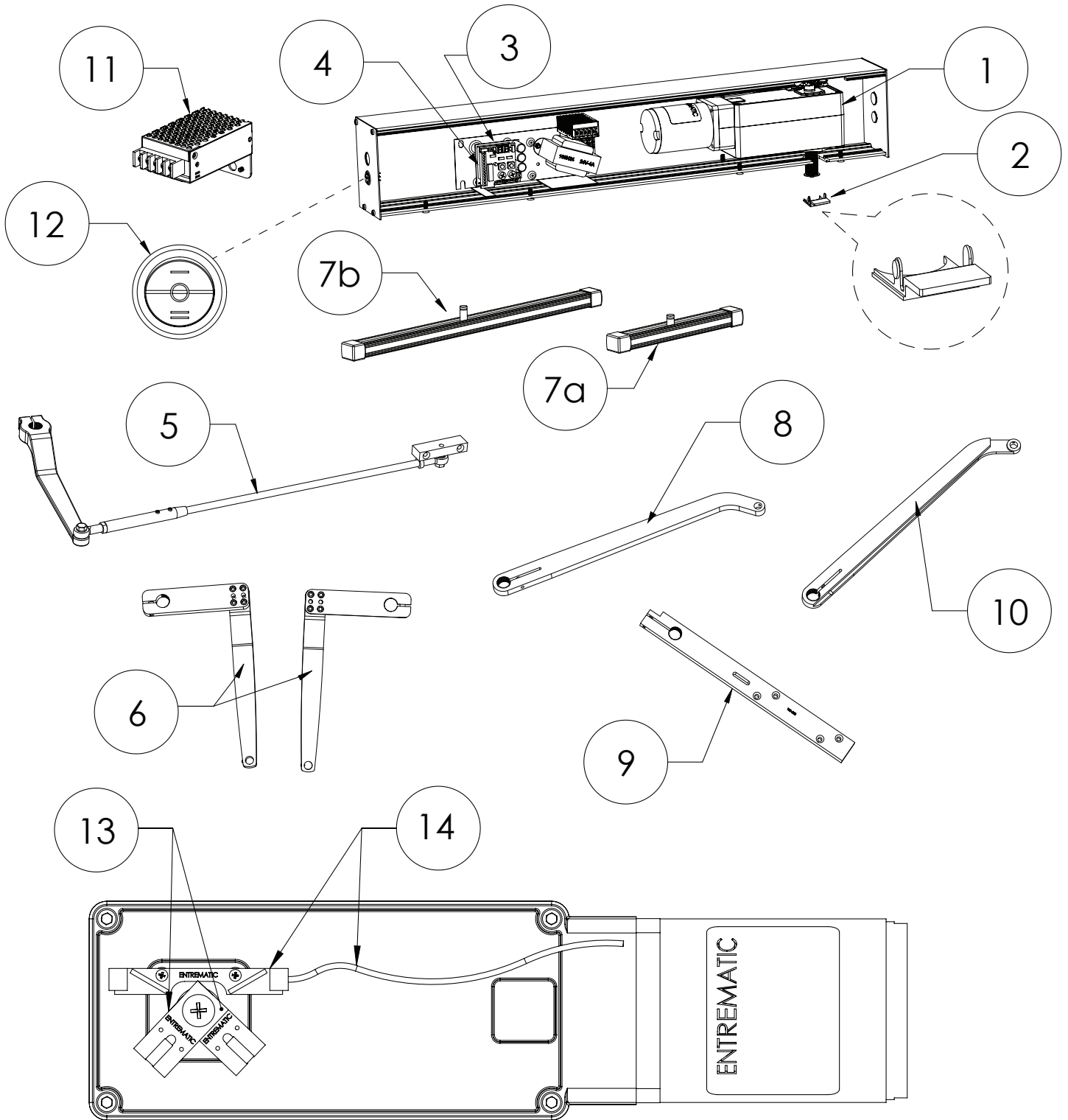

Replacement Parts

Item	Category	Part No.	Description
1	Operator	W7-105L	LH 1/8 hp Operator
		W7-105R	RH 1/8 hp Operator
		W7-107L	LH XP 1/4 hp Operator
		W7-107R	RH XP 1/4 hp Operator
		W7-106L	LH 1/8 hp Push & Go Operator
		W7-106R	RH 1/8 hp Push & Go Operator
		W7-108L	LH XP 1/4 hp Push & Go Operator
		W7-108R	RH XP 1/4 hp Push & Go Operator
2	Header Cap	W5-557	Header Plastic Cap
3	Control Board	W7-130-1	HA Digital Control Board
		W7-135-1	FA Digital Control Board
		W7-180	Dual Digital Control Board (FA8 only)
4	HA8 Fuse	W5-422	3AMP Fuse
	FA8 Fuse	W5-430	4AMP Fuse
5	Push Arm	W7-200	Complete Push Arm-Clear
		W7-205	Complete Push Arm-Bronze
		W5-502C	Cast portion only - Clear
		W5-502B	Cast portion only - Bronze
6	Z-Arm (Pull)	W5-506C	Z-Arm RH - Clear
		W5-505C	Z-Arm LH - Clear
		W5-506B	Z-Arm RH - Bronze
		W5-505B	Z-Arm LH - Bronze
		W5-508C	Extended Z-Arm RH - Clear
		W5-508B	Extended Z-Arm RH - Black
		W5-507C	Extended Z-Arm LH - Clear
		W5-507B	Extended Z-Arm LH - Black

Replacement Parts

Item	Category	Part No.	Description
7a	Pull Arm Track - Short (for Z-arm)	W5-550	Pull Track Assembly-Clear
		W5-555	Pull Track Assembly-Bronze
7b	Pull Arm Track - Long (for Universal Arm/ Center Spindle)	W5-551	Pull Track Assembly Long - Clear
		W5-556	Pull Track Assembly Long - Bronze
8	Universal Arm	W5-512C	Universal Arm - Clear
		W5-512B	Universal Arm - Bronze
9	Center Hung Arm	W5-520	Center Hung Arm 2 3/4"
		W5-521	Center Hung Arm 3 3/4"
10	Center Spindle Arm	W5-511C	Center Spindle LH - Clear
		W5-510C	Center Spindle RH - Clear
		W5-511B	Center Spindle LH - Bronze
		W5-510B	Center Spindle RH - Bronze
11	AUX Power Supply Kit (Optional)	WL-PWRKIT	RS-25-24 Power Supply Kit
12	Rocker Switch	WL-ROCKER SWITCH	ON/OFF/HOLD OPEN 3 position switch
13	Magnets Sets	W5-416	Detects Back check and Latch check phases
14	Reed Switch & Harness	W5-415	Communicates to Control Board the position of door

1.2 General Information

The HA8/FA8-SP Operator is a complete swinging door solution for push, pull, surface or concealed installations. The header contains the Driving system (Motor), Torque production (Gearbox), and a Control system to interlink the two.

The HA8/FA8-SP Operator ensures all-around safety. It can be combined with the full range of safety units, such as presence and motion sensors. It is easy to install for both new construction and retrofit applications.



- All wiring must conform to standard wiring practice in accordance with national and local wiring codes.
- Door must swing freely through the entire opening and closing cycle before beginning of installation. Typically, doors are hung on hinges 5" (127mm) max. width or 3/4" (19mm) offset pivots.
- An incorrectly installed or improperly adjusted door operator can cause property damage or personal injury. These instructions should be followed to avoid the possibility of misapplication or maladjustment.
- All dimensions are given in inches (millimeters), unless otherwise noted.

Templating Information

- Before installation, verify door frame is properly reinforced and is well anchored in the wall.
- Concealed electrical conduit, and concealed switch or sensor wires should be pulled to the frame before proceeding.

Suggested Fasteners for Frame

- #14 x 2-3/4" (70mm) long sheet metal screws for wood.

Suggested Fasteners for Door

- #12, #14, Wood screws, Sheet Metal screws, Self-tapping screws of varying lengths depending on applications.



The fastener components listed above are merely suggestions. A technician should use their best discretion to determine what components they'll need to complete the job.

Shipping Inspection

Verify that the order was shipped complete and correct, including model number, door swing, color, and header width.



- The gearbox housing has the swing hand (L or R) labelled on the exterior housings.
- If any of the above items are not correct, do not attempt to install until all conditions are correct.
- Report any incorrect items to the general contractor immediately.



NO CLAIMS FOR SHORTAGE WILL BE ALLOWED UNLESS REPORTED WITHIN 24 HOURS OF RECEIPT OF SHIPMENT.

Safety Precautions

- Do not climb or put weight on any door or header parts
- Do not let children play with the operator or the electrical board
- Keep remote controls away from children
- Keep all power off to the unit, when performing any work or maintenance

To avoid bodily injury, material damage and malfunction of the product, the instructions contained in this manual must be strictly observed during installation, adjustment, repairs and service etc. Training is needed to carry out these tasks safely. Only Entrematic-trained technicians should be allowed to carry out these operations.



It is the responsibility of the final installer and/or installation company, to certify that the final completed operator is installed in accordance with local building codes and applicable laws.

1.3 Technical Specifications & Required Tools

Model	Ditec HA8-SP
Dimensions	4.5" W x 6.5"H
Weight	Approx. 45 lbs
Power Supply	115 ± 5VAC, 60Hz, 3A
Consumption	DC16V/ 3 AMP, DC24V/ 3 AMP
Motor	1/8 hp, 24VDC/16VDC, 3A (Standard), 1/4 hp, 24VDC/16VDC, 3A (Optional)
Rated Operation	Continuous opening and closing cycles
Manual Opening/Closing Force - <i>during power failure</i>	15 lbs
Door Opening/Closing Speed & Force	Adjustable, see section 8.0 ADA ADJUSTMENTS
Operation - <i>during power failure</i>	Low manual resistance when opened by hand. Door closing by spring.
Hold Open	Pulsed Energy to Motor. No overheating. Continuous Hold Open
Operating Environment	Ambient temperature -4F to +120F (-20C to +50C) <i>No condensation or icing</i>
	Ambient humidity 30% to 85% RH <i>(No hazardous materials must be present in the atmosphere)</i>

Required Tools for installation:

- | | |
|------------------------------|----------------------------------------------|
| • Allen Wrench Set | • Screwdrivers: Flat, Philip, 5/16" Hex. Nut |
| • Power Drill and Drill Bits | • Additional Fasteners Depending Surface |
| • Level | • Shims |
| • Tape Measure | • Hand Saw/ Power Saw |
| • Wire Stripper | |

1.4 Door Handings

The handing and types of each operator are shown in the figure below; the black dot indicates the spindle location. The HA8-SP operator can be used for all installations.

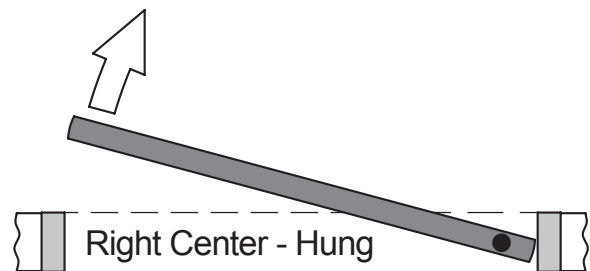
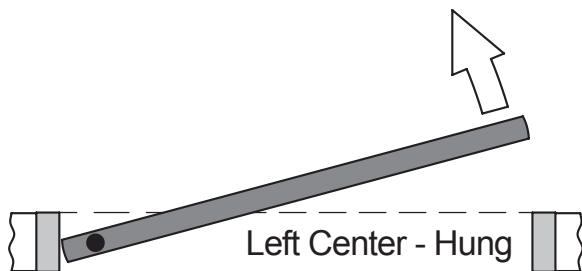
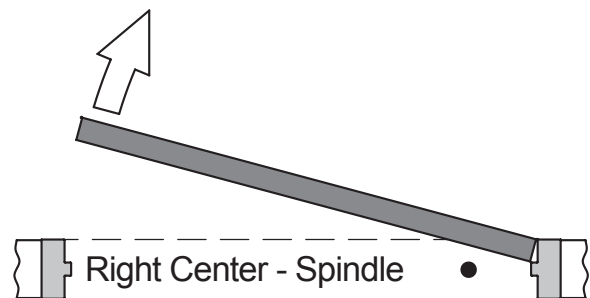
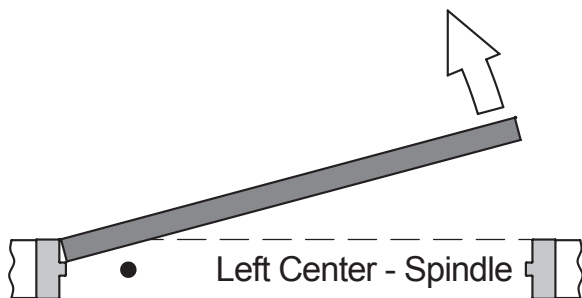
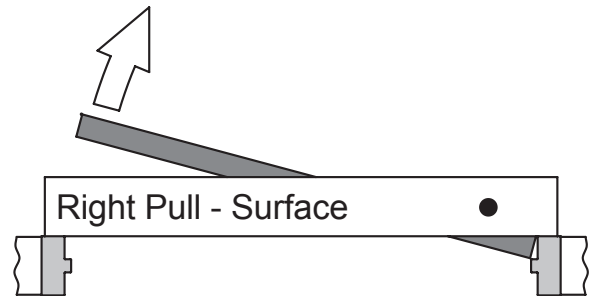
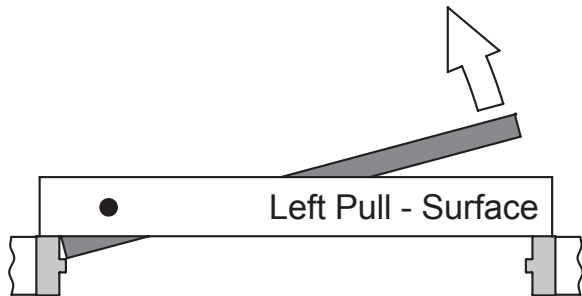
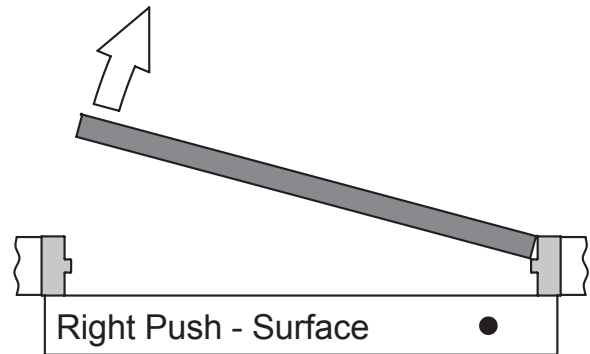
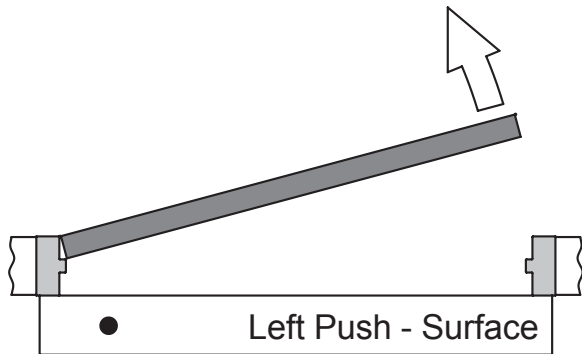

1.5 Consideration of Surroundings

Floor Space Requirements for Wheel Chair Maneuvering - Americans with Disabilities Act (ADA)

The owner may request the activation device location; however, the press switch must be in view of the door and not directly on the door or frame. Please refer to ANSI 117.1 Safety Code for further guidelines on switch requirements.



Activation switches shall be at minimum height of 36" and maximum height of 48" from finished floors. Individual who uses wheelchair needs a minimum of 48" clearance to the door swing for doors in series.

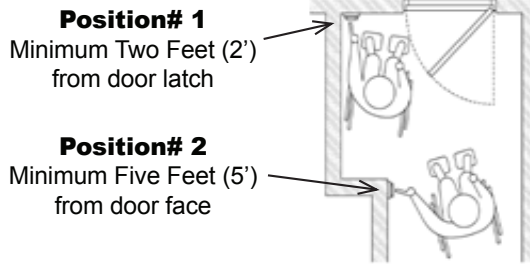

External and Internal Factors

Door Condition	Door must move easily open and close (latch) without excessive force; weather stripping and threshold must not interfere with door movement.
Reveal	For out swing (Push) doors, the reveal must be within the range of 0" to 14". For in swing (Pull) doors, 0" to 4" for special reveals is allowed – for all others consult factory.
Wind	When installing on a door in a strong wind condition area, special adjustments should be made to the arm and doorstop position, to increase the spring tension.
Power/Control Wires	Check that the electrical feed, all conduits, and electrical junction boxes (for push plates or other activation devices, if required) are correctly located in accordance with final approved shop drawings and within the guidelines of the enforced local electrical codes.

1.6 Electrical

The 115±5VAC supply lines are connected to the **black primary wires coming from the transformer** and the ground wire is attached to the operator header box. Mount the ON/OFF/HOLD OPEN switch in the header end plates to the latch side of the unit (or closest to the control board).

The control board settings have been pre-set prior to shipment. It will be necessary for the door operator to be functional while adjustments and settings are made. A black push actuator is mounted on the upper left corner of the circuit board to ease in the adjustment process. Power up the unit, push an activating device and check to make sure that the spline pinion drive rotates in the correct direction. Keep all wires away from moving parts and sharp edges that may cut into the outer casing of the wires.



THE GROUND WIRE FOR THE INCOMING 115±5VAC POWER AND THE SYSTEM GROUND WIRE CANNOT SHARE THE SAME GROUNDING STUD. GROUND THE INCOMING 115±5VAC ACCORDINGLY.

- Installation of any extra wiring for controls or accessories into the header unit shall be secured and away from any moving parts.
- If the motor is not plugged into the circuit board, there is no resistance against the spring when manually opening the door. The door or arm will close very quickly if opened.

2.1 Pre-Mounting Header Box Instructions

Power supply may be pulled into the header at the same time the header assembly is positioned. Make sure all power is turned off before handling the supply wires. This should be done by a certified electrician and within the guidelines of the local electrical codes.

Be sure there is proper support in the wall to secure the header at the vertical jambs, and behind the header at intervals between the vertical jambs. Secure the header to the top of the door frame with the appropriate fasteners as indicated below. The header is a 2 piece box consisting of the body (portion anchored to the door frame) and the cover (removable portion used during installation and service). Remove the header from its packaging and place it on a protective surface. To remove the cover, please follow the steps below.

STEP 1

Remove 2 Machine Screws #1/4-20 x 3/4" anchoring the cover.

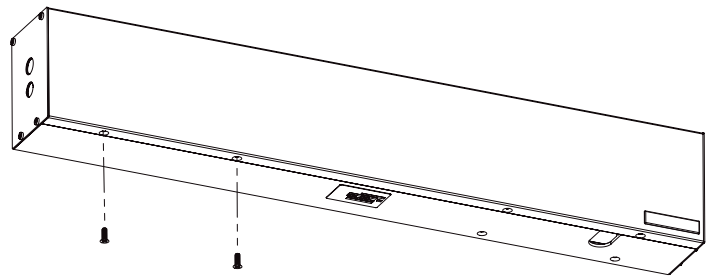

STEP 2

With the screws removed, the cover should be able to be lifted up and outwards with minimal effort. Carefully, set the cover in a location where it will not be damaged.

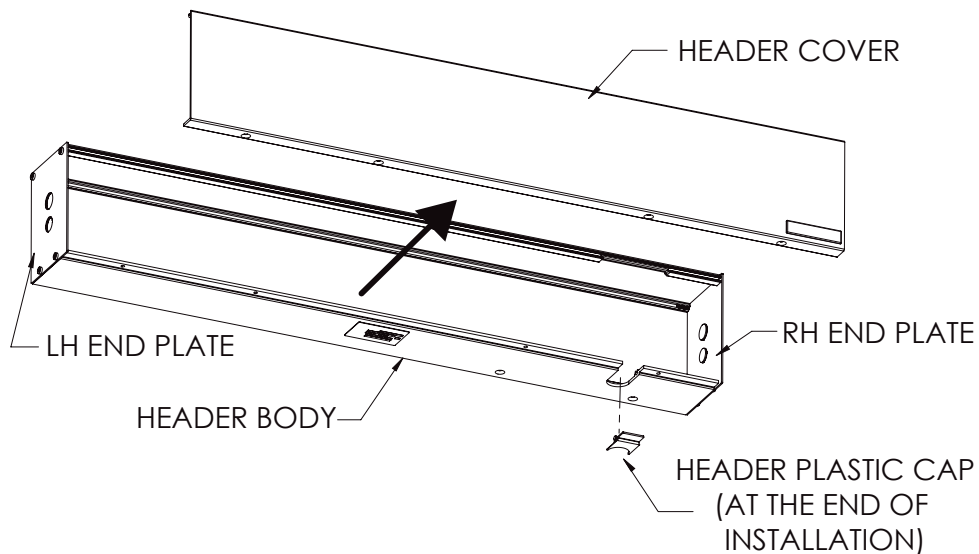

- All holes should have any sharp edges and burrs removed; ensure electrical bushing is used.
- If operator is installed on aluminium framing high and low voltage wiring can be routed through vertical and horizontal tubes.
- Please reference the installation dimension 1.5 inches from the hinge side of the door.

The following figure illustrates the optimum location for low and high voltage wiring feeds. Place the body portion of the header on the door frame, mark hole locations for high and low voltage wiring and drill holes.

Knock out the hole on the end plate for the operator ON/OFF/HOLD OPEN switch on the header body (usually on the strike side).

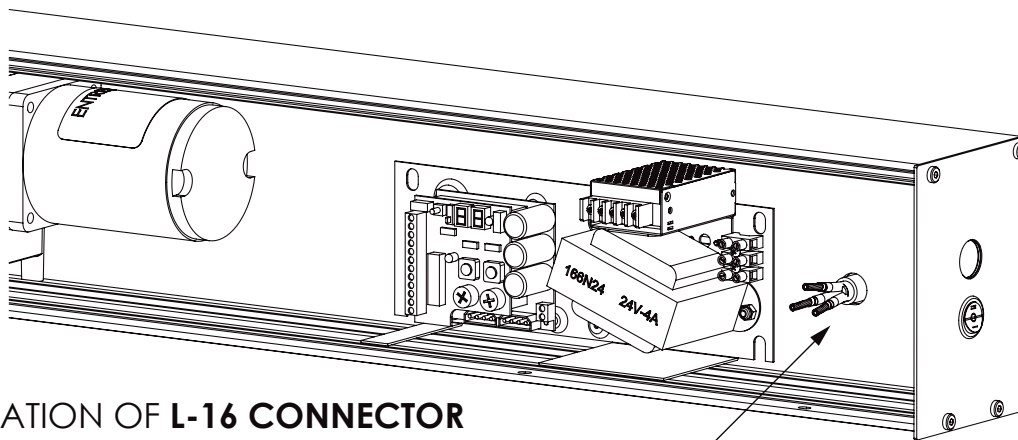
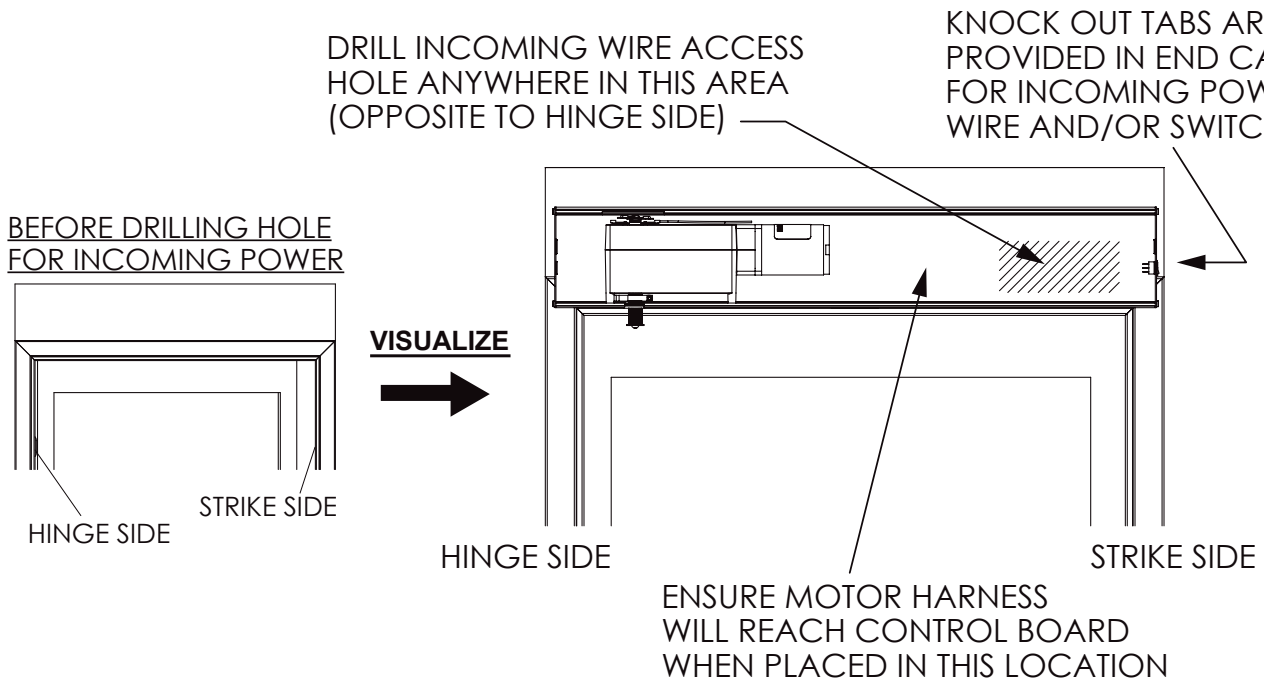

INSTALLATION OF L-16 CONNECTOR FOR ARMoured (BX) CABLE/ INCOMING POWER (TO SECURE LINE TO HEADER) IS RECOMMENDED

TYPICAL THROUGH-HOLE INSTALLATION

MOUNTING HOLES CAN ALSO BE PLACED ON END CAPS DEPENDING ON SITE CONDITIONS

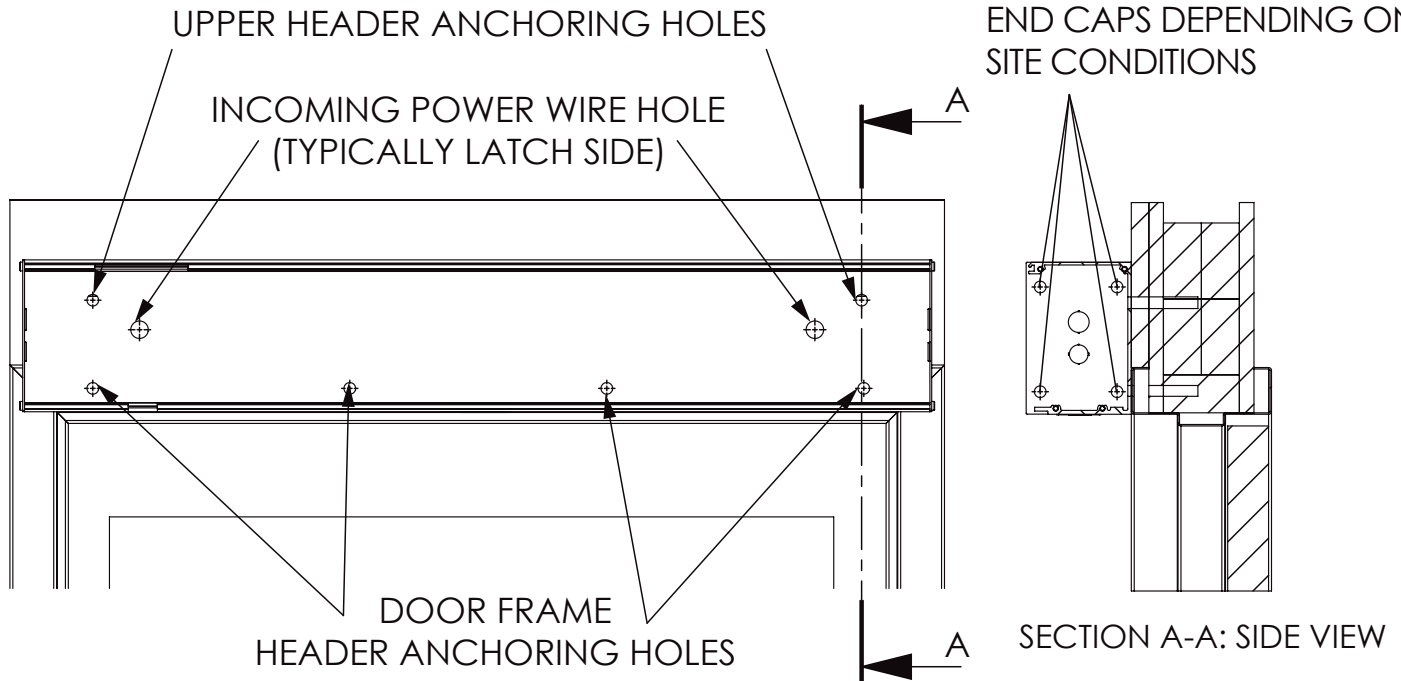

- Holes can be made anywhere in header to secure.
- All holes must be drilled into substantial support (studs, blocks, framing, etc.)
This may not reflect your installation.

2.2 Operator Layout and Handing

A summary of Push and Pull operators is shown in the image below.



Holes can be made anywhere in Header to secure to the wall. All holes must be drilled into substantial support (studs, blocks, framing, etc.). This may not reflect your installation.

HORIZONTAL SECTION

PUSH-STYLE OPERATOR

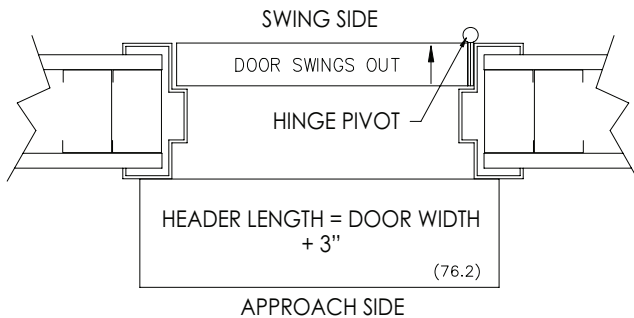

PULL-STYLE OPERATOR

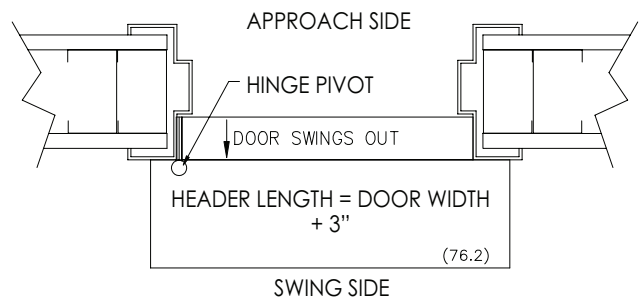

VERTICAL SECTION

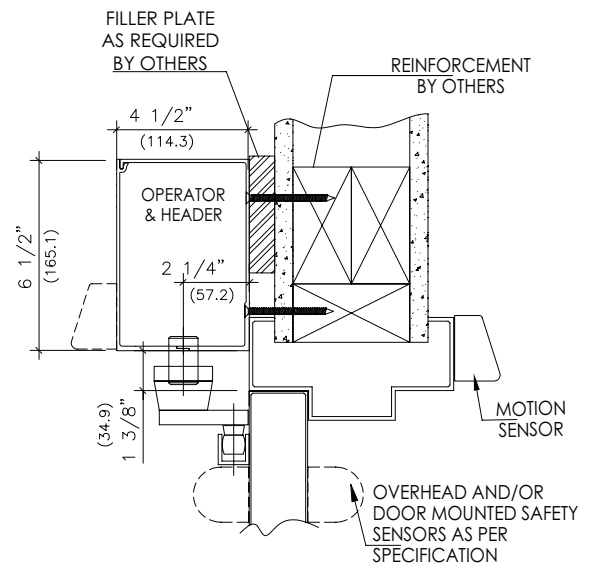
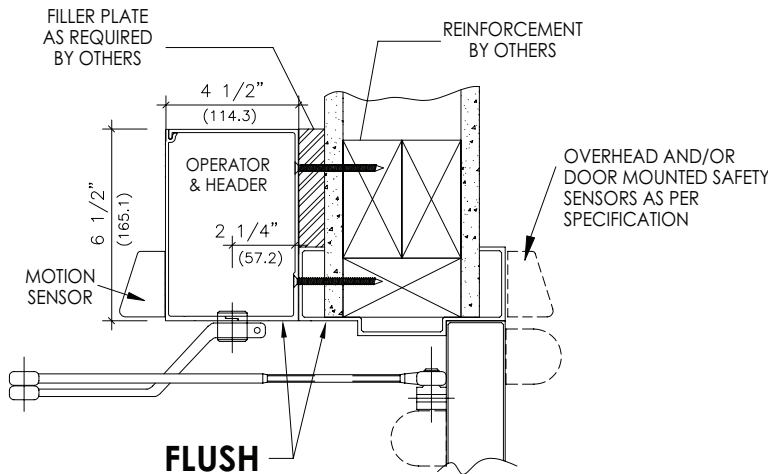

For Universal Arm application, please see section 3.3

Push Header

The Header Box on push installations is mounted flush to the bottom of the doorjamb header. It may require solid backing material to compensate for the thickness of the door frame. Before fastening header box to the door frame, ensure that your access holes for high and low voltage wires match. Header box should be referenced to the hinge side of the door. For most applications, the header is equal to door opening plus 3". This allows for a 1½" space on either side of the Header Box to anchor the header box properly to the frame. The header box should be anchored with a minimum of (6) six #14 x 1" Pan Quad Type A screws (provided.)

- The locations of the screws on the header will be application dependant.
- Fasten the header body as application requires. The header should support 200lbs.



- Header **MUST** be installed 1.5 inches from hinge side for all Push/ Pull installation, regardless of whether header is sized appropriately to door opening.

IDEAL APPLICATION SHOWN:

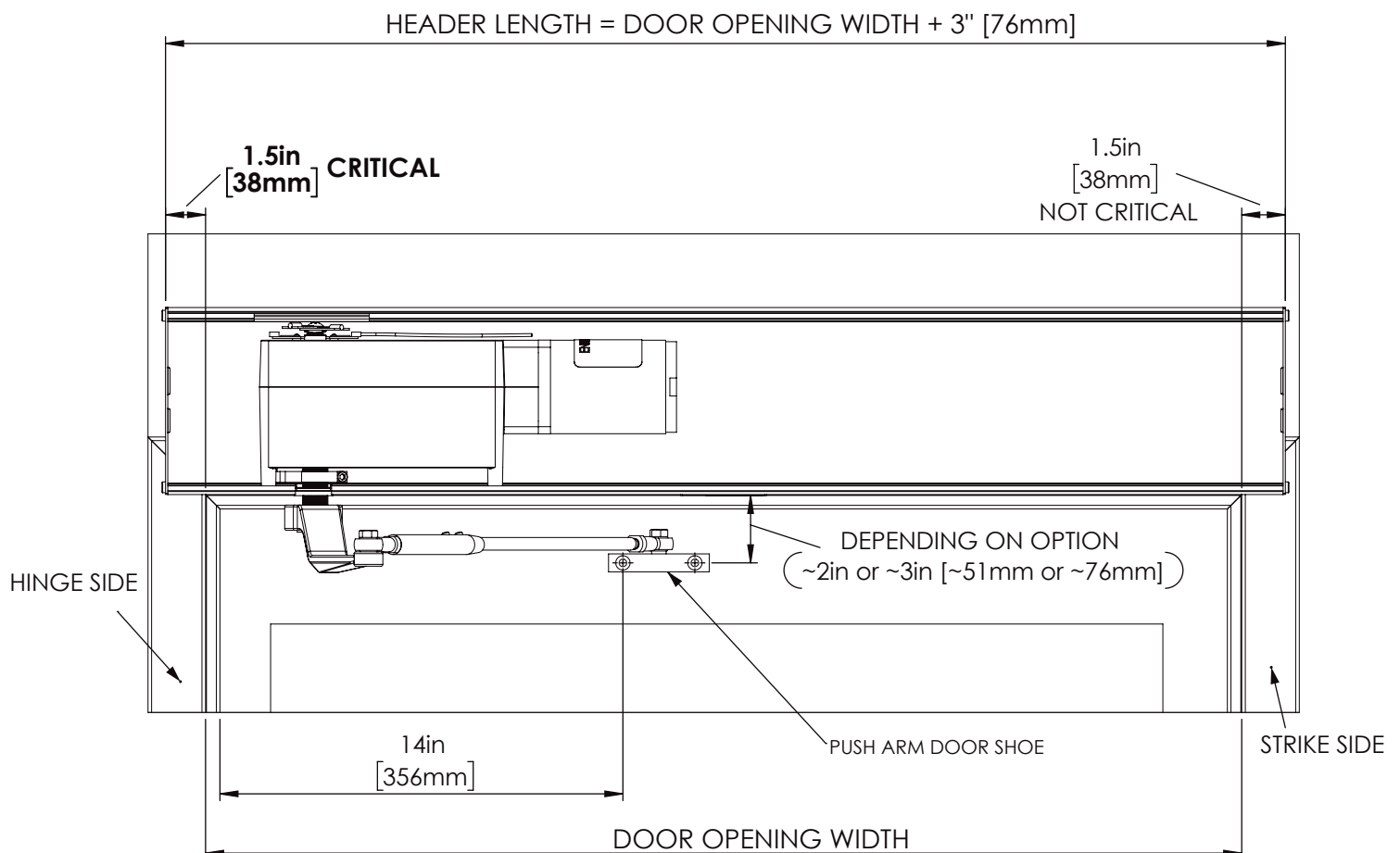

Pull Header

Ensure before fastening header box to the door frame that your holes for high and low voltage wires match. Header box should be referenced to the hinge side of the door and 1 3/8" above the bottom of the door frame (see figure below). For most applications, the header is equal to the door opening plus 3". This allows for a 1.5 inch space on either side of the header box to anchor the header box properly to the frame. For correct sized header, the header box should be anchored with a minimum of (6) six #14 x 1" Pan Quad Type A screws (provided), but will also depends on what is being screwed into.

- The locations of the screws on the header will be application dependant.
- Fasten the header body as application requires. The header should support 200lbs.

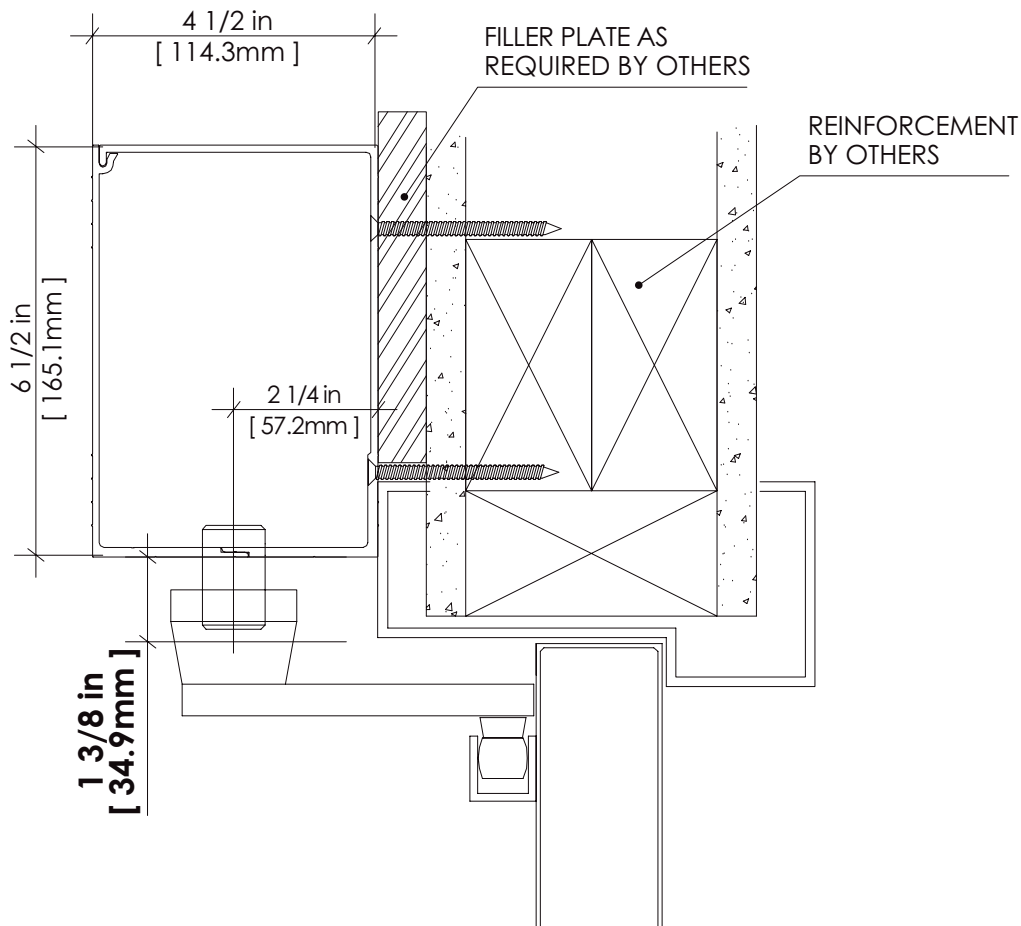

- Header on pull applications must be mounted so the main drive pinion safety washer and machine screw are above the top of the door. This is to ensure the spindle does not obstruct the swing path of the door.
- For application with Universal Arm, Header will be installed differently. See section 3.3.

2.3 Double Egress Header

Double Egress operators has Pull type and Push type operator in the same housing, the header must be mounted 1 3/8 inches above the door frame. For Push type operator, arm clearance issues may arise. To ensure the arm clears any existing doorstops, mount the arm according to the diagram below marked PUSH CONFIG.

See Section 3.1 to change the Push arm configuration.

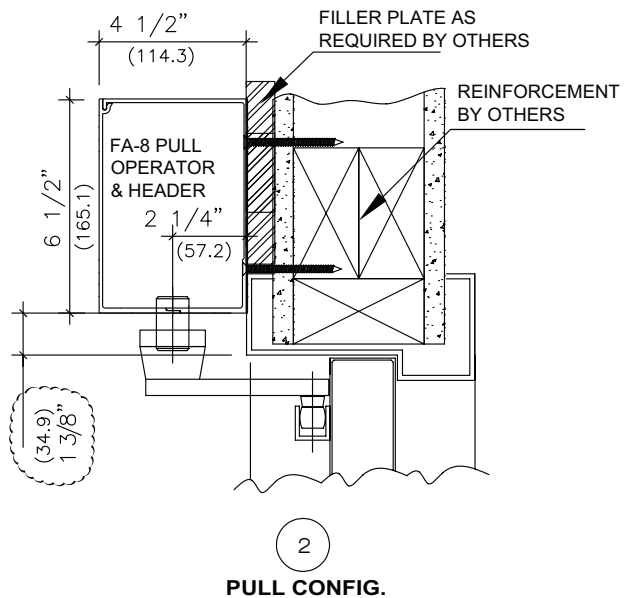
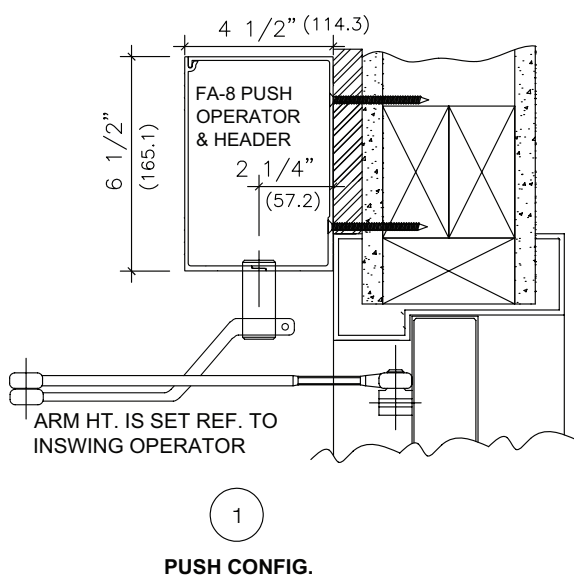
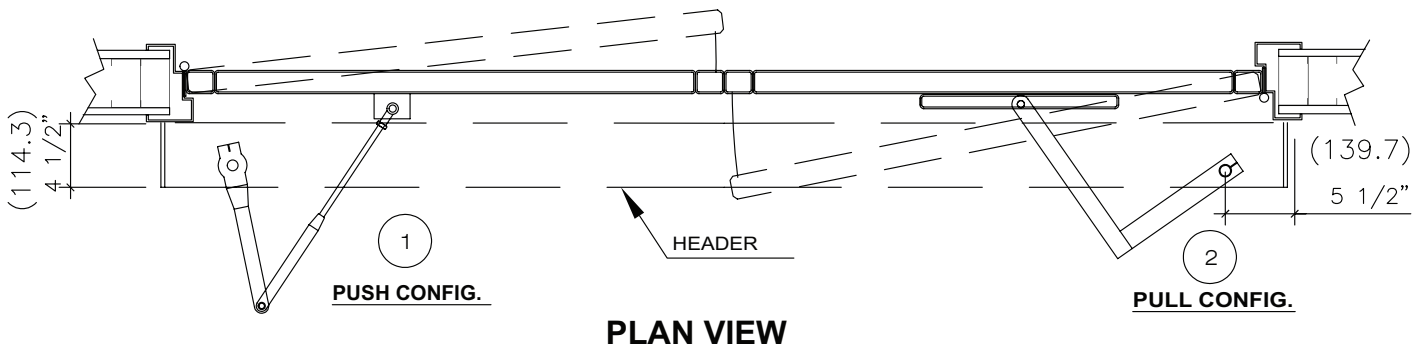

VERTICAL SECTION



For Push application, the long spindle is provided.

2.4 Gearbox Installation

STEP 1

Place the gearbox into the header, according to the handlings shown in Section 1.4. The output shaft of the gearbox (spindle) must fit in the corresponding slot at the bottom of the header.

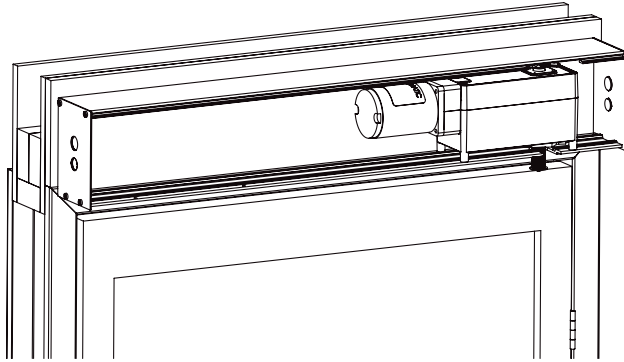

HEADER BODY IS NOTCHED OUT TO PROTECT REED SWITCH AND LIMIT SWITCHES DURING INSERTION

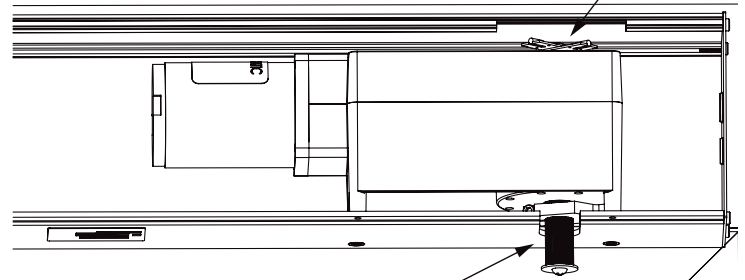

ALIGN SPINDLE TO HOLE

STEP 2

While holding the operator, line up the (2) two furthest feet of the bottom housing of the cast gearbox, with the corresponding holes in the header. These holes will secure the gearbox onto the header.

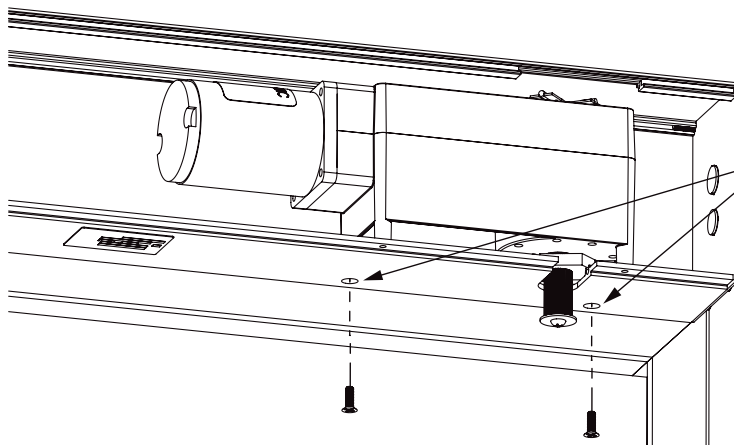

LINE UP GEARBOX FEET HOLES TO HEADER HOLES AND SCREW IN (2) 1/4"-20 x 3/4" FLAT QUAD MACHINE SCREWS (ZINC PLATED), PROVIDED IN OPERATOR SCREW PACK

STEP 3

Screw one (1) Flat Quad Zinc Plated machine screw #1/4-20x3/4" into each indicated holes from above, to secure the gearbox onto the header.

2.5 Control Board Installation

Place the board in the header beside the motor of the gearbox. The control board will be on the opposite side of the gearbox motor. For example, in a right hand (RH) operator, the control box is on the left of the gearbox motor. There is no need to secure the board in place, due to the provided mounting bracket.

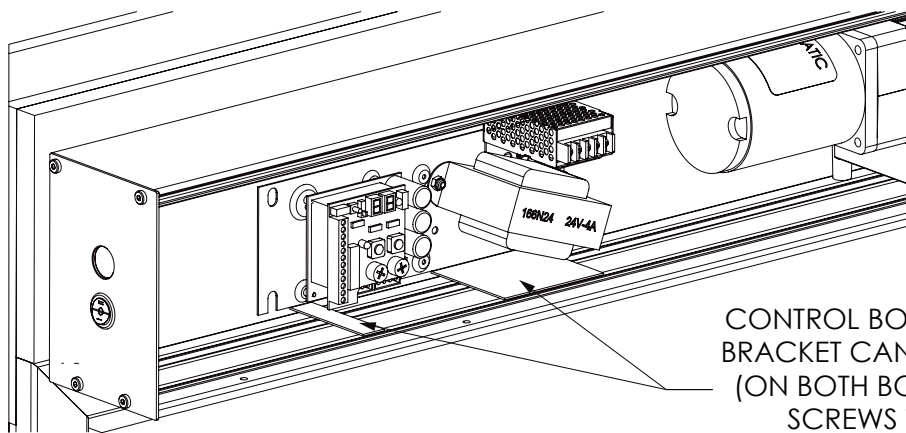
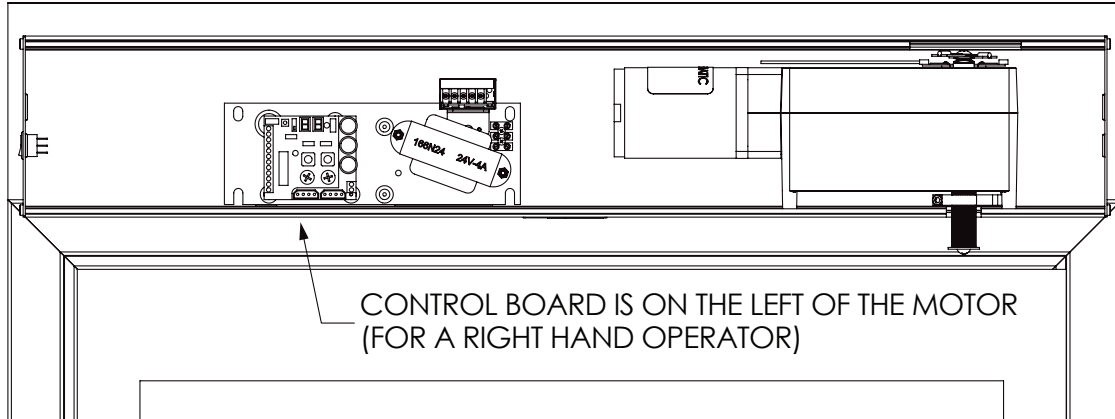

CONTROL BOARD BRACKET
CAN STAND FREELY OR BE
MOUNTED TO THE WALL USING
ANY APPROPRIATE MEANS
(i.e. DOUBLE SIDED TAPE, SCREW, ETC.)

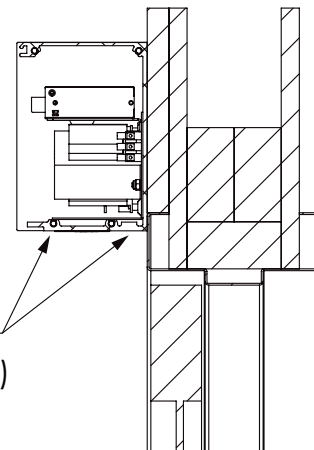

Grounding wire of the transformer will require a separate screw.

2.6 Motor Drive Installation

Connect the Motor wire leads (large four pin), the Back Check and Latch wire lead (small three pin) to the top of the board. Motor is plugged in the **Right Terminal** for right hand swing, **Left Terminal** for left hand swing.

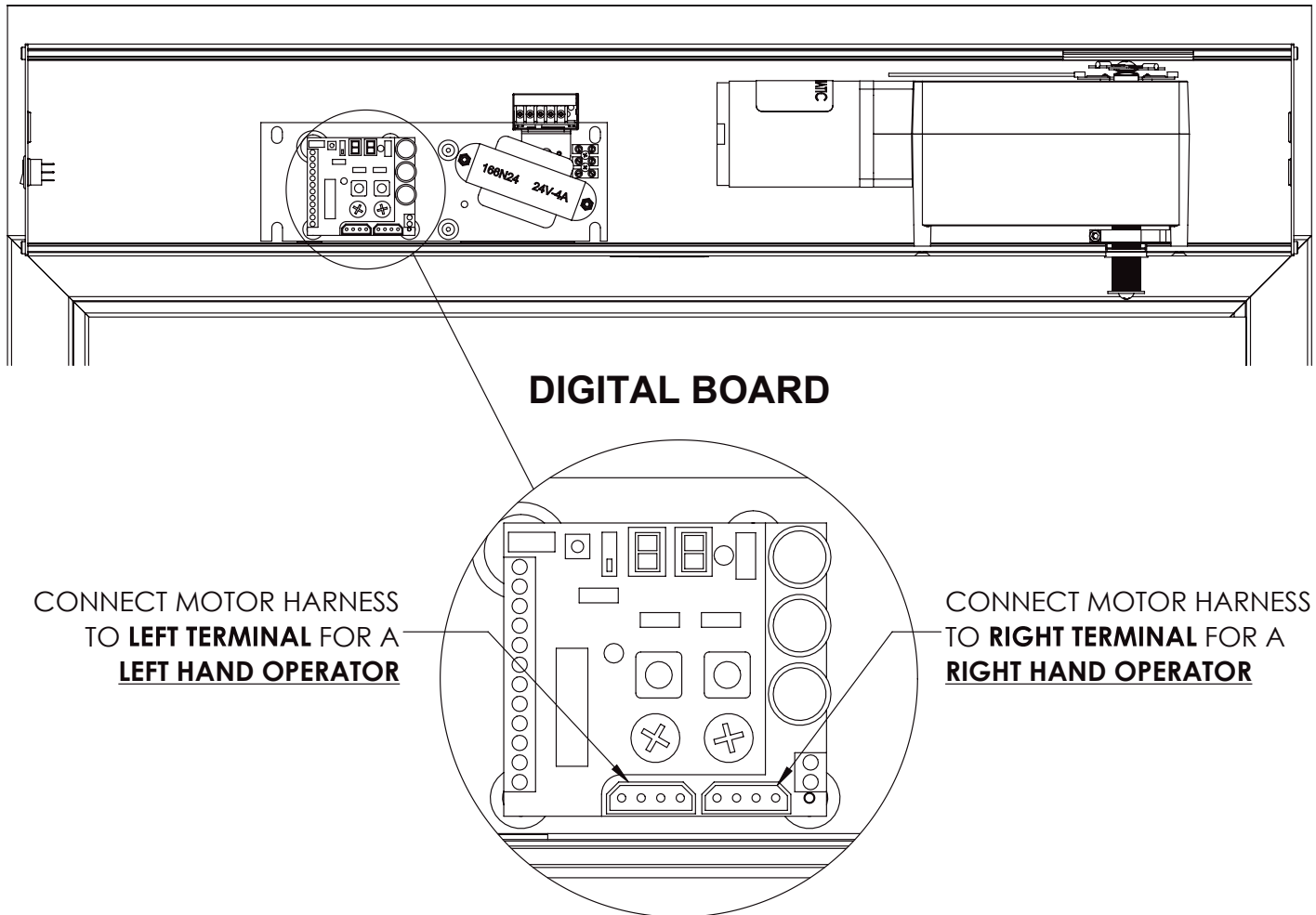

WARNING!

If the motor is not plugged into the circuit board there is no motor resistance against the spring when manually opening the door. The door or arm will close very quickly if opened, which could cause harm to pedestrians!

3.1 Push Arm Components & Configurations

The main arm components will consist of the **Main handle**, **Sleeve**, **Adjustable rod** (cut to length), and **Door shoe**, as shown below.

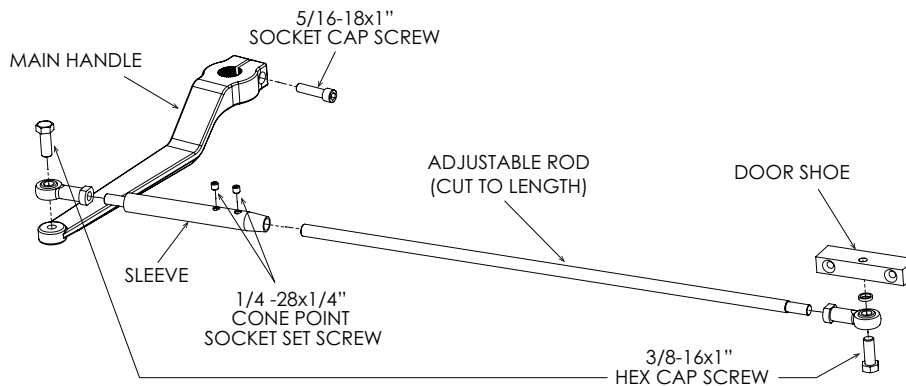

There are two configurations available depends on available spacing.

Option 1 - Standard Configuration

This is the standard configuration for the Push arm, the Sleeve and Rod are above the Main handle. Use this configuration when there is no issue with clearance between the Rod/Door shoe and top jamb of the door frame. The Rod and Sleeve are flexible at the ends where they are bolted (semi-ball joint) which will provide additional flexibility during install.

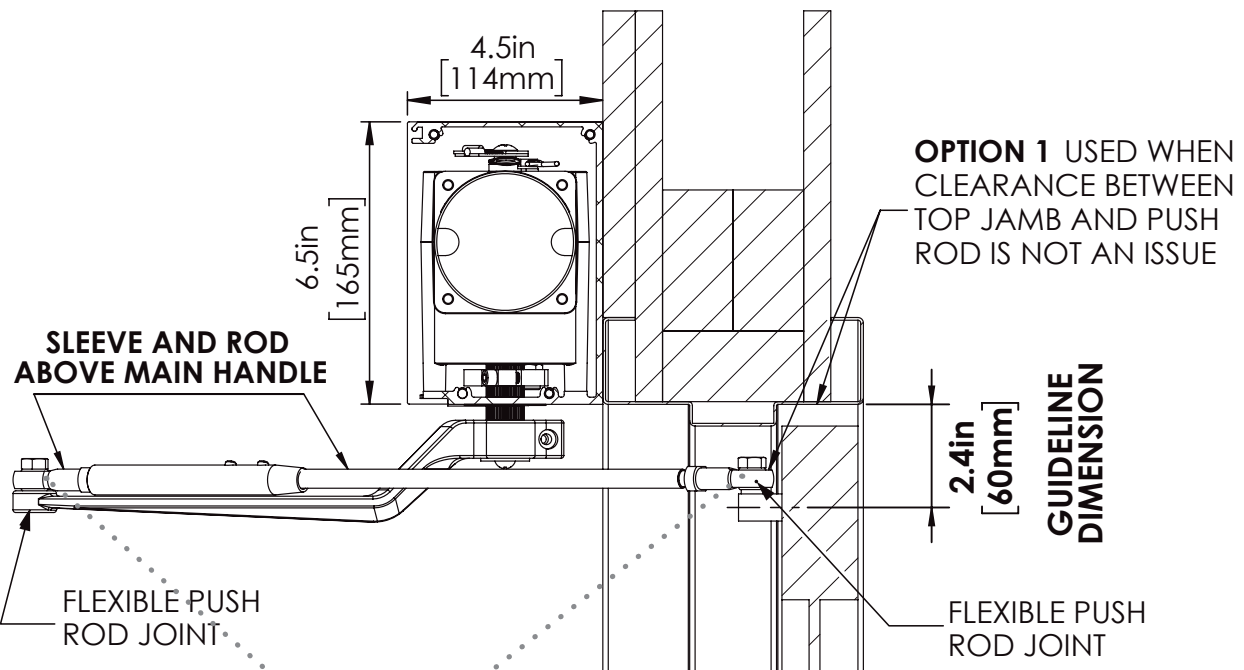

WARNING!

Please ensure Shoe Bolts at these joints are tightened after installation of arm is complete.

Option 2 - Double Egress Configuration

For this option, Sleeve and Rod are below the Main handle. Use this configuration when the clearance between the Rod/Door shoe and the top jamb (or any other obstruction in the swing path) prevents **Option 1** from being properly installed. With this option, an approximate 1 inch in vertical space is gained. This configuration also uses on Double egress headers, where there is a pull arm and a push arm installed. The Rod and Sleeve are flexible at the ends where they are bolted (semi-ball joint) which will provide additional flexibility during install.

Used when clearance is an issue, an extra inch or more is added for installation.

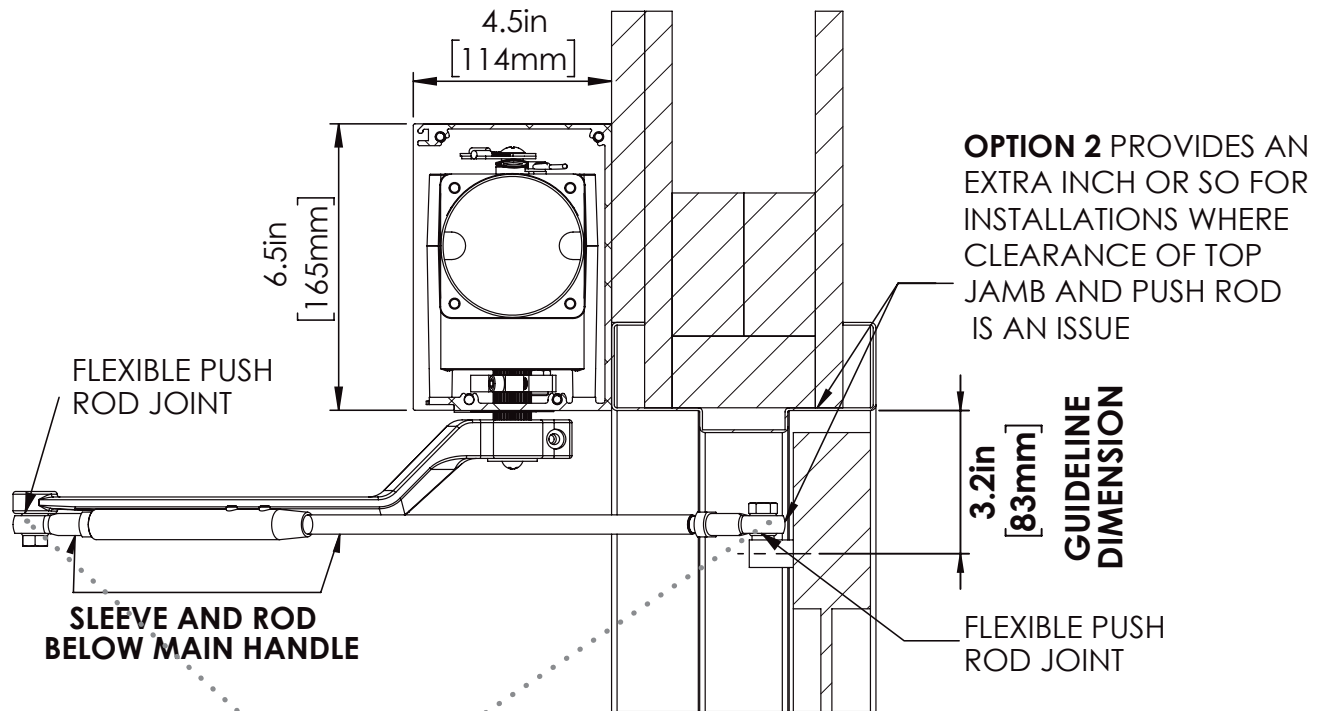

WARNING!

Please ensure Shoe Bolts at these joints are tightened after installation of arm is complete.

STANDARD DOOR SHOE MOUNT

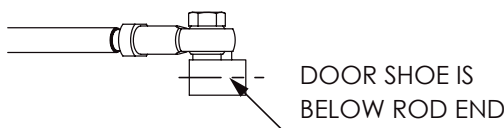

ALTERNATE DOOR SHOE MOUNT - REVERSED

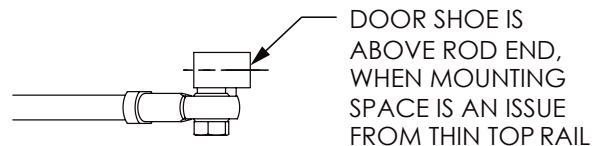

Note that the rod is shown above the door shoe when installed, so that if the bolt ever loosens it will not fall down via gravity. Should the door rail you are attaching to have a thinner horizontal top rail, the door shoe can be reversed to be above the rod end if space permits.

Push Arm Installation

STEP 1

Keep the door in close position,

Install Door shoe 14 inches to first hole from hinge side and 2 ¼ inches from top of door.

Attached Rod to door block. Fit Main handle and Sleeve on drive shaft (spindle) at 80 degrees to the door latch.

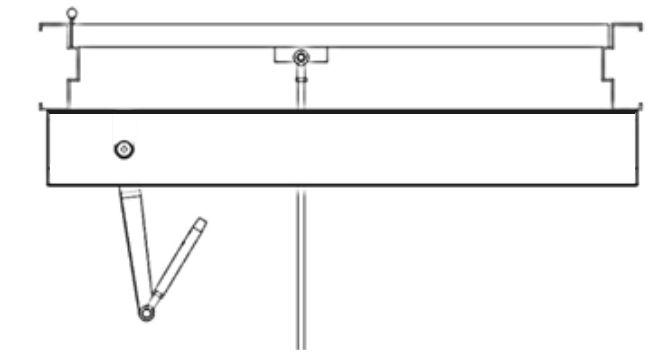

STEP 2

Line up Rod with Sleeve and mark 1 inch past 2nd set screw and cut

Insert Rod fully into Sleeve. Tighten set screws.

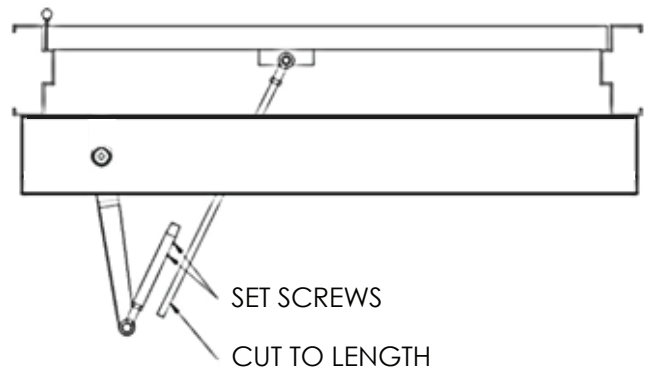

STEP 3

Arm is now fully assembled and fixed to the Door shoe on door panel & drive shaft.

Remove Main handle from drive shaft, and set operator switch to Hold Open. Allow the drive shaft to turn fully until hitting the built-in door stop.

Assemble Main handle to the drive shaft and tighten. If needed, loosen set screws for minor adjustment of door position.

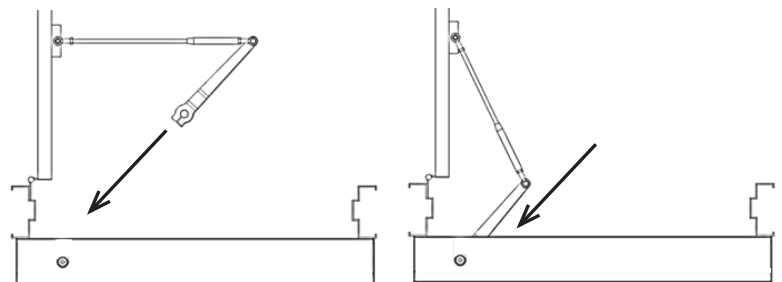

STEP 4

Set operator switch to Automatic and allow door to close under spring pressure. Test and adjust if necessary.

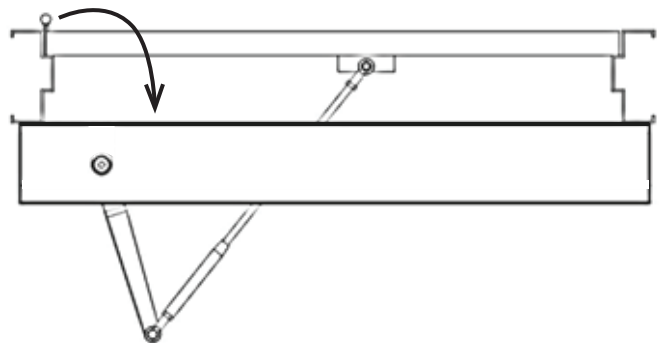

3.2 Pull Arm (Z-arm) Installation

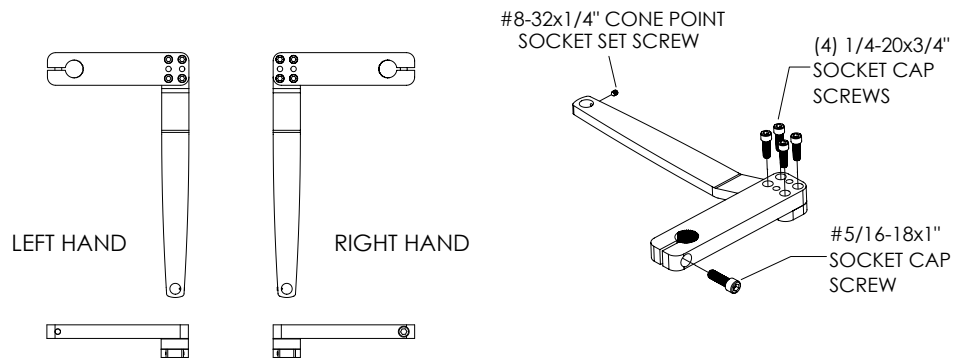

LEFT HAND PULL

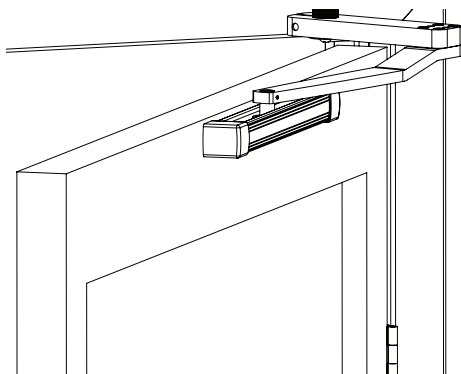

RIGHT HAND PULL

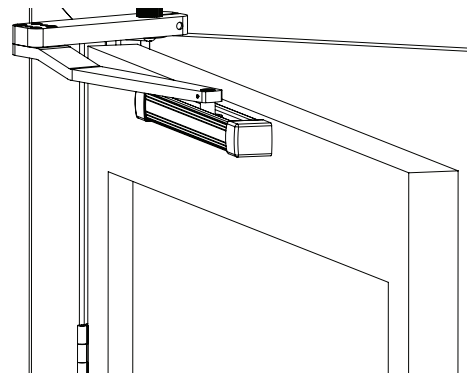

STEP 1

Set operator switch to Hold Open. The drive shaft (spindle) will turn until hitting the internal doorstop.

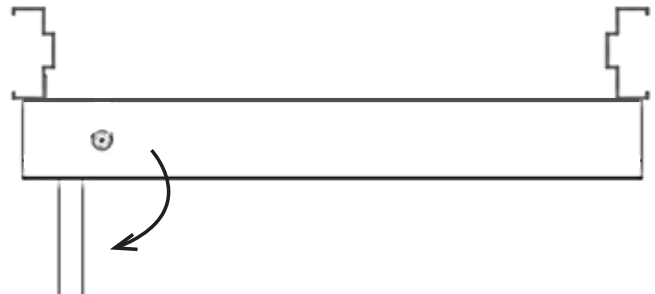

STEP 2

Keep the door in full open position

Fit Z-Arm to the drive shaft (spindle) at the full open position and tighten. Mark open position where roller touches door.

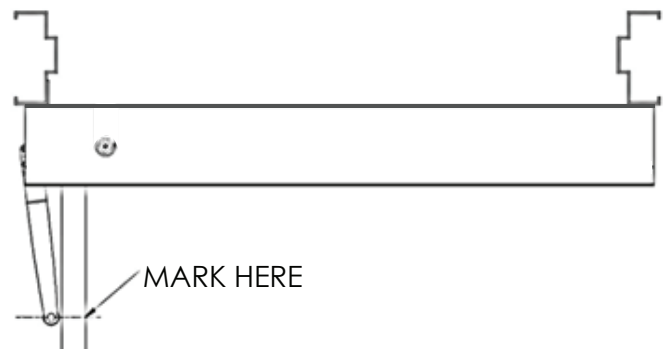

STEP 3

Set operator switch to Off and allow door to close under spring pressure.

In closed position, place mark where roller touches door.

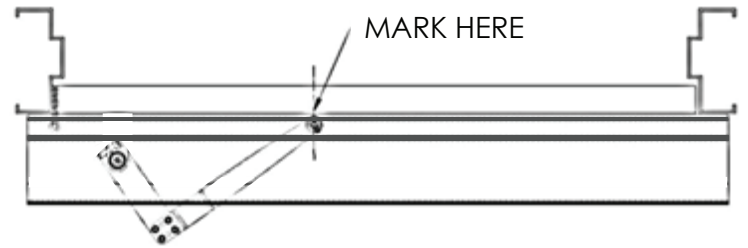

STEP 4

Fit Pull track in line with 1st and 2nd mark and fix to the door. Turn operator switch to Automatic.

Test and adjust if necessary.

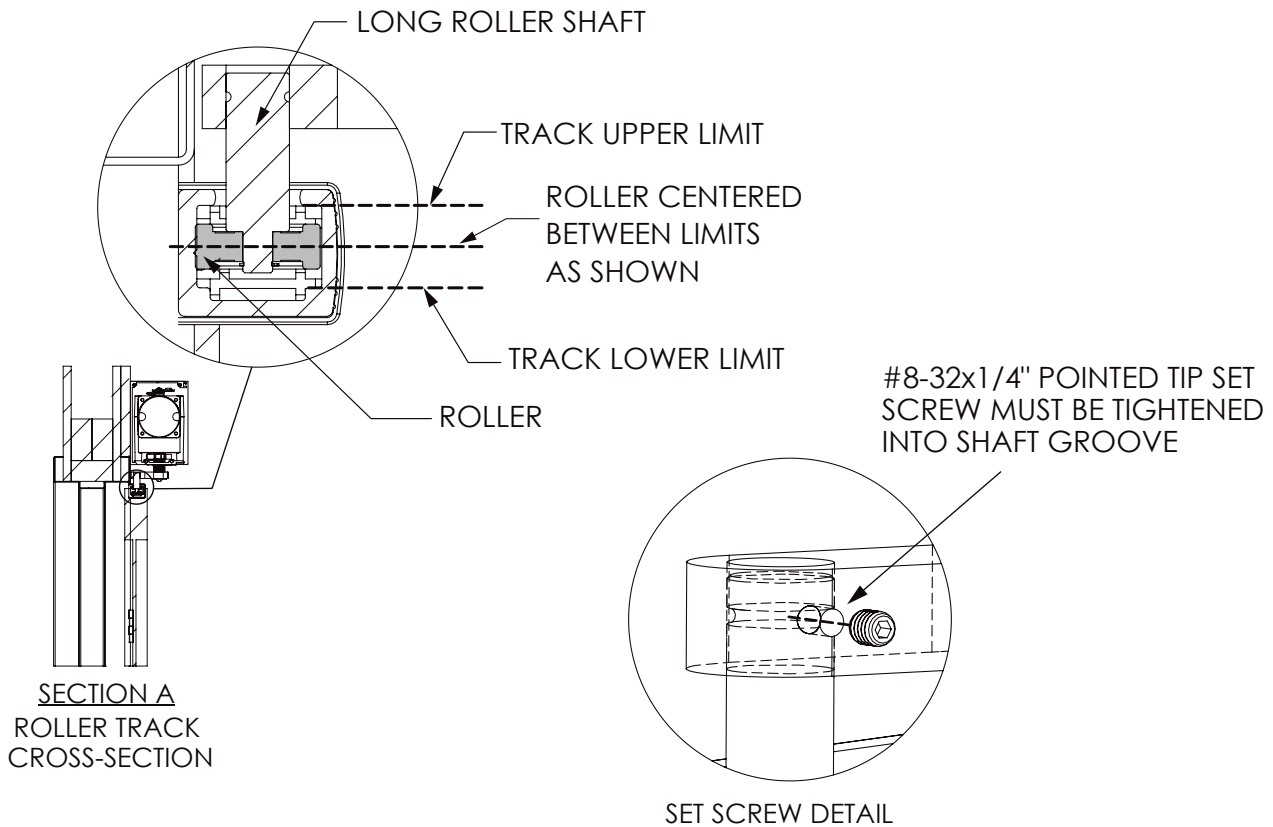
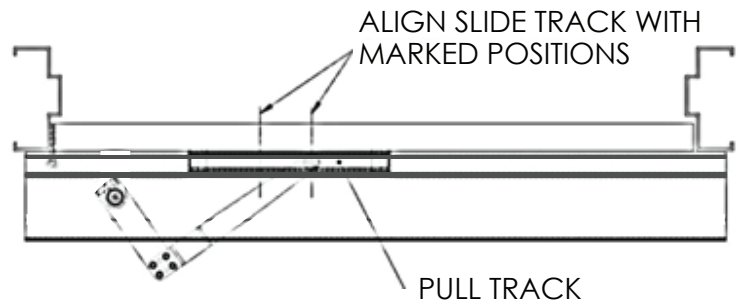

Make sure Pull track is installed level with the header. This is to ensure the roller stays inside the track during opening and closing, prolonging the life of the roller.

3.3 Universal Arm

Universal arm can be used as both push and pull arm, allowing flexibility to mount the HA8 on either side of the door opening.

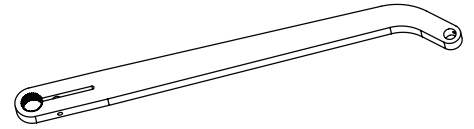

PUSH APPLICATION

DOOR 'PUSHED' OUT

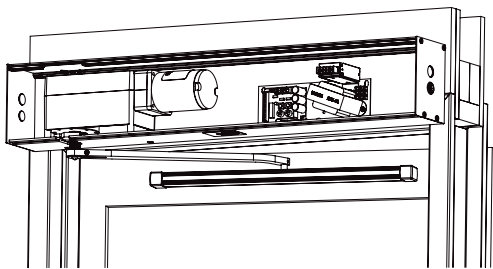
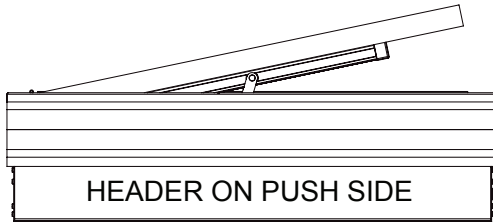

PULL APPLICATION

DOOR 'PULLED' OUT

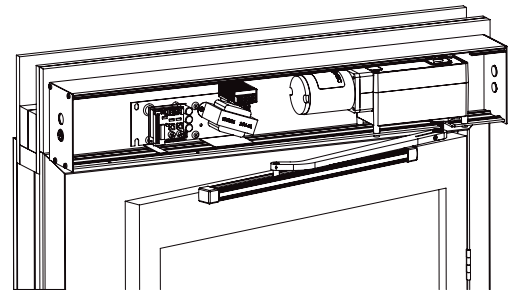
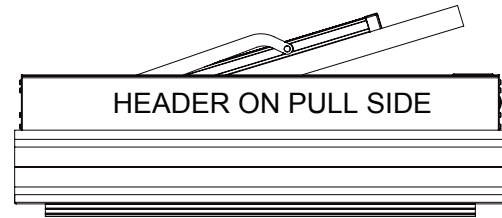

PUSH APPLICATION

IN **PUSH APPLICATION**,
BOTTOM OF HEADER,
MUST BE FLUSH WITH DOOR STOP
(ENSURE ARM CLEARS FROM
FRAME DURING SWING)

PULL APPLICATION

1.375in [34.92mm]
BOTTOM OF HEADER TO
BOTTOM OF FRAME

IN **PULL APPLICATION**,
SPINDLE MUST BE CLEARED
FROM TOP OF DOOR

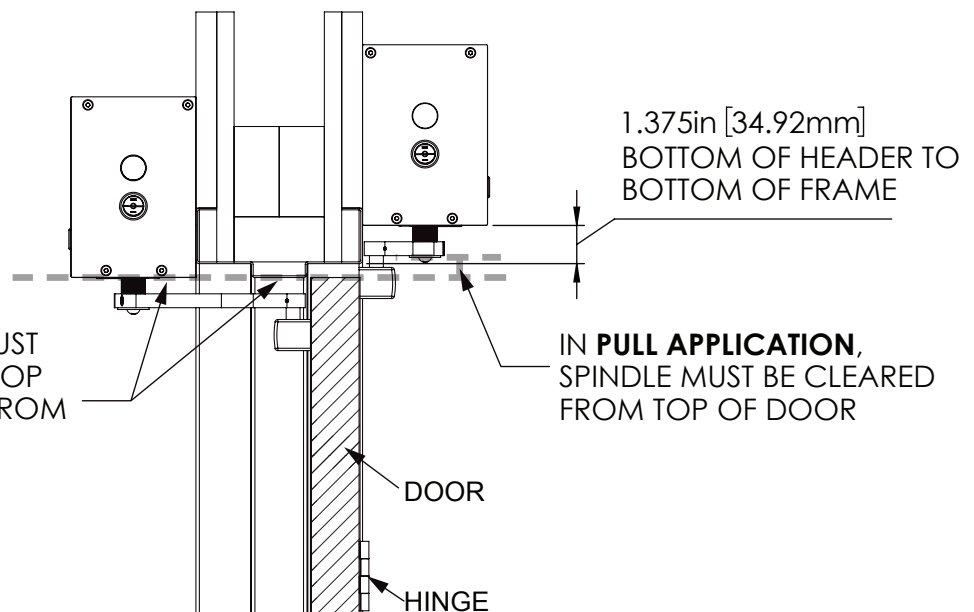

Universal Arm as Pull Application

STEP 1 - Universal Arm at Fully Close

- Close the door fully and fit the Universal arm to the drive shaft (spindle), so that the arm is parallel with the door.
- In this closed position, mark the spot where roller would touch door (directly below where the arm meets the door).

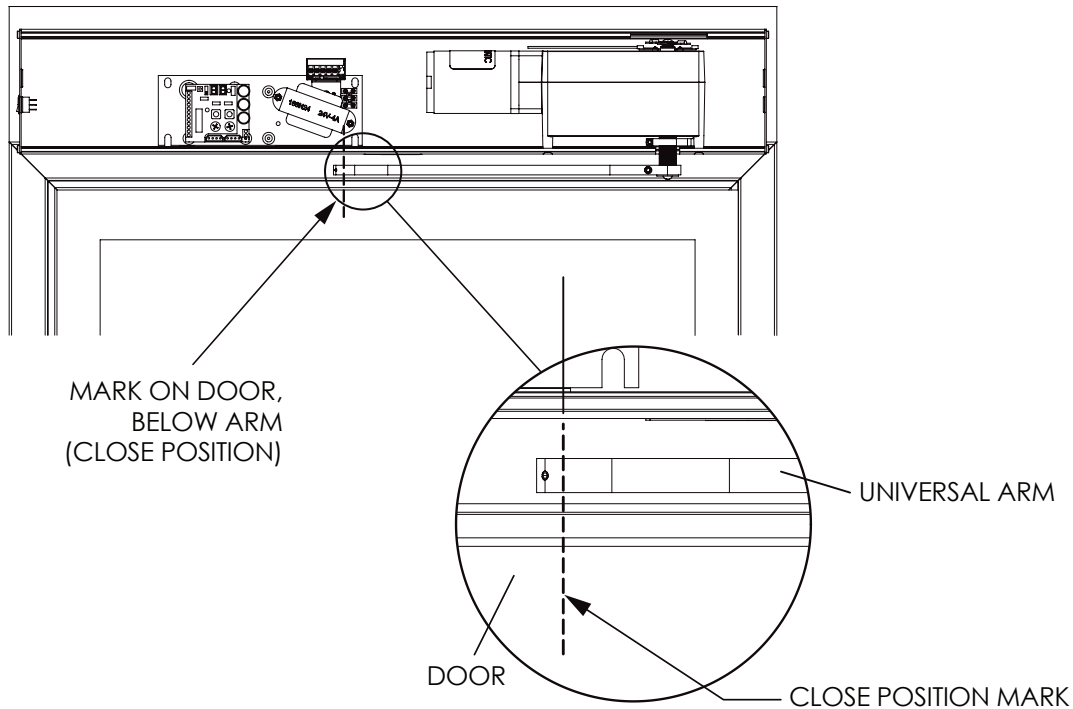

STEP 2 - Fully Open

- Open the door to full open.
- Set switch to Hold Open. The drive shaft (spindle) will turn fully until hitting the internal doorstop.

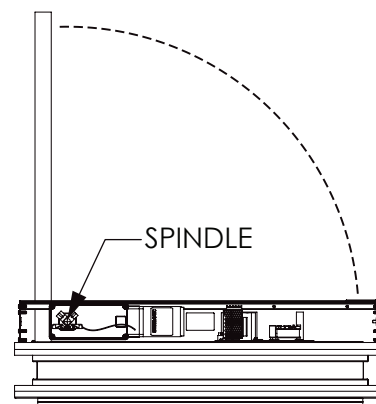

STEP 3 - Universal Arm at Fully Open

- Fit the Universal arm to the drive shaft (spindle) at full open position, but do not tighten the #1/4-20 x 7/8" socket cap screw all the way. This is to allow the arm some freedom/flexibility. The Universal Arm must be positioned such that it is just in front of the door as shown.
- Mark the spot where the roller would touch the door (directly below where the arm meets the door). This is the open position.

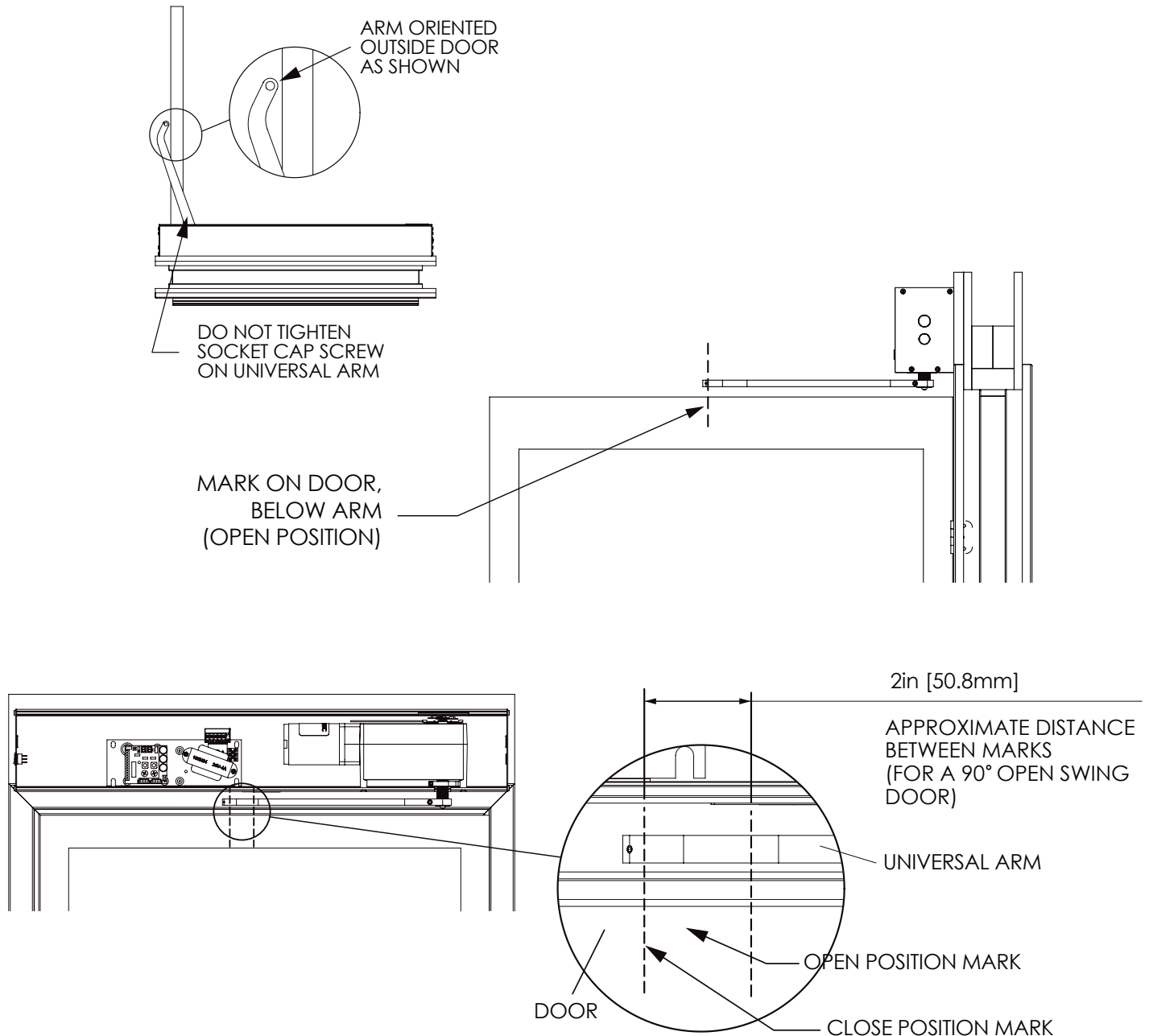

STEP 4 - Fitting Pull Track

- Open and close position marks illustrate the travel of the roller during the door swing, and thus must be within the universal track after mounting. For a pull (with door opening 90 degrees), these two marks should not be more than a few inches apart. For larger than 90 degrees opening, this distance will increase.
- Fit the Universal arm to the drive shaft (spindle) at full open position.
- Remove the two ends caps and fit the extended pull track to cover the 1st and 2nd mark.
- Fix to the door, using the #14-10x1" Phillips/Square Pan Self-Tapping Screws provided in the screw pack (or fastener of your choice). You may center the roller track in the door for visual aesthetics if the door width allows, but ensure the track covers the open and close marks for correct operation.
- Re-attach the two end caps to hide the screws.

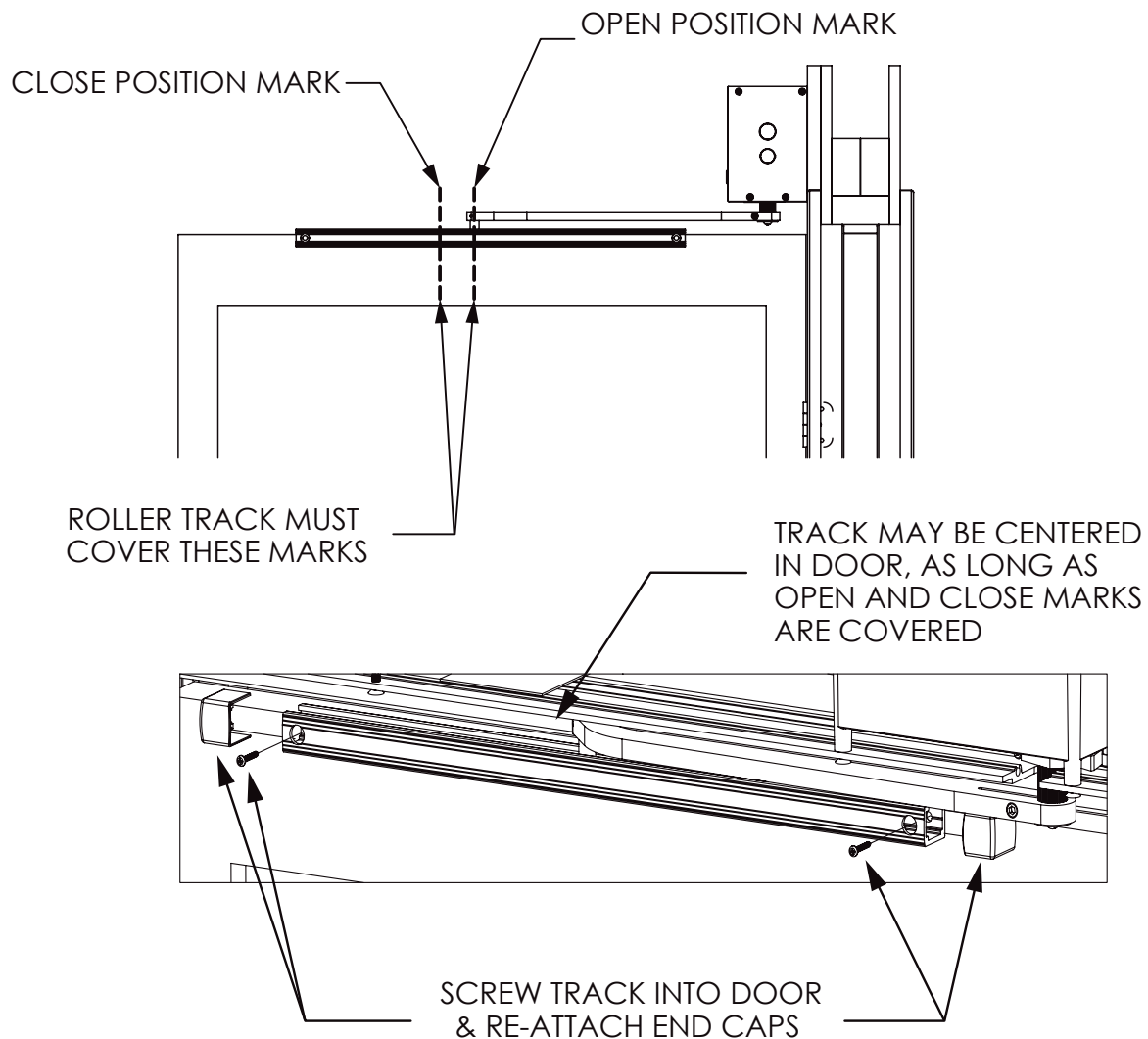

STEP 5 - Attaching Universal Arm

- Attach the roller shaft to the arm as shown, making sure the set screw is tightened into the groove on the roller shaft. This will ensure that the arm and shaft do not dislocate during operation. For optimal performance, the roller should be in-between the track limits as indicated.
- Tighten the #1/4-20x7/8" socket cap screw for the male and female splines to grip correctly.
- Turn switch to Automatic or ON.
- Test and adjust if necessary.

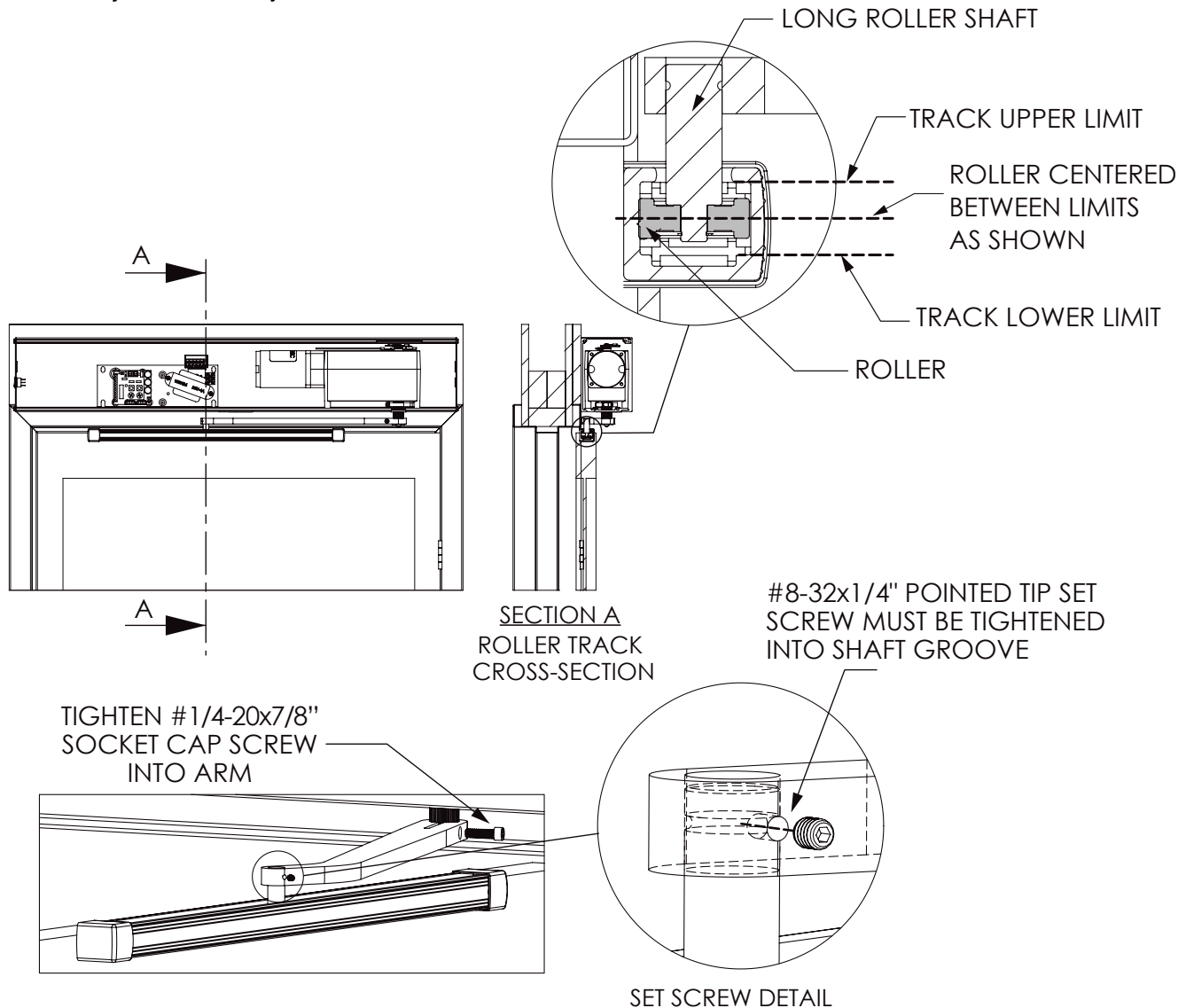

Make sure Pull track is installed level with the header. This is to ensure the roller stays inside the track during opening and closing, prolonging the life of the roller.

Universal Arm as Push Application

For installing Universal arm as Push application, what is critical is that the bottom of the header be mounted in line with the bottom of the top jamb door stop. This is to ensure that the arm has enough clearance when swinging through the upper jambs.

STEP 1 - Universal Arm at Fully Close

- Close the door fully. Then do the same with the arm parallel to the closed door.
- In this closed position, mark the spot where roller would touch door (directly below where the arm meets the door).

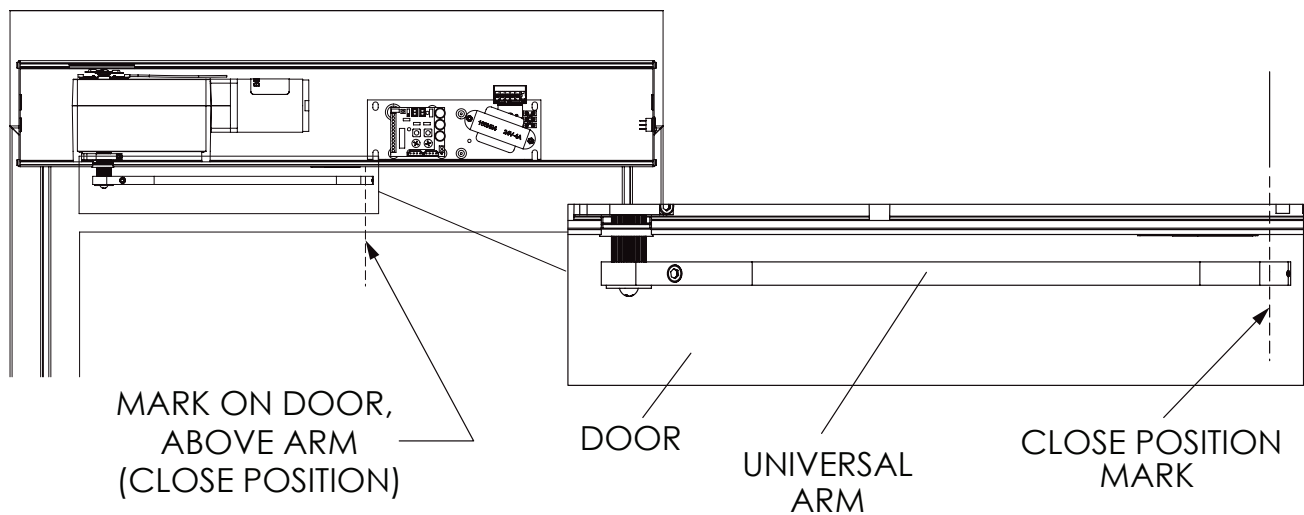

STEP 2 - Fully Open

- Open the door to full open and set switch to Hold Open.
- The drive shaft (Spindle) will turn fully until hitting the internal doorstop.

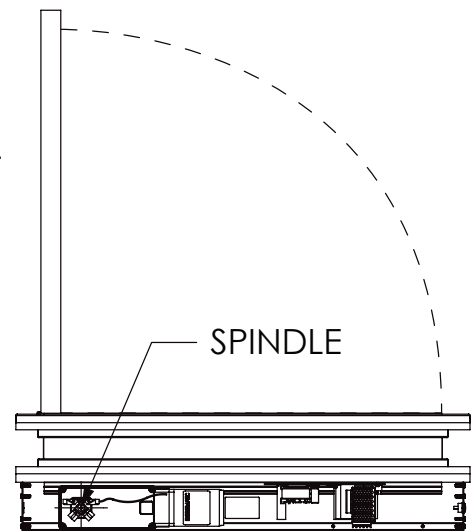

STEP 3 - Universal Arm at Fully Open

- Fit the Universal arm to the drive shaft (Spindle) at the full open position, but do not tighten the #1/4-20x7/8" Socket Cap Screw all the way. This is to allow the arm some freedom/flexibility.
- Mark the spot where the roller would touch the door (directly below where the arm meets the door). This is the open position.

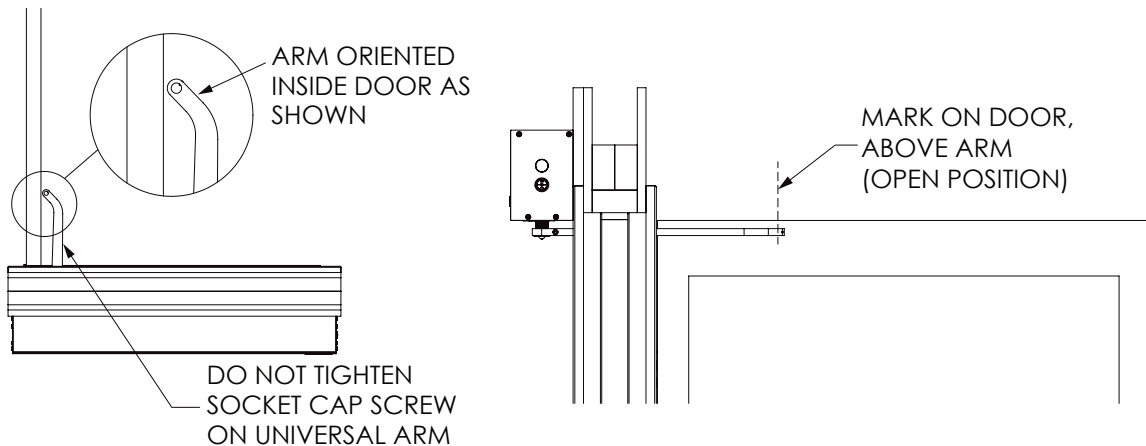

STEP 4 - Fitting Pull Track

- These two marks (open and close) illustrate the travel of the roller during the door swing, and thus must be within the universal track after mounting. For a push (with door opening 90 degrees), these two marks will be around 10-12 inches apart.
- Repeat STEP 1 and 2
- Remove two ends caps and fit the extended pull track to cover the 1st and 2nd mark.
- Fix to the door, using the #14-10x1" Phillips/Square Pan Self-Tapping Screws provided in the screw pack (or the fastener of your choice). You may center the roller in the door for visual aesthetics if the door width allows, but ensure the track covers the open and close marks for correct operation.
- Re-attach the two end caps to hide the screws.

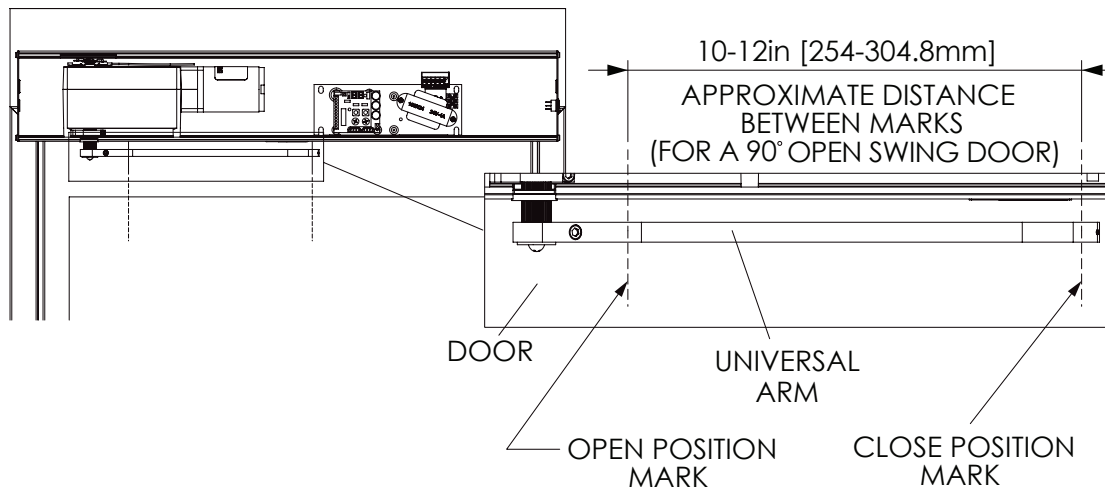

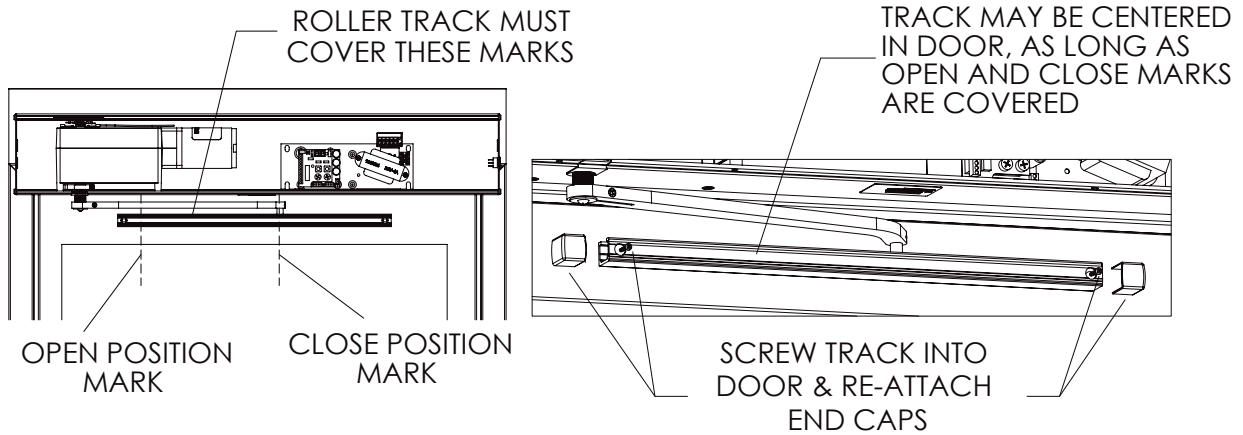

STEP 5 - Attaching Universal Arm

- Attach the roller shaft to the arm as shown, making sure the set screw is tightened into the groove on the roller shaft. This will ensure that the arm and shaft do not dislocate during operation.
- Tighten the #1/4"-20x7/8" socket cap screw for the male and female splines to grip correctly.
- Turn switch to Automatic or ON.
- Test and adjust if necessary.

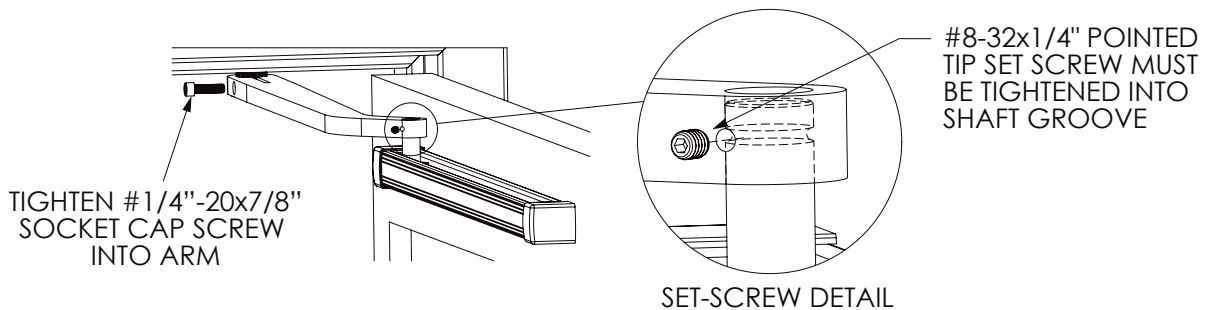
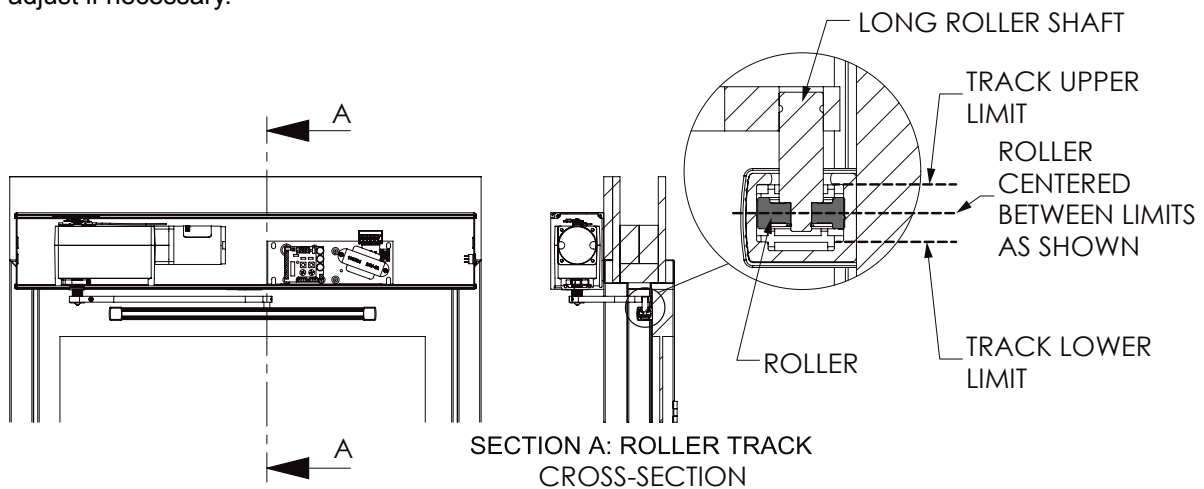

Make sure Pull track is installed level with the header. This is to ensure the roller stays inside the track during opening and closing, prolonging the life of the roller.

3.4 Center Spindle (Concealed)

Center Spindle can be used in concealed application to achieve a clean look.

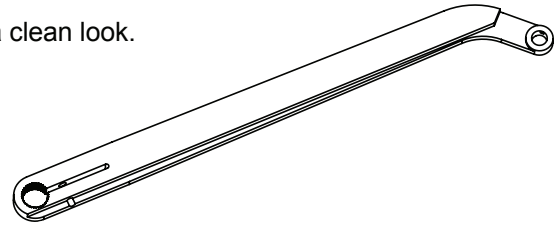

The track must be installed in the top web of the door.

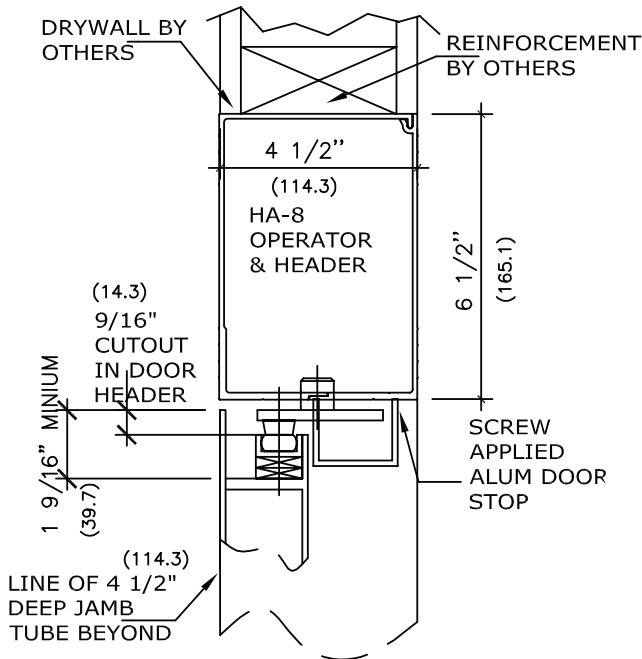

VERTICAL SECTION

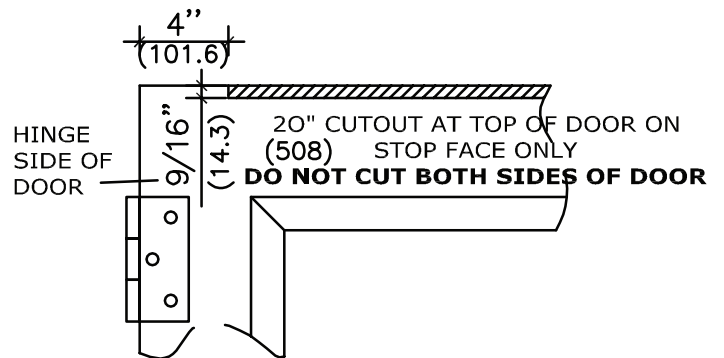

ELEVATION OF DOOR

3.5 Center Hung

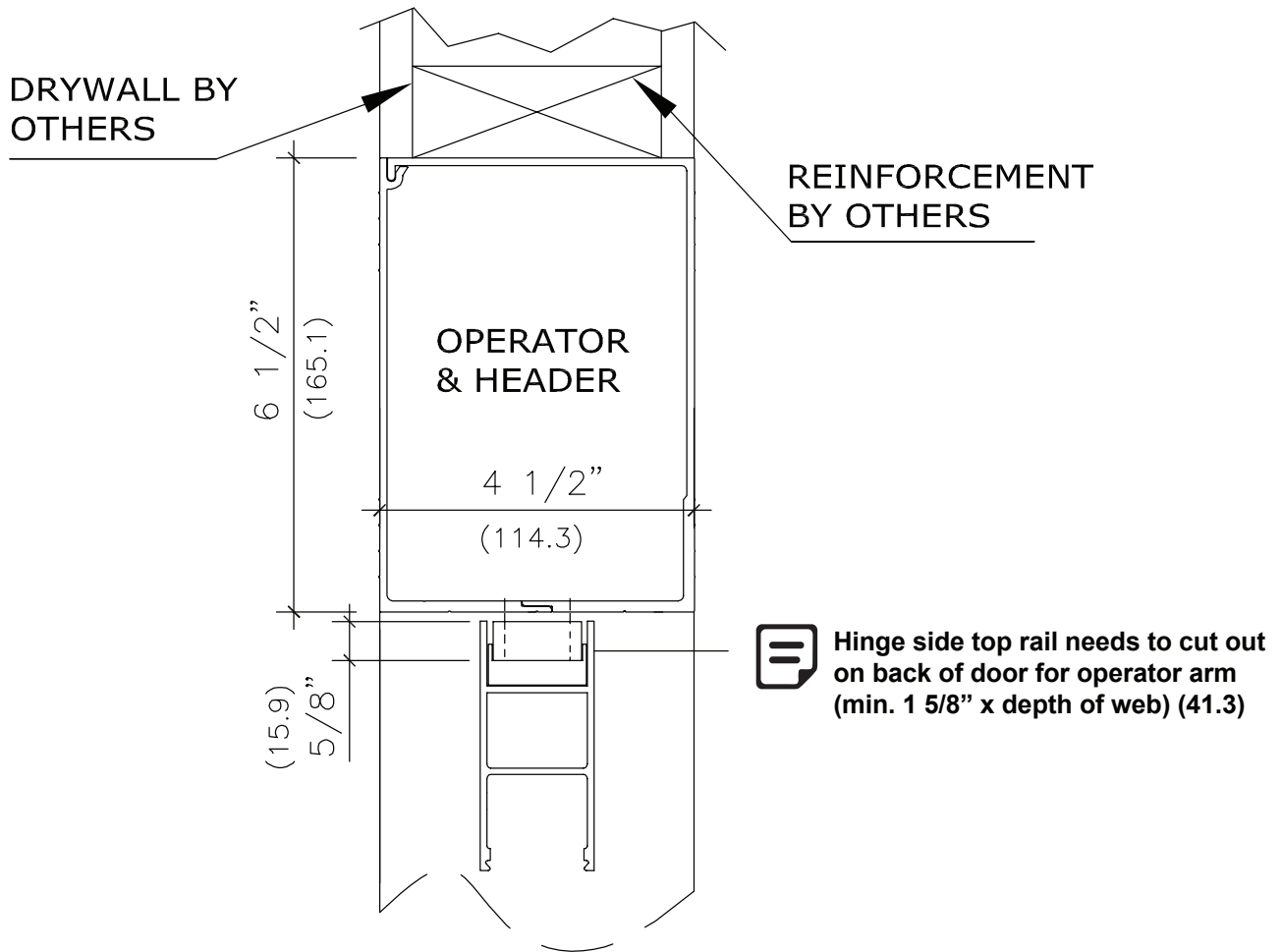
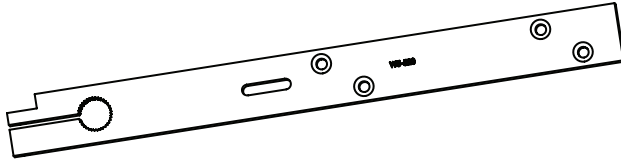

VERTICAL SECTION

4.1 Operator Factory Default Setting

The factory default position of the Limit Switches (Magnets) are shown below.

LEFT HAND OPERATOR

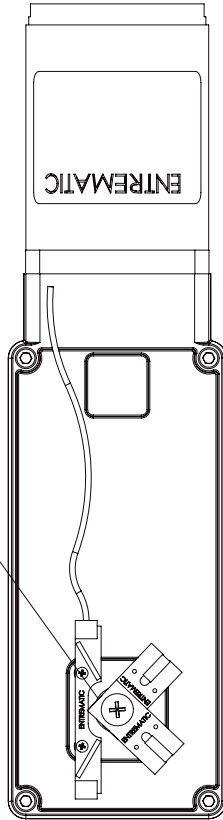

MAGNETS AT 90°
POINTING TO
THE LEFT

RIGHT HAND OPERATOR

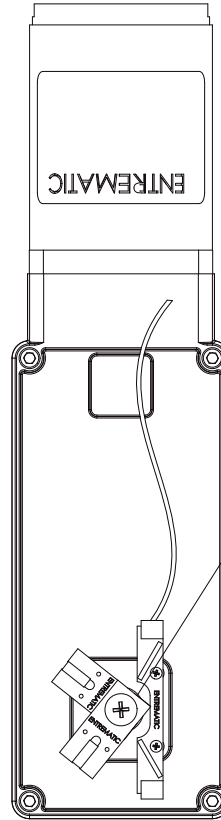

MAGNETS AT 90°
POINTING TO
THE RIGHT

LATCH CHECK REED
(NO GREY WIRE)

BACK CHECK REED
(WITH GREY WIRE)

**BACK CHECK WILL
ALWAYS BE READ ON
THE TERMINAL WITH
GREY REED SWITCH WIRE**

UPPER MAGNET
(LIMIT SWITCH)
USE FOR LATCH
CHECK

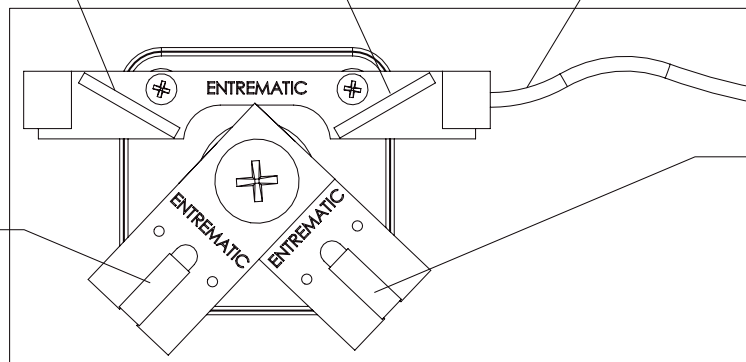

LOWER MAGNET
(LIMIT SWITCH)
USE FOR BACK
CHECK

4.2 How it Works

Below illustrations explain how the Limit Switches (Magnet) are related to door position.

STEP 1 - Door Starts in Close position

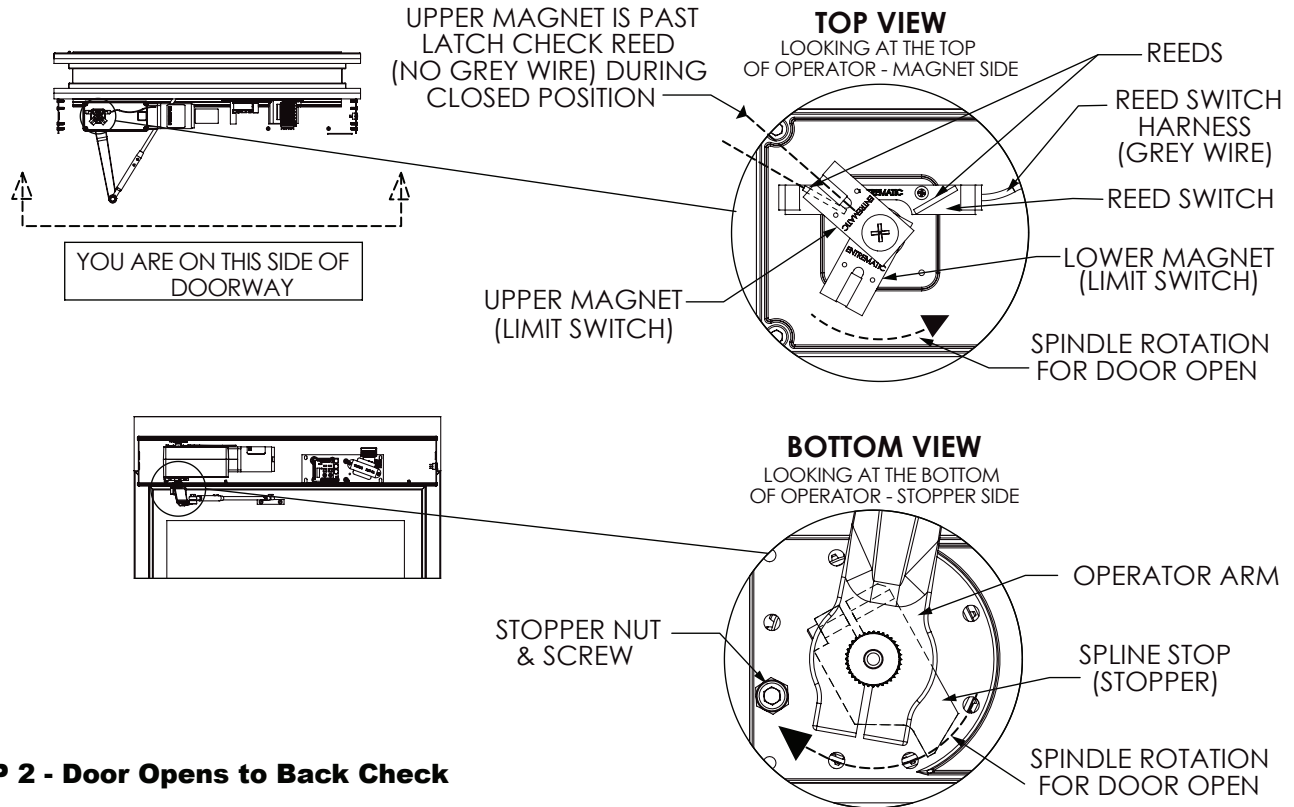

STEP 2 - Door Opens to Back Check

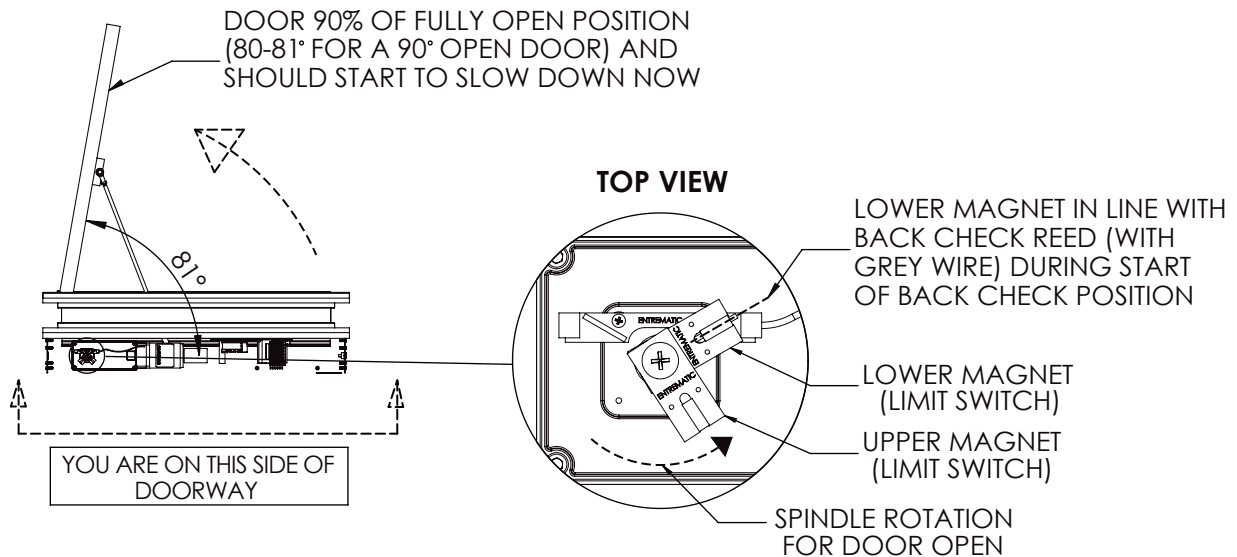

STEP 3 - Door Stops at Fully Open via Stopper



If your door can be manually opened until it hits a wall or other obstruction without stopping, then the operator has been set up incorrectly. Please refer back to section 3.0: Arm Installation, and ensure the arm is only put on after the switch has been set to Hold Open and the stopper has hit the nut.

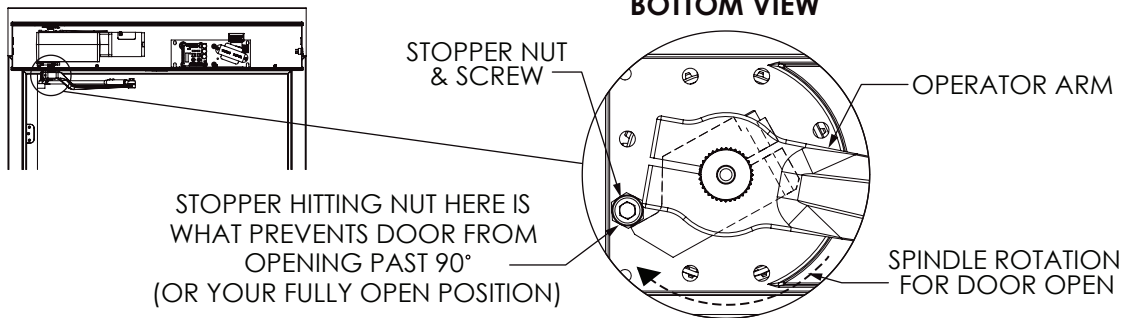
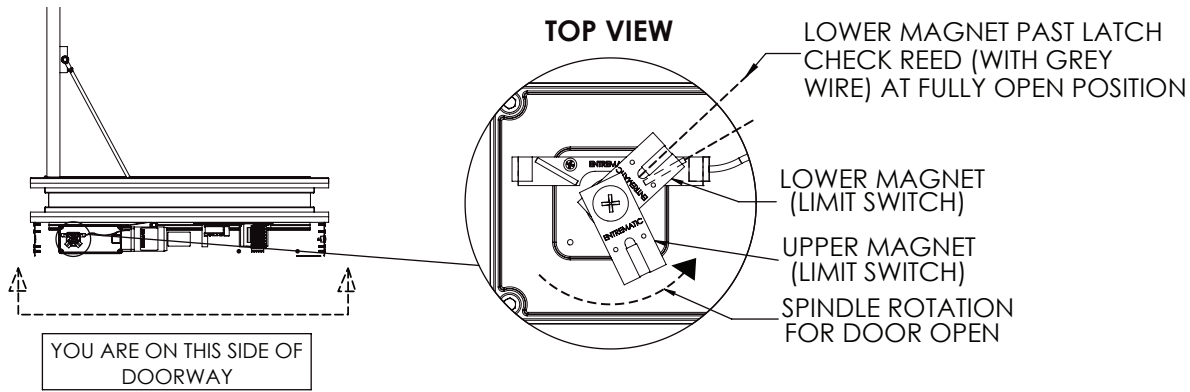

STEP 4 - After Time-out, Door close to Latch check

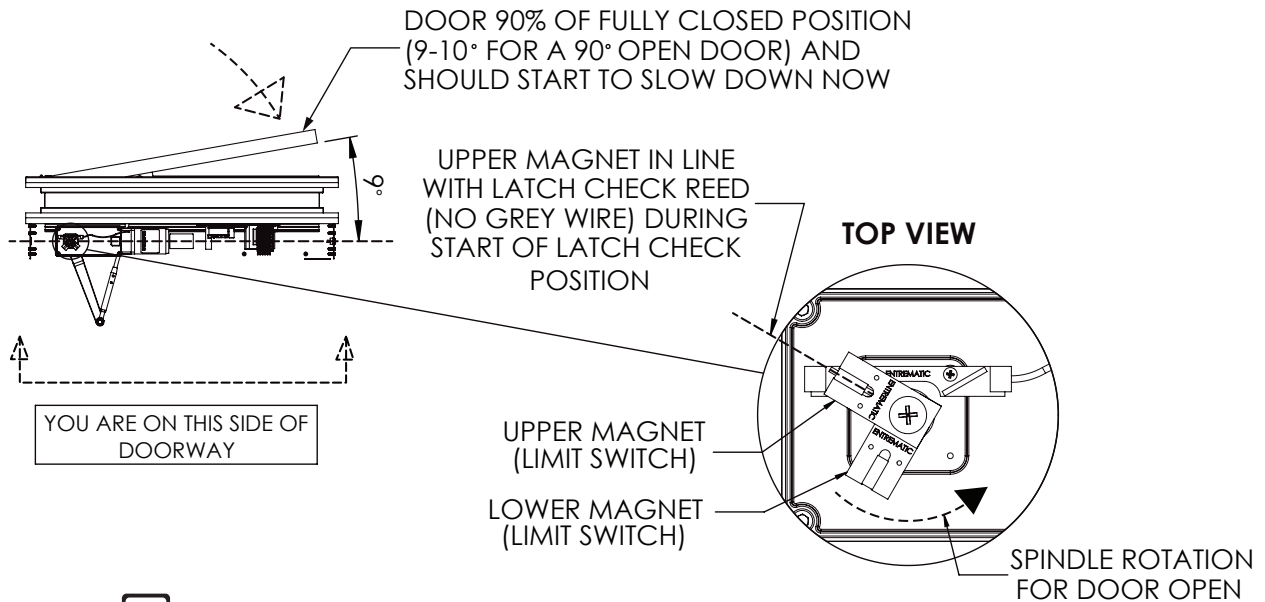

Door and Magnets will then return to positions in STEP 1

4.3 Back Check and Latch Adjustment

Back Check Adjustment

Set the door to full open position, lower magnet should cross over the back check switch (where grey wire conductor plugs into green circuit board) engaging back check speed 10 degrees prior to the door reaching fully open.

The control board slows the door to a gentle stop at the fully open position. Doors shall be adjusted so Back check will not occur before 60 degrees of opening (maximum, preferred at 10 degrees before full open).

Latch Adjustment

Set the door to close position, upper magnet should be over the latch reed switch. This magnet signals the controller to slow the closing door speed before stopping at the latch or doorstop.

Back Check & Latch - Left Push Application

LEFT HAND PUSH

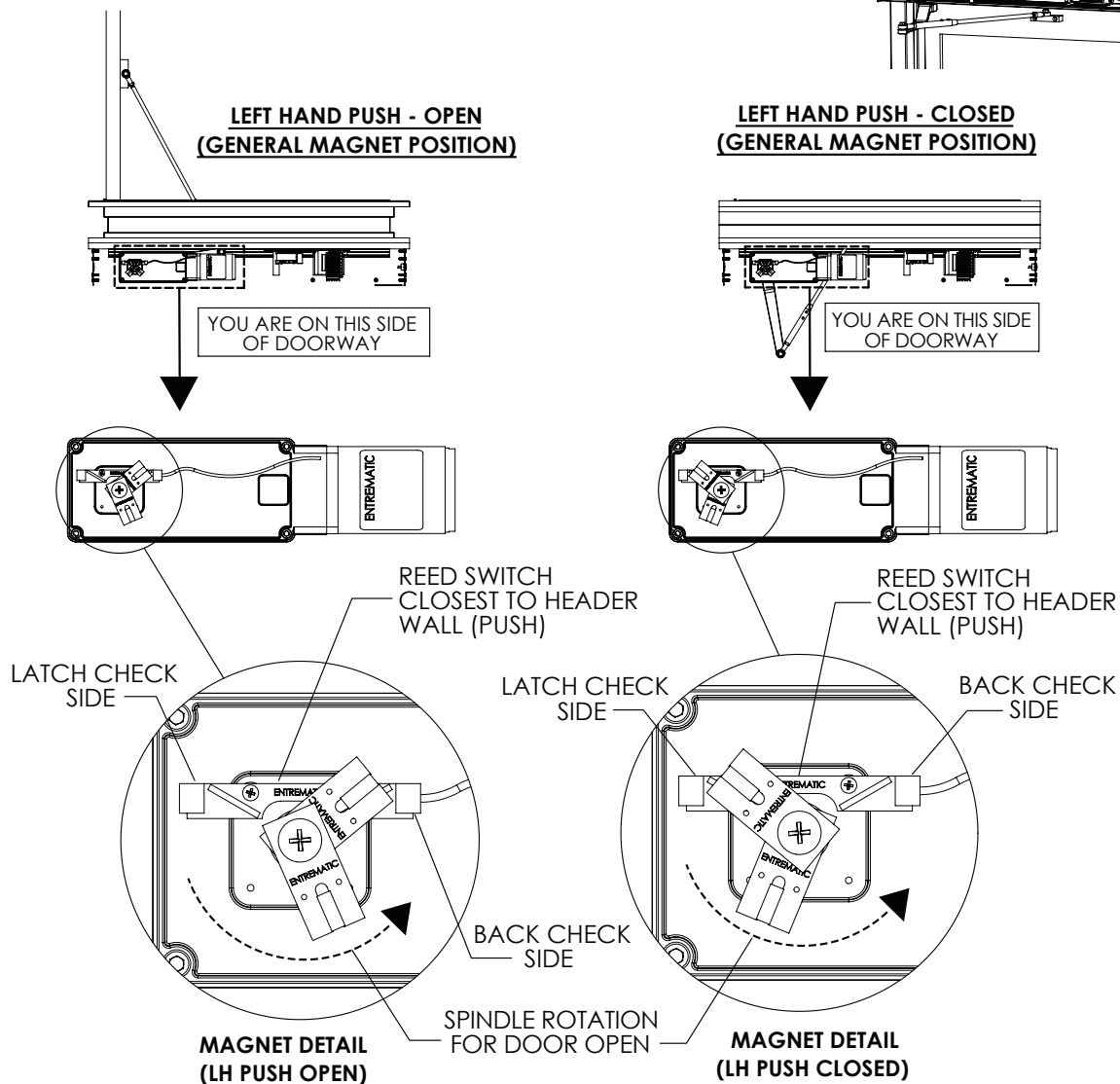
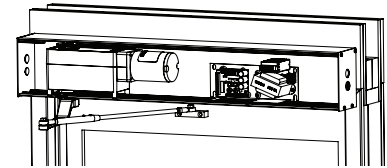

Back Check & Latch - Right Push Application

RIGHT HAND PUSH

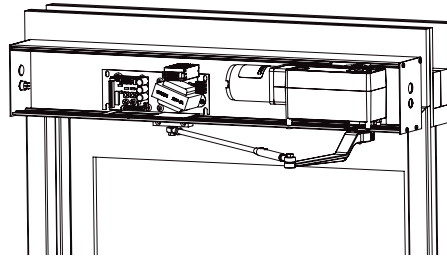

RIGHT HAND PUSH - OPEN (GENERAL MAGNET POSITION)

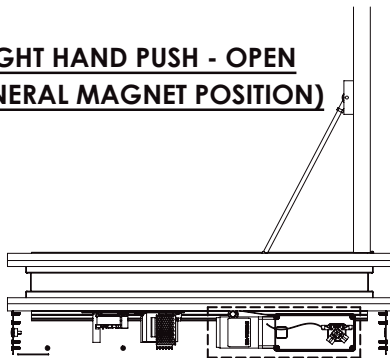

YOU ARE ON THIS SIDE OF DOORWAY

RIGHT HAND PUSH - CLOSED (GENERAL MAGNET POSITION)

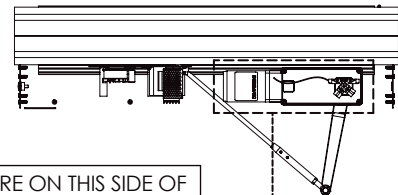

YOU ARE ON THIS SIDE OF DOORWAY

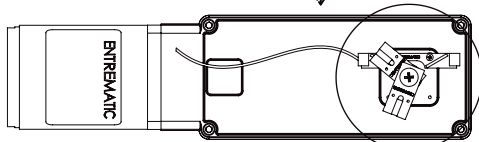

REED SWITCH CLOSEST TO HEADER WALL (PUSH)

REED SWITCH CLOSEST TO HEADER WALL (PUSH)

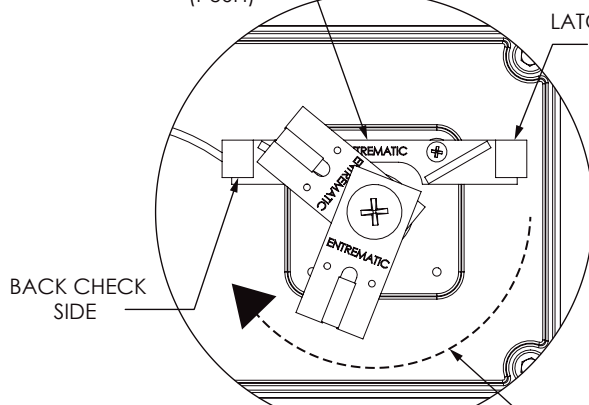
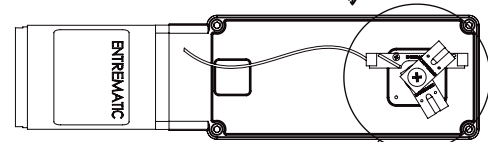

MAGNET DETAIL (RH PUSH OPEN)

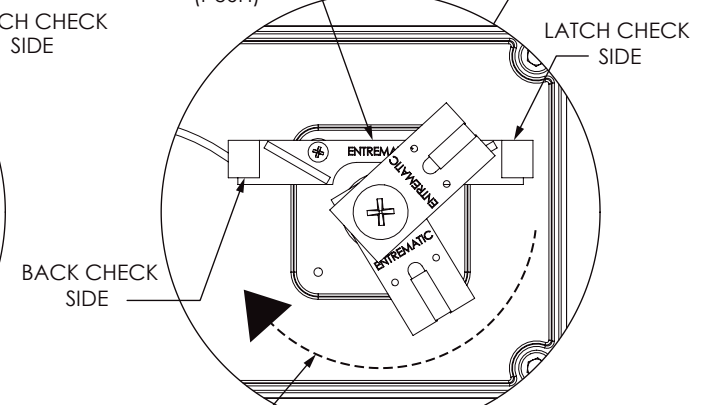

MAGNET DETAIL (RH PUSH CLOSED)

SPINDLE ROTATION FOR DOOR OPEN

Back Check & Latch - Left Pull Application

LEFT HAND PULL

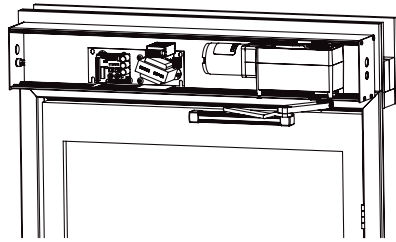

LEFT HAND PULL - CLOSED (GENERAL MAGNET POSITION)

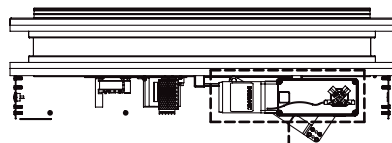

YOU ARE ON THIS SIDE OF DOORWAY

LEFT HAND PULL - OPEN (GENERAL MAGNET POSITION)

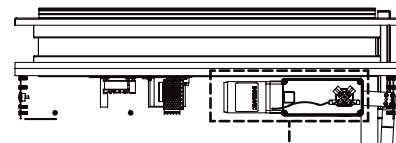

YOU ARE ON THIS SIDE OF DOORWAY

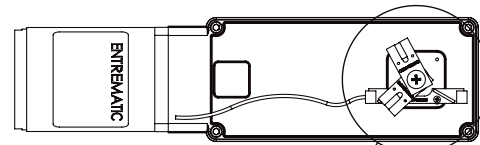
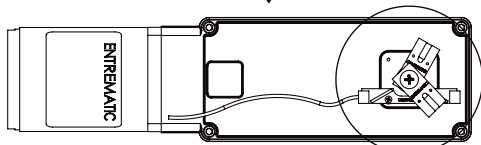

SPINDLE ROTATION FOR DOOR OPEN

BACK CHECK SIDE

BACK CHECK SIDE

REED SWITCH AWAY FROM WALL (PULL)

REED SWITCH AWAY FROM WALL (PULL)

LATCH CHECK SIDE

MAGNET POSITIONS
(LH PULL CLOSE)

MAGNET POSITIONS
(LH PULL OPEN)

Back Check & Latch - Right Pull Application

RIGHT HAND PULL

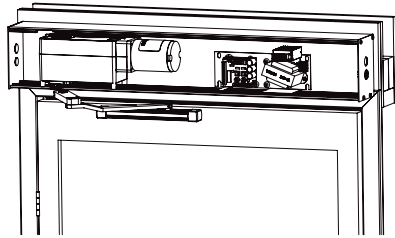

RIGHT HAND PULL - CLOSED (GENERAL MAGNET POSITION)

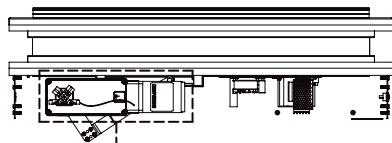

YOU ARE ON THIS SIDE OF
DOORWAY

RIGHT HAND PULL - OPEN (GENERAL MAGNET POSITION)

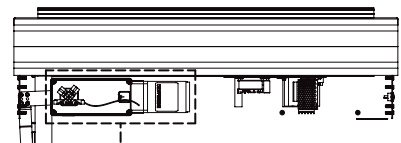

YOU ARE ON THIS SIDE OF
DOORWAY

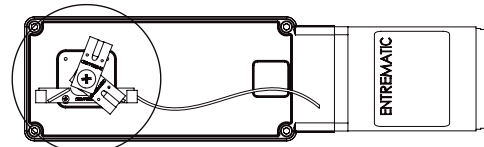
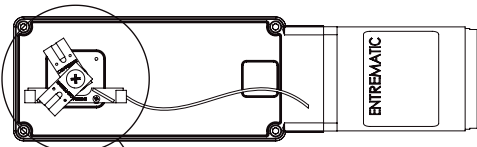

SPINDLE
ROTATION FOR
DOOR OPEN

LATCH
CHECK
SIDE

LATCH
CHECK
SIDE

REED SWITCH
AWAY FROM
HEADER WALL
(PULL)

BACK
CHECK
SIDE

BACK
CHECK
SIDE

MAGNET POSITIONS
(RH PULL CLOSE)

REED SWITCH
AWAY FROM
HEADER WALL
(PULL)

MAGNET POSITIONS
(RH PULL OPEN)

4.4 Spring Tension Adjustment

This is useful for windy locations, and other areas where the door may need more force during the closing phase.

To begin,

- Remove the operator from the header.
- Remove the fender washer and machine screw at the end of the spindle.
- Detach the operator arm and remove the other two machine screws holding the operator to the header.
- You may now remove the operator, placing on secure flat surface on its side.

Method 1: Adjusting Spline Stop Position

STEP 1 - Loosen Stopper

Loosen the socket cap screw that keeps the spline stop anchored in place.

 RH operator orientation adjustment are shown. For LH operator, please reverse the images.

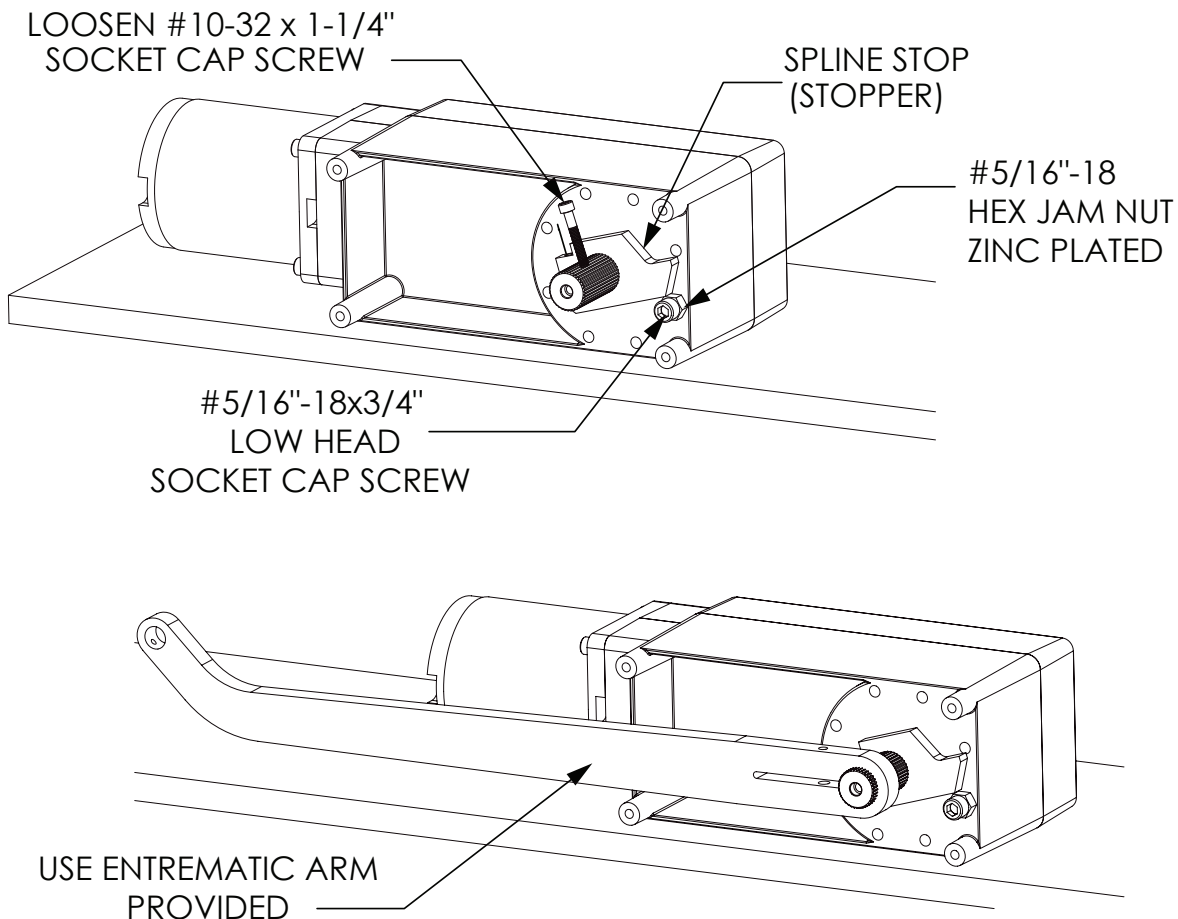

STEP 2 - Removing Existing Spring Tension

Place the spline operator arm into the spindle. This arm should have the same spline characteristics as the spindle shaft, in order to ensure accurate grip.

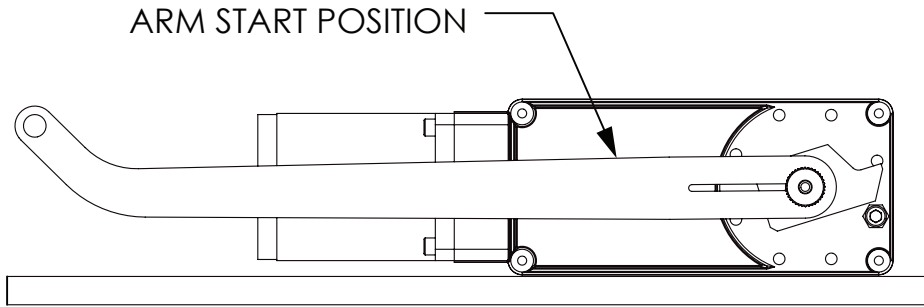

Wind the arm such that there is some clearance between the spline stop and nut.

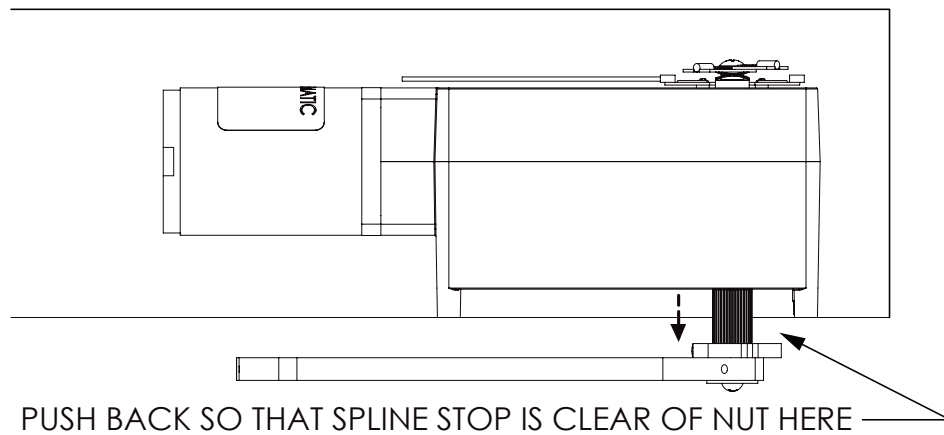
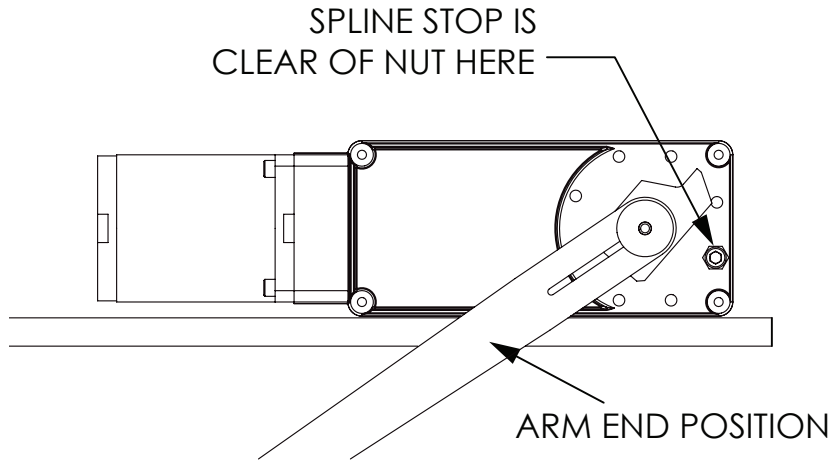

Slowly allow the spring to unwind, to remove all factory-default spring tension. Your operator should look as shown below.

Now that there is no tension in the spring, you may remove the spline stop from the spindle shaft.

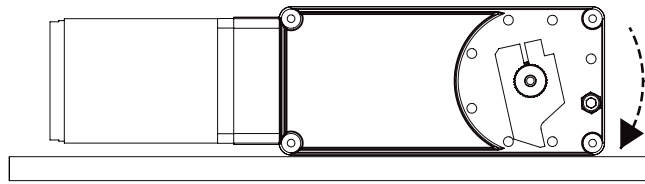

RH OPERATOR

ALLOW SPLINE STOP TO ROTATE CLOCKWISE TO REMOVE EXISTING SPRING TENSION. COUNTER CLOCKWISE FOR **LH OPERATOR**.

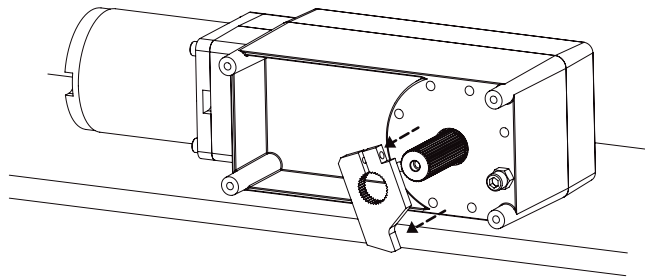

STEP 3 - Adjust Stopper Position

To add more closing force to the door, you must re-insert the spline stop onto the shaft. The recommended maximum position is about a third of a turn (~135 degrees) as shown below. Anything beyond this point puts excessive stress on the spring, and also exceed AAADM recommendation of closing force.

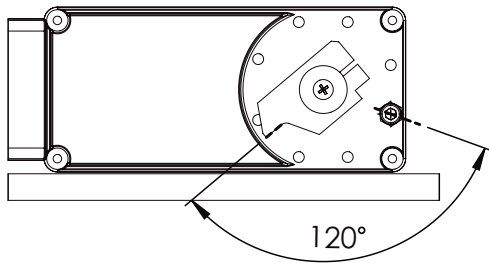

**"W5-105" REGULAR SPRING
FACTORY DEFAULT POSITION**

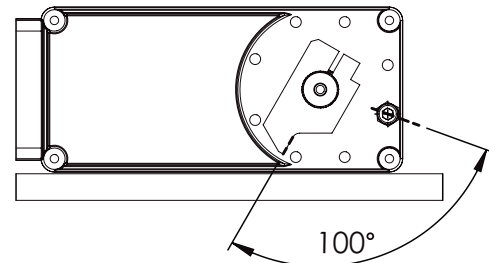

**"W5-106" XP SPRING
FACTORY DEFAULT POSITION**

**ADDING SPRING TENSION,
MAX POSITION**

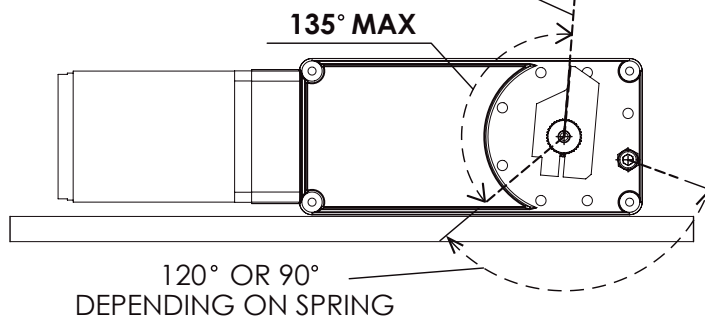

STEP 4 - Eliminate Spring Slack

Once the spline stop is in the appropriate position, eliminate the existing spring slack by hand manually turning the spline stop towards the nut.

For Right Hand operator, turn the spline stop counterclockwise towards the nut.

For Left Hand operator, turn the spline stop clockwise towards the nut.

This step is to ensure the spring is tight from the get go, and does not lose any tension (closing force) after wind.

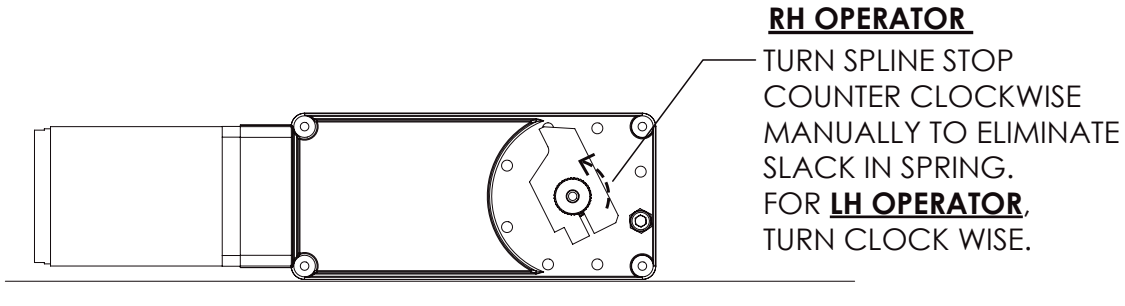

STEP 5 - Add Spring Tension

Using the operator arm, wind the stop until it is above the nut.



Remember to secure operator as injury may occur while adjusting spring tension, if operator not held in place.

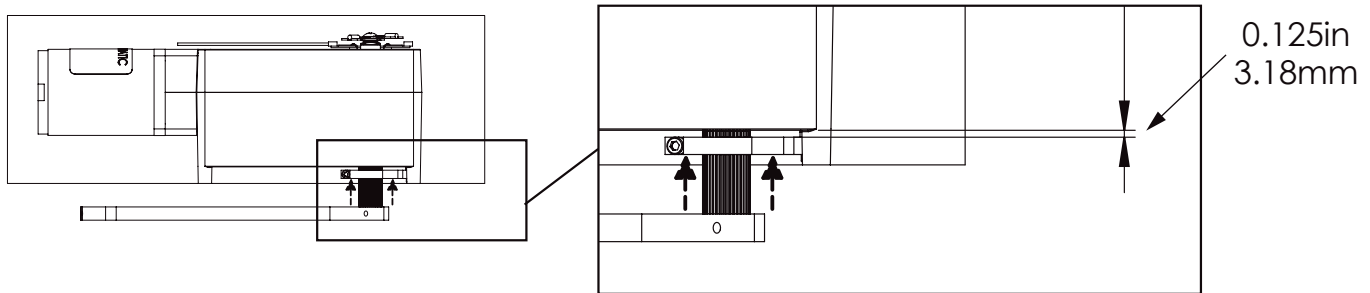
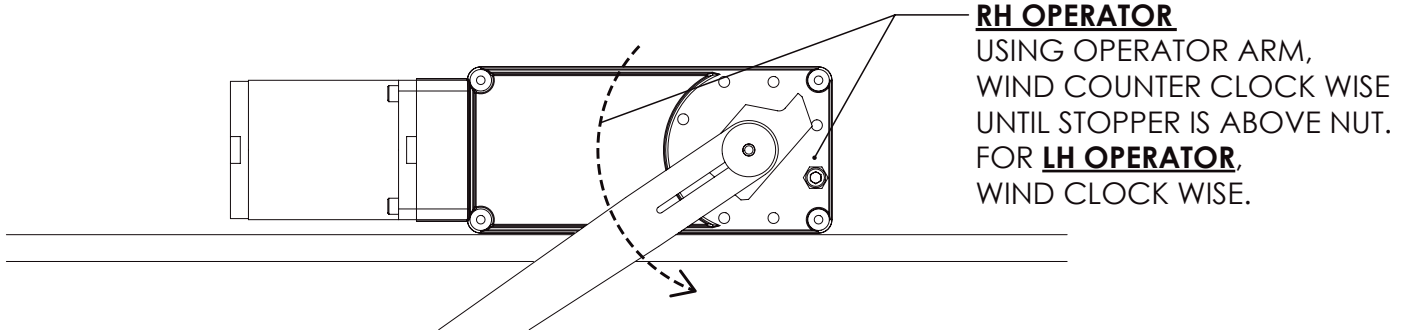

After adjustment, reinstall operator and other components as shown in section 2.0 and onward.

Method 2: Adjusting Physical Stop Location

DEFAULT STOP LOCATIONS

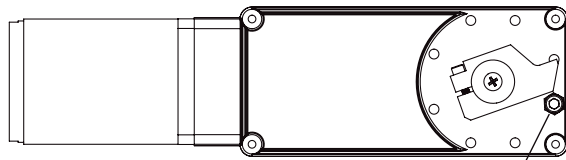

RH OPERATOR STOP
DEFAULT HOLE LOCATION

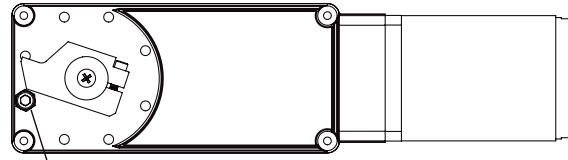

LH OPERATOR STOP
DEFAULT HOLE LOCATION



To increase spring tension, rotate arm in the direction of spindle rotation.
To decrease spring tension, allow arm to unwind opposite to spindle rotation.

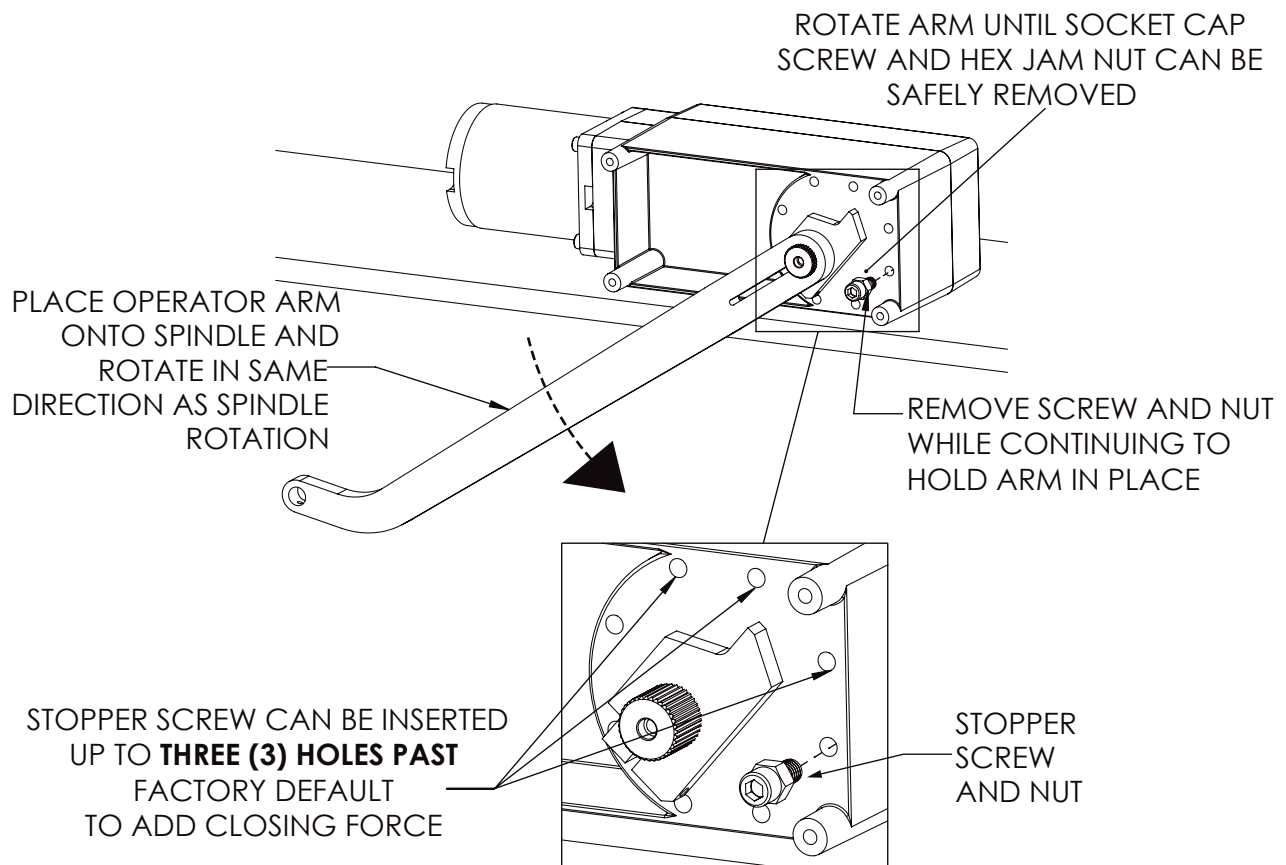

5.1 Basic Operation

Basic Operation

- When the door receives activation, the door opens and brakes before the fully open position and opens slowly to the full doorstop position, following the programmed data.
- Once pre-set open period is complete, the door will close at the pre-set closing speed, braking to low speed a little before the fully closed position and closes slowly.
- When an activation signal activates while the door is closing, the door will stop and reverse to open.

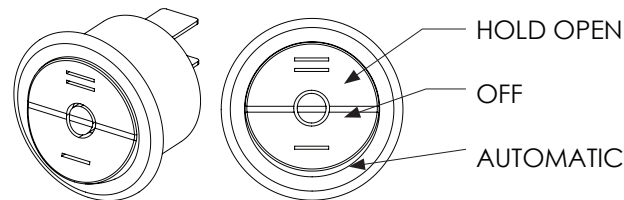

5.2 Operation Switch



The Operation Switch must be set to Automatic (I) position to allow changes to be made in programming.

- Operation (3 position) Switch is located on the end plate.
- With the door in the closed position. Check that the door is unlocked and the main power switch is on.

Automatic Mode (I)

- This mode sets to activate the operator
- Activate the push button or knowing act device. The door opens to about 80 degree position at full speed, and then will slow for the final 10 degree of opening until full open is complete. (There is no need for a learning cycle as the open position is already pre-set during installation).
- After the pre-set open time is complete, the door will begin to close at the set closing speed, until the final 10 degree of closing, when the door will slow for the final 10 degree of closing until the full latch position.

Hold Open Mode (II)

- This mode sets to hold the door open automatically for an extended length of time.
- No activation or safety sensor signals will be active in this mode as the door is stationary in the open position. The door will remain held open continually by a pulsed signal to the motor without overheating.
- To close the door, move the switch to either Automatic (I) or OFF (O) position, and the door will close smoothly and gently to the full closed position.

OFF (Manual) Mode (O)

- This mode sets to deactivate all opening signals, and the door is opening and closing manually.
- No activation signals or safety sensor signals (if equipped) will be active in this mode as the door is stationary in the closed position.
- Power will remain ON and supplied to the unit, however all signals will be ignored. The door can be opened easily with minimum force.

6.1 Digital Board Specification

INPUTS

	LINE VOLTAGE		TRANSFORMER (Hammond)
AC VOLTAGE	120VAC 60Hz	Fully Automatic	#166N24 – 24VAC – 4AMP
		Handicap	#166M16 – 16VAC – 3AMP
	240VAC 50Hz	Fully Automatic	#266N24 – 24VAC – 4AMP
		Handicap	#266M16 - 16VAC – 3AMP

- ACTIVATION 1 (ACT'N1)**
- First input to open the door. Instant activation (i.e. push buttons)
 - ON = Closed contact to ground/common.
 - See Function AA", Setting A1" for description of alternate operation
- ACTIVATION 2 (ACT'N2)**
- Second input to open the door. Delayed activation.
 - ON = Closed contact to ground/common.
 - See Function AA", Setting A1" for description of alternate operation.
- SAFETY 1**
- For Safety1 ON door will not open if presently fully closed and door will not close if presently fully opened (i.e. overhead presence sensors - Bodyguard)
 - ON = Closed contact to ground/common.
- SAFETY 2**
- For Safety2 ON and Activation1 input ON door will drive at hold speed. If Activation1 input goes off door closes. If Safety2 goes off door will open. (i.e. Door mounted sensor on swing side - Superscan)
 - ON = Closed contact to ground/common.

OUTPUTS

- MOTOR**
- 2 motor connectors to drive door in either clockwise or counter clockwise direction.
- DATA- and DATA+**
- Interface with BEA Bodyguard sensor. (replaces LO-21K lockout relay)

OTHER FEATURES

- CLOSING SPEED**
- Adjustable by potentiometer
- BACK CHECK and LATCHING**
- 1 switch for each
- LOCKOUT**
- Lockout of door while closing is selectable via Function AA", Setting A2".
- PUSH AND GO**
- When Push and Go is selected a manual push of the door will trigger the door to open. Selectable via Function AA", Setting A3". Default is OFF
- OVERLOAD**
- Selectable Overload setting. Adjustable by potentiometer.
- ON/OFF/ HOLD OPEN**
- Terminal block position to accommodate a 3 way switch for ON, OFF and Hold Open positions.

(Updated Nov 2017)

There are two 7 SEGMENT LED DISPLAYS used for programming:

Function LED = Programmed Function

Setting LED = Value of the Function indicate on First digit



The Operation switch must be set to "ON" or "Automatic" positions to allow changes to be made in programming.

There are 3 switches that relate to programming:

Slide switch	RUN	Function settings can be viewed but Not modified.
	PROG (Program)	Function settings can be modified. As a safety feature, THE DOOR WILL NOT OPEN WHEN THE SLIDE SWITCH IS SET TO PROG.

PASS push button To select the next function

SET push button To change the present function value (when the slide switch is in PROGRAM mode).

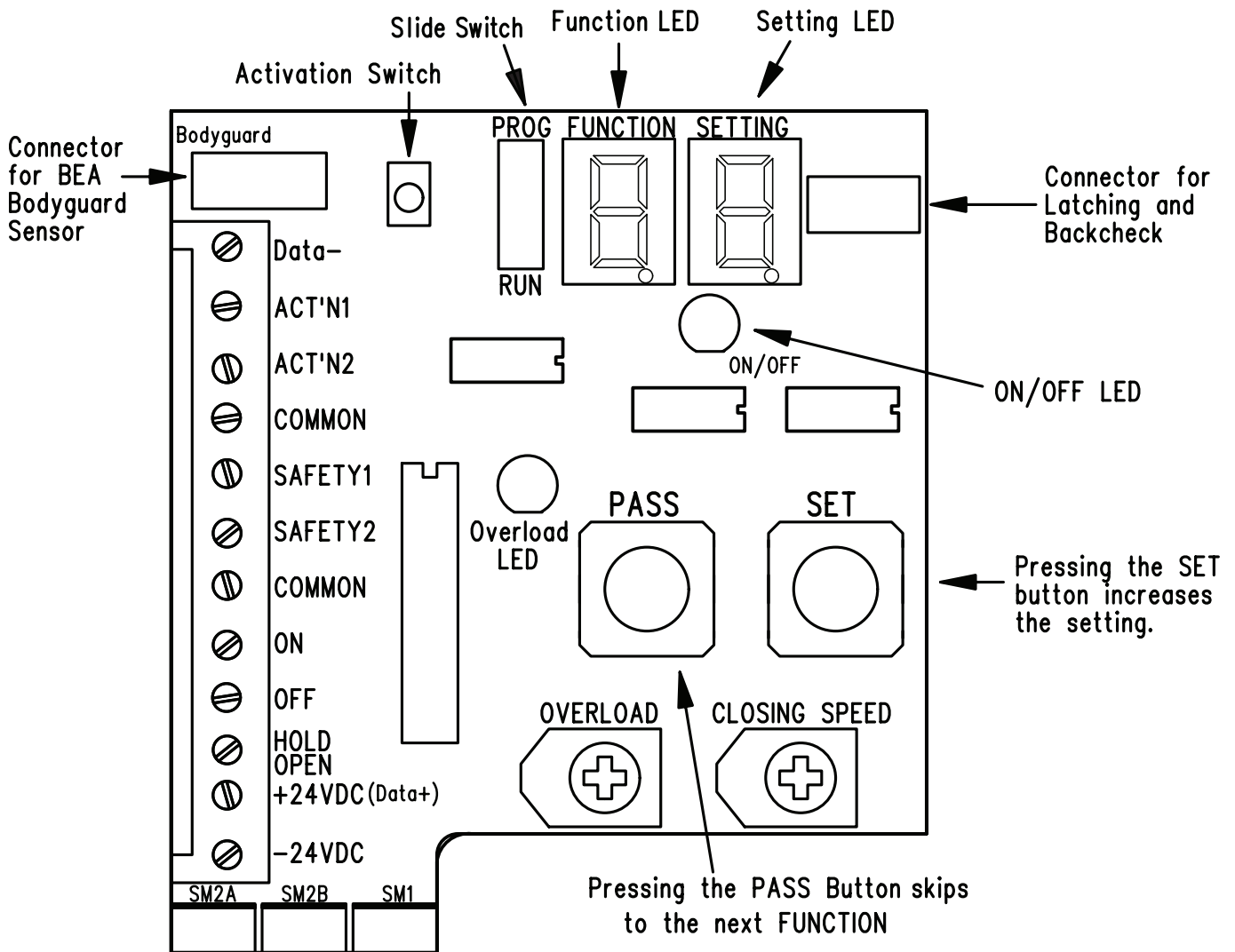

6.2 Connection Diagram - Low Energy (ANSI 156.19)

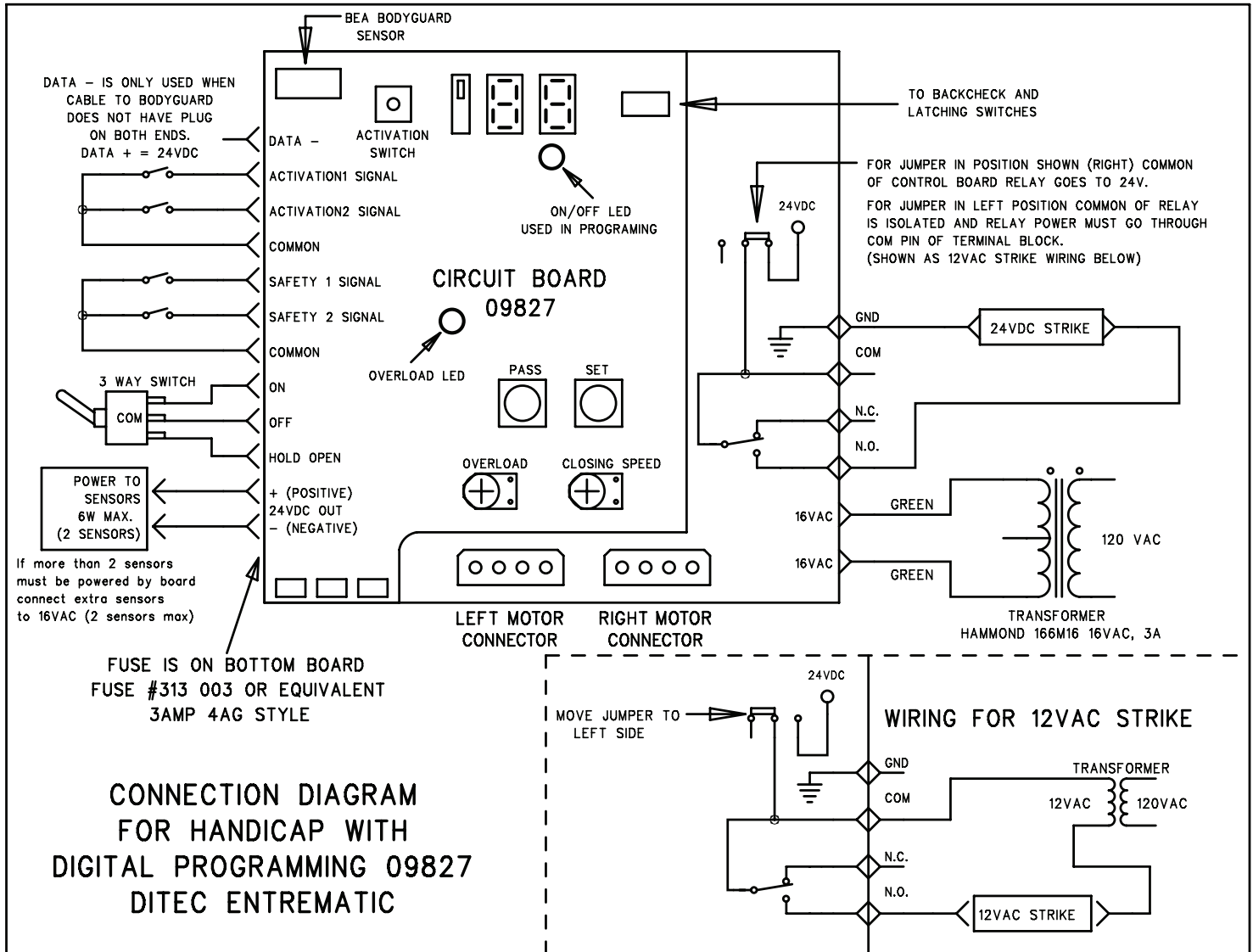

A Switch or Jumper must be wired from the ON terminal to the OFF terminal for Programming to work!

6.3 Connection Diagram - Fully Automatic (ANSI 156.10)

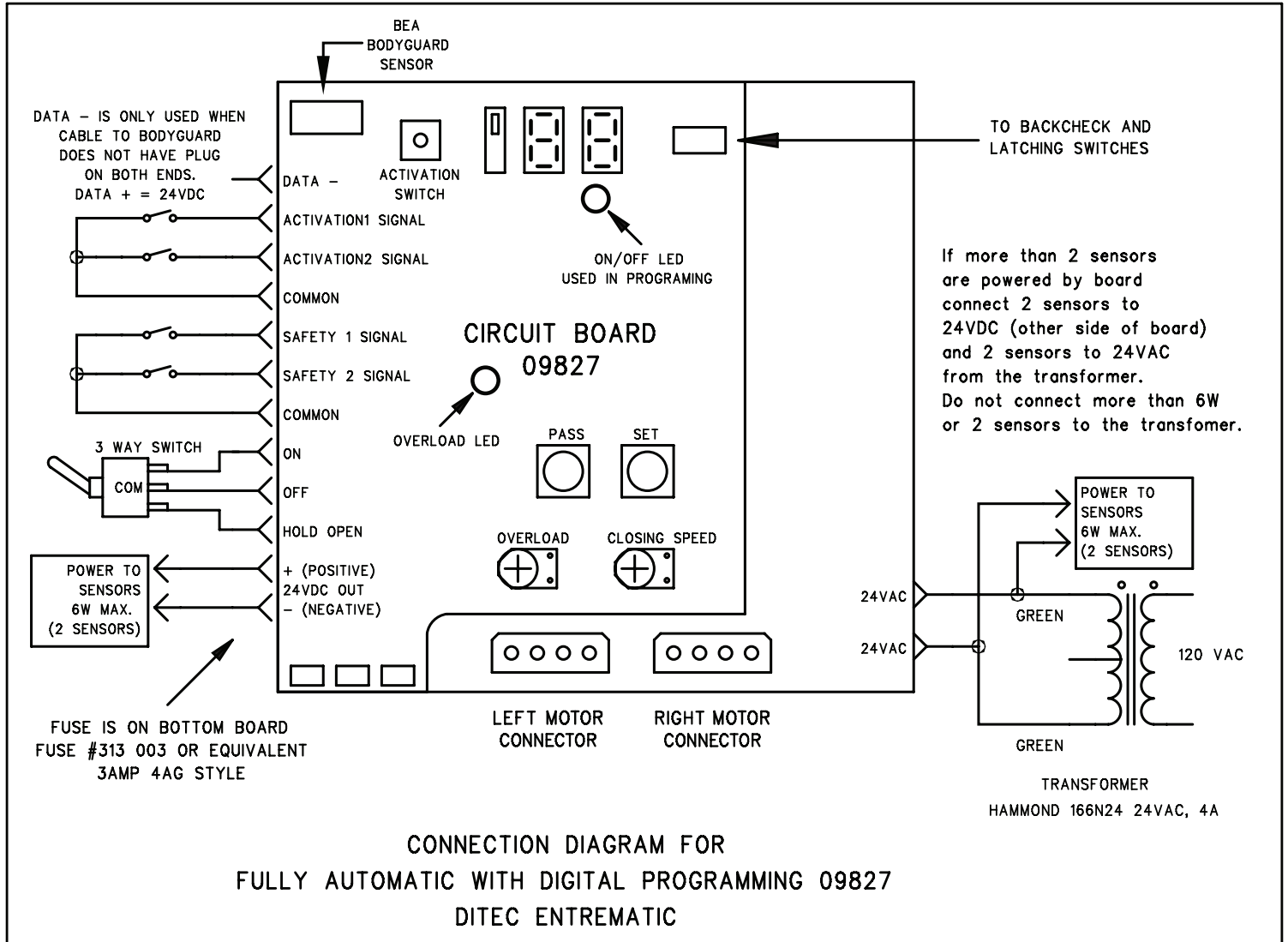

A Switch or Jumper must be wired from the ON terminal to the OFF terminal for Programming to work!

6.4 Programming Specification

FUNCTION LED	SETTING LED	FUNCTION DESCRIPTION	DEFAULT SETTING
0	0 to F 0 = slowest F = fastest	OPENING SPEED	A
1	0 to 5 0 = slowest 5 = fastest	BACK CHECK SPEED	1
2	0 to 5 0 = slowest 5 = fastest	LATCH SPEED	5
3	0 to 9 0 = slowest 9 = fastest	HOLD SPEED	2
4	1 = 2 sec 6 = 12 sec b = 22 sec 2 = 4 sec 7 = 14 sec C = 24 sec 3 = 6 sec 8 = 16 sec d = 26 sec 4 = 8 sec 9 = 18 sec E = 28 sec 5 = 10 sec A = 20 sec F = 30 sec	ACTIVATION TIME The time that the door remains open, starting when the activation trigger goes OFF. 2 to 30 sec	4
5	0 = 2 sec 4 = 10 sec 1 = 4 sec 5 = 12 sec 2 = 6 sec 6 = 14 sec 3 = 8 sec 7 = 16 sec	DELAY ON OPERATE The time delay before operating the door, starting when ACT'N2 trigger goes ON. 2 to 16sec - This is valid when Setting A1 has the LED OFF.	1
6	0 = Instant trigger - extremely sensitive 1 = 1/8 sec - very sensitive 2 = 1/4 sec 3 = 3/8 sec - mid range sensitivity 4 = 1/2 sec 5 = 5/8 sec - not sensitive	PUSH AND GO SENSITIVITY The amount of time that a push and go trigger must be sensed before the door is triggered. A longer time makes the door less sensitive to a push and go.	3
7	1 = 2 sec 6 = 12 sec b = 22 sec 2 = 4 sec 7 = 14 sec C = 24 sec 3 = 6 sec 8 = 16 sec d = 26 sec 4 = 8 sec 9 = 18 sec E = 28 sec 5 = 10sec A = 20 sec F = 30 sec	PUSH AND GO ACTIVATION TIME The time that the door remains open starting when the Push and Go input is triggered.	5
8	0 = 0.00 sec 1 = 0.50 sec 2 = 1.00 sec 3 = 1.50 sec 4 = 2.00 sec	SAFETY 1 INHIBIT The time that a Safety1 input is ignored (inhibited), starting when the door goes into Latch. 0 to 2 sec	0
9	0 = 0.125 sec 1 = 0.25 sec 2 = 0.50 sec 3 = 1.00 sec 4 = 1.50 sec 5 = 2.00 sec	STRIKE DELAY The time between Strike ON and door starting to open. HA board ONLY	0

CODE INDICATION		ON/OFF LED = ON	ON/OFF = OFF	DEFAULT SETTING
FUNCTION LED	SETTING LED			
A	0	Safety 2 OFF at Back Check	Safety 2 always active	LED OFF
A	1	ACT'N1 is connected to push button and always opens the door. ACT'N2 is connected to the door and is only active after ACT'N1 is pressed and before the door closes and gets to the Latch point.	ACT'N1 Instant activation ACT'N2 A delayed activation <i>(delay time programmed through Function A5)</i>	LED OFF ACT'N1 = instant ACT'N2 = delayed activation
A	2	Lockout ON – during closing Safety1 is active, if door stops moving (i.e. from hitting an obstruction). Safety1 is NOT active, if door is moving	Lockout OFF Safety1 is always active	LED ON Lockout ON
A	3	Push and Go is active. *It will only work with a door that DOES NOT have a clutch	Push and Go disabled	LED OFF Push and Go Disabled
A	4	Reading out numbers of door opening cycles	No readout	LED OFF No readout
	To obtain the number of opening cycles that the door has gone through, Press SET button while FUNCTION= A, SETTING= 4. Example: Readout of 3 2 (pause) 7 0 = 3,270 door cycles			
A	5	Safety1 sensor mounted on closing side of door	Safety1 sensor mounted overhead	LED OFF Safety1 mounted Overhead
A5 - LED OFF (Overhead Sensor)	Door Opening - Safety1 sensor has no effect Door Fully Open - Safety1 sensor ON = door will not close Door Closing - A2 setting ON. Door moving = Safety1 has no effect (door will open) - A2 setting ON. Door stopped, Safety1 ON = door will not open - A2 setting OFF. Safety1 ON = door will not open Door Fully Closed - Safety1 sensor ON = door will not open			
A5 - LED ON (Door mounted Sensor)	Door Opening - Safety1 sensor has no effect Door Fully Open - Safety1 sensor ON = door will not close Door Closing - Safety1 sensor ON = door drives at HOLD speed Door Fully Closed - Safety1 sensor has no effect			

CODE INDICATION		ON/OFF LED = ON	ON/OFF = OFF	DEFAULT SETTING
FUNCTION LED	SETTING LED			
A	0	Safety2 OFF at back check	Safety2 always active	LED OFF
A	1	ACT=N1 is connected to a push button switch and always opens the door. ACT=N2 is connected to the door and is only active after ACT'N1 is pressed and before the door closes and gets to the Latch point	Activation input 1 (ACT=N1) works as an instant activation. Activation input 2 (ACT=N2) works as a delayed activation (delay time programmed through Function A5@.)	LED OFF ACT=N1 is instant and ACT=N2 is delayed activation
A	2	Lockout ON – during closing Safety1 is active if the door stops moving (from hitting an obstruction for example). If door is moving then Safety 1 is NOT active.	Lockout OFF Safety1 is always active	LED ON Lockout ON
A	3	Push and Go is active	Push and Go disabled	LED OFF – Push and Go Disabled
** Push and Go will only work with an operator WITHOUT a clutch **				
A	4	In process of reading out A# of door opening cycles@	No readout	LED OFF – no readout
	<i>To obtain the number of opening cycles that the door has gone through press the set button while in the Function A, Setting 4 mode. Example: Readout of 3 2 (pause) 7 0 = 3,270 door cycles</i>			
A	5	Safety1 sensor mounted on closing side of door	Safety1 sensor mounted overhead	LED OFF – Safety1 mounted Overhead
A5 – LED OFF (Overhead Sensor)	Door Opening - Safety1 sensor has no effect Door Fully Open - Safety1 sensor ON = door will not close Door Closing - A2 setting ON. Door moving = Safety1 has no effect (door will open) - A2 setting ON. Door stopped, Safety1 ON = door will not open - A2 setting OFF. Safety1 ON = door will not open Door fully closed - Safety1 sensor ON = door will not open			
A5 – LED ON (Door mounted Sensor)	Door Opening - Safety1 sensor has no effect Door Fully Open - Safety1 sensor ON = door will not close Door Closing - Safety1 sensor ON = door drives at HOLD speed Door fully closed - Safety1 sensor has no effect			

CODE INDICATION		ON/OFF LED = ON	ON/OFF = OFF	DEFAULT SETTING
FUNCTION LED	SETTING LED			
A	6	Safety1 sensor is a Normally Closed input (N.C.)	Safety1 sensor is Normally Open input (N.O.)	LED OFF – Safety1 is Normally Open
A	7	Safety2 independent of ACT'N1 Safety2 is ON = door holds Safety2 is OFF = door opens	Safety2 works with Act'n1 For Safety2 AND Act'n1 both ON = door holds If Safety2 goes OFF = door opens If Act'N1 goes OFF = door closes	LED OFF Safety2 works with Act'N1
A	8	Fire door mode for California. Manually pulling the door closed while it is fully open will close the door ignoring all activation triggers including Hold Open. Turning to OFF resets this mode.**	Door will not shut when manually pulled closed	LED OFF
A	9	Safety monitoring ON for SM1. This monitors Safety1 input. See safety monitoring wiring and notes	Safety Monitoring OFF for SM1	LED OFF – No safety monitoring
A	A	Safety monitoring ON for SM2A. This monitors Safety2 input. See safety monitoring wiring and notes	Safety Monitoring OFF for SM2A	LED OFF – No safety monitoring

** When setting up A8, it is important to follow the steps below:

1. Turn the overload all the way down (counter clock wise for Analog Potentiometer)
2. Make sure Back Check speed is slow enough that it will not trigger the overload while the door is fully open.

RESET TO DEFAULT SETTING - Pressing both SET and PASS buttons for 5 seconds

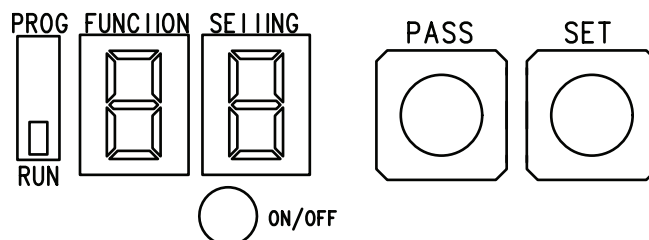

6.5 Digital Board Programming - Trouble Shooting

PROBLEM	POSSIBLE
Programming function does not work	<ol style="list-style-type: none"> 1. Make sure ON/OFF switch is connected. A switch must be connected from ON terminal pin to OFF terminal pin for programming to work 2. Slide switch must be set to PROG for programming options to be modified
Door does not open after being triggered	<ol style="list-style-type: none"> 1. Check power supply and is ON (7 segment LEDs will light up) 2. Slide switch should be set to RUN (switch is downward position) 3. Check which activation situation is selected. See setting A1 - If LED is ON for setting A1, ACT'N2 will only activate the door while it is closing and has not reached Latch 4. Check if ON/OFF switch is connected. A switch must be connected from ON terminal pin to the OFF terminal pin for the doors to open
Door does not open if triggered immediately after going into Latch	Increase the Safety1 inhibit time. See setting 8
Push and Go function does not work	<ol style="list-style-type: none"> 1. Only an operator WITHOUT a clutch will work for Push and Go Operators with a clutch cannot provide Push and Go 2. Check if Push and Go function enabled, See setting A3 3. Reduce Push and Go sensitivity, See setting 6
Door does not delay when triggered even when a delayed time has been set up	<ol style="list-style-type: none"> 1. See setting A1 - If LED is ON for program setting A1 this is a special activation situation and there is no delay 2. Only ACT'N 2 (Activation Trigger 2 input) will provide a delay on opening. ACT'N1 (Activation Trigger 1 input) and the push button on the board will ALWAYS give an instant trigger regardless of how the time delay has been set up
Door opens slowly	<ol style="list-style-type: none"> 1. Check to see if Back Check and Latching magnets are adjusted properly 2. Increase opening speed - Function 0

TESTING WITH OBSTRUCTION

For Optimum performance, door will open and push against obstruction for 2 sec then close. Adjust Overload according to door weight, size and site condition.

- For heavier doors – overload can be increased against weight resistance
- For lighter doors – avoid over setting of overload
- For external factors (door condition, wind, stack pressure) – Adjust overload according to each site condition.



If the problem persists, contact your authorized Ditec Entrematic representative for service!
Toll Free: 1-877-348-6837

6.6 Safety Monitoring

When Safety Monitoring is enabled the 09827 control board communicates with the safety sensor before every dangerous movement of the door to ensure that the Safety inputs are functioning correctly and all wires are in place. That is, before the door is opened and before the door is closed there is communication between the 09827 and safety sensor.



- A failed communication before opening will prevent the door from opening.
- A failed communication before closing will prevent the door from closing.
- For any failed communication the Overload LED will flash.

SETUP

- 1 Wire safety sensor to board as per wiring diagram below. Or according to the wiring diagrams for individual sensors in the pages to follow.
- 2 If not already done, enable for safety monitoring. For BEA sensors this must be done with the remote control.
- 3 Check to see that door opens.
- 4 In order to ensure that the safety monitoring setup has been done properly unplug the SM1 and/or SM2A connectors separately to see that the door does not open when triggered. (Overload LED will flash 1/3sec). Plug these connectors back into the board once this test is complete.

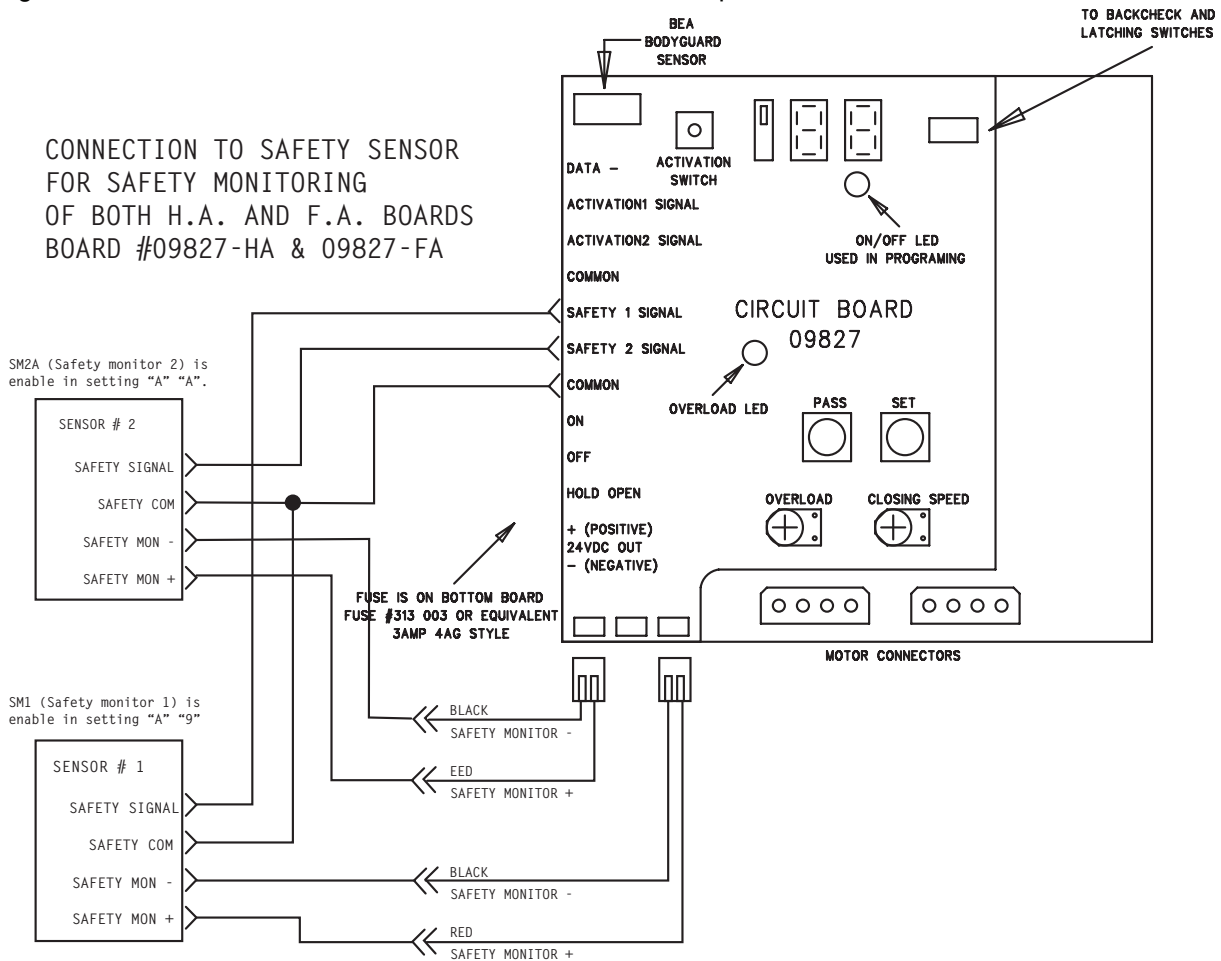

6.7 Safety Sensor Connection - BEA Bodyguard

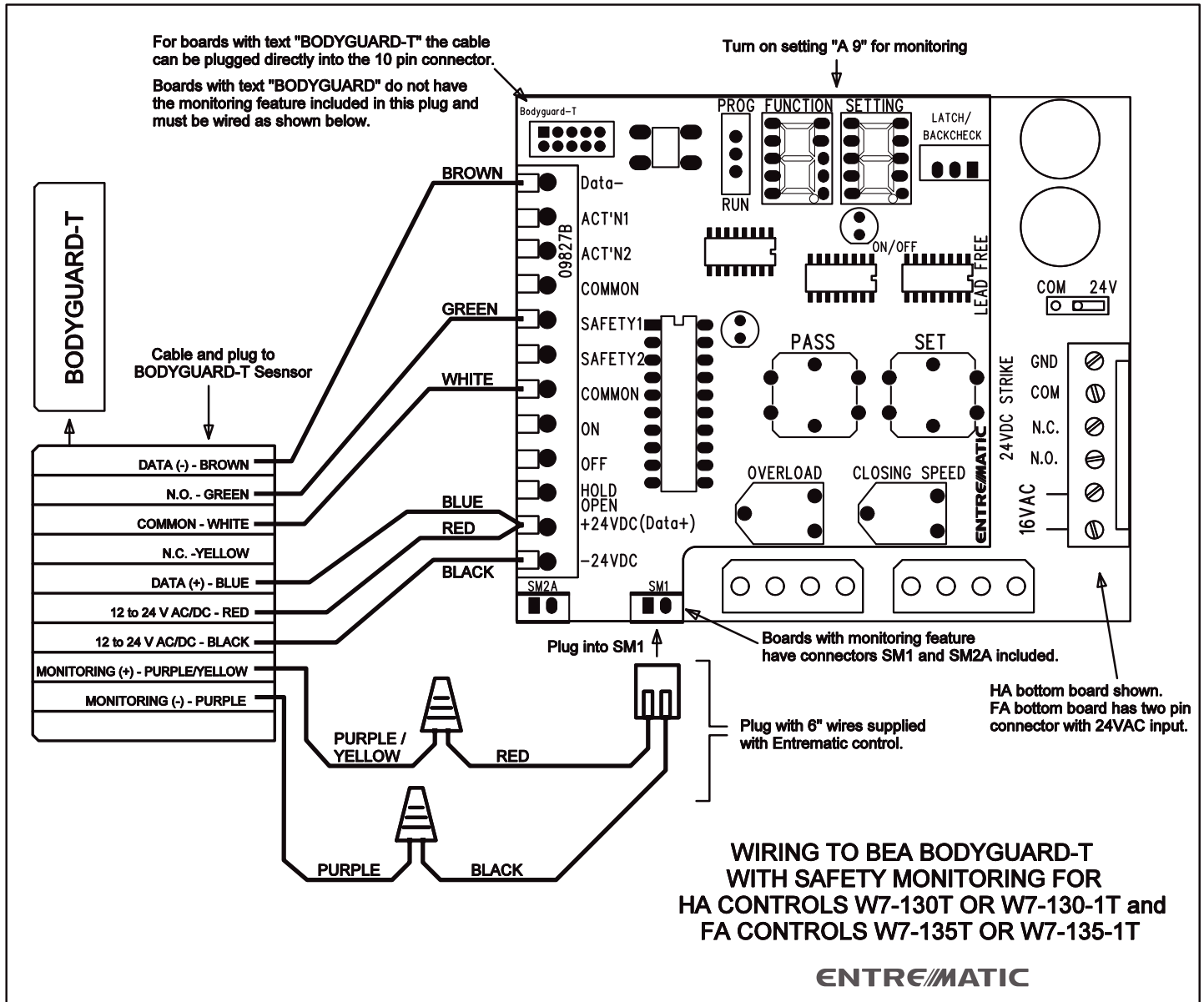

6.8 Safety Sensor Connection - BEA Superscan

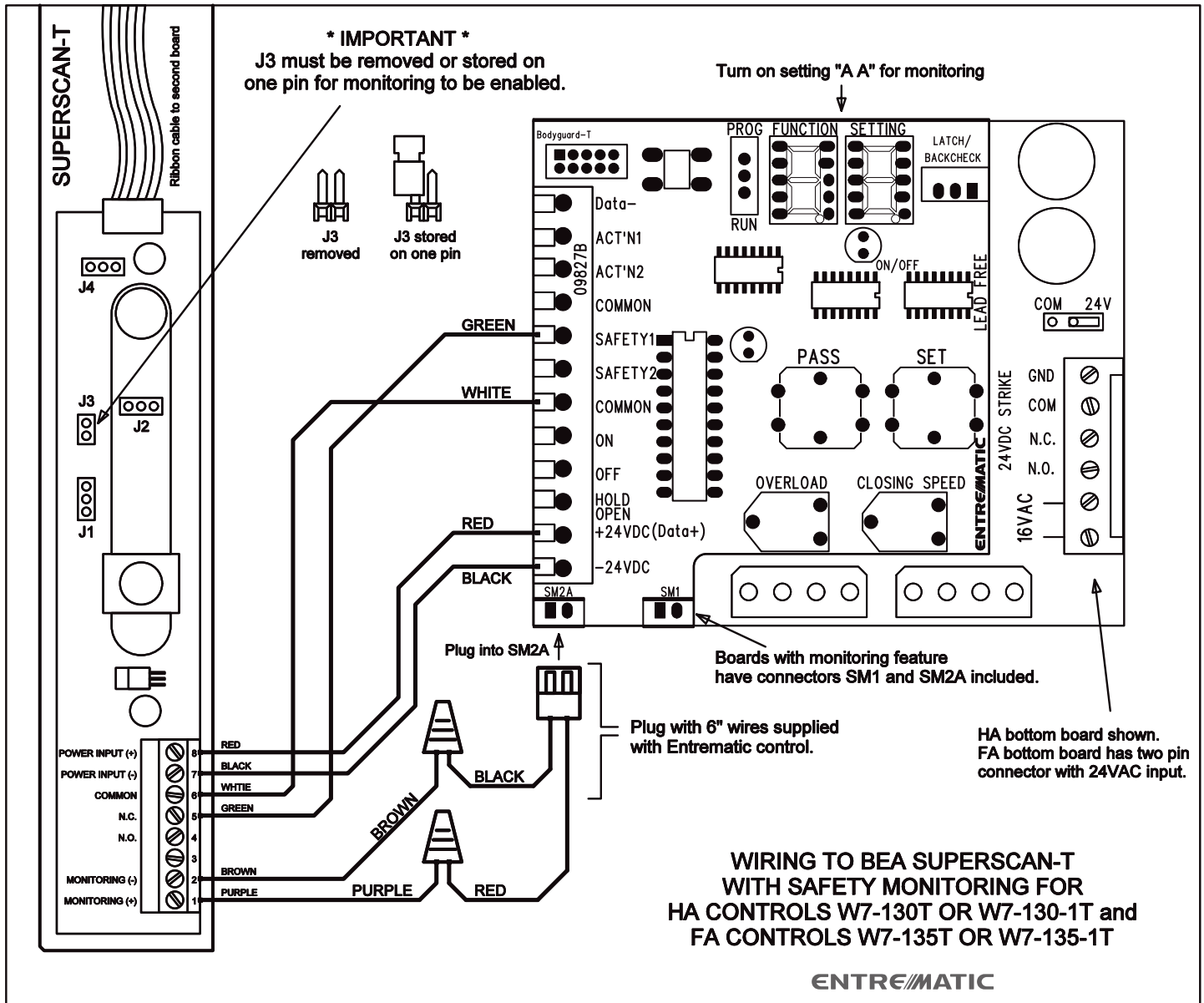

6.9 Safety Sensor Connection - Optex OA-FLEX

IMPORTANT NOTE:

For safety monitoring Test Input of OA-FLEX T must be set to Low.
 Test Input of OA-FLEX T is set through DIP 10 and should be UP.

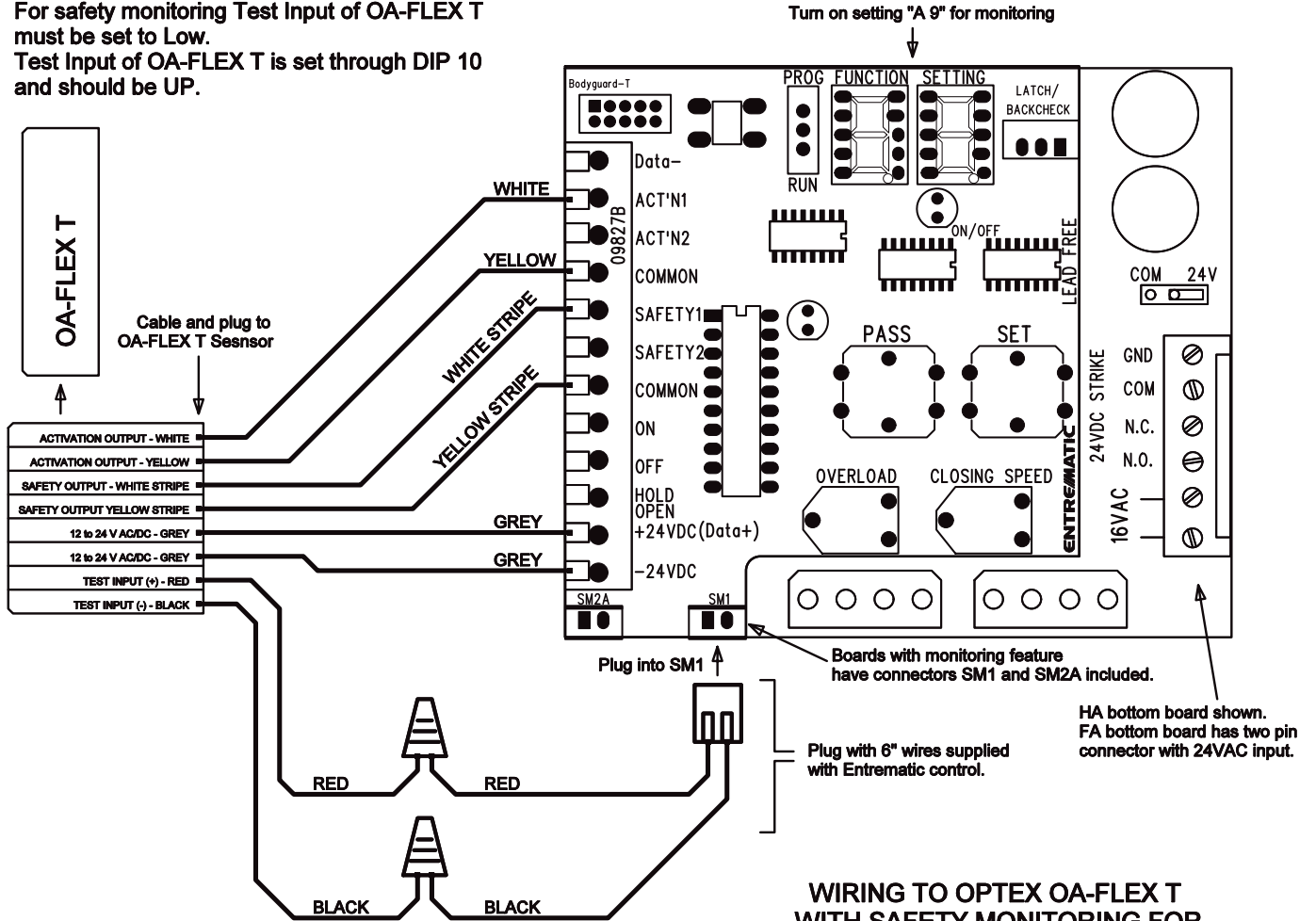

WIRING TO OPTEX OA-FLEX T WITH SAFETY MONITORING FOR HA CONTROLS W7-130T OR W7-130-1T and FA CONTROLS W7-135T OR W7-135-1T

ENTRE//MATIC

7.1 Dual Door Digital Board Specification (FA8 only)

INPUTS

	LINE VOLTAGE	TRANSFORMER (Hammond)
AC VOLTAGE	120VAC 60Hz	#166N24 – 24VAC – 4AMP
	240VAC 50Hz	#266N24 – 24VAC – 4AMP

ACTIVATION 1 (ACT=N1) - Single input for both doors. ON = Closed contact to ground/common.
- See setting C1 for operation description.

ACTIVATION 2 (ACT=N2) - Single input for both doors. ON = Closed contact to ground/common.
- See setting C1 for operation description.

SAFETY 1 - Single input for both doors. Closed contact to ground/common.
- For Safety1 ON (closed to ground) door will not open if presently fully closed and door will not close if presently fully opened.

SAFETY 2 - Single input for both doors. Closed contact to ground/common.
- For Safety2 ON (closed to ground) and activation input ON (closed to ground) door will drive at hold speed. If activation input goes off door closes. If Safety2 goes off door will open.

OUTPUTS

MOTOR - 2 motor connectors for each door (4 total).
- doors can drive in clockwise or counter clockwise direction.

DATA- and DATA+ - Interface with BEA Bodyguard sensor. (replaces LO-21K lockout relay)

OTHER FEATURES

SAFETY MONITORING Safety Monitoring is turned OFF as a default. To turn Safety monitoring ON see programming settings C8, C9, CA, and CB. Connection diagram on next page shows sensors wired in safety monitoring configuration.

CLOSING SPEED Adjustable by potentiometer. 1 potentiometer for each door
Power off does not affect closing speed

BACK CHECK SWITCH 1 switch for each door (Magnet and Reed switch)

LATCH SWITCH 1 switch for each door (Magnet and Reed switch)

LOCKOUT Each door has separate lockout which is selectable via Setting C2

OVERLOAD Each door has a non-adjustable overload.

HOLD OPEN SWITCH A switch wired one side to the HOLD OPEN quick disconnect tab and the other side to the OFF quick disconnect tab will open both doors and keep them open until the switch is turned off. *

ON SWITCH A switch wired one side to the ON quick disconnect tab and the other side to the OFF quick disconnect tab provides the door ON function. This switch, when open, disables the motors and all inputs but does NOT turn the board power off. *

** The Hold Open Switch and the ON Switch come wired to a single 3 position switch where the middle position gives Door OFF, one side provides Hold Open, and the last side provides Door ON or Automatic.*

7.2 Wiring Diagram

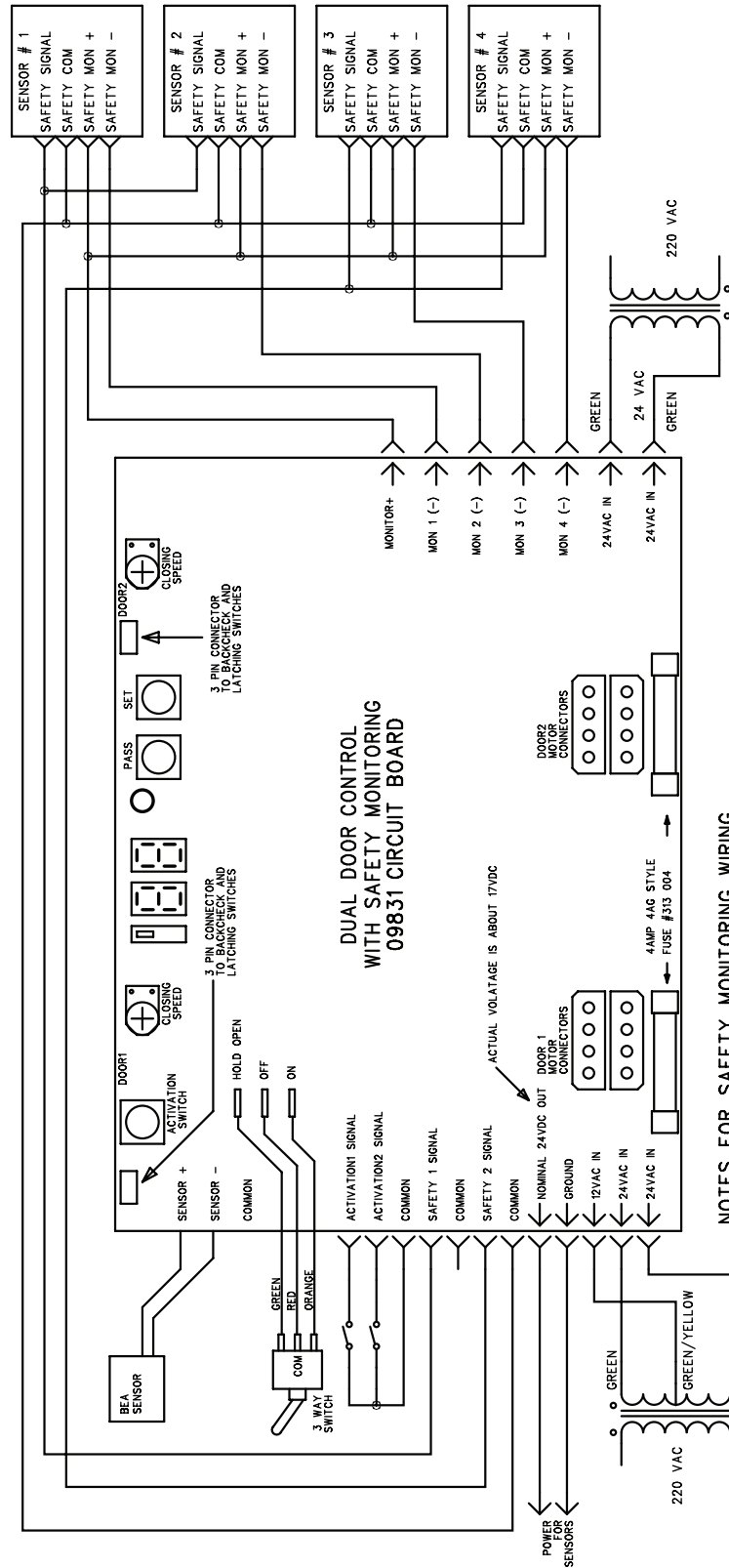

NOTES FOR SAFETY MONITORING WIRING

- ANY COMMON ON DOOR CONTROL CAN BE USED FOR SAFETY COMMON OF SENSOR
- SENSOR 1 AND SENSOR 2 ARE WIRED TO SAFETY 1 SIGNAL
- SENSOR 3 AND SENSOR 4 ARE WIRED TO SAFETY 2 SIGNAL

ENABLE OR DISABLE SAFETY MONITORING THROUGH FOLLOWING SETTINGS:

- SETTING "CB" = SENSOR 1
- SETTING "C9" = SENSOR 2
- SETTING "CA" = SENSOR 1
- SETTING "CB" = SENSOR 1

FOR ALL SAFETY MONITORING SETTINGS:

- LED ON = SAFETY MONITORING ENABLED
- LED OFF = SAFETY MONITORING DISABLED

COMPANY: ENTREMATIC	
TITLE: CONNECTION DIAGRAM FOR DUAL DOOR CONTROL WITH SAFETY MONITORING	DATE: May 10, 2012
CODE: 09831-WIRE-SM	DATE: March 7, 2016
SIZE:	REV: NC
DRAWING NO:	

7.3 Programming Specification

FUNCTION LED	SETTING LED	FUNCTION DESCRIPTION	DEFAULT SETTING
0	0 to F 0 = slowest F = fastest	OPENING SPEED DOOR 1	A
1	0 to F 0 = slowest 5 = fastest	OPENING SPEED DOOR 2	A
2	0 to 5 0 = slowest 5 = fastest	BACK CHECK SPEED DOOR 1	2
3	0 to 5 0 = slowest 5 = fastest	BACK CHECK SPEED DOOR 2	2
4	0 to 5 0 = slowest 5 = fastest	LATCH SPEED DOOR 1	5
5	0 to 5 0 = slowest 5 = fastest	LATCH SPEED DOOR 2	5
6	0 to 5 0 = slowest 5 = fastest	HOLD SPPEED DOOR 1	2
7	0 to 5 0 = slowest 5 = fastest	HOLD SPEED DOOR 2	2
8	1 = 1 sec 6 = 6 sec b = 12 sec 2 = 2 sec 7 = 7 sec C = 14 sec 3 = 3 sec 8 = 8 sec d = 15 sec 4 = 4 sec 9 = 9 sec E = 25 sec 5 = 5 sec A = 10 sec F = 30 sec	ACTIVATION TIME The time that the door remains open, starting when the activation trigger goes OFF. 1 to 30 sec	5
9	0 = 0.00 sec 1 = 0.50 sec 2 = 1.00 sec 3 = 1.50 sec 4 = 2.00 sec	SAFETY 1 INHIBIT The time that a Safety1 input is ignored (inhibited), starting when one of the doors go into Latch. 0 to 2 sec	0
A	0 = 0.00sec 4 = 1 sec 1 = 0.25sec 5 = 2 sec 2 = 0.50sec 6 = 3 sec 3 = .075sec 7 = 4 sec 8 = 5 sec	DELAY ON OPERATE DOOR 1 The time delay before operating door #1, starting when the activation # 2 trigger goes ON. 0 to 5sec Note that ACT=N1 input always provides an instant trigger while ACT=N2 input provides a delayed trigger.	0
b	0 = 0.00sec 4 = 1 sec 1 = 0.25sec 5 = 2 sec 2 = 0.50sec 6 = 3 sec 3 = .075sec 7 = 4 sec 8 = 5 sec	DELAY ON OPERATE DOOR 2 The time delay before operating door #2, starting when the activation # 2 trigger goes ON. 0 to 5sec. Note that ACT=N1 input always provides an instant trigger while ACT=N2 input provides a delayed trigger.	0
C	<i>Special Function selection - see next chart</i>		
D	0 = 0.00 sec 1 = 0.50 sec 2 = 1.00 sec 3 = 1.50 sec 4 = 2.00 sec	Delay on Closing One of the doors delays before closing for the chosen time. 0 to 2sec. Application Code AC4" states which door delays.	0

CODE INDICATION		LED 1 = ON	LED 1 = OFF	DEFAULT SETTING
FUNCTION LED	SETTING LED			
C	0	Safety 2 OFF at back check	Safety2 always active	LED OFF (Safety 2 always active)
C	1	ACT=N1 is connected to a push button switch and always opens the door. ACT=N2 is connected to the door and is only active after ACT=N1 is pressed and before the door closes and gets to the Latch point.	Activation input 1 (ACT=N1) works as an instant activation. Activation input 2 (ACT=N2) works as a delayed activation (delay time programmed through Function A5@.)	LED OFF ACT=N1 is instant; ACT=N2 is delayed activation
C	2	Lockout ON – during closing Safety1 is active if the door stops moving (from hitting an obstruction for example). If door is moving then Safety1 is NOT active.	Lockout OFF Safety1 is always active	LED ON (Lockout ON)
C	3	To obtain the number of opening cycles that the door has gone through press the set button while in the Function C, Setting 3 mode. Example: Readout of 3 2 (pause) 7 0 = 3,270 door cycles. The display will read - - at the end of readout		
C	4	Door 1 delays before closing for the amount of time setup in Function AD@	Door 2 delays before closing for the amount of time setup in Function AD@	LED ON (Door 1 delays)
C	5	Safety1 sensor mounted on closing side of door	Safety1 sensor mounted overhead	LED OFF – Safety1 mounted overhead
C5 - LED OFF (Overhead Sensor)		Door Opening - Safety1 sensor has no effect Door Fully Open - Safety1 sensor ON = door will not close Door Closing - C2 setting ON. Door moving = Safety1 has no effect (door will open) - C2 setting ON. Door stopped, Safety1 ON = door will not open - C2 setting OFF. Safety1 ON = door will not open Door fully closed - Safety1 sensor ON = door will not open		
C5 - LED ON (Door mounted Sensor)		Door Opening - Safety1 sensor has no effect Door Fully Open - Safety1 sensor ON = door will not close Door Closing - Safety1 sensor ON = door drives at HOLD speed Door fully closed - Safety1 sensor has no effect		

C	6	Safety1 sensor is a Normally Closed input (N.C.)	Safety1 sensor is a Normally Open input (N.O.)	LED OFF – Safety1 is Normally Open
C	7	Safety2 independent of Act'N1. Safety2 is ON = door holds Safety2 is OFF = door opens	Safety2 works with Act'N1. For Safety2 & Act'N1 both ON = door holds. If Safety2 goes OFF = door opens If Act'n1 goes OFF = door closes	LED OFF Safety2 works with Act'N1
C	8	SAFETY MONITOR 1 (MON 1) is ON Monitors SAFETY1 input	Safety Monitoring OFF for SM1	LED OFF – no safety monitoring
C	9	SAFETY MONITOR 2 (MON 2) is ON Monitors SAFETY1 input	Safety Monitoring OFF for SM2	LED OFF – no safety monitoring
C	A	SAFETY MONITOR 3 (MON 3) is ON Monitors SAFETY2 input	Safety Monitoring OFF for SM3	LED OFF – no safety monitoring
C	B	SAFETY MONITOR 4 (MON 4) is ON Monitors SAFETY2 input	Safety Monitoring OFF for SM4	LED OFF – no safety monitoring



A Switch or Jumper must be wired from the ON terminal to the OFF terminal for Programming to work!

RESET TO DEFAULT SETTING - Pressing both SET and PASS buttons for 5 seconds

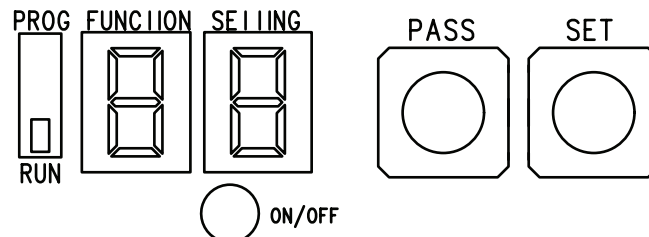

7.4 Programming - Trouble Shooting

PROBLEM	POSSIBLE
Door does not open after being triggered	<ol style="list-style-type: none"> 1. Make sure the power is connected and switched ON. Transformer which plugs into left side of board has <u>3 connections</u> including the center tap of the transformer. Transformer which plugs into right side has two connections. 2. Make sure the program / run switch is in the Arun@ mode. (switch down) 3. Make sure to select the Special activation situation. See setting C1 - If LED is ON for setting C1 the door only triggers when Activation input 2 goes ON and then Activation input 1 goes ON. 4. Make sure the On/Off switch is connected. A switch must be connected from the ON quick disconnect tab to the OFF quick disconnect tab for the doors to open.
Only one side of the door opens	<ol style="list-style-type: none"> 1. Check that both fuses are okay by measuring Zero resistance across them. (with power OFF) A blown fuse may not visually look like it is blown.
One side of the door opens a few inches and then closes	<ol style="list-style-type: none"> 1. Check the fuses as stated above. <i>Note: A small amount of power can feed from one side of the board to the other side even with a blown fuse. This gives the illusion that the fuse is okay as the door will actually open a few inches.</i> 2. Increase the activation time. See setting 8
Door does not have any power	<ol style="list-style-type: none"> 1. Make sure the transformer is connected properly. Transformer which plugs into left side of board has <u>3 connections</u> including the center tap of the transformer. Transformer which plugs into right side has two connections. 2. Check the fuse as above.
Door does not open if re-triggered immediately after going into latch	<p>Increase the Safety1 Inhibit time. See setting 9</p>
Door does not delay when triggered even when a delayed time has been setup.	<p>Only Activation Trigger 2 input (ACT=N 2) will provide a delay on opening. Activation Trigger 1 input (and the push button on the board) will ALWAYS give an instant trigger regardless of how the time delay has been setup.</p>



If the problem persists, contact your authorized Ditec Entrematic representative for service!
Toll Free: 1-877-348-6837

Low Energy Operator Adjustment to ANSI A156.19 standard

The following specifications are based on neutral air pressure conditions.

Opening Speed

Minimum opening time to back check or 80 degrees is 3 seconds or longer. Total opening time shall be 5 seconds or longer.

Closing speed

The minimum closing time to latch check depends on the size and weight of the door as follows:

Table I					
Minimum Opening Time to Back Check or 80 degrees (whichever occurs first) and Minimum Closing Time from 90 degrees to Latch Check or 10 degrees (whichever occurs first)					
"D" Door Leaf Width Inches (mm)	"W" Door Weight in Pounds (kg)				
	100 (45.4)	125 (56.7)	150 (68.0)	175 (79.4)	200 (90.7)
*30 (762)	3.0	3.0	3.0	3.0	3.5
36 (914)	3.0	3.5	3.5	4.0	4.0
42 (1067)	3.5	4.0	4.0	4.5	4.5
48 (1219)	4.0	4.5	4.5	5.0	5.5

* Check applicable Building Codes for clear width requirements in Means of Egress.

For doors of other weights and widths, use the formula below:

$$T = \frac{D \cdot \sqrt{W}}{188}$$

W = Weight of door (lbs)
 D = Width of door (Inch)
 T = Closing time to Latch Check (sec)

Latch check

The door must not close through the final 10 degrees in less than 1.5 seconds.

Adjustments for ADA (Americans with Disabilities Act)

Adjustments are provided for Opening speed, Back Check speed, Activation Time (Hold Open), Activation Delay, and Overload current with LED indicator.

Detection of an overload

Current is persisting for longer than 2 seconds will cause the door to close. See below recommended procedure for adjustment of the control:

1. Turn the Overload (current) control fully clockwise to increase the current limit to maximum and prevent any detection entirely. This setting can be used to inhibit the overload detection / shutdown feature.
2. Adjust Opening speed as desired. Note that the control has a built in time reference of 4.0 seconds. Operation of the door will not be affected. However, if the door moves from close to Back Check in less than 4.0 seconds, the LED will flash as the door closes to indicate that the Opening speed may be a little fast.
3. Lock or obstruct the door and apply an Activation Trigger. Turn the Overload control counter clockwise until the LED becomes steadily illuminated, to indicate detection of excessive current. The control may be turned counter clockwise a little more to ensure positive detection. After 2 seconds the door will close.
4. Adjust the Activation Time (hold open) as desired, Minimum of 5 seconds.
5. Adjust the Activation Delay time as desired. This will depend on the distance of the activation devices to the door.

(Updated Nov 2017)

9.1 Additional Components: Sensor(s) / Knowing Act Devices

Safety Sensors

The control board can accommodate overhead and door mounted safety sensors. To permit safe passage through, the closing door will reverse (if equipped with door mounted safety sensor) to full open position, if an obstruction is encountered during the closing phase. If equipped with door monitor sensor, the operator will then resume its standard closing cycle and repeat when the obstruction remains.

- If equipped, the safety sensor on the closing side of the door will activate while the door is closing. The door will reverse to open.
- If equipped, the safety sensor on the opening side of the door is activated by another pedestrian while the door is opening, the door will stall until that pedestrian has left the opening area.
- If the door is equipped with an overhead safety sensor, the door will not open when there is an obstruction or pedestrian in the swing path.
- If the door is equipped with an overhead presence sensor in the closed position, the door will not open when there is an obstruction or pedestrian in the swing path.

Activation Devices

The HA8-SP Operator is compatible with all devices using a dry contact switch, usually hardwired or radio controlled. All activation signals should be wired to Activation 1 and Common. When a door is used in a vestibule the built-in sequence can be used to allow both doors to operate in sequence. This is achieved by wiring Activation 2 and common on both boards together. The delay at which the second door opens after the first door opens is set using Function 5 on the programming schedule, up to 5 sec delay is achievable.

Jamb mounted switches

It can be used but are not practical for individuals using a wheelchair because of their range of motion (positioning their wheelchair to clear the door opening). (See Section 1.5) In a vestibule entrance a switch must be installed in the vestibule space to prevent entrapment and the doors can be sequenced to ease the traffic flow and limit the time of both doors being open to outside weather conditions.

Push Plate or Knowing Act Devices

- Test the knowing act device. The door should swing smoothly to the open position and stop without impact. After a time delay (normally 1 sec to 5 sec) the door should close smoothly.
- Repeat on the other side of the opening if the door has two-way operation.
- If there is more than one push plate or Knowing Act Device on each side of the door, each should be tested.

Electric Strike

The HA8-SP Operator control board is capable of supplying power (24VDC, 6W or 250 mA) to the electric strike. The power is supplied from the board on an ADA unit. When the door is triggered a contact closure occurs across Ground and N.O. or N.C. to energize the strike. The contact closure is applied 200 msec. Before door activates and continues for 2 seconds after the door begins to open, the electric strike operation is achieved by connecting 24 VDC to Strike in (terminal 4 to terminal 5 of the terminal block) and connecting the strike power wires to Strike out (terminal 6) and Ground (terminal 3). The strike has a delay function from 0.125 seconds - 2 seconds.

Digital Board connection – N.O. + GND



FA8 Fully automatic boards do not support electric strike.

9.2 Header Cover Installation

After all adjustments have been finished, the header cover must be installed to the header box. Fasten to the body and operator using (4) screws. The Header Cap can then be placed to complete the install.

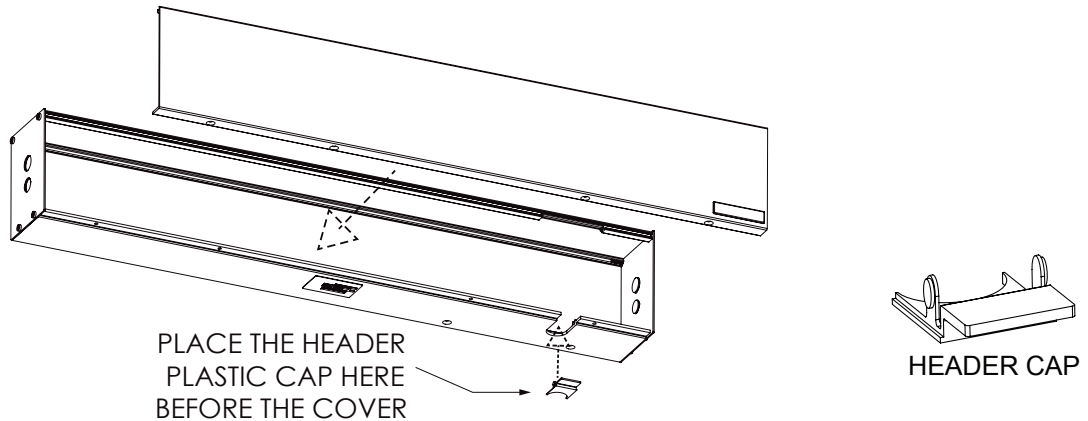

9.3 Safety Decals

Install all safety, traffic control, and instruction decals to the door as required. This is very important. Failure to do this leaves the installer **LIABLE** for any accident that might occur. This must be done!

A summary of the ANSI standard 156.19 requirements for safety decals is as follows:

Each decal shall be mounted on the door at a height of 58 ± 5 " (1470 \pm 130 mm) from the floor to the center line of the sign. The sign chosen will depend on the classification of the door operator.

Clean the area well before applying the decal. Remove the upper portion of the backing and roll the decal onto the door in a slow motion. Check to confirm the decal is straight. Use a flat edged soft spreader to smooth out the decal. Remove the lower backing from the decal and smooth out any air pockets.

After all adjustments have been finished, the face cover must be installed to the back plate by snapping cover into position.

Safety Sticker Placement Example

The center of the sticker height should be between 38" [965 mm] and 62" [1574 mm], above the finished floor. See ANSI standard 156.19 requirements for additional safety decal information.

**LOW ENERGY STICKERS
(ON BOTH INGRESS
& EGRESS SIDES)**

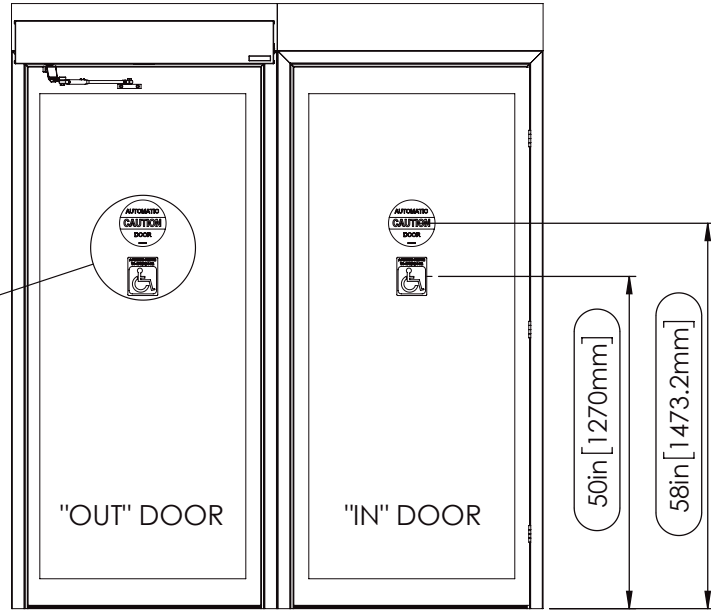
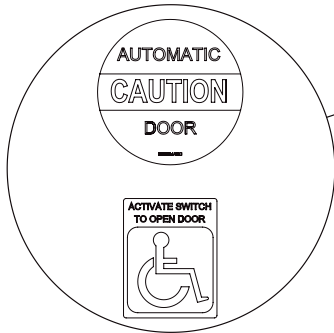

**FULL ENERGY STICKERS
(INGRESS SIDE)**

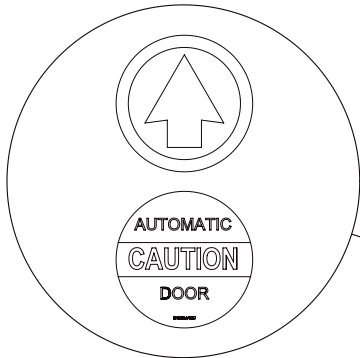

**FULL ENERGY STICKERS
(EGRESS SIDE)**

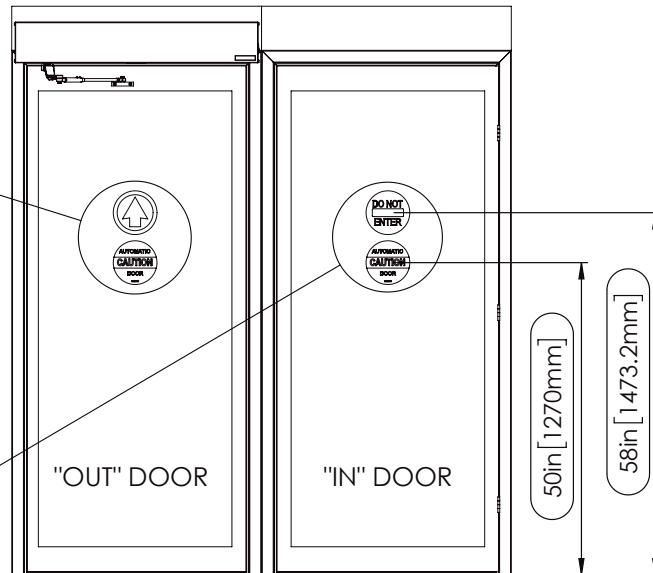
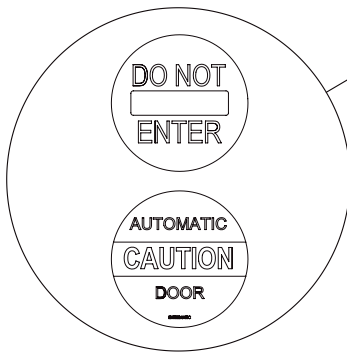

WARNING! Before leaving the job site,

- Clean up the work area
- Clean glass
- Make sure all bolts are tight
- Install safety decals

Manufacturer and Shipping Address**Entrematic Canada Inc.**

221A Racco Parkway,
Vaughan, ON,
L4J8X9
Toll Free: 1-877-348-6837
Email: info.ditec.ca@entrematic.com

Entrematic USA Inc.

Shipping (Returns Materials)
1310 Airport Road, Unit C,
Monroe, N.C.
28110
Toll Free: 1-866-901-4284
Local: 704-290-0980
Fax: 704-919-5014
Email: info.ditec.us@entrematic.com

Series Model: HA8-SP**HA8-SP Installation Manual Item# W5-645****Codes and Standards**

The operator complies with the following codes and standards:

- UL STD.325 & ANSI/BHMA STD. A156.19; Fire rated UL STD. 10 (b); UL STD. 10(c); NFPA STD. 252
- CAN/CSA STD. C22.2 NO. 247 & CAN/ULC STD. S104

All the rights concerning this material are the exclusive property of Entrematic Group AB.

Although the contents of this publication have been drawn up with the greatest care, Entrematic Group AB cannot be held responsible in any way for any damage caused by mistakes or omissions. We reserve the right to make changes without prior notice.

Copying, scanning or changing in any way is expressly forbidden unless authorized in writing by Entrematic Group AB.

Ditec

ENTRE//MATIC

Entrematic Canada Inc.

Toll Free: 1-877-348-6837
info.ditec.ca@entrematic.com
www.ditecentrematic.ca

Entrematic USA Inc.

Toll Free: 1-866-901-4284
info.ditec.us@entrematic.com
www.ditecentrematic.us