

Ditec DS18C

Installation Instructions

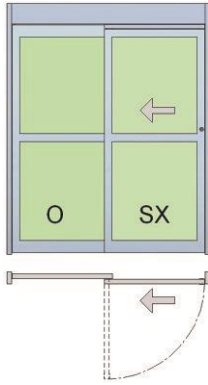

Left fixed side light

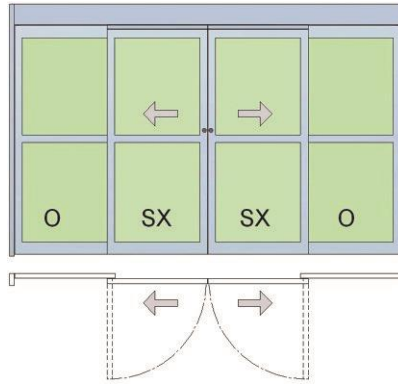

Bi-part fixed side light

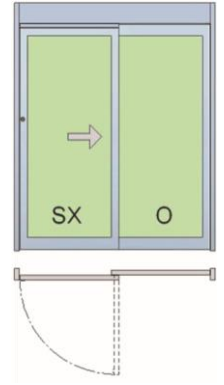

Right fixed side light

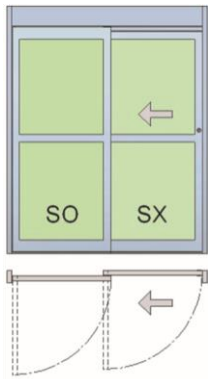

Left full breakout

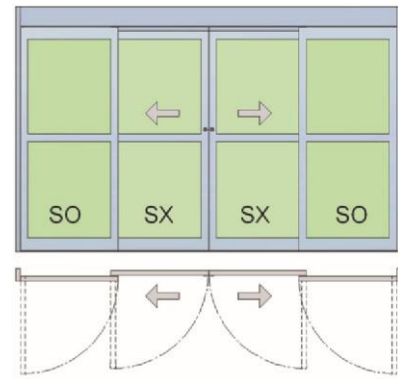

Bi-part full breakout

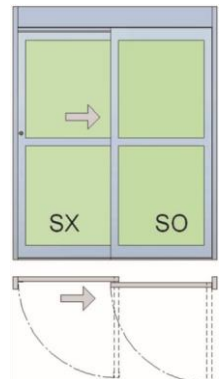

Right full breakout

WARNING! To reduce the risk of severe injury:

- ⚠️ READ AND FOLLOW ALL INSTALLATION INSTRUCTIONS CAREFULLY! FAILURE TO DO SO MAY RESULT IN PERSONAL INJURY OR PROPERTY DAMAGE!
- ⚠️ Do not connect the opener to a power supply until instructed to do so. Connection of the high voltage supply should be done by **a qualified professional** and within the guidelines of the **enforced local electrical codes**.
- ⚠️ Note: HIGH VOLTAGE (INCOMING 115 VAC) WIRES AND LOW VOLTAGE WIRES CANNOT SHARE THE SAME ACCESS HOLE. HIGH VOLTAGE WIRES MUST BE ROUTED AND SECURED AWAY FROM ALL LOW VOLTAGE WIRES.
- ⚠️ Test all safety features before turning over the equipment to the customer.

Entrematic Canada Inc.
 221A Racco Parkway
 Vaughan, Ontario, Canada
 L4J 8X9
 Tel 416-674-8880
 info.ditec.ca@entrematic.com

Entrematic USA Inc.
 1405 Parkway View Drive
 Pittsburgh, PA, USA
 15205
 Tel 866-901-4284
 www.entrematic.com

www.ditecentrematic.ca



Ditec DS18C

The Ditec Automatic sliding door model DS18C is an electromechanical sliding entrance system, factory assembled and tested.

The operating system is complete inside the header and doors are ready to hang.

The installer has to simply follow the sequence below:

- ✍ Bolt side jambs to the header
- ✍ Fit and fasten side jamb and header assembly in door opening
- ✍ Secure bottom guide track, hang doors and sidelites
- ✍ Connect power supply to operator and wire in any activating devices
- ✍ Glaze doors and align height
- ✍ Final adjustment of door speed and operation **to conform to ANSI Code**

Shipping Inspection

Verify that the order was shipped complete and correct, including model number, colour, and job width and height.

NOTE: If any of the below items are not correct, **do not attempt to install the DS18C Sliding Door Package!**

Report any correct items to the general contractor **immediately**. Do not proceed until all conditions are correct.

Table of Contents

Contents

Ditec DS18C.....	2
Shipping Inspection.....	2
Table of Contents.....	3
Specifications.....	4
Installing the Frame.....	5
SITE PREPARATION.....	5
HEADER AND JAMB MOUNTING.....	5
FULL THRESHOLD INSTALLATION.....	6
PARTIAL THRESHOLD INSTALLATION.....	6
Installing the Panels.....	7
BREAKAWAY SLIDELITE PANEL INSTALLATION.....	7
FIXED SLIDELITE PANEL INSTALLATION.....	7
INSTALLATION OF THE ACTIVE DOOR(S).....	8
Systems with Breakaway Sidelite.....	8
Systems with Fixed Sidelite.....	9
Electrical.....	10
Set-up and Adjustment.....	18
DOOR HEIGHT.....	18
CENTERING THE DOORS.....	18
ADJUSTING THE BELT TENSION.....	18
CONTROL BOX SET-UP.....	18
LED (LIGHT EMITTING DIODE) DISPLAY.....	19
ADD-ON FUNCTIONS.....	19
OPTIONAL EXTRAS.....	19
SETTING OF OPENING DIRECTION.....	19
PROGRAMMING CODES AND VALUES.....	20
BASIC CODE TABLE: SPEED/FORCE/TORQUE.....	21
APPLICATION CODE TABLE.....	22
HALF OPEN ADJUSTMENT DESCRIPTION.....	23
TEACHING STROKE.....	23
ERROR CODE TABLE.....	23
Troubleshooting By Error Code.....	24
HELPFUL TROUBLESHOOTING HINTS.....	25
Warning Labels.....	26
Replacement Parts.....	26

Specifications

Model		Ditec DS18C
Applicable door (Max.)	Dimensions	1219 (W) x 2134 (H)
	Weight	90 kgf x 2
Power supply and power consumption		100V AC±10V, 50/60Hz, 150W (max)
Manual door opening/closing force during power failure		22.5N to 33.3N (2.3 kgf to 3.4 kgf)
Rated operation		Continuous opening and closing cycles
Door opening/closing speed		100 mm/sec. to 750 mm/sec. 16 speed steps adjustable
Door opening/closing force		High: 216N (22 kgf), Low: 176N (18 kgf) 10 steps adjustable
Motor		Brush less molded DC motor
Reduction gear		Enclosed hypoid gear system
Control system		Microprocessor control
Braking stroke adjustment		Automatic adjustment
Door opening time		0 sec. to 30 sec. (8 steps adjustable)
Elimination of door to frame gap		Electric pressure at low voltage Pressing force is 49.0N (5 kgf) 5 steps adjustable
Safety functions		Blocked when opening: safety stop (alarm) Blocked when closing: high speed reverse opening then low speed closing (alarm) or safety stop (switchable)
Failure detection		Alarming on failure detection: automatic reset by sensor signal or after 15 sec.
Energy saving		10 step half open operation 13% to 98%
Emergency door opening/closing		Possible when an emergency signal is received. (24V battery pack is required)
Electro-magnetic lock system		Optional addition
Operating environment		Ambient temperature: -20°C to +50°C (no condensation or icing) Ambient humidity: 30% to 85% RH (no hazardous materials must be present in the atmosphere)
Insulation residence		10MÙ or more at 500V DC
Dielectric strength		1000V AC for 1 minute

Installing the Frame

SITE PREPARATION

Verify at job site that all conditions are correct and in accordance with final approved shop drawings.

1. Check that the floor is level. Use a minimum of 6'-0 (1829 mm) level or use the actual aluminum header **turned upside down** to check floor.
2. Be sure the opening is plumb and square, and is sized in accordance with approved shop drawings or architectural details. Use a plumb bob, check that the rough opening where the jambs will be mounted is vertical and that the diagonal measurements are a true rectangle, not just a parallelogram.
3. The finished opening width (F.O.W.) should be 1/2" wider than the overall frame width (O.F.W.) and the finished opening height (F.O.H.) should be 1/4" higher than the overall frame height (O.F.H.) of the sliding door system. **Caution:** The finished floor must be determined prior to setting the jambs and support beam. The jamb and threshold sit on the finished floor.
4. Check that the electrical feed (110V, 15A single phase), all conduits, electrical junction boxes (for push plates or other activation devices, if required) are correctly located in accordance with final approved shop drawings and **within the guidelines of the enforced local electrical codes.**

HEADER AND JAMB MOUNTING

1. Remove the header from the box and set on a piece of cardboard with the swing cover facing up. Open the access cover.
2. Inside the header is the motor/gearbox with drive pulley, belt drive, idler pulley and tensioning assembly, control box, transformer, safety beam control box (optional), any switches and the terminal block bracket.
3. Align the jamb tubes with the ends of the header, making sure that the bolt holes and electrical feed hole line up. Use the supplied 1/4-20 x 1" hex bolts on each side to secure the header end cap to each jamb tube.
4. Power supply may be pulled into the header at the same time the jamb/header assembly is positioned. This should be done by a **certified electrician** and within the guidelines of **the enforced local electrical codes.**
NOTE: HIGH VOLTAGE (INCOMING 115±5VAC) WIRES AND LOW VOLTAGE WIRES CANNOT SHARE THE SAME ACCESS HOLE. HIGH VOLTAGE WIRES MUST BE ROUTED AND SECURED AWAY FROM ALL LOW VOLTAGE WIRES. USE STICK ON WIRE CLIPS SUPPLIED.
5. With two people, flip up the jamb/header assembly and position it in the rough opening. Check that the cover is on the correct side. Confirm that the unit is in the proper position within the rough opening (as shown by the shop drawings). The Ditec DS18C Sliding Door Package is usually centred within the opening or is mounted flush with the curtain wall, but verify the position with the drawings, contractor, architect, etc.
6. Insert shims at each jamb to plumb each jamb. Insert 1/4" (6 mm) spacers around the header or horizontal transom tube at anchor locations to keep the tubes from being pulled tight. Use appropriate fasteners (four per jamb) to anchor through the glazing recess of the jamb tube to the wall or adjacent framing. Check the jamb tubes with a level to be sure that the anchors are not pulling them in. The standard package height is 91 1/2" (2318 mm).

FULL THRESHOLD INSTALLATION

NOTE: The DS18C has a special threshold that allows the ramping lip to be snap off on site, to allow flooring material to butt up to the threshold.

1. Prior to drilling, verify that the panel pivot groove in the threshold is on the proper side of the opening and that the threshold is level in both directions. Use the appropriate fasteners to secure the threshold to the floor. Do not mount screws in the door guide travel area.

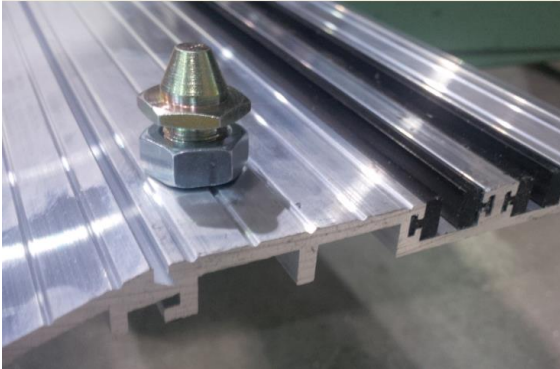

Figure 1

2. The side panel bottom pivot is installed in the threshold and can be adjusted for height (*Figure 1*). If the threshold filler is not installed, it can be tapped-in with a wood block and rubber mallet.

PARTIAL THRESHOLD INSTALLATION

1. Begin installation of the bottom guide (floor portion) by snapping a chalk line between the side jambs on the interior face of the jambs. This straight reference line will be used to locate the bottom guides.
2. Prior to drilling, verify that the panel pivot groove in the threshold is on the proper side of the opening and that the threshold is level in both directions. Use the appropriate fasteners to secure the threshold to the floor. Do not mount screws in the door guide travel area.

NOTE: THE BOTTOM SIDELITE GUIDE MUST BE LEVEL AND ALIGNED PARALLEL TO THE JAMBS TO INSURE PROPER OPERATION OF THE DOOR.

Installing the Panels

BREAKAWAY SLIDELITE PANEL INSTALLATION

1. Remove panels from carton. Lift panel and place bottom pivot bushing (factory installed in bottom panel stile) onto the track pivot (*Figure 1*). Raise the top pivot pin in the header and place the panel into position. Push the pivot pin in the header down to engage the panel pivot bushing in the top of the panel style (*Figure 2*).

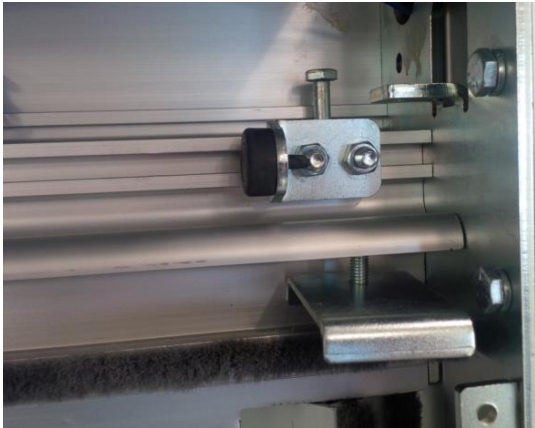

Figure 2

2. Adjust bottom pivot to give the required 1/8" (3 mm) clearance at the top of the panel. The panel may have to be removed to reach track pivot.

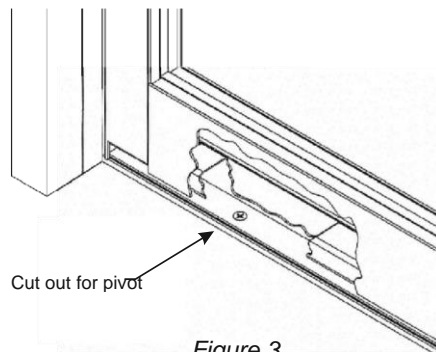

Figure 3

FIXED SLIDELITE PANEL INSTALLATION

1. Secure the sidelite J-mould track to the floor or threshold, being sure it is tight to the jamb, plumb, square and level (*Figure 3*).
2. Place the sidelite over the J-mould track and position tight to the jamb and plumb.
3. Secure the top of the track to the header flange with screws inserted from the interior side of the header (*Figure 4*).

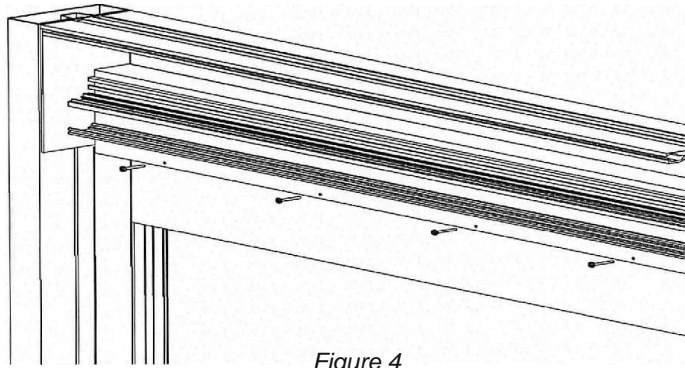
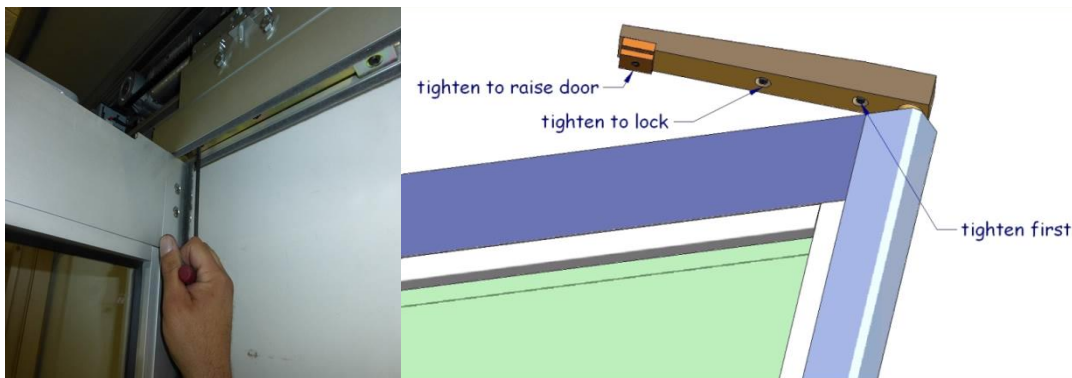

Figure 4

INSTALLATION OF THE ACTIVE DOOR(S)

Systems with Breakaway Sidelite

1. Check to see that the active door supplied with the sliding door system is complete and that all mounting screws are too tight.
2. Turn the carrier portion of the PSA hardware 90 degrees to the active door and slide it into the door carrier extrusion. **Do not leave out the adjusting block.** Position the carrier portion of the PSA to line up with the end of the panel style and secure the first Allen set screw beside the PSA pivot shaft; this locks the PSA in position. Use the Allen screw in the adjusting block to bring tension on the PSA. This adjustment is to remove the sag of the panel in the break out position with the weight of the glass on the hinge (*Figure 5*). **The final adjustment cannot be made until glass is installed.** The middle set screw is used to lock the PSA in place. Slide the door carrier portion of the ball catch assembly into the door carrier extrusion and position the ball catch, but do not tighten the setscrews. Slowly close the active leaf and position the carrier portion of the ball catch so that it passes through the cut out in the active leaf and engages the door portion of the ball catch. Mark the position of the ball catch on the carrier and secure the two setscrews.



3. Check the amount of force required to breakout the active leaf (**no more than 50 LBF**), and then adjust the tension, if necessary. The tension on the ball catch can be adjusted by the Allen set screw until the desired tension is obtained.

Systems with Fixed Sidelite

The active door in a fixed sidelite system mounts the same as a breakaway sidelite on the door carrier except the door guide track is mounted inside the sidelite instead of on the threshold.

1. Slide the lower pivot wheels into the 2" x 2" cut out on the bottom of the fixed sidelite panel (see *Figure 3*).
2. Install the foam bumpers on both sides of the carrier assembly as shown in *Figure 6* and swing the active leaf closed until the ball catch is engaged.



Figure 6

Electrical

Once the doors are installed, the main power supply to the unit may be connected. This should be done by a **certified electrician** and **within the guidelines of the enforced electrical codes**.

The Ditec DS18C requires 115 +/- 5VAC (black and white) power supply which by means of a step-down transformer providing the main controller with 100 VAC (black and red) and 24 VAC (green wires) for the auxiliary options.

Note: Installation of any extra wiring for controls or accessories into the header unit shall be secured out of the way of all moving parts and any sharp edges.

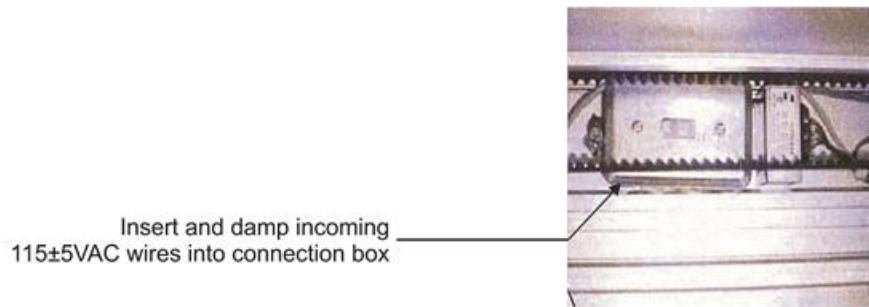

Figure 7

NOTE

THE GROUND WIRE FOR THE INCOMING 115±5VAC POWER AND THE SYSTEM GROUND WIRE CANNOT SHARE THE SAME GROUNDING STUD. GROUND THE INCOMING 115±5VAC ACCORDINGLY.

NOTE

HIGH VOLTAGE (INCOMING 115±5VAC) WIRES AND LOW VOLTAGE WIRES CANNOT SHARE THE SAME ACCESS HOLE. HIGH VOLTAGE WIRES MUST BE ROUTED AND SECURED AWAY FROM ALL LOW VOLTAGE WIRES. USE STICK ON WIRE CLIPS SUPPLIED.

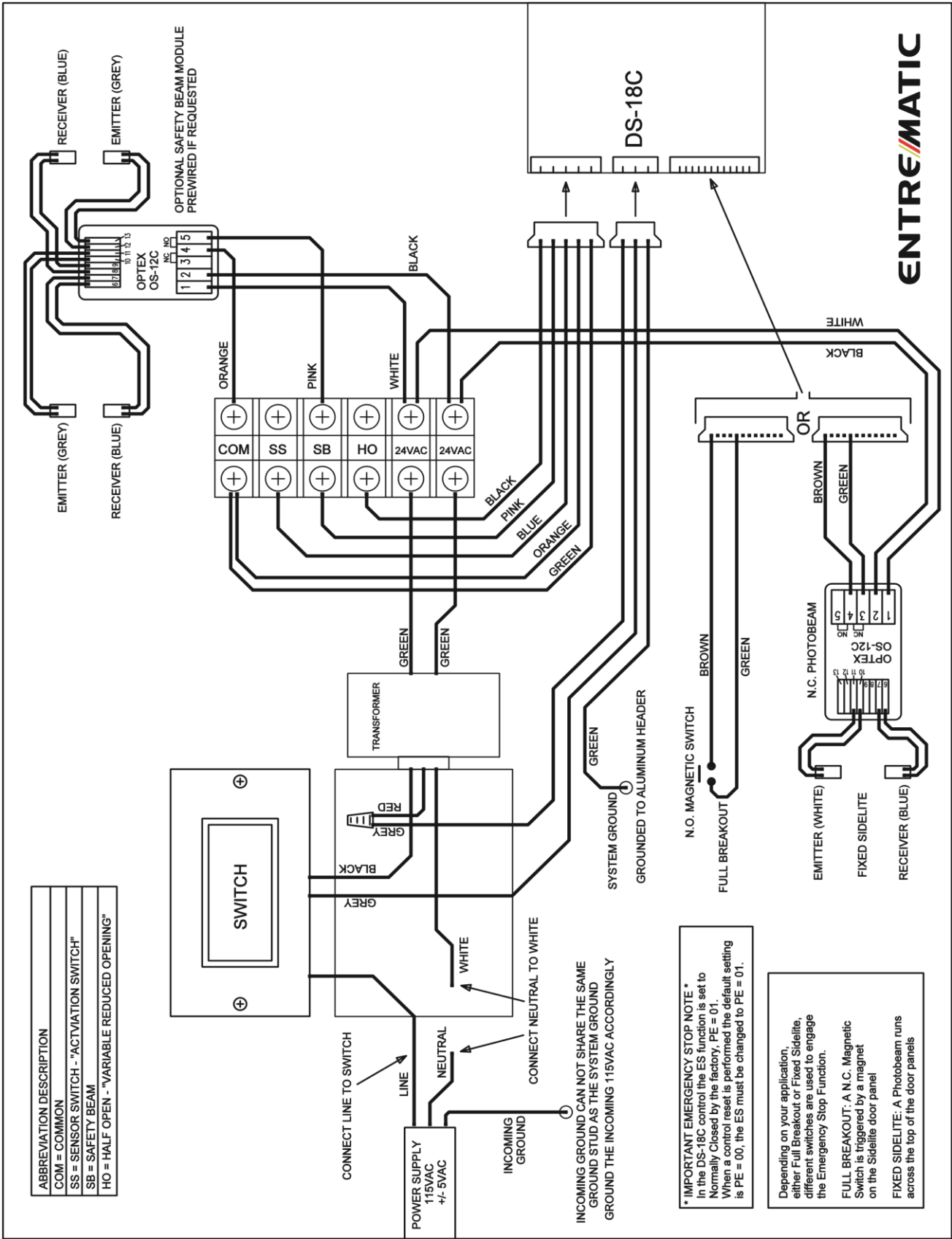

ABBREVIATION DESCRIPTION
COM = COMMON
SS = SENSOR SWITCH - "ACTIVATION SWITCH"
SB = SAFETY BEAM
HO = HALF OPEN - "VARIABLE REDUCED OPENING"

*** IMPORTANT EMERGENCY STOP NOTE ***
 In the DS-18C control the ES function is set to Normally Closed by the factory. PE = 01. When a control reset is performed the default setting is PE = 00, the ES must be changed to PE = 01.

Depending on your application, either Full Breakout or Fixed Sidelite, different switches are used to engage the Emergency Stop Function.
FULL BREAKOUT: A N.C. Magnetic Switch is triggered by a magnet on the Sidelite door panel.
FIXED SIDELITE: A Photobeam runs across the top of the door panels

ENTRE/MATIC

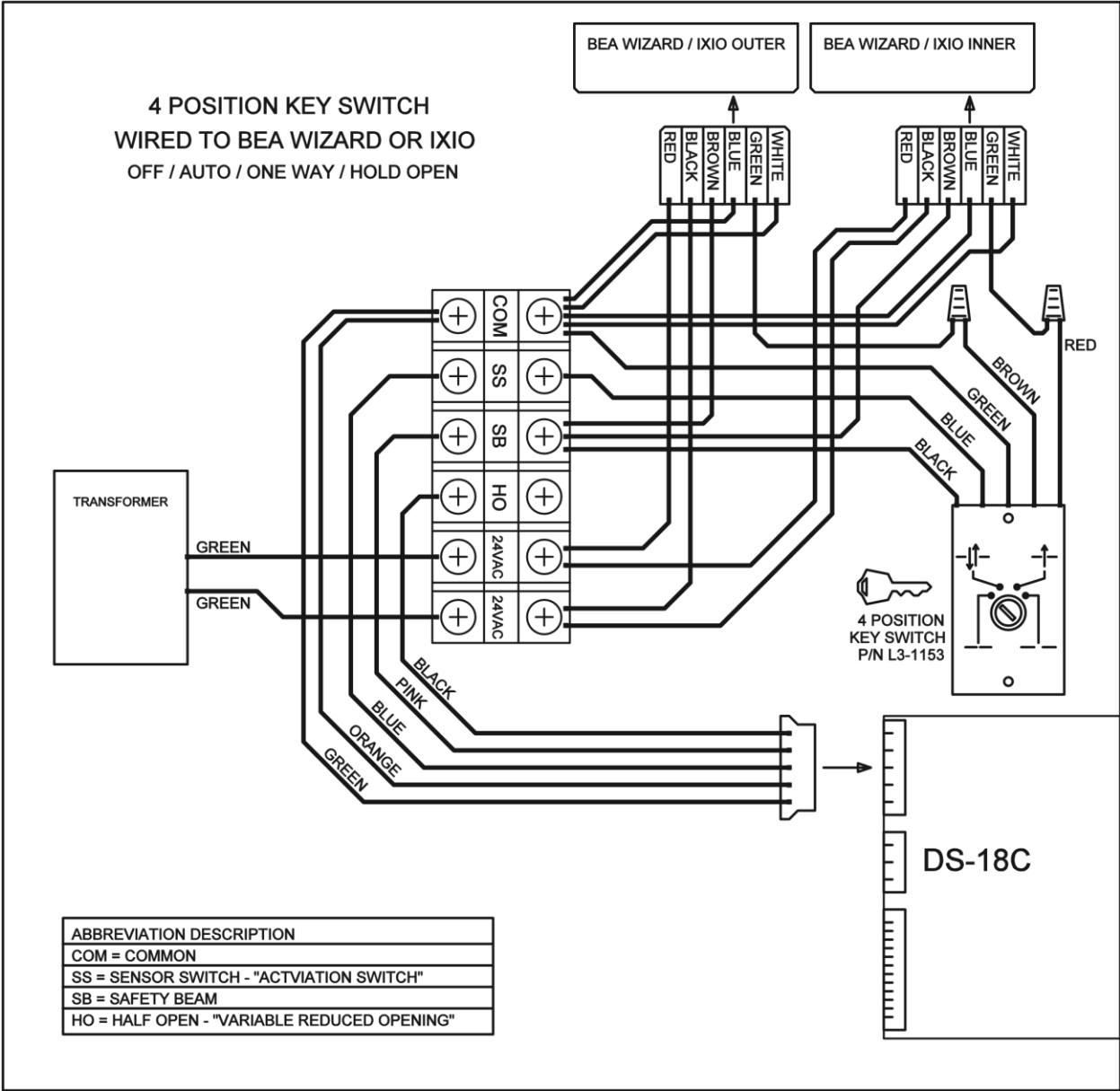

**4 POSITION KEY SWITCH
WIRED TO OPTEX OA203C
OFF / AUTO / ONE WAY / HOLD OPEN**

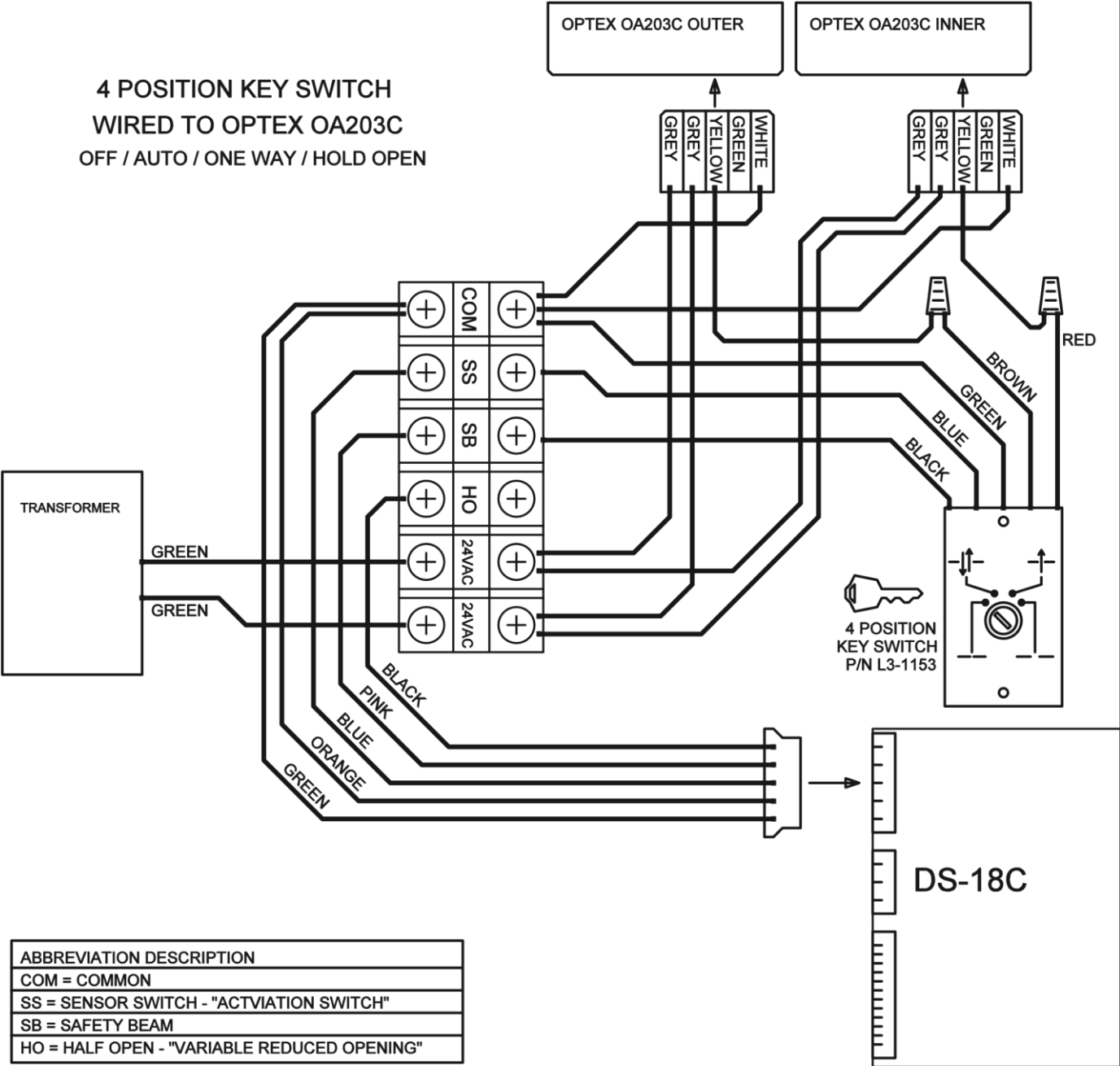

**4 POSITION ROTARY SWITCH
WIRED TO BEA WIZARD OR IXIO
OFF / AUTO / ONE WAY / HOLD OPEN**

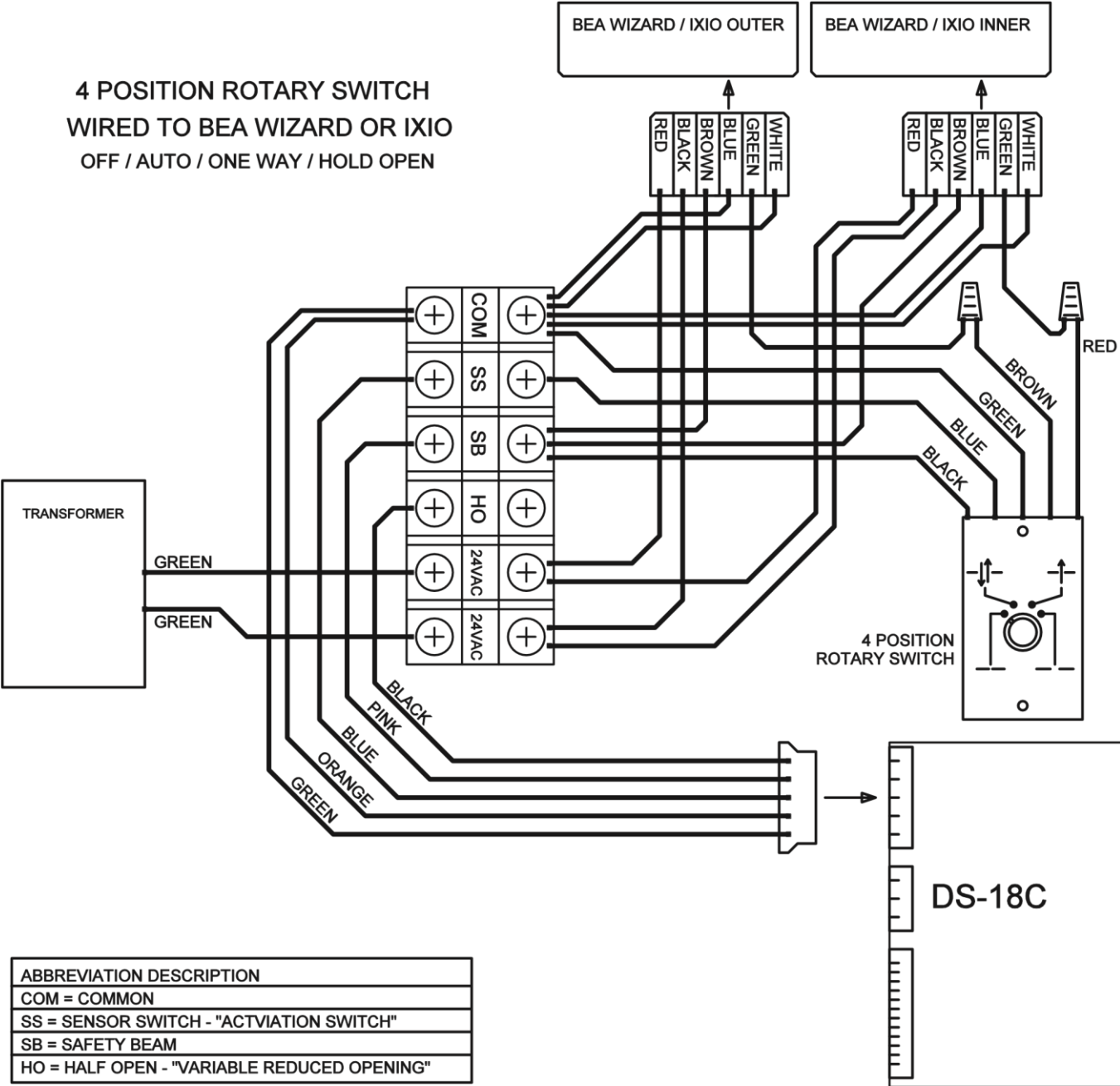

**4 POSITION ROTARY SWITCH
WIRED TO OPTEX OA203C
OFF / AUTO / ONE WAY / HOLD OPEN**

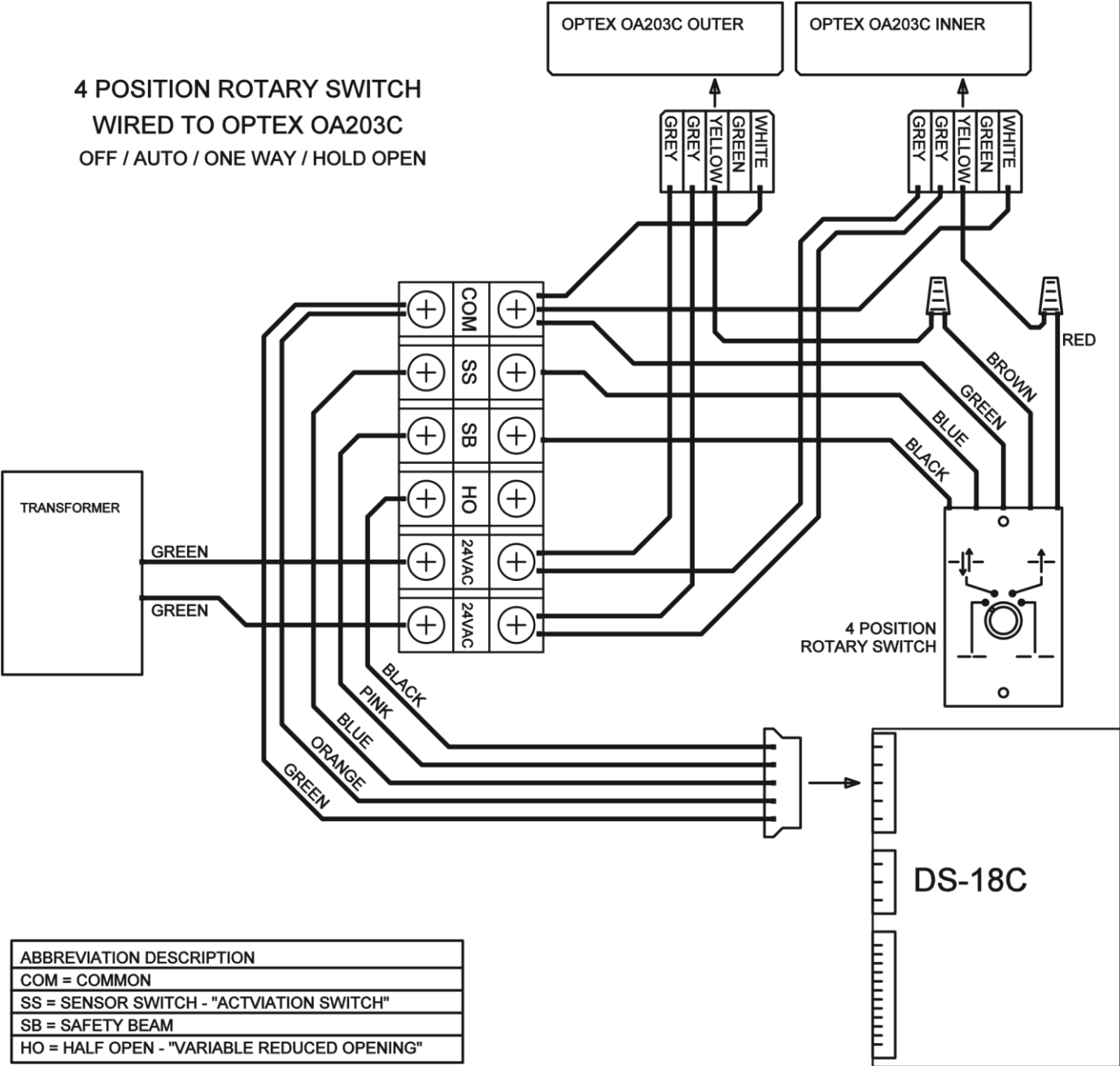

ABBREVIATION	DESCRIPTION
COM	COMMON
SS	SENSOR SWITCH - "ACTVIATION SWITCH"
SB	SAFETY BEAM
HO	HALF OPEN - "VARIABLE REDUCED OPENING"

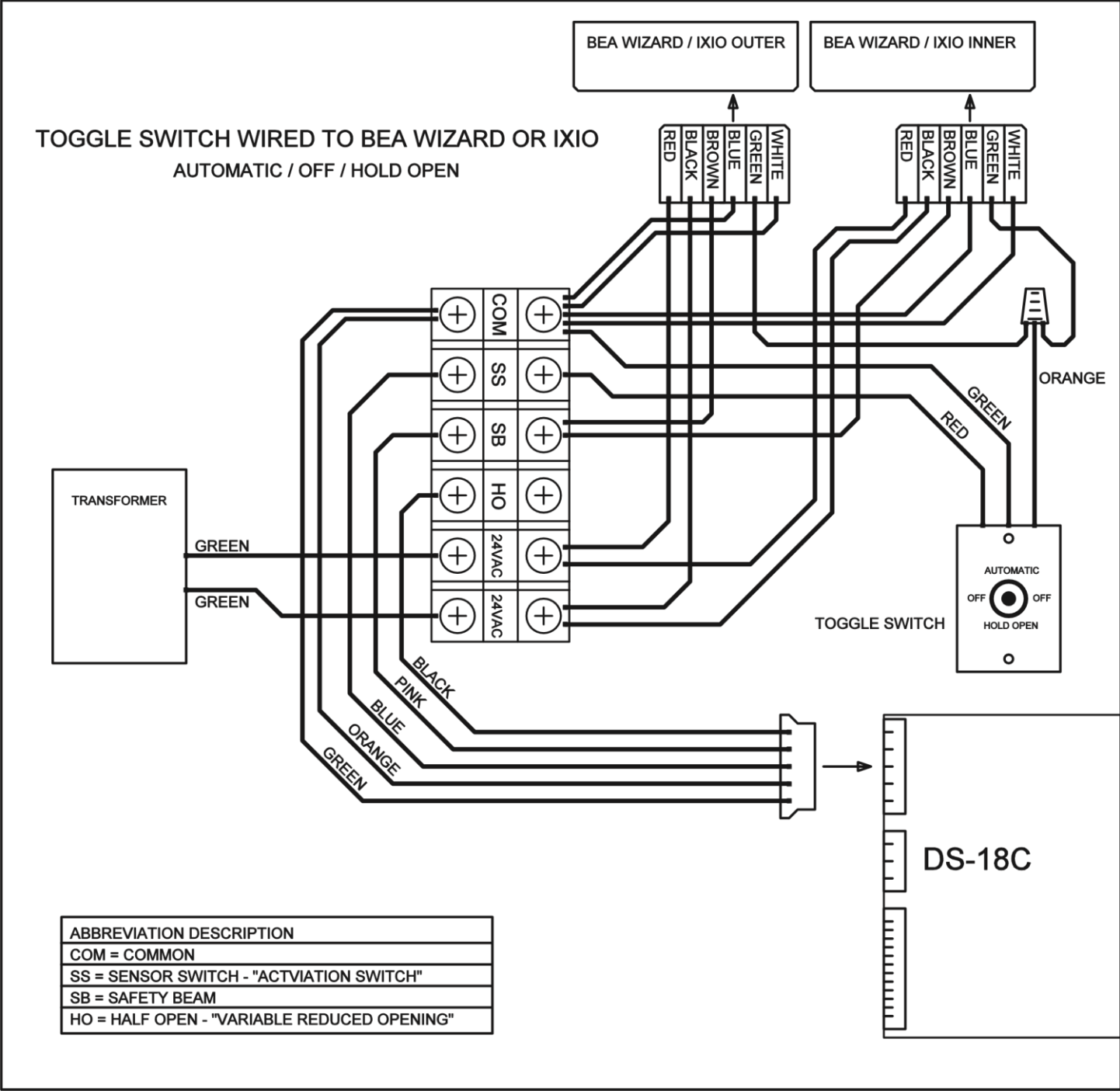

**TOGGLE SWITCH WIRED TO OPTEX OA203C
AUTOMATIC / OFF / HOLD OPEN**

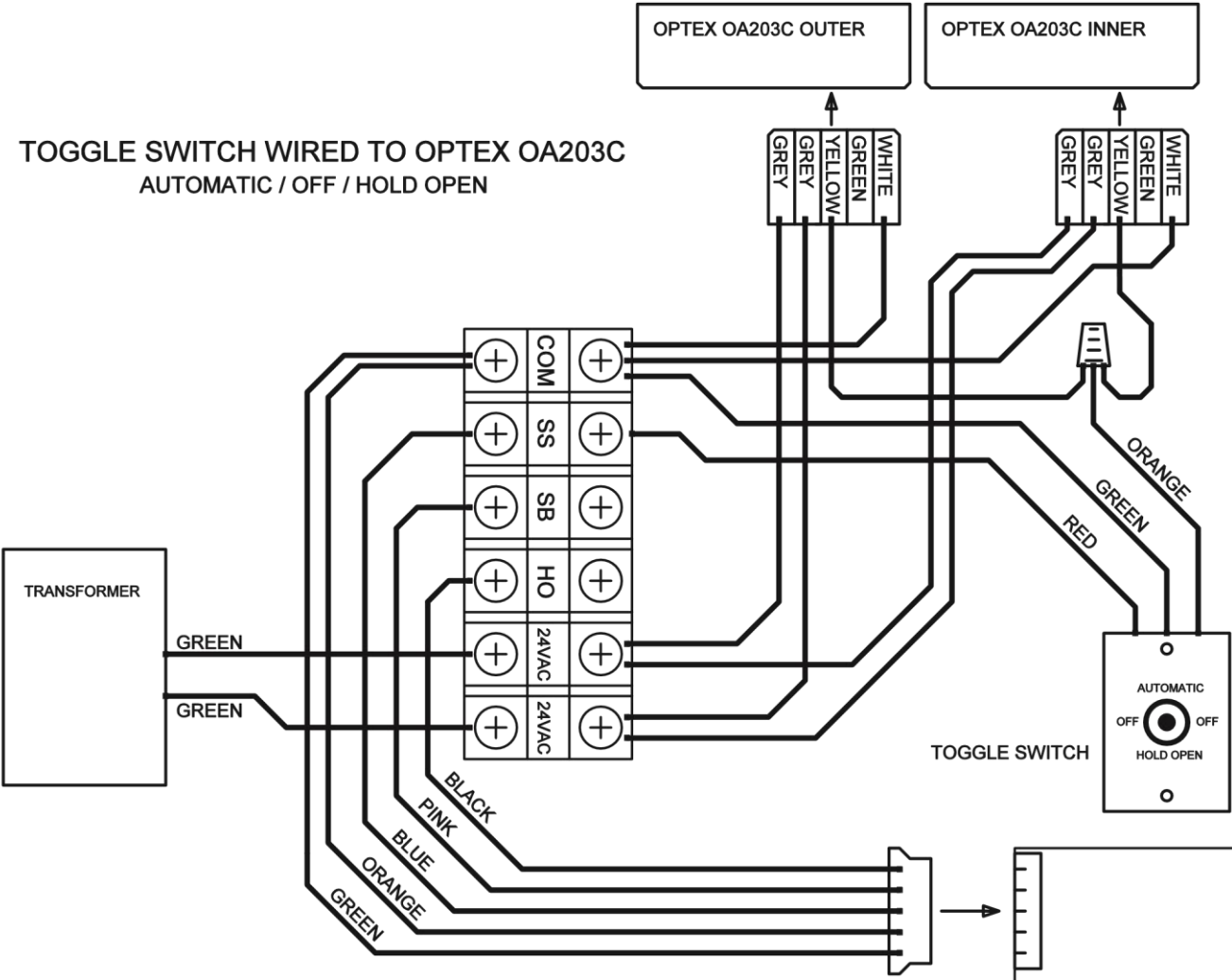

ABBREVIATION	DESCRIPTION
COM	COMMON
SS	SENSOR SWITCH - "ACTVIATION SWITCH"
SB	SAFETY BEAM
HO	HALF OPEN - "VARIABLE REDUCED OPENING"

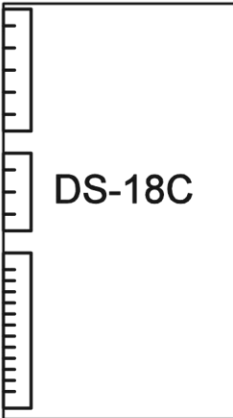

Set-up and Adjustment

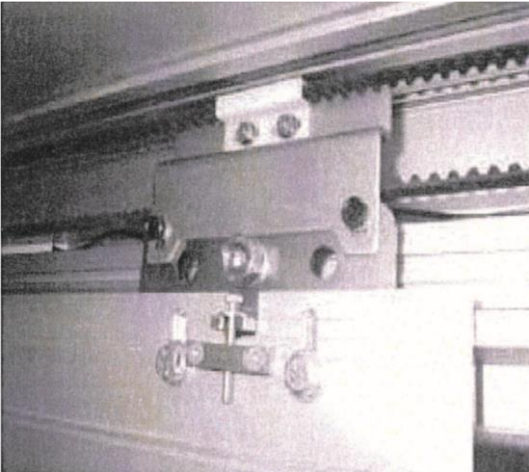

Figure 8

Once the glass has been installed the fine-tuning of the unit may begin. The Ditec OS series comes with factory settings and activation can be triggered by gently pressing the test button on the main controller.

DOOR HEIGHT

Door heights must be equal and parallel to carrier assembly by adjusting the carrier mount, as shown in *Figure 8*.

Loosen the two 5/16" bolts that are locking the carrier. To reposition the carrier height, turn the machine screw in the appropriate direction. When finished, re-tighten the locking bolts.

CENTERING THE DOORS

To adjust the doors, loosen the two locking screws on the belt clamp (the white nylon block shown in *Figure 10*). Center the doors in the opening, then re-lock the screws.

ADJUSTING THE BELT TENSION

To adjust the belt tension, loosen the lock nut. Next, turn the adjusting screw using a screwdriver, as shown in *Figure 9*. By turning the screwdriver, it will cause the wedge to pinch or relax its tension on the belt. Once the belt has been properly set, re-tighten the locking nut.

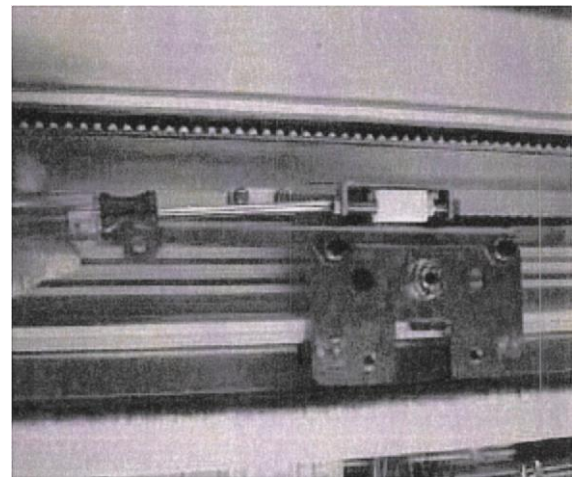
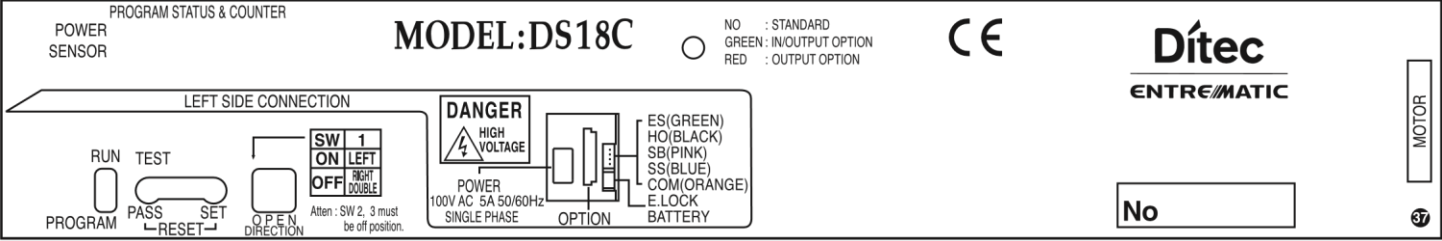

Figure 9

CONTROL BOX SET-UP

To enter the set-up mode, move the run/program switch from "run" to "program." All data is entered using the test/pass and set/check buttons. The test/pass button selects which value to modify. The set/check button is used to increase/decrease the selected value (i.e. speed, torque or braking forces).

All door operators are supplied with a set of factory default settings for all values, which can be tuned as needed for each installation. The setting codes list describes each available value and the available range. After the new value is entered, the current setting can be confirmed using the LED display (refer to the code list).



Drawing of Control Box

LED (LIGHT EMITTING DIODE) DISPLAY

The two-digit LED display can be used to display current settings, a cycle counter, and error codes. During set-up, it displays the selected setting and its value as you program the unit. When there is an error, it will show an error code, as well as an error history, such as the number of power failures or programming changes since the unit was manufactured. The LED can also show the number of cycles the unit has performed.

ADD-ON FUNCTIONS

The control box includes support for basic connections and functions, such as a sensor switch, safety beam, and half-open system.

A terminal strip is provided to facilitate the connection of all activation and safety devices and provides a 24 output for the powering of sensors. By jumping two terminals the HALF OPEN function is activated.

Additional functions can be added using an optional circuit board, such as a panic switch, emergency stop or OE & CE signals. Consult with the factory for details.

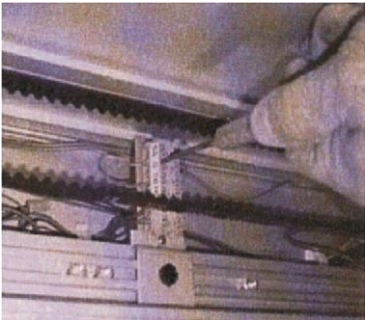

Figure 10

To insert wires into the terminal block, depress plastic tabs with a small screwdriver.

OPTIONAL EXTRAS

There are optional battery and locking systems available that can be installed to fit various safety and security needs.

SETTING OF OPENING DIRECTION

Door opening direction is set by dipswitch on the control box.

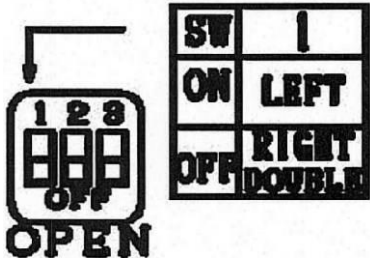

NOTE: Switches 2 and 3 are always OFF.

PROGRAMMING CODES AND VALUES

To begin programming of the DC One control panel, perform the following:

1. Press and hold the SET button and slide the RUN/PROGRAM switch to the PROGRAM position.
2. Release the SET button
3. LEDs should be displaying 01 if the control is still set at its default program.
4. Doors will stop moving and will be inoperable while in PROGRAM mode.
5. Press the TEST button repeatedly to toggle through the available codes/functions (all codes are listed below).
6. Upon reaching the desired code, stop pressing the TEST button.
7. To change the value for the code displayed, momentarily press the SET button. The code will begin flashing on the display.
8. Press the TEST button while the code LEDs are flashing to toggle through the value range for that particular code. Stop at desired value.
9. Momentarily press the SET button and the code will stop flashing. Program is now set for that code.
10. Repeat the above steps as many times as necessary to program all desired codes.
11. When all programming is complete, slide the RUN/PROGRAM switch back to the RUN position. The doors will begin to operate again. The control may go through another 6 cycle learn procedure for certain code changes affecting the stroke of the door.

BASIC CODE TABLE: SPEED/FORCE/TORQUE

Indications		Code Description	Factory Default	Reset Default	Remarks
LED 1	LED 2				
0	0~F	HOLD TIME	1		Hold time is 60 seconds max
1	0~F	HIGH SPEED OPENING	C		No limit applied to opening speed per A156.10. Speed should be set adequately for expected traffic conditions
2	0~F	LOW SPEED OPENING	8		Adjust so door does not bang open
3	0~9	OPEN BRAKING FORCE	4		Upon nearing full open, door should transition from high to low speed without abruptness
4	0~9	OPENING TORQUE	6		Default value should suffice for most applications
5	0~F	HIGH SPEED CLOSING	5		Doors should never close faster than 1 foot per second
6	0~F	LOW SPEED CLOSING	8		Closing check speed
7	0~9	CLOSE BRAKING FORCE	4		Upon nearing full closed, door should transition from high to low speed without abruptness
8	0~9	CLOSING TORQUE	6		Door should never exceed 30 lbs.
9	0~4	OPEN/CLOSE PRESSURE	1		Pressure applied when fully opened/ closed
A	0~9	HALF OPEN	3		See chart "HALF OPEN" on next page
B	0~9	TSTR	0		Teaching Stroke - automatic learning of total stroke
C	0~3	RESERVED SPECIAL	0		DO NOT USE

APPLICATION CODE TABLE

Indications		Code Description	LED 4 (Red)		Default	Remarks
LED 1	LED 2		LED On	LED Off		
<i>d</i>	0	BUZZER	ON	OFF	OFF	Buzzer provides audible warning error indications
<i>d</i>	1	CLOSING BRAKE POSITION	6"	2.75"	2.75"	Refers to closing check position
<i>d</i>	3	ELECTROMAGNETIC LOCK	YES	NO	NO	If electric carriage lock is installed, set to YES
<i>d</i>	4	BATTERY BACKUP	BC	BO	BO	Door will close (one shot) upon power loss
<i>d</i>	5	OPEN PRESSING	NO	YES	YES	Pressing at full open position
<i>d</i>	6	CLOSE PRESSING	YES/NO	YES	YES	Pressing at full closed position
<i>d</i>	7	HALF OPEN	FIX	AUTO	AUTO	If set to FIX, door will always open to reduced opening position
<i>d</i>	8	WARNING - BEFORE CLOSING	YES	NO	NO	Output signal to alarm on close
<i>d</i>	9	SB FUNCTION ON CLOSE END	YES	NO	NO	If set to YES, safety beam will remain active when door is closed
<i>d</i>	a	SELF CLOSING DEVICE	YES	NO	NO	Override for door with closing device (counterweight)
<i>d</i>	b	SAFETY FUNCTION	STOP	RETURN	RETURN	If set to STOP, door will stop upon a safety sensor input
<i>d</i>	c	RS FUNCTION DURING OPENING	YES	NO	NO	Ratchet relay function
<i>d</i>	d	INTERLOCK	RETURN	RETURN	RETURN	always open to reduced
<i>d</i>	e	NO/NC	RETURN	RETURN	RETURN	always open to reduced
<i>d</i>	f	AS FUNCTION	RETURN	RETURN	RETURN	always open to reduced

HALF OPEN ADJUSTMENT DESCRIPTION

Setting Code	0	1	2	3	4	5	6	7	8	9
Half Open %	12.5%	25%	37.5%	50%	62.5%	75%	87.5%	93%	95%	98%

Example: A door opening has an overall stroke of 80 inches. If control function **A** is set to a value of **3**, the result will be a 40 inch door opening.

TEACHING STROKE

The Teaching Stroke must be set to within 70% of the overall door stroke to prevent the door from opening the full distance in high speed. Set to 0 by default means a door will travel slower for one full cycle on initial learning stroke.

Setting Code	0 (default)	1	2	3	4	5	6	7	8	9
Teaching Stroke (cm)	ALL SLOW	12"	24"	36"	47"	59"	71"	83"	118"	157"

ERROR CODE TABLE

Four figures (*1, *2, *3, *4) shows total number of errors for respective error code. E8 and E9 are not errors; they are counters only.

Error Code	Error Description	LED 1	LED 2	LED Set 1		LED Set 2		Buzzer (If Enabled)
				LED 1	LED 2	LED 1	LED 2	
E 0	TSTR	E	0	0~9	0~9	0~9	0~9	
E 1	OPENING SAFETY	E	1	0~9	0~9	0~9	0~9	
E 2	CLOSING SAFETY	E	2	0~9	0~9	0~9	0~9	
E 3	INTERLOCK	E	3	0~9	0~9	0~9	0~9	
E 4	LOOSE BELT	E	4	0~9	0~9	0~9	0~9	
E 5	BROKEN BELT	E	5	0~9	0~9	0~9	0~9	
E 6	ELECTROMAGNETIC LOCK	E	6	0~9	0~9	0~9	0~9	
E 7	PS AND BATTERY	E	7	0~9	0~9	0~9	0~9	
E 8*	TIMES POWER ON	E	8	0~9	0~9	0~9	0~9	Counter only
E 9*	RESET TIMES	E	9	0~9	0~9	0~9	0~9	Counter only

Troubleshooting By Error Code

Error Code	Error Description	Probable Causes
E 0	Teaching Stroke error	Door weight exceeds max. allowed Door is locked Opening stroke is different than closing stroke
E 1	Opening error (lowered speed during opening)	Door weight exceeds max. allowed Open torque set to low Door obstructed upon opening
E 2	Closing error (lowered speed during closing)	Door weight exceeds max. allowed Closing torque set too low Door obstructed upon closing
E 3	Interlock error	Interlocked door is forced open manually Interlocked door has been moved
E 4	Door runs longer than programmed	Loose belt Door stop has been moved back
E 5	Non-stop motor rotation	Broken belt Running idle of motor pulley
E 6	Electromagnetic lock error	Code d3 improperly set Lock pin not mechanically functioning Lock cables damaged
E 7	Emergency movement Battery movement	No error present Indication of PS movement and battery movement only Code d4 set improperly

HELPFUL TROUBLESHOOTING HINTS

1. Before wiring any sensors into the DS18C board, it is a good idea to apply power and test the door to open and close when the TEST button is pressed.
2. The left side of a DS18C control has LEDs to indicate power and activation (sensors). If the red LED is illuminated, it means the control is being activated. Generally this means that the signal is being hold by a sensor that is in detection. This can be helpful for calls where the door is staying open. A quick look at the red LED will tell you if the reason for the hold open is from the activation being held.
3. If programming of the control is unsuccessful, it is easiest to restore the default values and then start over, rather than trying to correct any faulty programming.
4. When power is applied, the door powers open and stays open.
 - ✍ Motion or Presence sensor output is being held (closed circuit). If unsure which sensor, unplug one by one until fault is isolated. Correct as necessary.
 - ✍ Safety beam is blocked or is faulty. Correct as necessary.
 - ✍ Slide direction switch on the DS18C control is set to the wrong position. Slide the switch to the opposite position, and recycle the main power for the adjustment to take effect.
5. Door powers to close and stays closed.
 - ✍ Press the TEST button on the face of the DS18C control. Door should power open and then close. If it does not open, place the Slide Direction switch on the DS18C control to the opposite position and then recycle main power for the adjustment to take effect before testing again.
6. Door will not open or close.
 - ✍ As a first step, always check the DS18C digital display for Error Codes and proceed accordingly thereafter.
 - ✍ Breakout switch is not wired properly. If red light is on for the breakout function on I/O board is sending a breakout signal to the control, resulting in an inoperable door.
 - ✍ On/Off switch is not wired properly or is in the off position. The DS18C control will not operate without properly wired and functioning On/Off switch.

Warning Labels

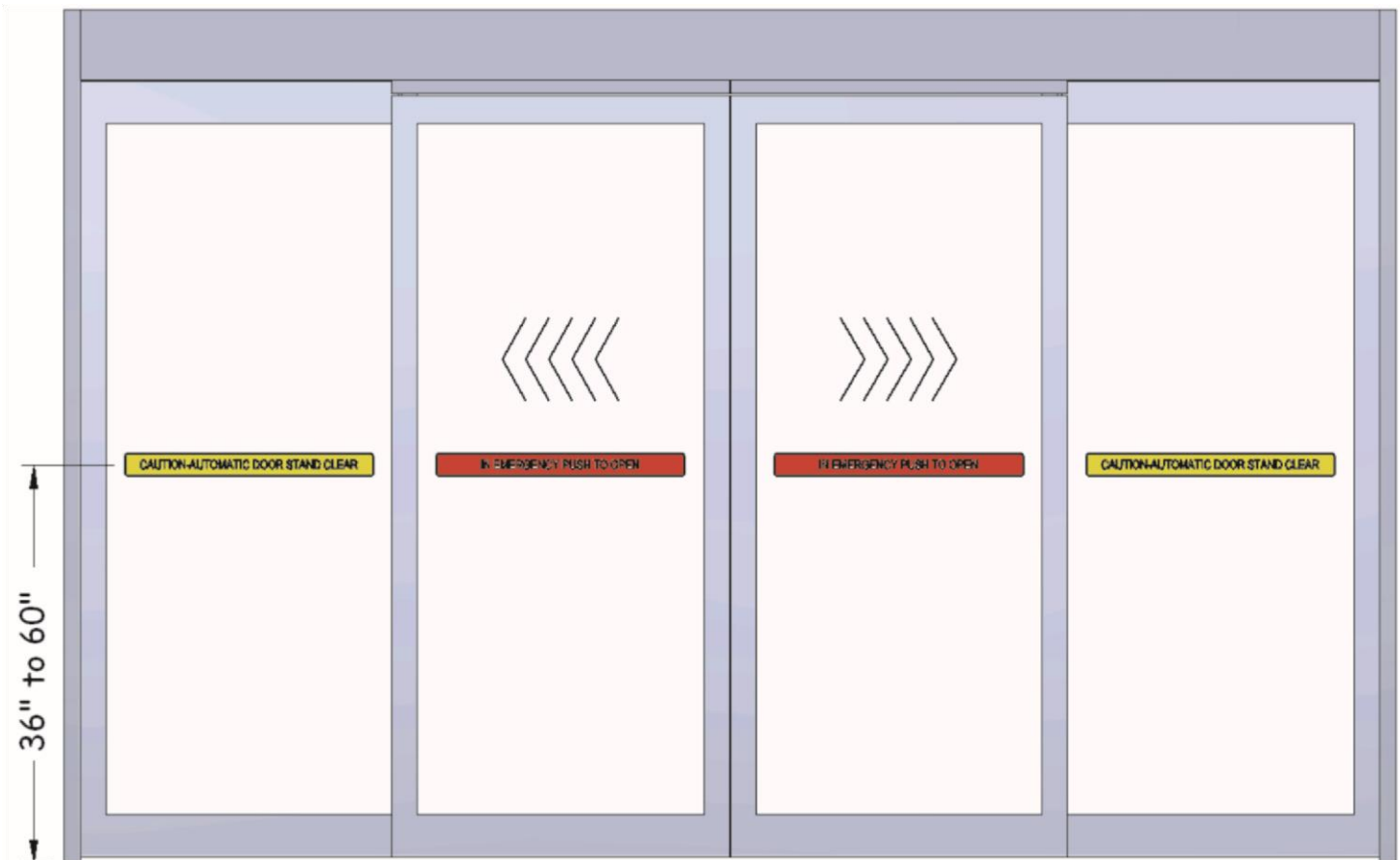

Replacement Parts

- Motor
- Control box
- Belt
- Pulley assembly
- Roller assembly
- Roller
- Door guide fork
- Door guide fixed side lite