

Series 4000

Surface Applied and Overhead Concealed Electric Swing Door Operator System

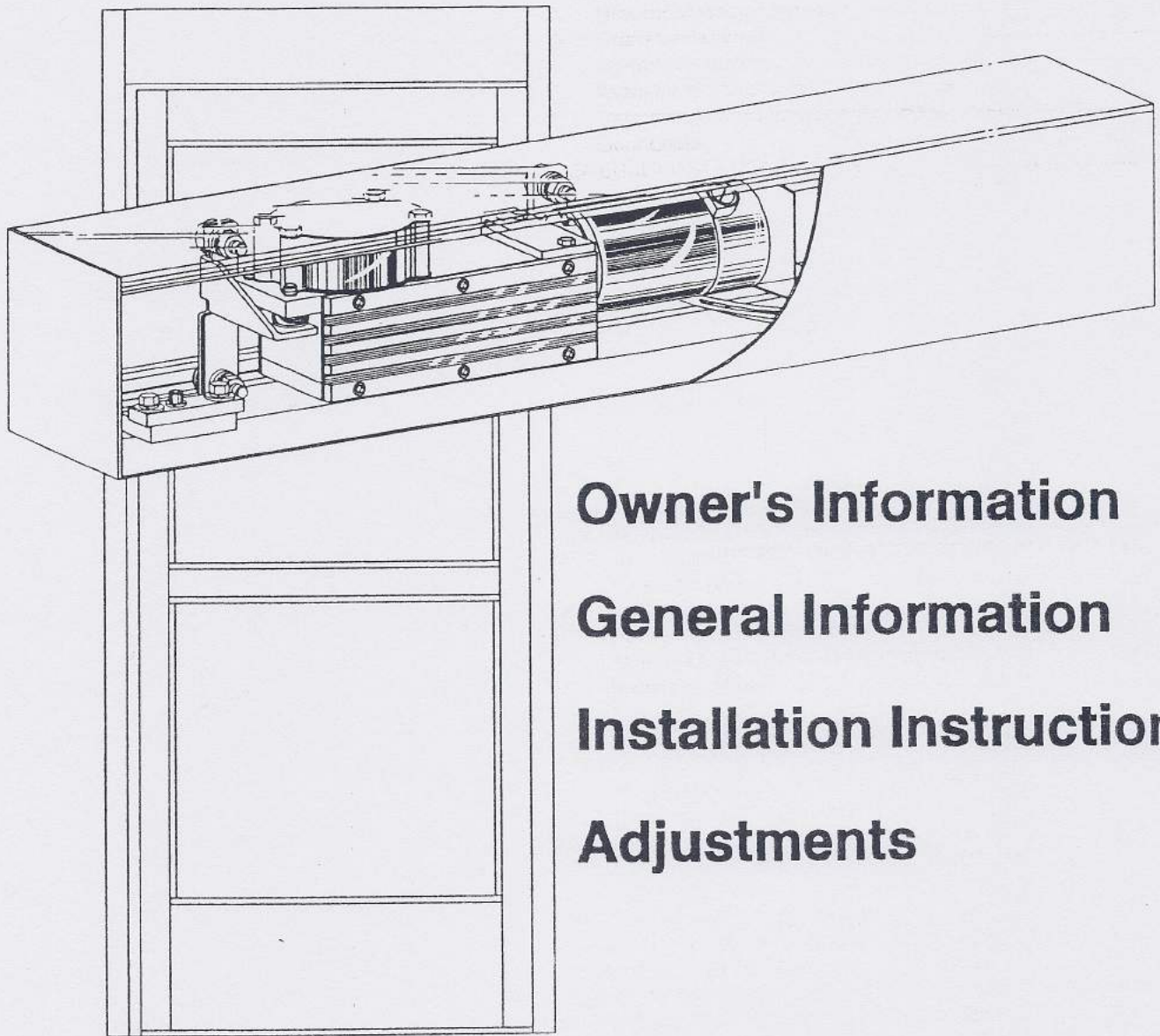

Owner's Information

General Information

Installation Instructions

Adjustments

TABLE OF CONTENTS

1.	OWNER'S INFORMATION.....	G400.3
2.	SERVICE AVAILABILITY.....	G400.3
3.	LIMITED WARRANTY.....	G400.3
4.	INSTRUCTIONS TO INSTALLER.....	G400.4
5.	TOOL LIST.....	G400.4
6.	INFORMATION PROVIDED BY DISTRIBUTOR TO OWNER.....	G400.4
7.	GENERAL INFORMATION / PRODUCT DESIGN.....	G400.5
	A. How the Operator Works.....	G400.5
	B. Operator Features.....	G400.5
	C. Operator Housings.....	G400.5
	D. Available Configurations / Series Types.....	G400.6
	E. Determining Door and Operator Hand (Swing Direction).....	G400.7
	F. Door Locks.....	G400.8
8.	GENERAL LIMITATIONS.....	G400.8
9.	GENERAL CONDITIONS.....	G400.8
10.	ELECTRICAL INFORMATION.....	G400.9
11.	INSTALLATION INSTRUCTIONS FOR SERIES 4100 - SURFACE APPLIED.....	G400.9
	A. Verify Hand of Operator.....	G400.9
	B. Verify Header Size.....	G400.9
	C. Mount Header to Frame.....	G400.10
	D. Mount Junction Box.....	G400.10
	E. Install Operator in Header.....	G400.11
	F. Install Control in Header.....	G400.11
	G. Install Adjustable Connecting Arm.....	G400.12
	H. Setting the Open Stop and Loading Operator Spring.....	G400.13
	I. Install Floor Stop.....	G400.14
	J. Check Door Operation.....	G400.14
	K. Alternate Step - Parallel Arm Installation.....	G400.14
12.	INSTALLATION INSTRUCTIONS FOR SERIES 4500 AND 4800 - OHC.....	G400.16
	A. Assemble Frame.....	G400.17
	B. Install Frame.....	G400.19
	C. Door Preparation and Installation of Pivots.....	G400.20
	D. Alternate Step - Direct Drive Installation and Door Preparation.....	G400.21
	E. Install Door Panel.....	G400.22
	F. Install Power Arm.....	G400.23
	G. Check Door Operation.....	G400.24
13.	ACTIVATING DEVICES AND SAFETY SYSTEMS.....	G400.24
	A. Motion Detectors.....	G400.25
	B. "Knowing Act" Activation Switches.....	G400.26
	C. Electric Mats.....	G400.27
	D. Guide Rails.....	G400.28
	E. Vista Safety System.....	G400.31
14.	WIRING AND MODULE INFORMATION.....	G400.40
15.	ADJUSTING THE OPERATOR FOR CODE COMPLIANCE.....	G400.43
16.	CHANGING OPERATOR HAND.....	G400.44
17.	APPLICATION OF SAFETY DECALS (Per ANSI Specifications).....	G400.44
18.	PARTS, ASSEMBLIES AND SUB-ASSEMBLIES.....	G400.45

TABLE OF FIGURES

1.	Header Types and Configurations.....	G400.6
2.	Determining Door Hand.....	G400.7
3.	Determining Operator Hand.....	G400.7
4.	Exploded View of Lock Assembly.....	G400.8
5.	Header Mounting - Side Load / Full Access.....	G400.9
6.	Header Mounting - Bottom Load.....	G400.10
7.	Operator Installation - Side Load and Full Access.....	G400.10
8.	Operator Installation - Bottom Load.....	G400.11
9.	Master Control Installation and Connections.....	G400.11
10.	Installation of Adjustable Connecting Arm and Mounting Foot.....	G400.12
11.	Standard Arm Connections - Plan Views.....	G400.12
12.	Standard Arm Assemblies.....	G400.12
13.	Two Methods of Setting the Open Stop and Loading Operator Spring.....	G400.14
14.	Parallel Arm Track Location.....	G400.15
15.	Parallel Arm Connections.....	G400.15
16.	Parallel Arm Assemblies.....	G400.16
17.	Side Load Frame Assembly.....	G400.17
18.	Bottom Load Frame Assembly.....	G400.17
19.	Frame Installation.....	G400.18
20.	Top Pivot and Door Prep.....	G400.19
21.	Bottom Pivot and Door Prep.....	G400.19
22.	Arm Installation and Door Prep - Direct Drive.....	G400.20
23.	Bottom Pivot and Door Prep - Direct Drive.....	G400.20
24.	Door Panel Installation - Side Load and Bottom Load.....	G400.21
25.	OHC Power Arm Installation.....	G400.22
26.	Plan - OHC Power Arm and Door Layout.....	G400.23
27.	C1801 Motion Detector and Zone Patterns.....	G400.24
28.	Activation Devices.....	G400.25
29.	Mat Requirements - Plan.....	G400.26
30.	Trim and Threshold Sections.....	G400.26
31.	Available Guide Rail Configurations.....	G400.27
32.	Guide Rail Layout and Size Requirements.....	G400.27
33.	Guide Rail Floor Prep. / Anchorage.....	G400.27
34.	Vista I Safety System Operation.....	G400.29
35.	Vista II Safety System Operation.....	G400.30
36.	Series 4000 Wiring Schematic for Vista I.....	G400.31
37.	Series 4000 Wiring Schematic for Vista II.....	G400.32
38.	Series 4000 Wiring Schematic for C4205 Swing Side Sensor Lockout Module.....	G400.34
39.	Series 4000 Wiring Schematic for C7215 Simultaneous Actuation Module.....	G400.35
40.	Description of C4150-1 Power Assist Close Module with Timing Sequences.....	G400.36
41.	Series 4000 Wiring Schematic for C4150-1 Power Assist Close Module.....	G400.37
42.	C7220-1 Strike Interface Module Information.....	G400.38
43.	Typical Schematic for C7220-1 Strike Interface Module.....	G400.39
44.	Series 4000 Wiring Schematic with C4160-1 Control.....	G400.41
45.	Series 4000 Operator with C4160-1 Control.....	G400.42
46.	Changing Operator Hand - Top Views.....	G400.43
47.	Safety Decal Placement on Series 4000 Swing Doors.....	G400.44
48.	Exploded View of Series 4000 Operator.....	G400.46
49.	Series 4000 Master Control Assembly, Lace Assemblies and Operator Mounting Bracket.....	G400.47
50.	Arm Assemblies and Sub-Assemblies.....	G400.48
51.	Series 4000 Top and Bottom Pivot Assemblies and Sub-Assemblies.....	G400.49

TABLE OF CHARTS

1.	Arm Information.....	G400.13
2.	Fastener Size and Prep.....	G400.18
3.	Standard Mat Sizes.....	G400.26
4.	Vista Safety Systems.....	G400.28
5.	Series 4000 Parts List.....	G400.45

SERIES 4000 ELECTRIC SWING DOOR OPERATOR SYSTEM

1. OWNER'S INFORMATION

We are pleased that you have chosen an Electric Swing Door Operator System from Horton Automatics. This door system will provide many years of safe automatic operation while conserving energy provided the unit is properly installed and maintained.

This Manual is Intended to Serve Two Purposes:

- A. To assist the Horton Distributor (Installer) in the installation / adjustment of a Swing Door.
- B. To serve as a guide for the Owner to become familiar with the operation and daily safety of his Swing Door Unit.

Regular inspections are required to keep each door in safe and proper working order. Please acquaint yourself with and follow all instructions in this manual.

Horton Automatics Swing Doors are offered with many options. Consequently, it is possible that this manual may not address all of the possibilities. This Manual, Wiring Diagrams, and Individual Shop Drawings should be kept in your files.

2. SERVICE AVAILABILITY

Horton Automatics' products are manufactured at the company's plant facilities in Corpus Christi, Texas and Telford, England. A network of authorized independent distributors— in the United States, Canada, Mexico, Asia and parts of Europe offer both installation and a maintenance program. In North America, for the local Horton Automatics distributor in your area, call 1-800-531-3111, or consult the Yellow Pages of your Telephone Book under "Door-Operating Devices." In Europe, call the Horton Plant in Telford, England at 011-44-952-670169.

3. LIMITED WARRANTY

Horton Automatics (the "Seller") warrants to the Buyer all products manufactured by the Seller to be free from defects in material or workmanship under normal use and service. The Seller's obligation under this warranty is limited to repairing or replacing, at its factory, any parts which are returned to Seller within twelve months, freight charges prepaid, and which upon examination prove to be defective. Said warranty shall not apply to products which have been installed, altered, or repaired by any persons not expressly authorized by Seller in writing to do so, or which have been subjected to misuse, negligence or accident.

There is no warranty of merchantability of fitness for any particular purpose or any other warranty express or implied except as specifically stated herein.

Seller shall in no event be liable for special or consequential damages of Buyer or claims of any third party against Buyer.

Generally, the installing distributor provides a one-year warranty covering the labor and transportation charges for defective parts replacement. Please ask your installing distributor for any warranty concerning these items. Any such warranty is only from and on behalf of such distributor, as Seller does not authorize any other party to provide any other warranty on behalf of Seller.

4. INSTRUCTIONS TO INSTALLER

Horton Automatics is pleased that our Electric Swing Door System has been chosen for this installation. We have carefully designed, tested, and built this door system for high quality and years of service. This door must now be installed and adjusted properly to ensure a high standard of operation and safe use.

To install and adjust the door for proper and safe operation, the installer must carefully read this Instruction Manual before proceeding, then follow the instructions exactly.

This door is to be installed only by trained and knowledgeable installers. One should be experienced in the installation of automatic entrances. You should know all your local code requirements, and be familiar with the requirements of ANSI A156.10 Standards for Power Operated Doors.

After Installation the door must be adjusted to conform with Horton's recommendations and all code requirements. Be sure to carefully study these requirements in these instructions.

After installation and adjustment, the installer's final responsibility is to properly instruct the owner in the safe use of the door. You must present the owner with this Installation Instruction Manual. **You must also provide the Owner's Manual M310 and carefully explain how to perform the Daily Safety Check Test it contains.** Each step of the installation and adjustment instructions are important for proper and safe use of the door. If you have any questions about any item contained in these instructions, call Horton's Customer Service Department for assistance.

5. TOOL LIST

For a fast and complete installation the following tools will be required :

- | | |
|---|--|
| <input type="checkbox"/> Pocket knife | <input type="checkbox"/> Screwdrivers: Phillips - #2 and #3, Straight - small and medium |
| <input type="checkbox"/> Hammer | <input type="checkbox"/> Open end wrenches: 7/16", 1/2", 9/16", 3/4" |
| <input type="checkbox"/> Tape Measure | <input type="checkbox"/> Socket and ratchet: 3/8" drive, 3/8", 1/2" |
| <input type="checkbox"/> Chalk Line | <input type="checkbox"/> 9/16" socket set with universal adapter |
| <input type="checkbox"/> Hacksaw | <input type="checkbox"/> Allen wrench set |
| <input type="checkbox"/> Wire cutter | <input type="checkbox"/> Electrical extension cord |
| <input type="checkbox"/> Electrical tape | <input type="checkbox"/> 3/8" drive torque wrench |
| <input type="checkbox"/> 4' level | <input type="checkbox"/> Extension for 3/8" drive set - 6" |
| <input type="checkbox"/> Flat file (coarse) | <input type="checkbox"/> Standard drill bits #19, 21, 31, 1/4", F, and countersink #18 |
| <input type="checkbox"/> Ladder - 4' or 6' | <input type="checkbox"/> 1/4" electric drill |
| <input type="checkbox"/> Channel lock pliers | <input type="checkbox"/> 5/16" and 1/4" Masonry bits |
| <input type="checkbox"/> Volt / Ohm Meter | <input type="checkbox"/> Impact drill hammer |
| <input type="checkbox"/> | <input type="checkbox"/> |

6. INFORMATION PROVIDED BY DISTRIBUTOR TO OWNER

- Location of on / off switches and power circuits.
- Locations and use of Circuit Breakers if power operated.
- Necessary warnings not covered in these general instructions.
- AAADM compliance certificate signed by an AAADM certified automatic door inspector.
- Local phone number to call regarding problems or request for service. If a potentially hazardous situation is suspected, lock the doors until a professional inspection is made and the problem is corrected.

Additional Information Provided to The Owner:

Date Equipment Shipped From Horton Automatics: _____

Date Equipment Placed Into Service: _____

Horton Automatics Invoice Number For Warranty Reference: _____

Equipment Type: _____

Accessories Included: _____

7. GENERAL INFORMATION / PRODUCT DESCRIPTION

Horton Automatics Series 4000 Swing Door Operator automates swing doors used by pedestrians or vehicles in commercial establishments. It is a heavy duty operator suitable for use in supermarkets, department stores, post offices, hospitals, airports and other heavy traffic locations.

A. How the operator works

When the C4160-1 master control is energized the door opens in open speed. Opening speed should not be faster than 1.5 seconds to open check.

When the door is approximately 15° from full-open, the open check cam/switch changes the master control to the check speed and the door slows down as it continues to the full open position. An internal stop in the operator stops the door at full-open and holds it open by using reduced motor voltage. When the activating and safety signal are removed, the door closes after an adjustable time delay expires.

The door closes by spring force, but the closing speed is controlled by the motor that acts as an electric brake. The closing speed is variable and can be adjusted. ANSI has requirements to set the Maximum closing speed and force.

Note: In special situations, low voltage applied to the motor will assist the spring to close (Power Assist Close).

When the door reaches the last 10° of closing, the close check cam/switch changes the speed control to a fixed setting that slows the door. The final 10° of closing cannot occur in less than 1.5 seconds.

B. Operator Features

- Self-contained electromechanical operator requiring 120 VAC power.
- Helical reduction gears - allowance for motor to run at rated RPM without strain or overheating.
- Fully adjustable open and close speeds.
- Manual operation with power on or off.
- Bottom access for service-allows operator to be installed in ceiling. (*Optional Header*)
- Field replaceable heavy duty Quadra-coil closing spring.
- Isolated pivot - even on an OHC application the door does not have to be removed to service the operator. (*Direct Drive is Optional*)
- Shock mounted.
- 1/8 HP DC permanent magnet motor, 1800 RPM.
- Soft start to cushion operation.
- Modular construction.
- Low current draw in the open position makes a hold open option available.
- Emergency breakout position is held open with spring tension.
- Infinite speed adjustments.
- Adjustable time-delay 1-28 seconds.
- Meets U.L. requirements and is listed.
- Bears CSA File #LR 53587-2.

C. Operator Housings

Composition and Materials: The operator is supplied with an aluminum cover constructed of 6063T5 or KE45 alloy with a minimum thickness of 1/8" (3). Three sizes are available - 4 1/2"x 6" (114 x 152), 6"x 6" (152 x 152) or 6 3/16"x 6 3/16" (157 x 157).

Finishes and Color: Available in standard finishes of 204-R1 clear anodized aluminum or dark Bronze 313-R1. Other anodized aluminum colors or paint processes are available if specified.

GENERAL INFORMATION / PRODUCT DESCRIPTION CONT.

D. Available Configurations / Series Types

Series 4100: The operator is **surface applied** to the door frame header and includes connecting arms. Can be used on doors with butt hinges, offset or center pivots. Doors with emergency breakout feature must be center pivoted.

Series 4500: A complete package that includes **operator in overhead concealed mounting (OHC)**, door(s), threshold, finger guard and frame. Standard package is supplied with 1-3/4" x 4" (44 x 102) frame. Other frame dimensions are available. Package available to include transom.

Series 4800: The operator in **overhead concealed mounting (OHC)**. The operator is easily installed to the selected door and frame supplied by another contractor. The door top and bottom pivot, concealed track, and threshold are included. Pivot point allows for finger guard application. The door and frame are not included by Horton Automatics.

Series 4000 LE: The operator is surface applied to the door frame header and includes connecting arms. Can be used on doors with butt hinges, offset or center pivots. This operator is push-button or Push-N-Go™ activated. Push-N-Go activates the operator when anyone simply pushes on the door. The door opens at the set opening speed, then closes. The operator has adjustable slow opening and slow closing speeds, adjustable time-delay, Time Out™ a safety feature that turns the operator off if the door is stopped during opening cycle then returns the door to closed and *Soft Touch™* a feature that reopens the door if the door is stopped during the closing cycle.

Fig. 1 - Header Types and Configurations

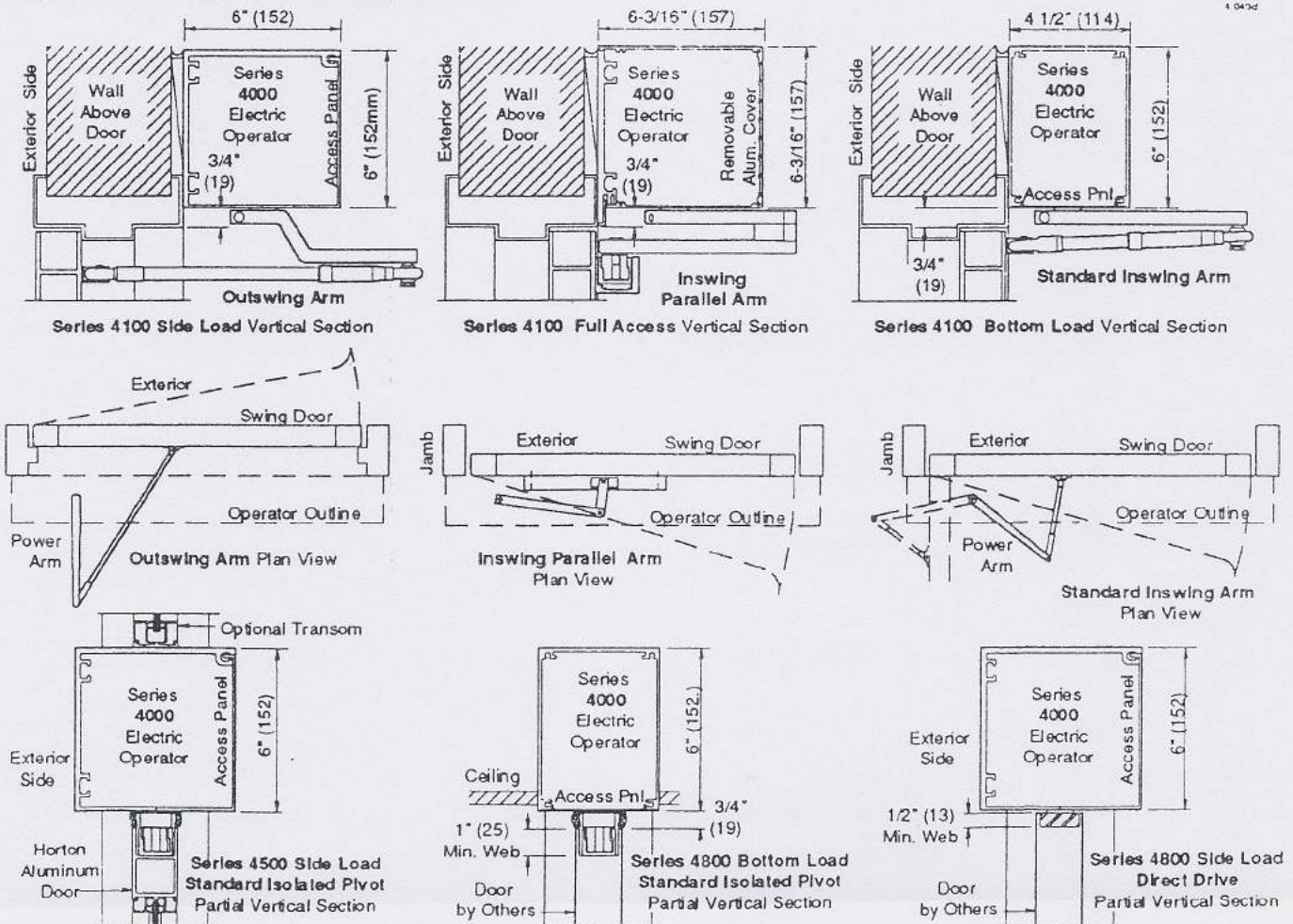

GENERAL INFORMATION / PRODUCT DESCRIPTION CONT.

E. Determining Door and Operator Hand (Swing Direction)

The Series 4000 is a universal operator with a single-acting spring that always returns the door to the closed position, unless it is in the breakout position. The operator can be adapted to either hand or swing direction. Simply prepare the operator for the hand required by interchanging the check switch wiring harness and reversing the spring, then interchange motor wires so that the operator powers open in the desired direction.

The floor plan in Figure 2 shows the door hand for ordering purposes only. This hand tells the factory what pivot location to make the cover so the face plate will always be to the interior of the building.

Fig. 2 - Determining Door Hand

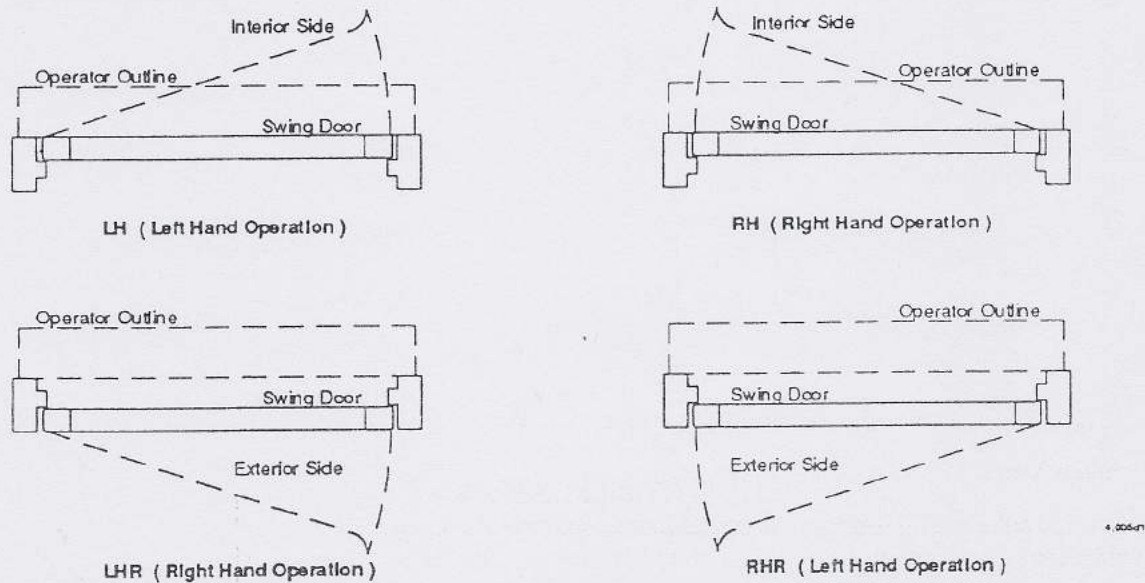
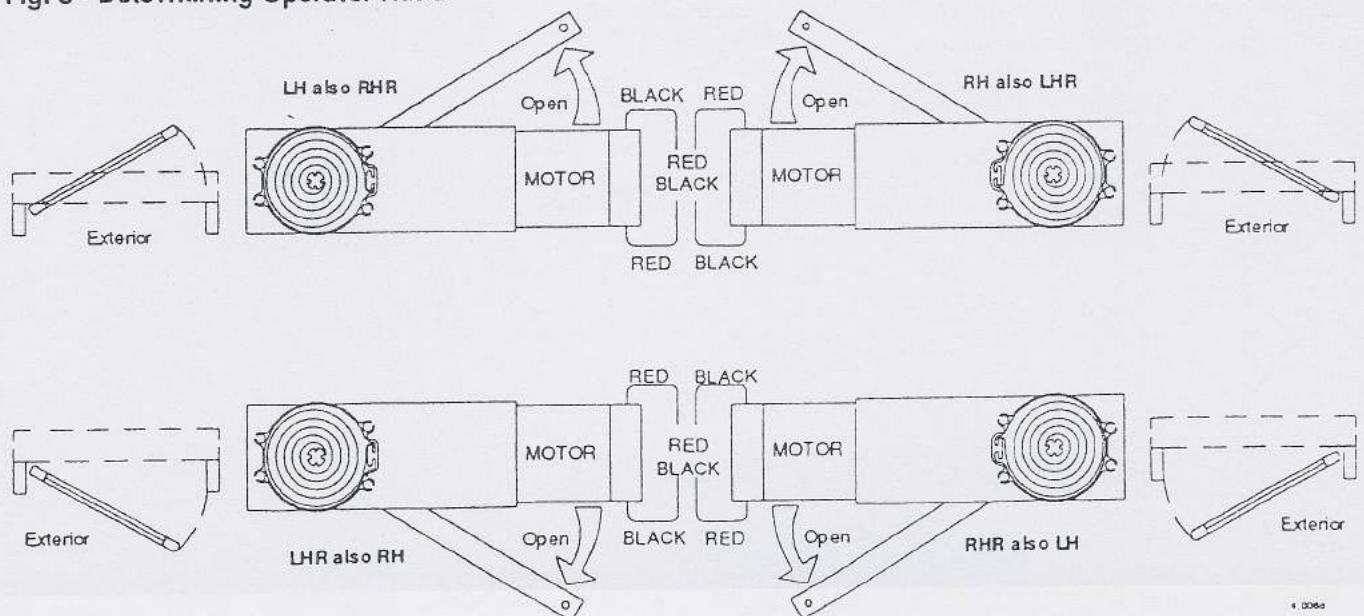

Fig. 3 - Determining Operator Hand



GENERAL INFORMATION / PRODUCT DESCRIPTION CONT.

F. Door Locks

Swing door units are equipped with ©Adams Rite #MS1850 lock (Horton No: C454), C455 cylinder, C463-1 thumbturn, C459 keeper, and C883 dropbolt. Single unit doors lock into the jamb which are predrilled with a keeper prep. UL requires that the inside cylinder lock be equipped with a thumbturn. If the thumbturn is removed, the UL listing will be voided. Also, if the cylinder is replaced, the new version must be 1-5/32" diameter and should have ©Adams Rite compatible maximum security cam (Fig. 4, This Page).

Fig. 4 - Exploded View of Lock Assembly

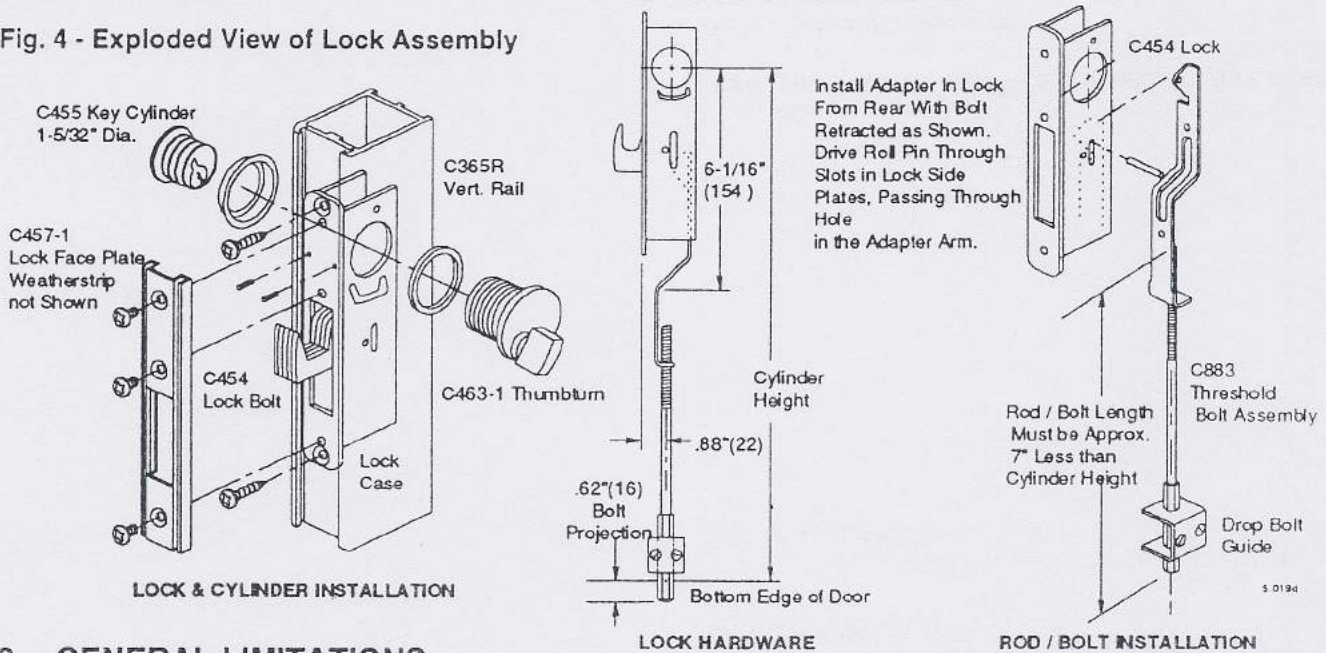

8. GENERAL LIMITATIONS

- Automatic Swing Doors are not the best choice for use in two-way traffic or in areas that have strong wind conditions. The Automatic Sliding or Bifolding Door is better suited for those conditions.
- ANSI A156.10 Standard requires two guide rails on swing side of power operated swing doors used by the general public
- Finger guards are required to protect against finger pinching at hinge.
- If the operator is mounted on an aluminum/glass door, the glass and glazing must comply with ANSI Z97.1 Standard. Should the glass be changed for whatever reason, those changes must comply with the Safety Glazing Law

Note: For further requirements see Item No. 16 "Adjusting the Operator for Code Compliance", this manual.

9. GENERAL CONDITIONS

Upon receipt of operator package, installer should verify that all operator assembly parts listed on the packing slip are included in the package.

Verify with the General Contractor the exact location of the swing door unit. The rough door opening must be plumb and level. A straight edge should be positioned in the floor sill in the door frame opening to assure it is level and square with the frame jambs. The door unit header works well as a straight edge. To assure a proper installation of the swing door, it is critical that the entire door opening sill and floor area below swing of door is level and smooth.

When the operator is to be installed on a door-by-others or an existing door, it is important that the operation of the door be free and unrestricted. Hinges must be good quality and be in good working order. The area where the operator is to be installed must be sturdy and reinforced.

10. ELECTRICAL INFORMATION

A 120 VAC, 60 Hz, 15 Amp dedicated circuit should be routed to each swing door header (maximum two operators).

A 1.25 Amp magnetic circuit breaker assembly (C4155) is installed in the header for each operator. This circuit breaker is always accessible from a clearance hole located on the underside of the header. In the event of an electrical overload, the circuit breaker will automatically release and turn the operator off. The toggle may be reset after the problem is corrected.

Verify the exact location of any actuation or safety systems mounted to the building structure requiring an additional circuit and or conduit installation. **All wiring must be in accordance with the National Electrical Code (U.S. installations) and with the Canadian Electrical Code (Canadian installations) and any local authority having jurisdiction.** Europe provides 220 VAC and requires either a C4260 Master Control or step down transformer.

Note: The actual amperage drawn per operator is less than 2 amps (average).

11. INSTALLATION INSTRUCTIONS FOR SERIES 4100 - SURFACE APPLIED

Instructions for installing Side Load, Full Access and Bottom Load covers are very similar. The basics of all three installations are included on the following pages. The side load cover is depicted in most of the drawings. *Note: Header is normally prepped at factory and the operator is shipped in the cover.*

A. Verify Hand of Operator

Refer to page G400.7. See page G400.43 if changing the operator hand is necessary.

B. Verify Header Size

The header should measure 3" longer than the width of the door opening (1 1/2" overlap each side). With endcaps in place and for Side Load and Full Access covers, the total header will be 3 1/4" (1/8" endcaps) longer than the opening. With endcaps in place for Bottom Load cover the total header will be 3 1/2" longer (1/4" endcaps) than the opening.

C. Mount Header to Frame

1. Position header so that the bottom is 3/4" above the top of the door as shown in Fig. 5 below and Fig. 6 on next page (See also Fig. 1, page G400.6)
2. Secure header to frame as shown.

Fig. 5 - Header Mounting - Side Load / Full Access

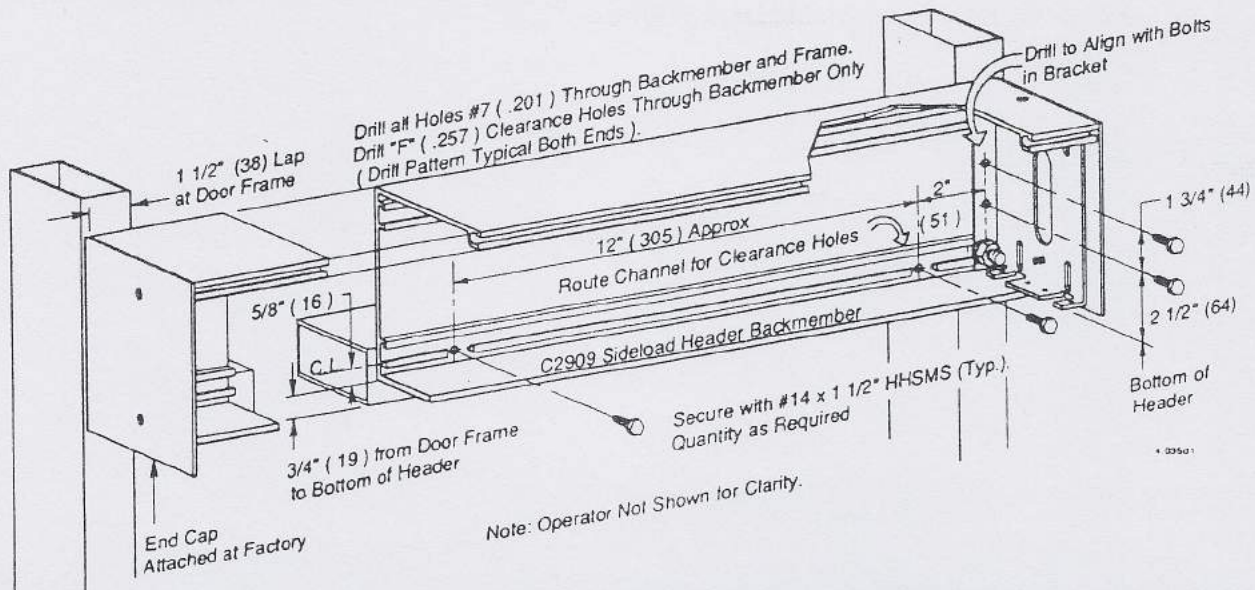

INSTALLATION INSTRUCTIONS FOR SERIES 4100 - SURFACE APPLIED -
PART (C) CONT.

Fig. 6 - Header Mounting - Bottom Load

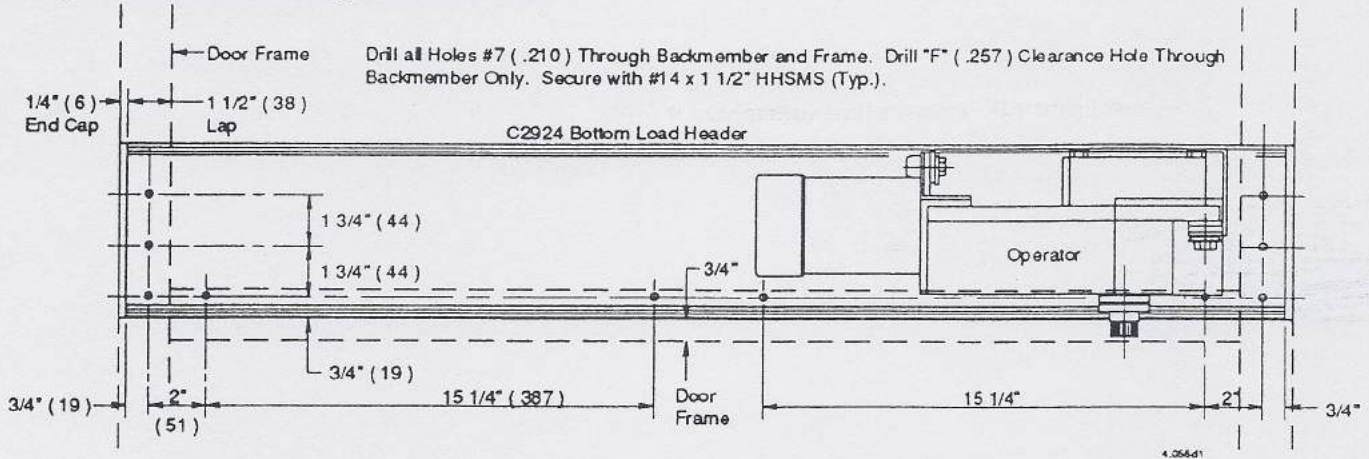

D. Mount Junction Box

1. Attach the junction box to the inside of the header where it will not interfere with control or operator installation.
2. Provide 120 VAC, 10 Amp dedicated service to the junction box in accordance with the National Electrical Code.

E. Install Operator In Header

As noted earlier, the operator is typically shipped in the header. The following steps are required only if the operator was purchased separately from the header or if the operator was previously removed from the header.

Side Load and Full Access

1. Insert C4146 square headed bolts in bolt channel slots (two upper bolts and two lower bolts). Position as shown in Fig. 7, below, from pivot end of header backmember.
2. Position operator so that the holes in the C4141 mounting bracket align with the C4146 bolts
Note: this should place the center-line of the output shaft 5 1/2" from the pivot end of the header backmember.
3. Secure operator with bracket onto bolts as shown.

Fig. 7 - Operator Installation - Side Load and Full Access

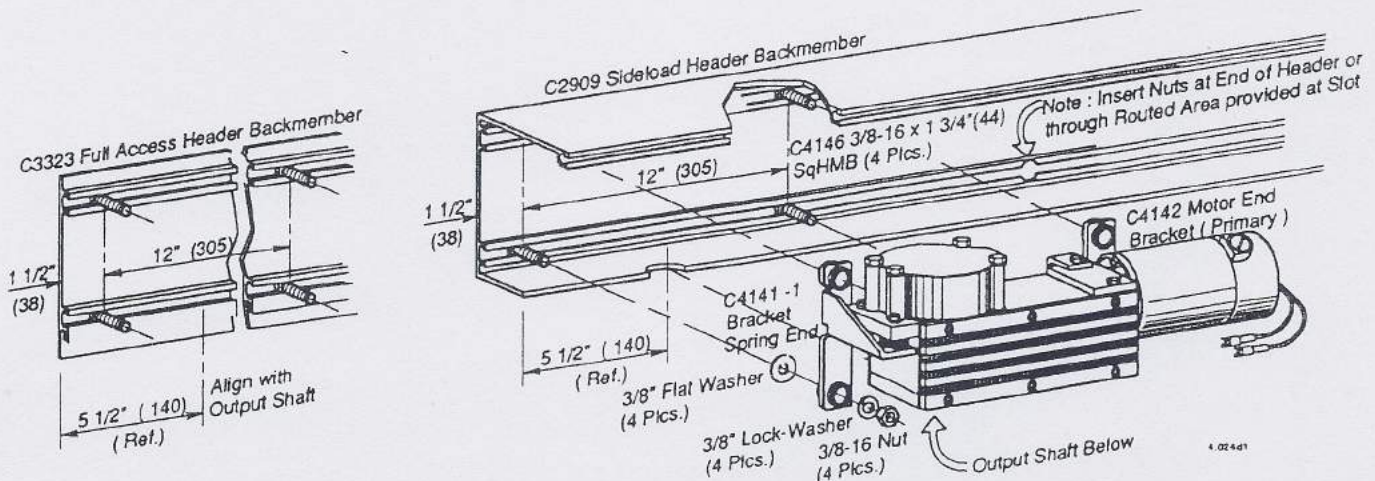

INSTALLATION INSTRUCTIONS FOR SERIES 4100 - SURFACE APPLIED - PART (E) CONT.

Bottom Load

1. Hold operator at a vertical angle. Insert through the notched groove at the top of the header.
2. Straighten operator to horizontal while sliding it into place, then secure as shown in Fig. 8.

Fig. 8 - Operator Installation - Bottom Load

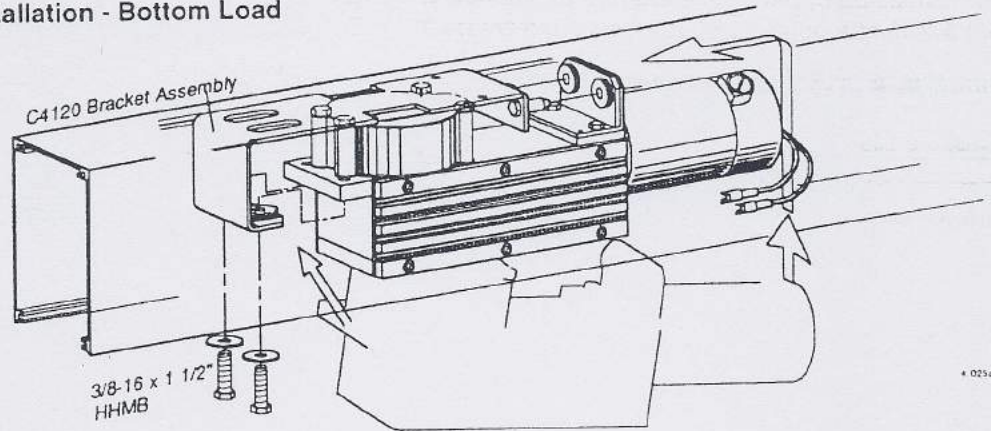

F. Install Control in Header

1. Screw the control to its two mounting brackets and connect the 10 pin connector into control.
2. Raise the control assembly into place and snap the mounting brackets into the grooves located on the back face inside the header (Fig. 9). On Bottom Load the grooves are along the top.
3. Connect the wiring harness to both the operator switches and the motor.
Switch Wires: Blue/Gray to latch check.
Yel/Org/Brn to back check.
Motor Wires: RH or LHR = Red to Red, Blk to Blk.
LH or RHR = Red to Blk, Red to Blk.
4. Mount the circuit breaker in the 1/2" hole located in the bottom section of the header.
5. Make all connections to Master Control (See Fig.9 below and wiring diagram, page G400.41).
If using breakout stop , provision is made for connecting its lace to the toggle switch lace.

Fig. 9 - Master Control Installation and Connections

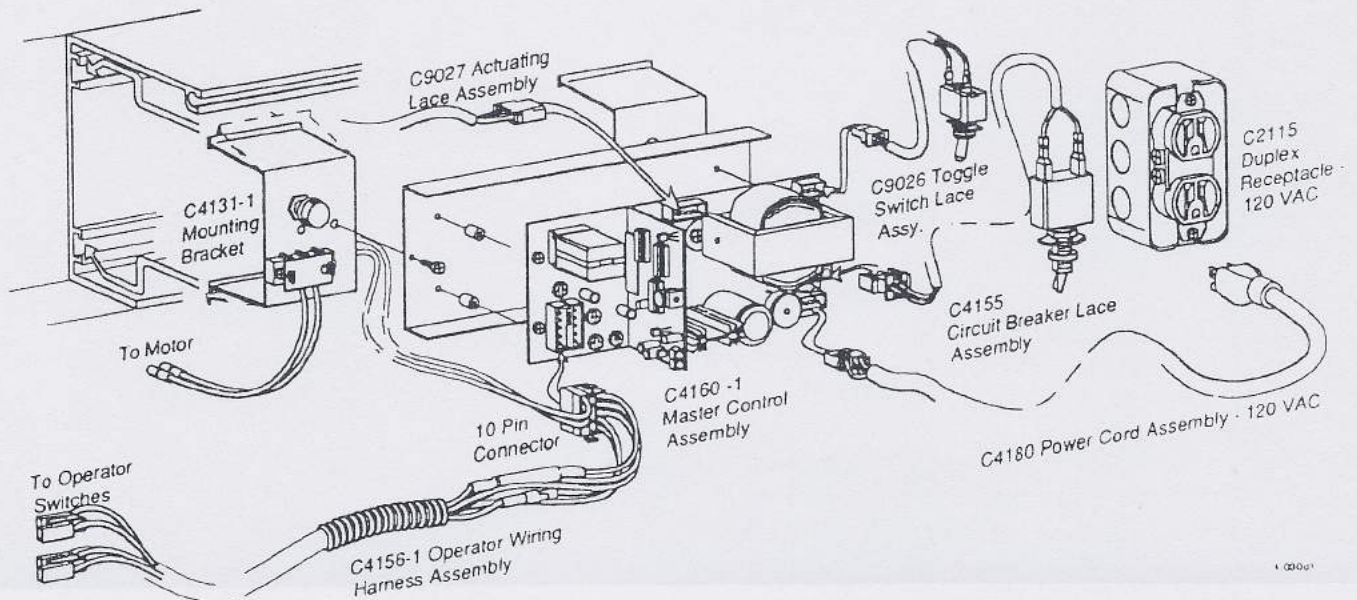

INSTALLATION INSTRUCTIONS FOR SERIES 4100 - SURFACE APPLIED - CONT.

G. Install Adjustable Connecting Arm

Note: For doors without arm clearance, see Part (K) Alternate Step - Parallel Arm Installation.

1. Refer Figures 10 and 11 below and Chart 1 on the next page to determine the proper foot location and method of installation. Install as specified.
2. Determine the proper length of the adjustable rod and cut as required.
3. Assemble the connecting arm and attach it to the mounting foot. Refer to Fig. 12.

Fig. 10 - Installation of Adjustable Connecting Arm and Mounting Foot

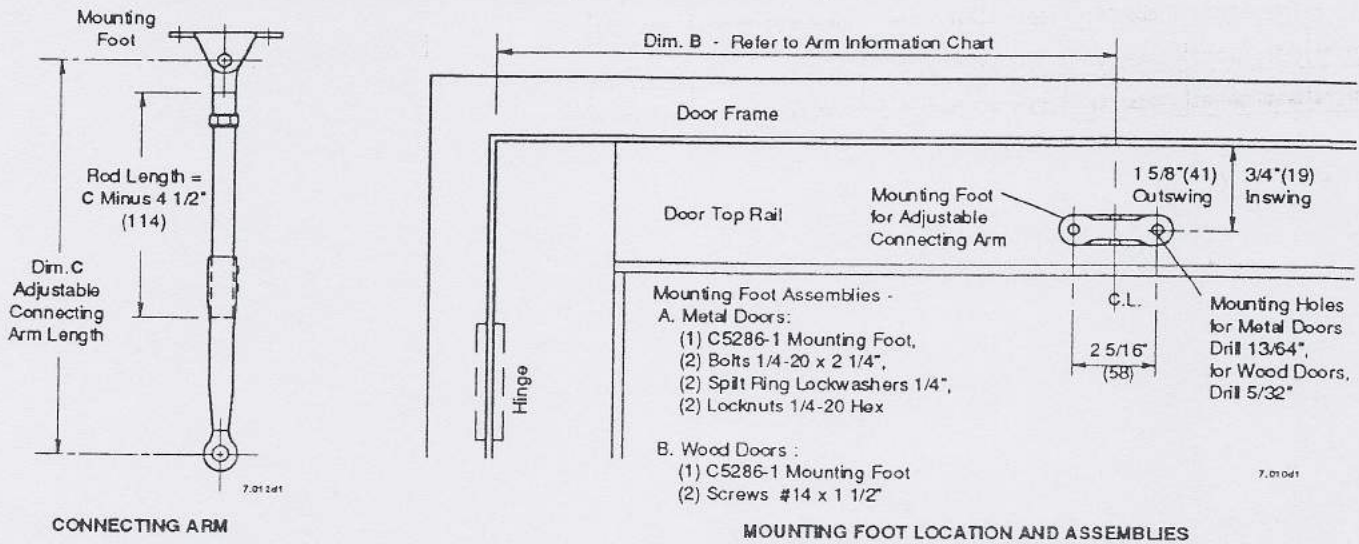

Fig. 11 - Standard Arm Connections - Plan Views

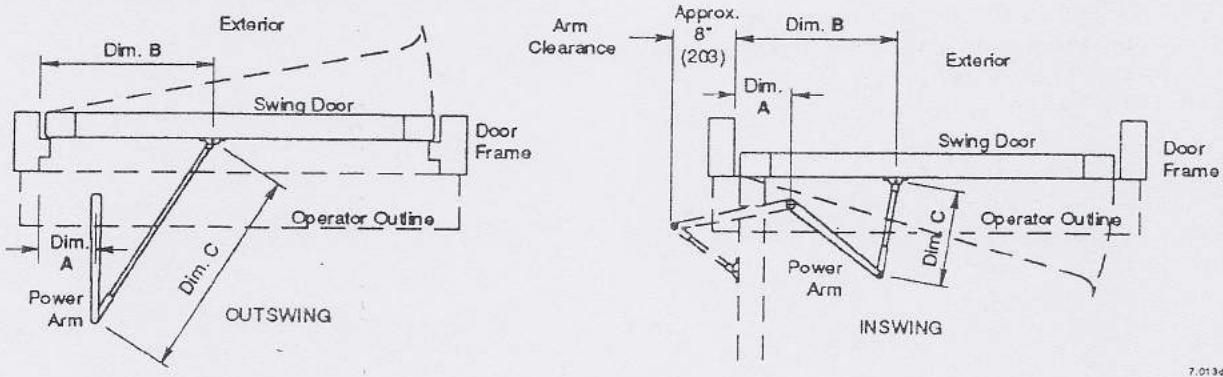
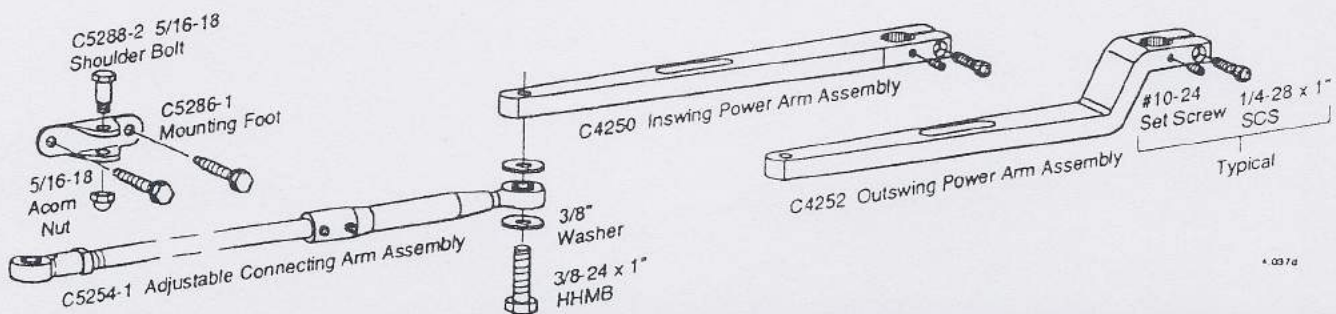

Fig. 12 - Standard Arm Assemblies



INSTALLATION INSTRUCTIONS FOR SERIES 4100 - SURFACE APPLIED -
PART (G) CONT.

Chart 1 - Arm Information

REVEAL	BUTT HINGE OR OFFSET PIVOT						CENTER PIVOT 2 3/4"					
	INSWING			OUTSWING			INSWING			OUTSWING		
	A	B	C	A	B	C	A	B	C	A	B	C
0	4" (102)	13" (330)	10" (254)	4" (102)	16" (406)	17 1/8" (435)	4" (102)	17" (432)	9" (229)	4" (102)	16" (406)	16 1/2" (419)
1/2" (13)	4" (102)	13" (330)	10" (254)	4" (102)	16" (406)	17 1/2" (445)	4" (102)	17" (432)	9" (229)	4" (102)	16" (406)	16 7/8" (429)
1" (25)	4" (102)	13" (330)	10" (254)	4" (102)	16" (406)	17 3/4" (451)	4" (102)	17 1/2" (445)	9 1/2" (241)	4" (102)	16" (406)	17" (438)
1 1/2" (38)	4" (102)	14" (356)	10" (254)	4" (102)	16" (406)	18 1/4" (464)	4" (102)	17 1/2" (445)	9 1/2" (241)	4" (102)	16" (406)	17 3/4" (451)
2" (51)	4" (102)	14" (356)	10 1/2" (268)	4" (102)	16" (406)	18 1/4" (464)	4" (102)	18" (457)	10" (254)	4" (102)	17" (432)	18 3/4" (476)
2 1/2" (64)	4" (102)	14" (356)	11 1/2" (268)	4" (102)	16 1/2" (419)	19 1/4" (489)	4" (102)	19" (483)	10 1/2" (268)	4" (102)	17" (432)	19" (483)
3" (76)	4" (102)	15" (381)	12 1/2" (268)	4" (102)	16 1/2" (419)	19 3/4" (502)	4" (102)	19" (483)	10 1/2" (268)	4" (102)	18" (457)	20" (508)
3 1/2" (89)	4" (102)	16" (406)	11" (279)	4" (102)	16 1/2" (419)	20 1/8" (511)	4" (102)	19" (483)	10 1/2" (268)	4" (102)	18" (457)	20 1/2" (521)
4" (102)	4" (102)	17" (432)	12" (305)	4" (102)	17" (432)	20 3/4" (527)	4" (102)	25" (635)	17" (432)	4" (102)	19" (483)	21 1/2" (546)

Note: If Reveal is greater than 4" consult factory.

H. Setting the Open Stop and Loading Operator Spring

Caution: When installing the power arm or when servicing any swing door operator, be sure to keep your face, hands and arms clear of the power arm's swing path. **Serious injury** could result should the operator be accidentally activated to an open position or should the operator return to a relaxed position.

The power arm must be located correctly on the knurled output shaft so that when the operator is fully open the door will be positioned at a 90° angle from its frame. Also, the operator spring must be pre-wound so that the operator will be under spring force when closed. By following one of the next two methods, you will simultaneously set the open stop and load the spring.

Method No.1 (Recommended): Manually open the door to 90° (or as specified). Energize the operator so the operator rotates the shaft to the full open position against its internal stop; this action simultaneously winds spring. With the arm adjusted to the proper length and connected to the foot, slip the power arm on the output shaft then tighten the socket-head cap screw to 10 foot pounds of torque. Tighten set screw * through side of arm into shaft. De-energize the operator; it should close against the door stop.

* Note: On Direct Drive power arms, the set screw prep. has been eliminated.

Method No.2 (Used only when no power is available): Manually open the door to 90°. With the foot connected to the door and the adjustable connecting arm attached to the power arm, slip the power arm on the output shaft, but do not tighten. Mark the position of the slot on the output shaft. Remove the arm, rotate 240° in the opposite direction and reinstall. Tighten to 10 foot pounds of torque. A torque wrench is recommended. Now tighten set screw through side of arm into shaft. Reconnect at connecting arm (thus manually winding spring) and manually close the door.

To ensure arm cannot walk-off of shaft, install both screw and washer into predrilled hole in the bottom of the output shaft.

INSTALLATION INSTRUCTIONS FOR SERIES 4100 - SURFACE APPLIED -
PART (H) CONT.

Fig. 13 - Two Methods of Setting the Open Stop and Loading Operator Spring

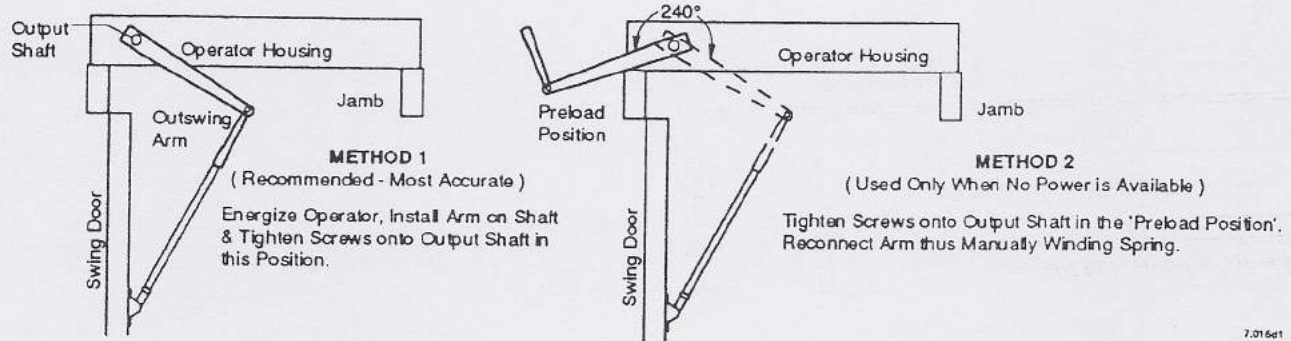

I. Install Floor Stop

A permanent floor mounted stop is recommended for stopping the door in the full open position because this will protect the operator from abuse. When this method is used, ensure the stop does not create a trip hazard.

J. Check Door Operation

Proceed to adjust operator control and cams as outlined on page G400.40.

K. Alternate Step - Parallel Arm Installation

Note: Required on inswing doors without arm clearance .

1. Verify that the power arm is the correct hand. If it isn't, it can easily be converted . Refer to Fig.16 next page.
2. Use Fig. 14 and 15 to determine the proper track location and method of installation. Install as specified. Attach C4556 Drive Block Assembly to Track Assembly as specified.
3. Energize the operator and install the power arm with the door in the open position 90° from the face of the door frame. Tighten the 1/4" socket-head cap screw to 10 foot-pounds. Tighten the set screw against the output shaft.
4. Proceed to adjust the operator control and cams as outlined on page G400.40.

INSTALLATION INSTRUCTIONS FOR SERIES 4100 - SURFACE APPLIED -
PART (K) CONT.

Fig. 14 - Parallel Arm Track Location

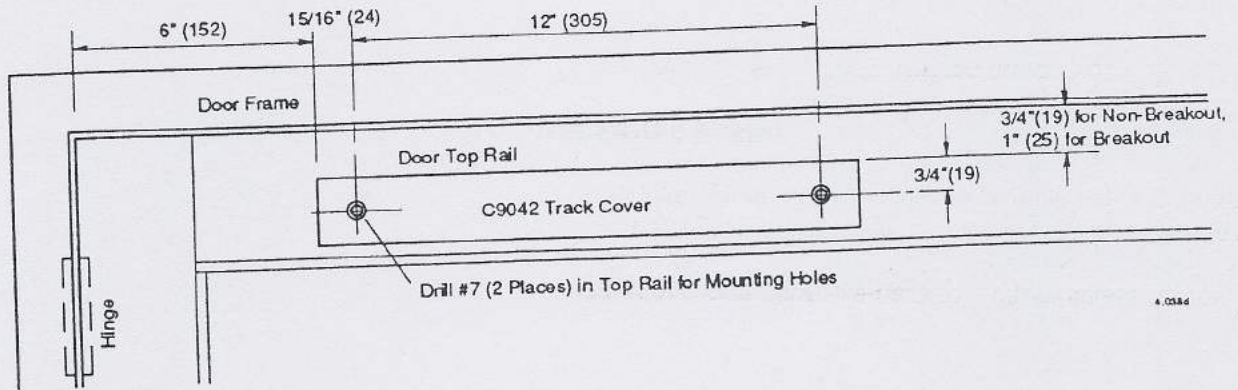

Fig. 15 - Parallel Arm Connections

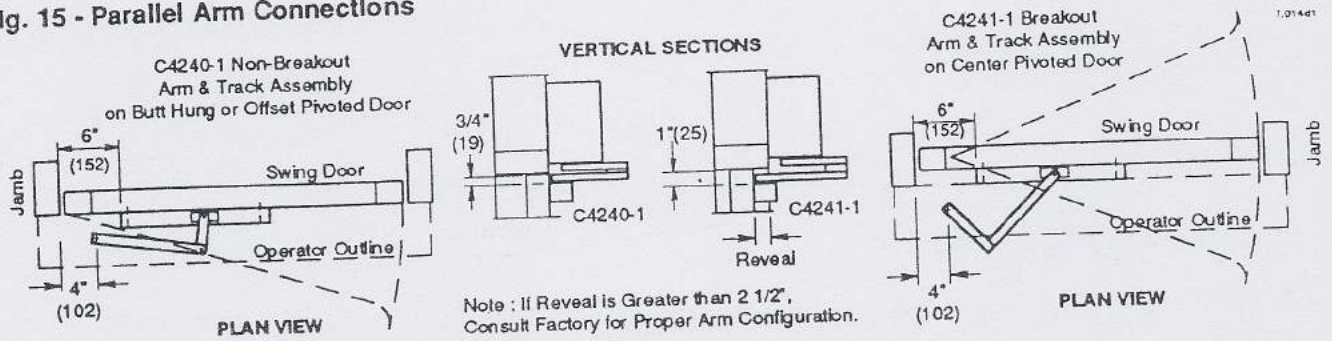
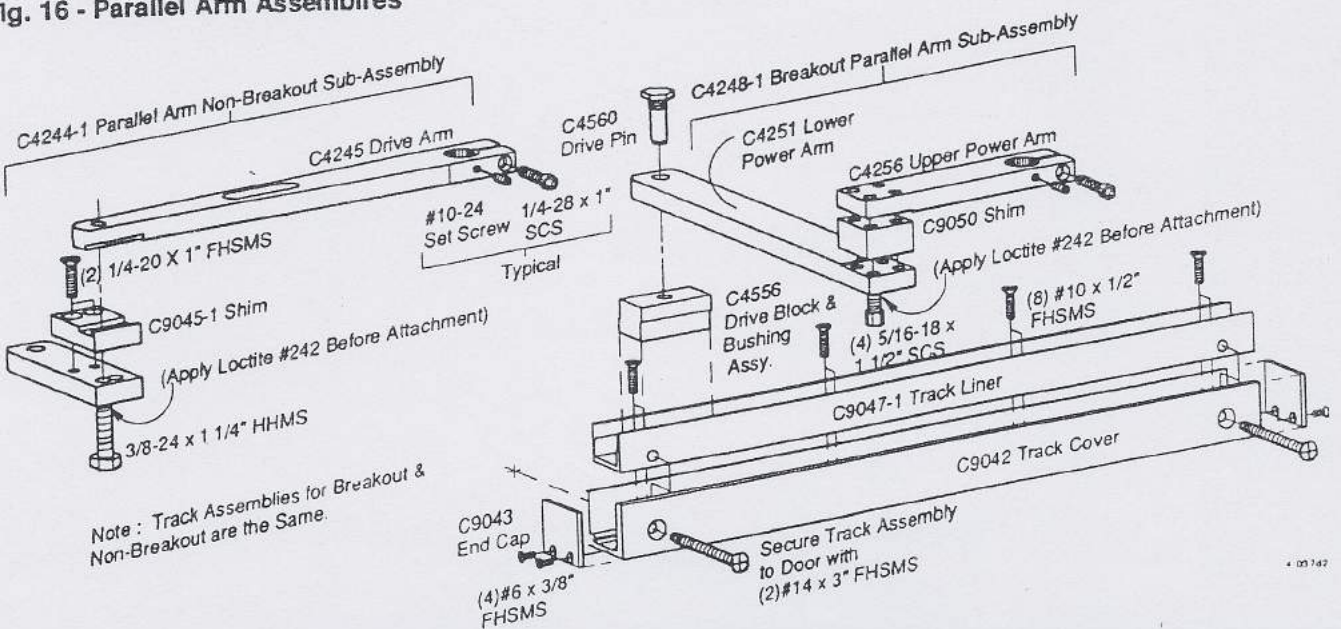

Fig. 16 - Parallel Arm Assemblies



12. INSTALLATION INSTRUCTIONS FOR SERIES 4500 AND 4800 - OVERHEAD CONCEALED

Instructions for installing Side Load and Bottom Load covers are similar. The basics of both installations are included on the following pages. The side load cover is depicted in most of the drawings.

Refer to page G400.7 for verification of Operator hand. For the installation of the Junction Box and the Controls, see pages G400.10 and G400.11 respectively. Refer to these same pages if it is necessary to install the Operator. The methods outlined are similar.

A. Assemble Frame

Series 4500: All frame assembly holes drilled at factory. Assemble as shown in Fig.17 for Side Load or Fig. 18 for Bottom Load. Allow for 120 VAC service and activating lace. (2 wires).

Series 4800: Use adhesive-backed jamb template to locate header mounting holes. Drill with 1/2" bit. Assemble as shown in Fig. 17 or Fig. 18.

Fig. 17- Side Load Frame Assembly

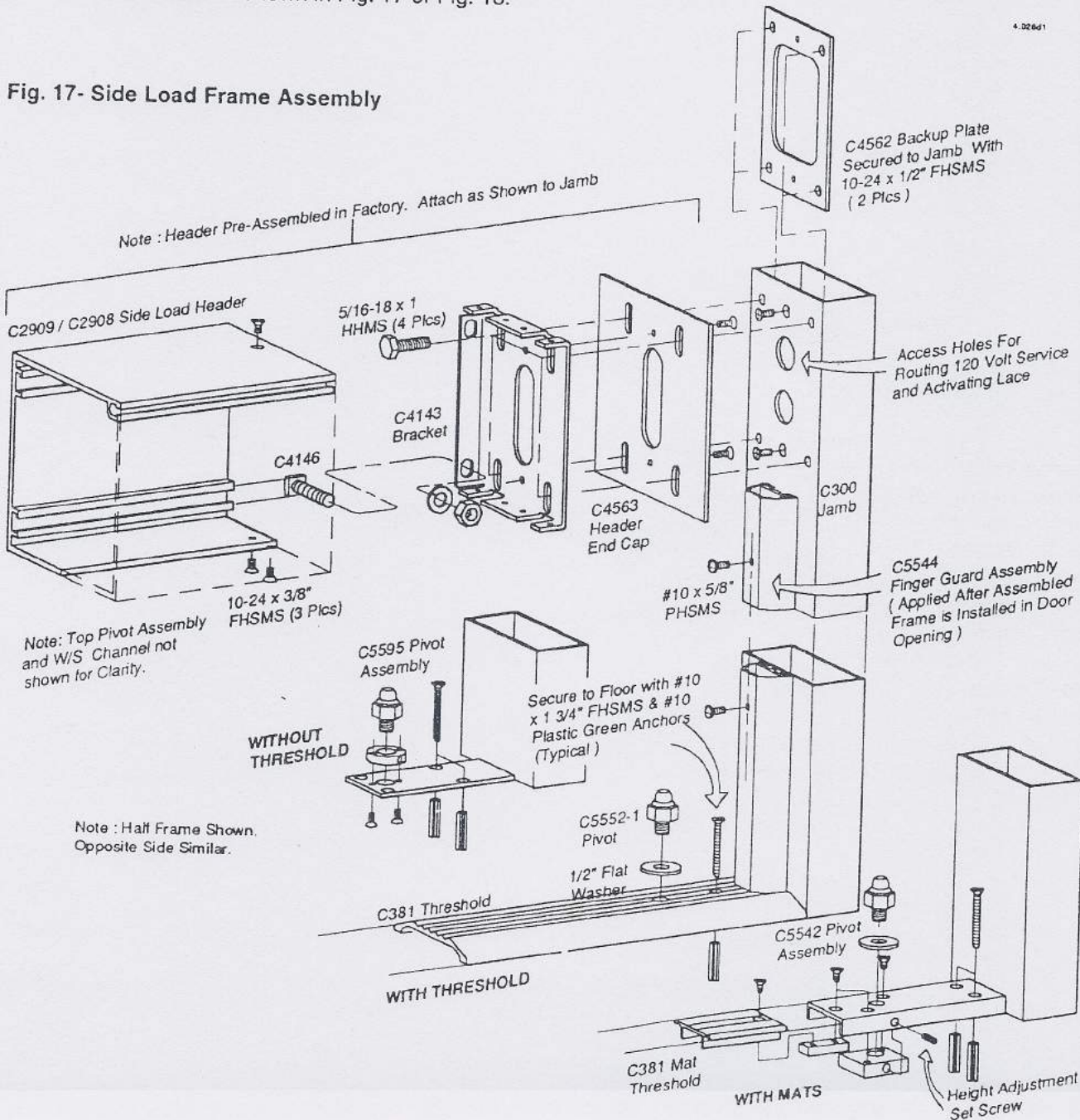

INSTALLATION INSTRUCTIONS FOR SERIES 4500 AND 4800 -
OVERHEAD CONCEALED - PART (A) CONT.

Fig. 18 - Bottom Load Frame Assembly

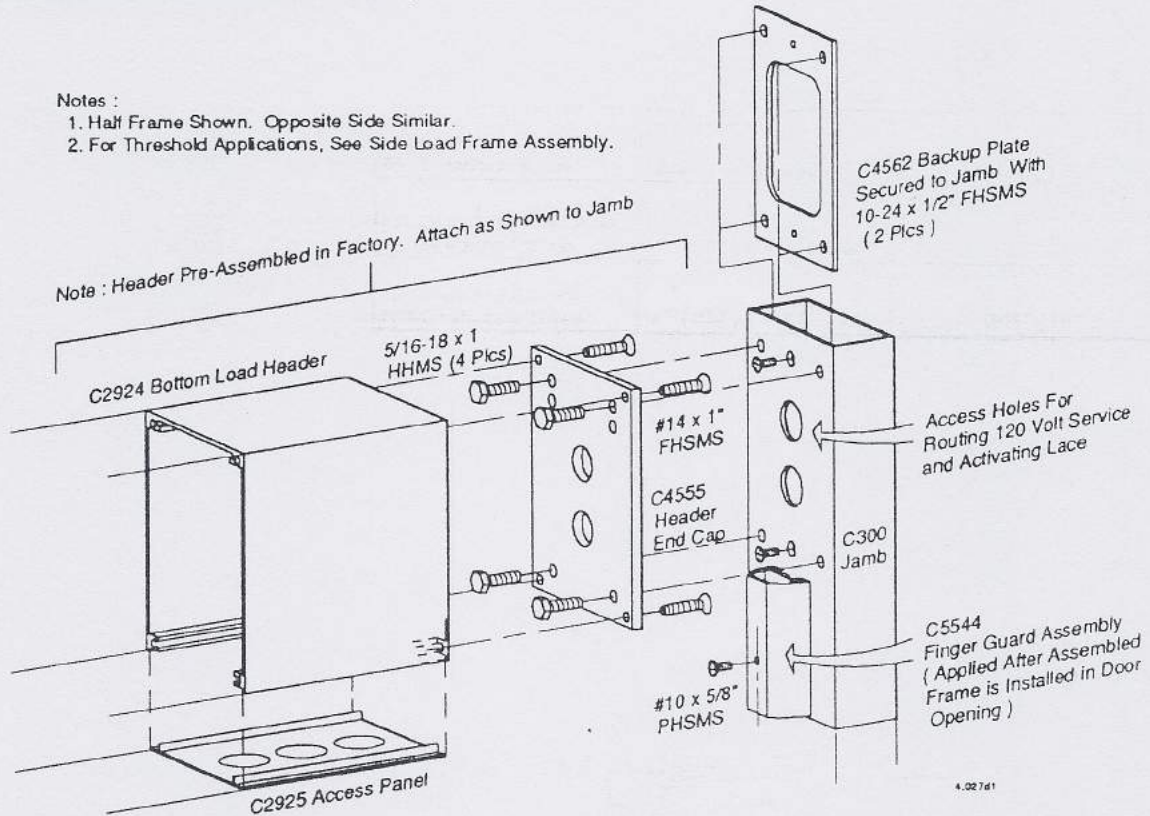

B. Install Door Frame

Take care that the Frame is not racked and that the wire laces are out of the way to eliminate any damage to them. Refer to Fig. 19 on next page.

All the fasteners needed to install Swing door are provided with each unit. However, alternate fasteners and preps may be necessary for different installation applications. Refer to Chart #2 on next page for a list of fasteners and their prescribed preps.

1. Set the door Frame into the prepared opening. Be sure the door unit faces the correct side. The Faceplate is usually on the interior side. Also, provisions for getting power to the headers junction box should have been made.
2. The floor condition under the door opening and swing area should be level. If not and there are high points in the floor area, the door frame should be set with the bottom of the bottom pivot assembly and level with the highest point of the floor under the opening.
3. Level and plumb the door frame. Continue leveling as Jambs are secured.
4. Secure Header. Note: when tightening fasteners be careful not to shift the header out of alignment.
5. Secure applicable bottom pivot assembly (See Fig. 17, previous page). Drill 1/4" (6mm) diameter hole to the floor and attach bottom pivot with # 10 x 1 3/4 FHSMS and plastic anchors.

INSTALLATION INSTRUCTIONS FOR SERIES 4500 AND 4800 -
OVERHEAD CONCEALED - PART (B) CONT.

Chart 2 - Fastener Size and Prep

FASTENER SIZE / TYPE	CLEARANCE DRILL / C'SINK	SH. METAL FASTENER DRILL HOLE	TAP DRILL	TAP SIZE	MASONRY APPLICATIONS
#6 Sheet Metal Screw and #6-32 Machine Screw	#25 (.149) and #6 C'Sink	#31 (.120)	#36 (.106)	#6-32	
#10 Sheet Metal Screw and #10-24 Machine Screw	#7 (.201) and #10 C'Sink	#21 (.159)	#25 (.149)	#10-24	Drill 1/4" (.25) and use C1423 Green Plastic Anchor
#14 Sheet Metal Screw and #1/4-20 Machine Screw	#F (.257) and #14 C'Sink	3/16" (.187)	#7 (.201)	#1/4-20	Drill 5/16" (.312) and use C1424 Blue Plastic Anchor

Fig. 19 - Frame Installation

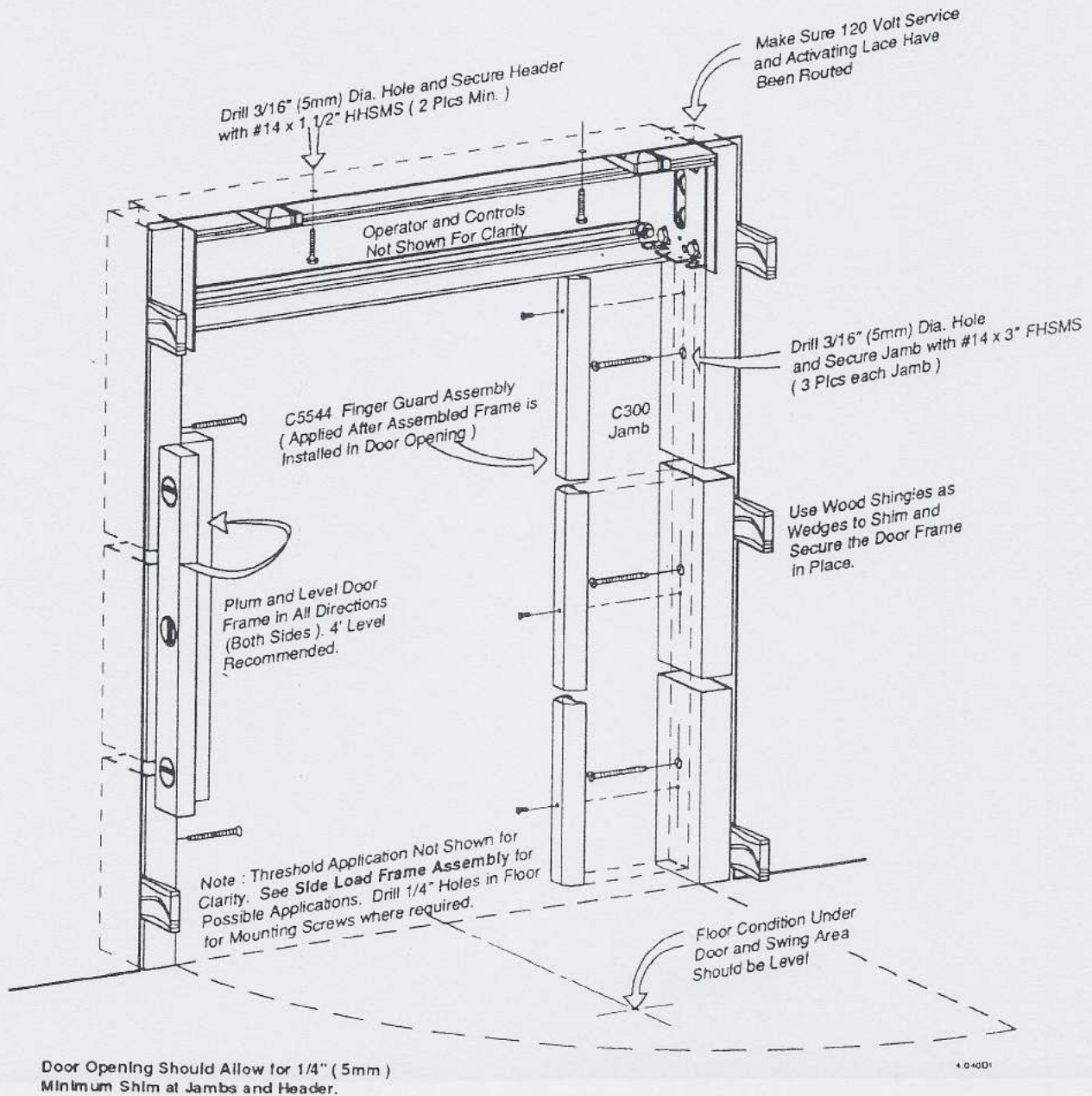

INSTALLATION INSTRUCTIONS FOR SERIES 4500 AND 4800 -
OVERHEAD CONCEALED - CONT.

C. Door Preparation and Installation of Pivots

Note: For Direct Drive, see Part (D) Alternate Step.

Series 4500: Door prep'd at factory. Mount pivots and track as shown in Fig. 20 and Fig. 21 below.

Series 4800: Drill holes as shown in Fig. 20 and Fig. 21 below. Mount pivots and Track.

Fig. 20 - Top Pivot and Door Prep.

Note: Door Top Horizontal Rail Must Have 1" Minimum Top Web Space. Shim Under Pivot and Track as Required.

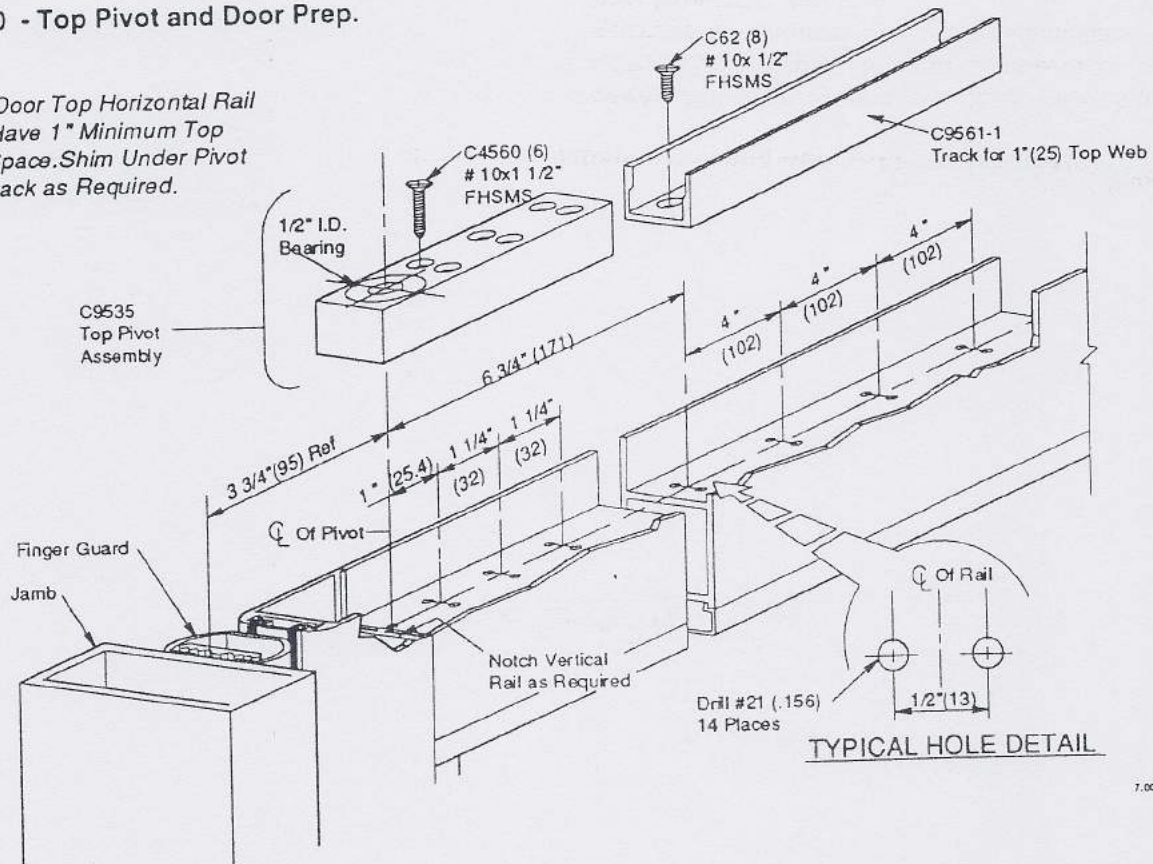

7.006d

Fig. 21 - Bottom Pivot and Door Prep.

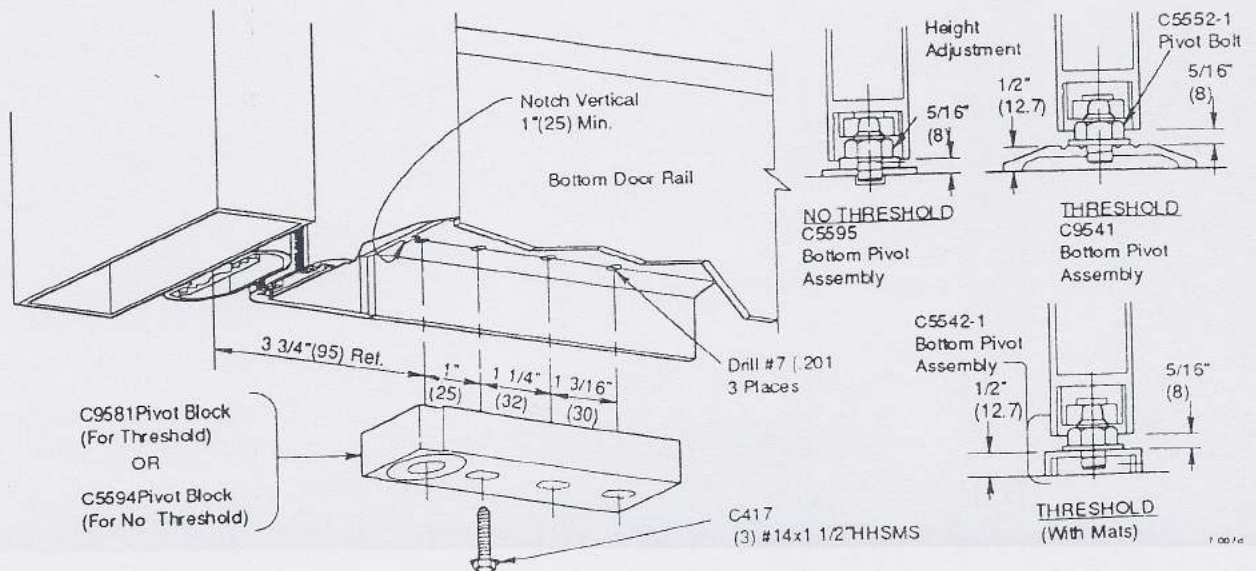

7.007e

INSTALLATION INSTRUCTIONS FOR SERIES 4500 AND 4800 -
OVERHEAD CONCEALED - CONT.

D. Alternate Step - Direct Drive Installation and Door Preparation

Note: Independent Drive as outlined on the previous page is recommended.

Series 4600: Door prep'd at factory.

Series 4700: Drill holes as shown in Fig. 22 and Fig. 23 below.

1. Energize operator, shaft will rotate to full open position. Maintain operator in this position until door panel is installed.
2. Secure power arm onto output shaft tightening 1/4" socket-head cap screw to 10 foot-pounds.
3. Position door under power arm and over floor pivot.
4. Secure power arm to door as shown. Secure floor pivot as shown.

Fig. 22 - Arm Installation and Door Prep. - Direct Drive

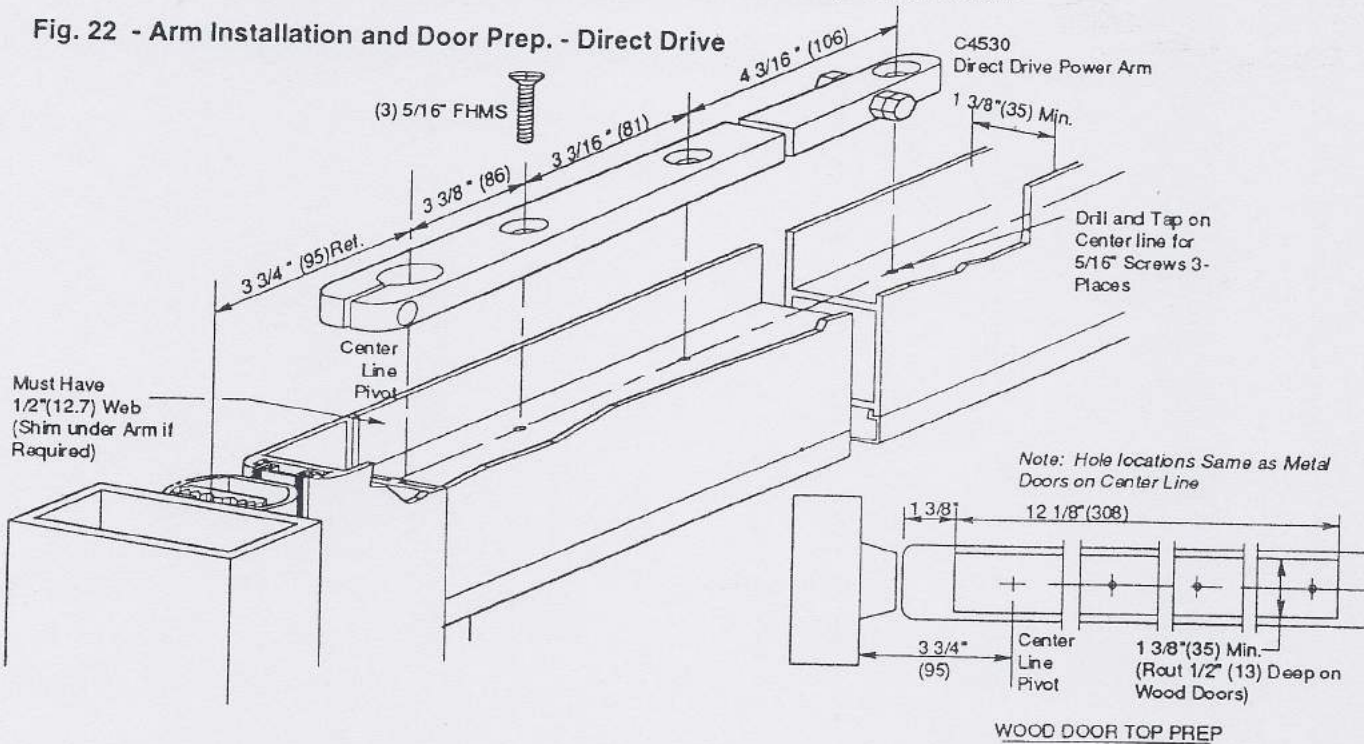
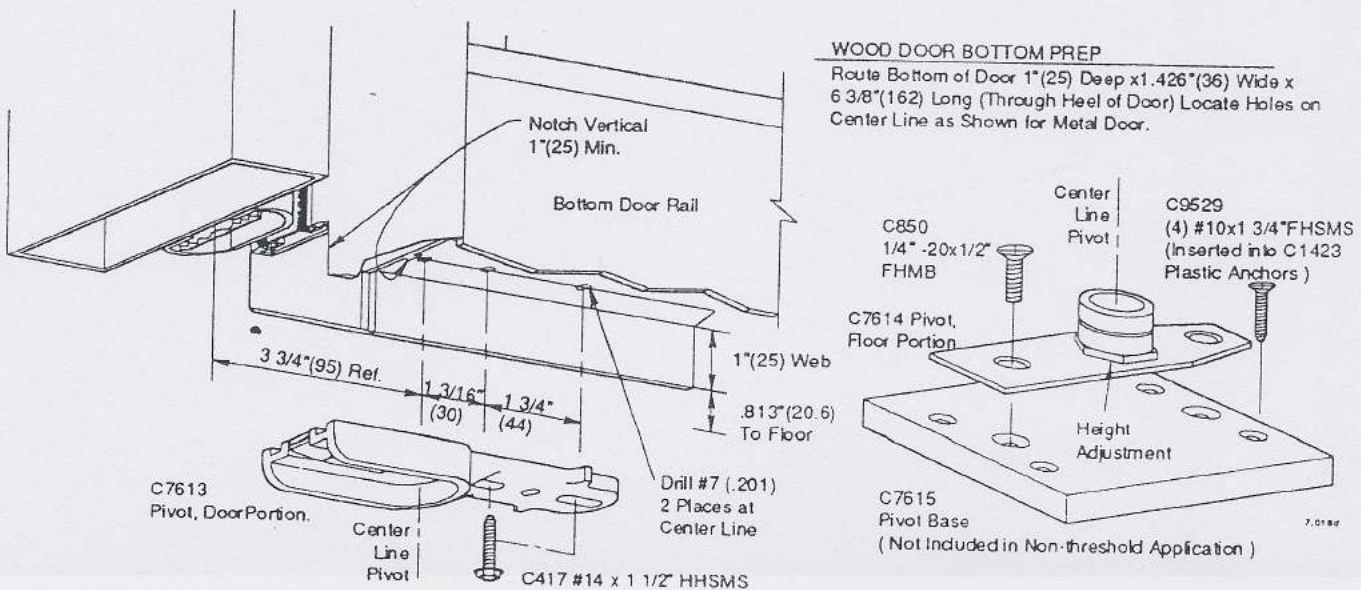
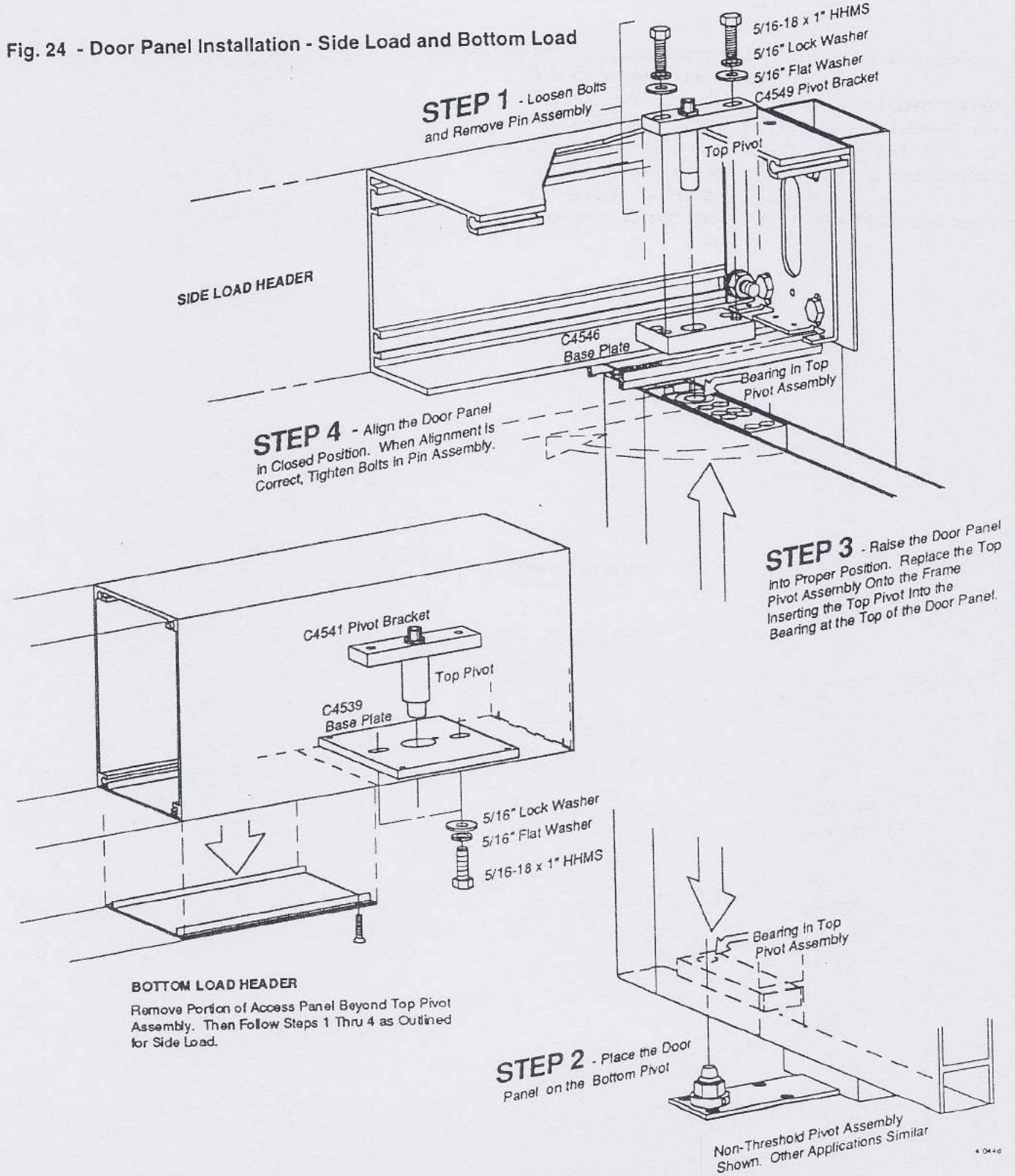

Fig. 23 - Bottom Pivot and Door Prep. - Direct Drive



INSTALLATION INSTRUCTIONS FOR SERIES 4500 AND 4800 -
OVERHEAD CONCEALED - CONT.

E. Install Door Panel



INSTALLATION INSTRUCTIONS FOR SERIES 4500 AND 4800 - OVERHEAD CONCEALED - CONT.

F. Install Power Arm

The power arm must be located correctly on the output shaft so that when the operator is fully open the door will be positioned at a 90° angle from its frame. Methods of installation for Side Load and Bottom Load are the same. Side Load is shown below.

1. Manually open door to 90°.
2. Energize operator, shaft will rotate to full open position.
3. Place slide block in track and position arm so that one of the three holes in the power arm lines up with the hole in the slide block while keeping the door at 90°.
4. Slip the power arm onto the shaft. Use a torque wrench to tighten the 1/4" socket head cap set screw to 10 foot-pounds.
5. Insert the C4560 Pin through the top of the arm and into the block below.
6. Tighten the C4560 drive pin bolt to 25 foot-pounds.
7. Allow the door to close and ensure the arm is parallel to the header and top of the door rail.

Note: If arm needs to be adjusted, refer to Part (G) and Fig. 26 and the following page.

Caution: When installing the power arm or when servicing any swing door operator, be sure to keep your face, hands and arms clear of the power arm's swing path. **Serious injury** could result should the operator be accidentally activated to an open position or should the operator return to a relaxed position.

Note: To ensure arm cannot walk-off of shaft, install screw and washer into predrilled hole in the bottom of the output shaft.

Fig. 25 - OHC Power Arm Installation

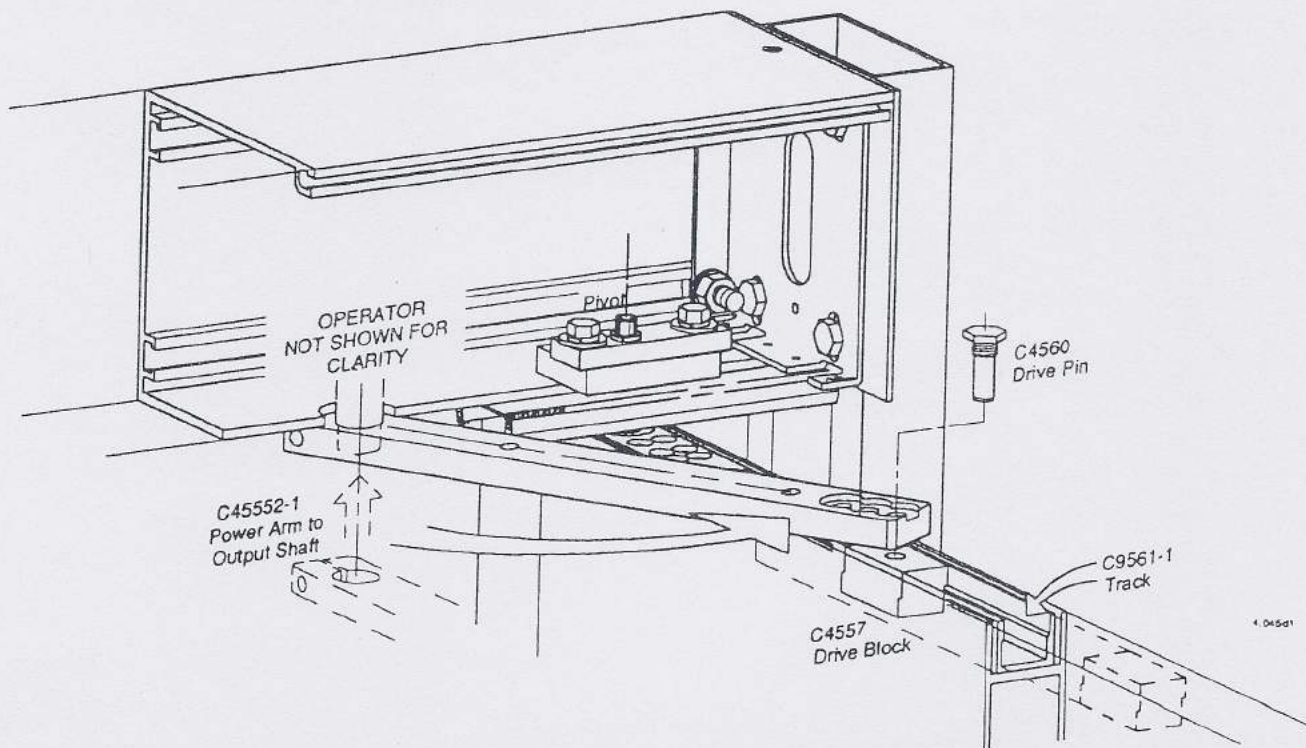

INSTALLATION INSTRUCTIONS FOR SERIES 4500 AND 4800 -
OVERHEAD CONCEALED - CONT.

G. Check Door Operation

1. Manually open door and check drive block as it travels in track. It should not bind. If it works improperly, the power arm must be adjusted parallel to track.
2. To adjust door to 90° at full open, drive pin may be inserted at three different locations. Moving drive pin closer to operator shaft decreases door opening.
3. Secure fixed stop or emergency breakout stop, whichever is being used.

Caution: If the door is equipped with an emergency breakout stop, it should be tested several times to be sure the stop flips over and cuts off the switch when the door is pushed through. It will automatically flip back when the door is pushed back through it to the normal position. If it does not work properly, the door height may need adjusting at bottom pivot.

It is also important to install the proper cam on operator when breakout stop is used. This is a backup safety device. Should the emergency breakout stop fail to cut off the operator, the cam will operate the door in backcheck speed. *Note: This became a standard feature in 1987. Operators manufactured prior to 1987 will accept this cam setup. It should be added to these operators as they are routinely serviced. Simply remove the existing C4024-2 cam and install the C4024-3 back check cam in its place.*

4. After glazing, adjust the door leveler screw in the top rail of the door close to the vertical strike rail. **Door must not drag at any point.**
5. For final adjustments, see Item 16 "Adjusting the Operator for Code Compliance" in this manual.
6. Replace access plate and power arm cover.

Fig. 26 - Plan - OHC Power Arm and Door Layout

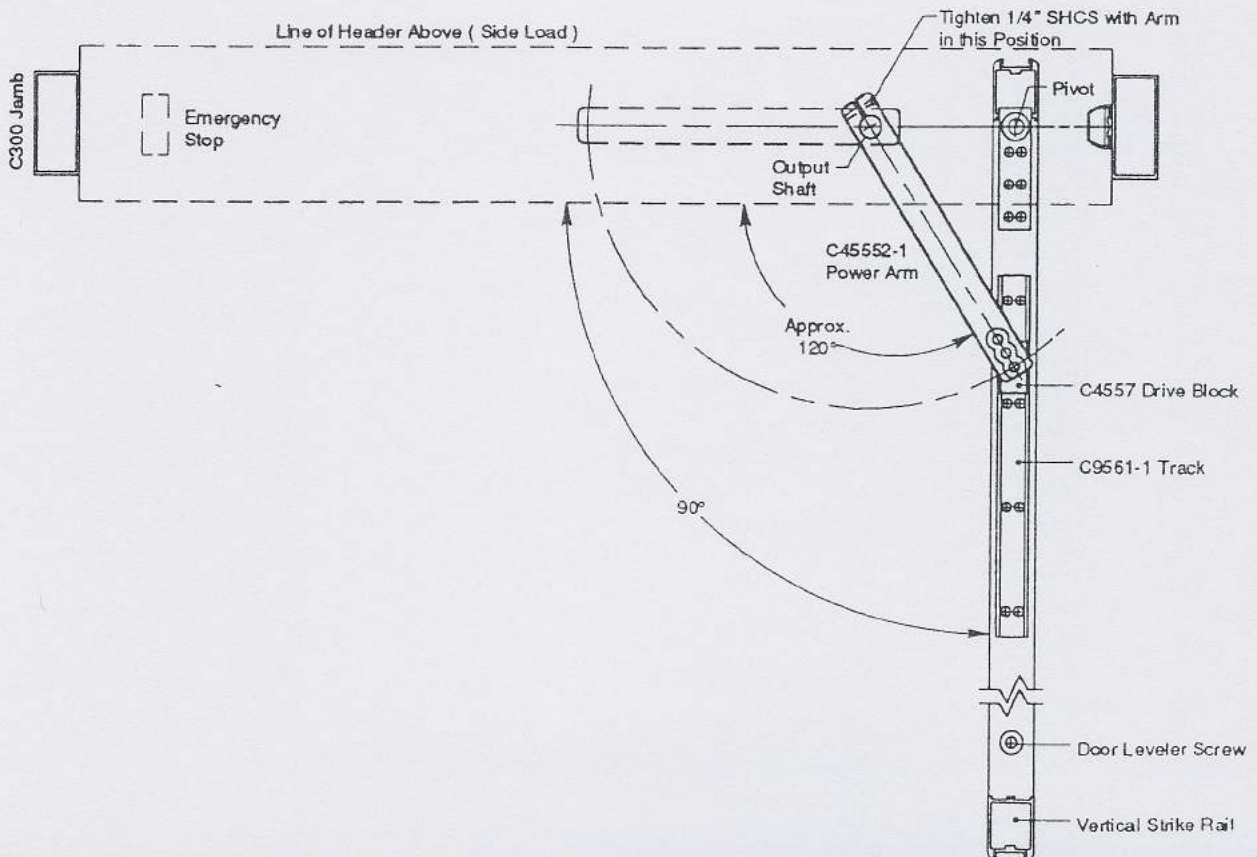

13. ACTIVATING DEVICES AND SAFETY SYSTEMS

Horton Automatics offers a choice of popular activating devices and safety devices. Proper selection of these devices is critical to the safe use of the automatic door. ANSI A156.10 provides information to the manufacturer, designer, and installer for proper use of activating devices. The designer must ensure proper sizes and devices are specified. The installer should ensure they comply with Horton Automatics' recommendations and the applicable standards.

Guide rails and a safety zone should always be provided on the swing side of the door. The exception to the safety zone is a low-energy operator such as Horton Automatics Series 7000 EasyAccess™ Operator.

A. Motion Detectors

Product description: The C1801 microwave motion detector is a self-contained device consisting of the microwave transmitter, receiver, antenna, signal amplifier, and signal processing circuits. The unit provides a relay contact closure to activate the door's operating mechanism. The unit is solid-state and composed of the highest quality and most reliable components available.

Generally, the detector is mounted on the door header. The unit is aimed downward in front of the door to provide an oval shaped detection zone. Two adjustable pattern sizes are offered; See Fig. 27.

When motion is detected in the active zone, the system signals the operator's master switch to open and hold the door open as long as motion is continuous. When motion is no longer detected, the operator's adjustable time-delay times out and the door closes unless other safety zone detectors are occupied and giving an open signal. But, the door will immediately reopen upon the detection of the minimum level of motion from a moving object.

Fig. 27- C1801 Motion Detector and Zone Patterns

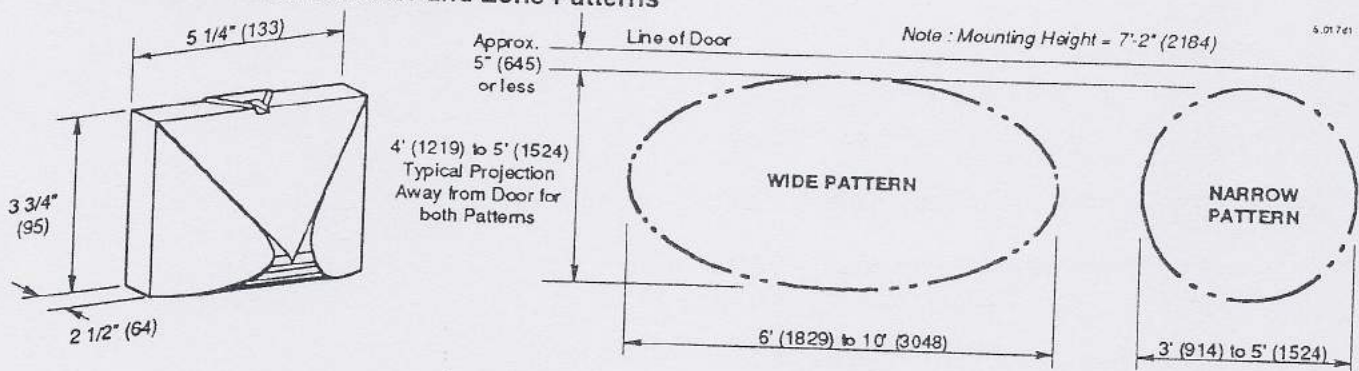

Features:

- Adjustable sensitivity
- Will operate at -30° F to +122° F
- Durable noncorrosive materials, black finish
- Will detect a small object moving at a rate of 60 inches per second (Normal walking rate is 18 inches per second)
- Can be used in an exposed outdoor environment
- Proven circuitry and components
- Class II 12 - 24 VAC/VDC operating voltage
- 6 W max. power consumption
- 24.525 GHz frequency
- Meets all requirements of FCC regulations – UL: Safety Hazard and Radiation Hazards

Limitations: Motion Detectors do not detect motionless persons or objects. Consequently time delay before closing should be set to consider the slowest moving or stopped traffic and in no case be less than 1.5 seconds. *Note: A large mass moving outside the normal area can cycle the door.*

ACTIVATING DEVICES AND SAFETY SYSTEMS - PART (A) CONT.

Installation and Servicing Requirements: The system does not require the installation of any equipment in the floor. It is unaffected by changes in atmospheric conditions. Snow, water, salt or ice on the floor in the detection zone have no affect on the operation of the system. However, if the detector is directly exposed to the elements, such as sufficient water or snow on the detector cover, problems can occur.

It is recommended that the self-contained units be securely mounted 7'-2' (2184) above the floor and the detection pattern be directed into the desired traffic area. Each sensor is factory tuned to one of four frequencies of about 24.125 GHz. A potentiometer adjustment is provided and this enables the installer to adjust the pattern sensitivity to the door use requirements. *Note: The detector can be mounted up to 10 feet (3048 mm) above the floor but sensitivity and pattern size will be affected.*

The detection pattern size must be as wide as the door opening and project a minimum of 54" (1372) out from the door. The installer must adjust the detection pattern to within five inches (1277) or less from the door.

B. "Knowing Act" Activation Devices

The Following switches require a "knowing act" to actuate the automatic door operator:

C529 ON/OFF Key Switch - with maintained contact to remove power to switch and/or operator (shown below in Fig. 28).

C530 ON/OFF Key Switch - with momentary contact for actuation. Spring returns to OFF position.

C1260 Push Plate Wall Switch - 6 1/4" (159) Dia. brushed stainless steel plain plate with momentary contact microswitch assembly. The switch assembly mounts to a standard 4" x 4" x 1 1/2" (102 x 102 x 38) junction box. *Note: the junction box is not included in the assembly.*

C1260-1 Push Plate Wall Switch - same as C1260 except with engraved "PUSH TO OPEN"

C1260-3 Push Plate Wall Switch - same as C1260 except with engraved handicap logo.

C1260-4 Push Plate Wall Switch - same as C1260 except with engraved 'PRESS TO OPEN" and handicap logo (shown below in Fig. 28).

C1269 Push Plate Wall Switch - 4" x 4" (102 x 102) blue anodized aluminum plate.

C1315-2 Pushbutton Switch - microswitch with 1" (25) Dia. red pushbutton and junction box assembly. The junction box is 4" x 4" x 1 1/2" (102 x 102 x 38) molded plastic with 1/8" (3) thick blue plastic cover with raised white letters and handicap logo. For use in handicap designated areas requiring a push-to-operate switch.

Note : Optional wireless transmitters available for all push plate and pushbutton switches.

Fig. 28 - Activation Devices

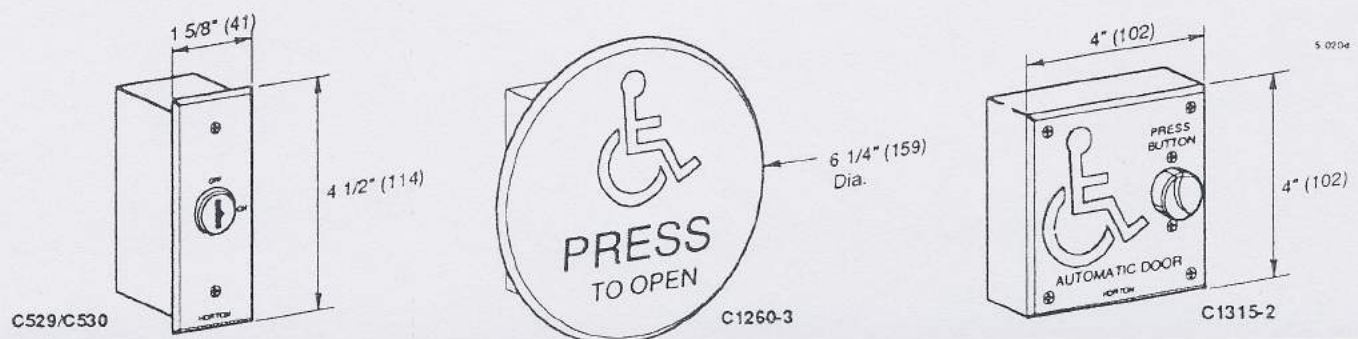

ACTIVATING DEVICES AND SAFETY SYSTEMS - CONT.

C. Electric Mats

Product description: The electric mat has been used for many years as an effective method of both activating automatic swing doors and providing safety. The following is a basic mode of operation :

- Activating Mat (Approach).....Will open or recycle the door at any time provided the safety mats are unoccupied
- Safety Mat.....Deactivates approach mat or holds door open which has been previously actuated by approach mat (will not open or recycle door).

The mat is constructed of ribbed durable plastic. The standard color is brown. Other colors, gray, red, blue and green can be provided at a nominal cost. Standard emblems – In, Out, Welcome, Thank You, Arrows and custom emblems – are also available.

Limitations: The floor surface must be flat and smooth. The mat life will be shortened considerably if it is installed overlapping an expansion joint. If heavy loads cross over the mat, the mat should be temporarily protected by a rigid cover. If heavy loads consistently use the opening, another type of activating switch, such as a Motion Detector, should be used.

Installation: Mats should fit within the door frame. See Chart 3 for available mat sizes. ANSI A156.10 standard requires mat to be centered in the walk-through door opening.

Note: Selecting the correct mat size is critical for proper door operation and safety.

Mats are to be installed with metal edge trim (See Fig. 30). Be careful not to force metal trim inward toward center of mat; heat induced expansion of plates can cause mat to short out if room for expansion is not allowed. Make sure all dirt, dust, shavings, etc. have been removed from around and under the mat before trim is secured.

Fig. 29 - Mat Requirements - Plan

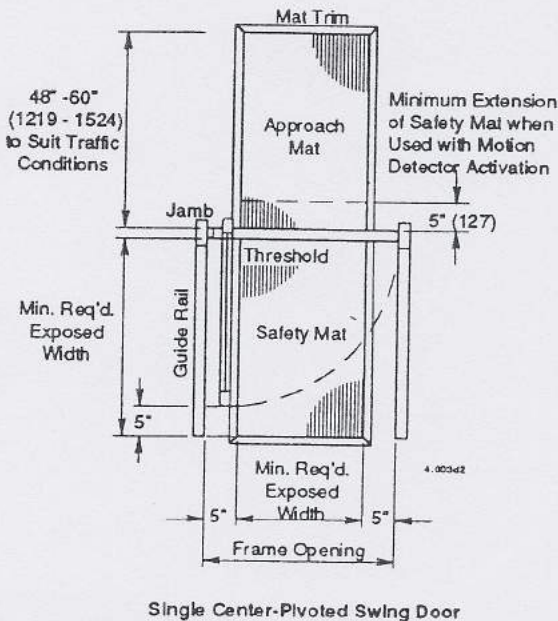

Fig. 30- Trim and Threshold Sections

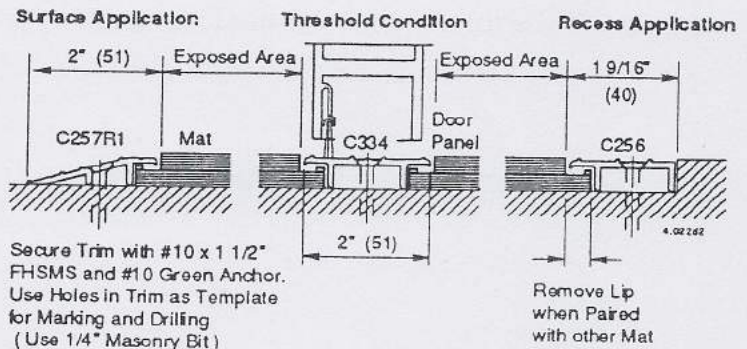

Chart 3 - Standard Mat Sizes

	HORTON NUMBER*	WIDTH (EXPOSED AREA)	LENGTH (EXPOSED AREA)
Use with 3'-0" (914) Doors	3036	28 7/8" (733)	31 3/16" (792)
	3048	28 7/8" (733)	43 3/16" (1097)
	3060	28 7/8" (733)	55 3/16" (1402)
Use with 3'-6" (1067) Doors	3636	34 7/8" (886)	31 3/16" (792)
	3648	34 7/8" (886)	43 3/16" (1097)
	3660	34 7/8" (886)	55 3/16" (1402)
Use with 4'-0" (1219) Doors	4236	40 7/8" (1038)	31 3/16" (792)
	4248	40 7/8" (1038)	43 3/16" (1097)
	4260	40 7/8" (1038)	55 3/16" (1402)

* Note : First two numbers denote nominal width; last two nominal length.

ACTIVATING DEVICES AND SAFETY SYSTEMS - CONT.

D. Guide Rails

ANSI A156.10 requires two guide rails on the swing side of power operated swing doors used by the general public.

Product description: Aluminum guide rails are 1/2" x 4" (13 x 44) solid bar, polished and anodized. Two rail sizes are offered : 42" x 30" (1067 x 762) and 48" x 30" (1219 x 762). Foot (base) is 4" x 4" (102 x 102). Stainless steel tube rails are 1 7/8" (48) dia. x .049" thick with a polished finish.

Panel options include expanded aluminum mesh or solid acrylic PVC composition. Guide rail dividers are 1 3/4" x 1 3/4" (44 x 44) aluminum and can be provided with or without a photoelectric beam.

Fig. 31 - Available Guide Rail Configurations

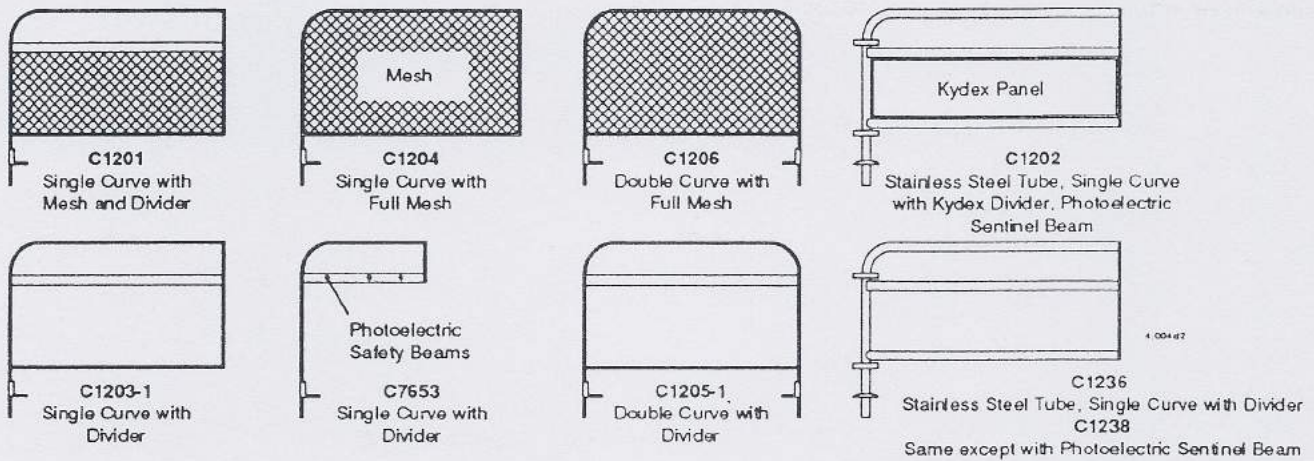

Installation: When Horton jamb-mounted rails are ordered, jambs will be prep'd at factory. Refer to Fig. 32 for size and layout requirements. Refer to Fig. 33 for floor prep. and anchoring details.

Fig. 32 - Guide Rail Layout and Size Requirements

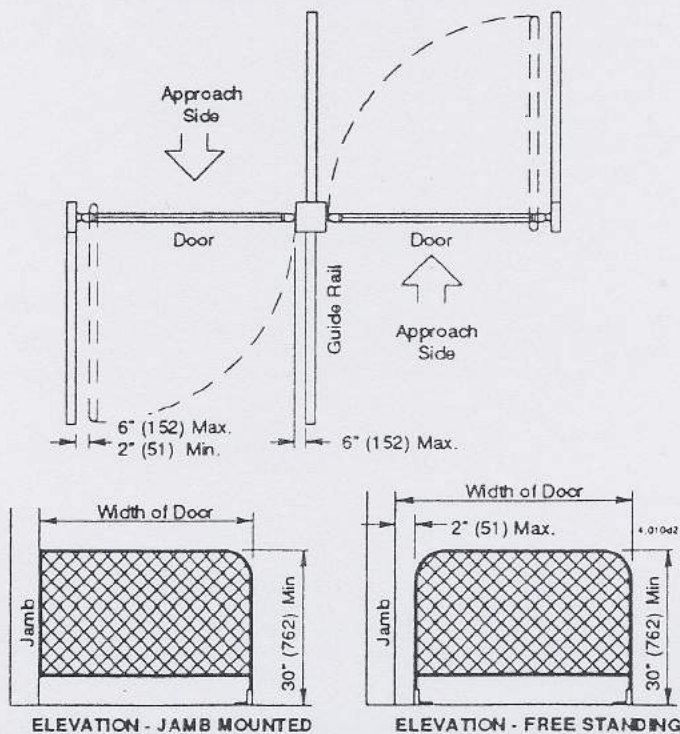
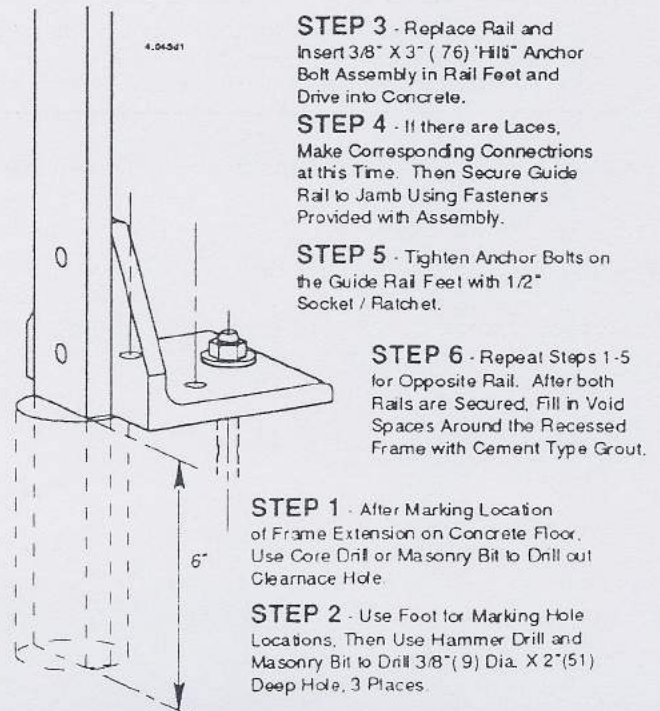

Fig. 33 - Guide Rail Floor Prep. / Anchorage



ACTIVATING DEVICES AND SAFETY SYSTEMS - CONT.

E. Vista Safety Systems

Product description: Vista Systems are the most effective swing door safety packages available. These systems are flexible enough to adapt to various safety needs – from trained employee's in hospitals to the untrained public in retail stores.

Safety of the person on the swing side of the door is central to any automatic swing door system and Vista Safety Systems offer that safety. The systems provide pedestrian safety in compliance with ANSI A156.10.

Door activation is either by motion detector on the approach side or remote push plate switches that can be mounted on both sides of the door to facilitate two-way automatic traffic. (Activation devices are not a part of the Vista Safety System).

Horton Automatics "SwingStop" or "SwingSafe" features are triggered by the Safety Sentinel Beam or door mounted VistaStop Sensor. If the door is opening, either of these features will stop or slow (optional) the door if the beam or scan sensor is interrupted by someone approaching the door from the wrong direction. *Note: Refer to the following two pages for mode of operation.*

Vista II Safety System : Safety sensing is accomplished through the use of an overhead mounted VistaGuard infrared Presence Sensor (C1879), a door mounted VistaScan Safety Threshold Scan Sensor (C1878) and a Safety Sentinel Beam (C1185). Vista II is more economical than the Vista I because it only requires a single Safety Sentinel Beam to monitor either a single door or a pair of doors.

Vista I Safety System : Safety sensing is accomplished through the use of an overhead mounted VistaGuard infrared Presence Sensor (C1879), a door mounted VistaScan Safety Threshold Scan Sensor (C1878), and a door mounted VistaStop Sensor (C1878).

Chart 4 - Vista Safety Systems

PACKAGE COMPONENTS	VISTA I	VISTA II
C1879 VistaGuard Presence Sensor (Header Mounted, Swing Side)	Yes	Yes
C1878 VistaStop Sensor (Door Mounted, Swing Side)	Yes	No
C1878 VistaStop Sensor (Door Mounted, Approach Side)	Yes	Yes
C1185 Safety Sentinel Beam (Mounted on Guide Rail)	No	Yes

Limitations: The VistaGuard Presence Sensor should not be mounted where it will be exposed directly to rain or snow.

Installation: The system must be installed by a qualified Horton Automatics distributor/technician and in its optimum configuration provide protection for pedestrian use of automatic swing doors as required by ANSI A156.10.

Door openings wider than 72" (1828 mm) require two VistaGuard Presence Sensors (C1879) to cover the safety zone and each leaf that is wider than 42" (1066 mm) require another optic in the VistaScan Safety Threshold Scan Sensor (C1878).

In/Out swing doors should have a minimum of 12 inches (305 mm) between the two doors to prevent exiting pedestrians from actuating the ingress motion detector.

A set of guide rails with horizontal bars to provide a mounting location for the photoelectric Safety Sentinel Beam is required on the swing side of the door opening. If a wall is adjacent to the door the guide rail can be eliminated and the horizontal bar that houses the sentinel beam can be mounted to the wall. *Note: Automatic swing door openings using a door mounted Safety Sentinel Scan Sensor have the same guide rail requirements, but a provision to mount the photoelectric Safety Sentinel Beam is not required.*

ACTIVATING DEVICES AND SAFETY SYSTEMS - CONT.

Fig. 34 - Vista I Safety System Operation

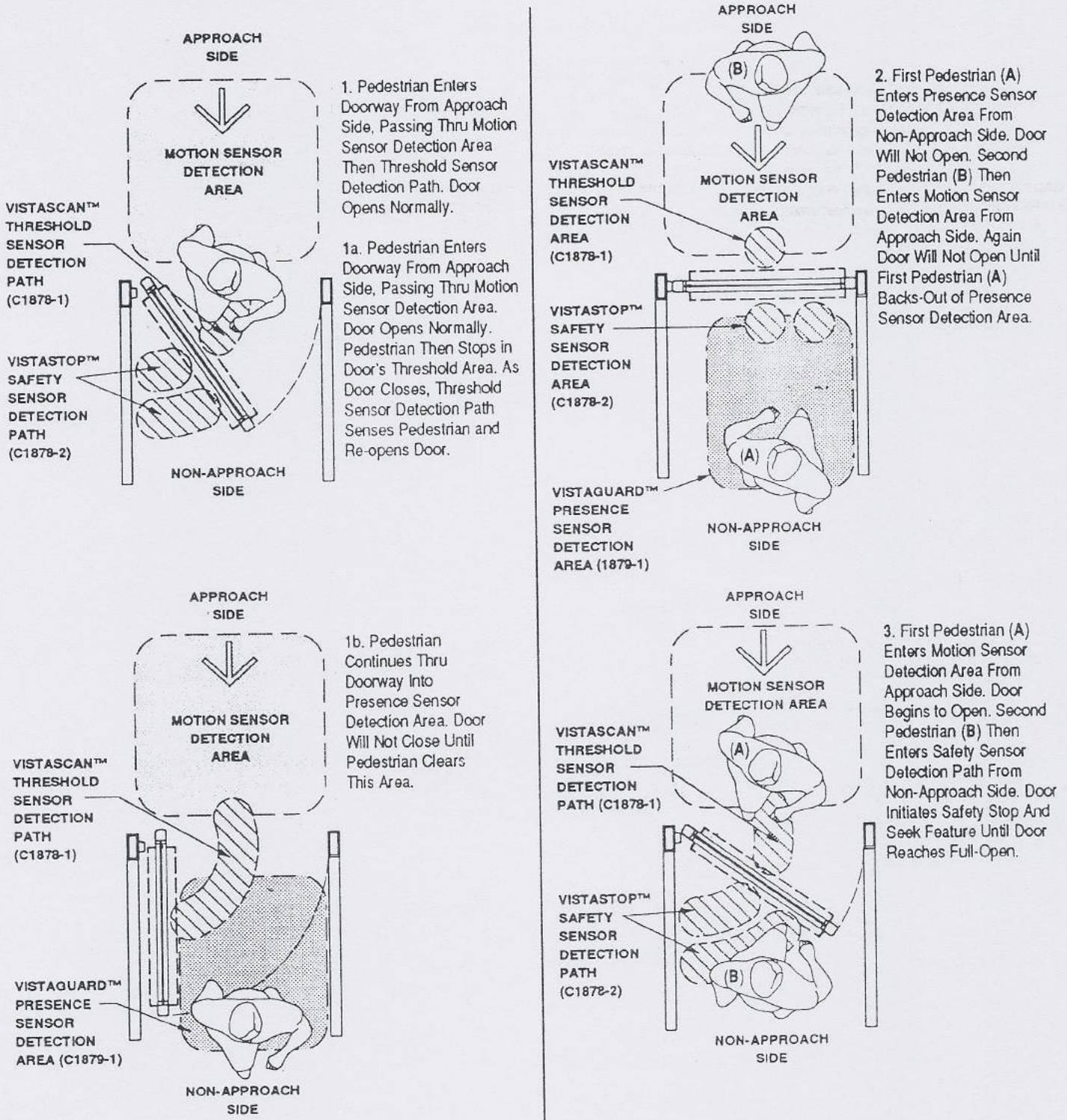

ACTIVATING DEVICES AND SAFETY SYSTEMS - CONT.

Fig. 35 - Vista II Safety System Operation

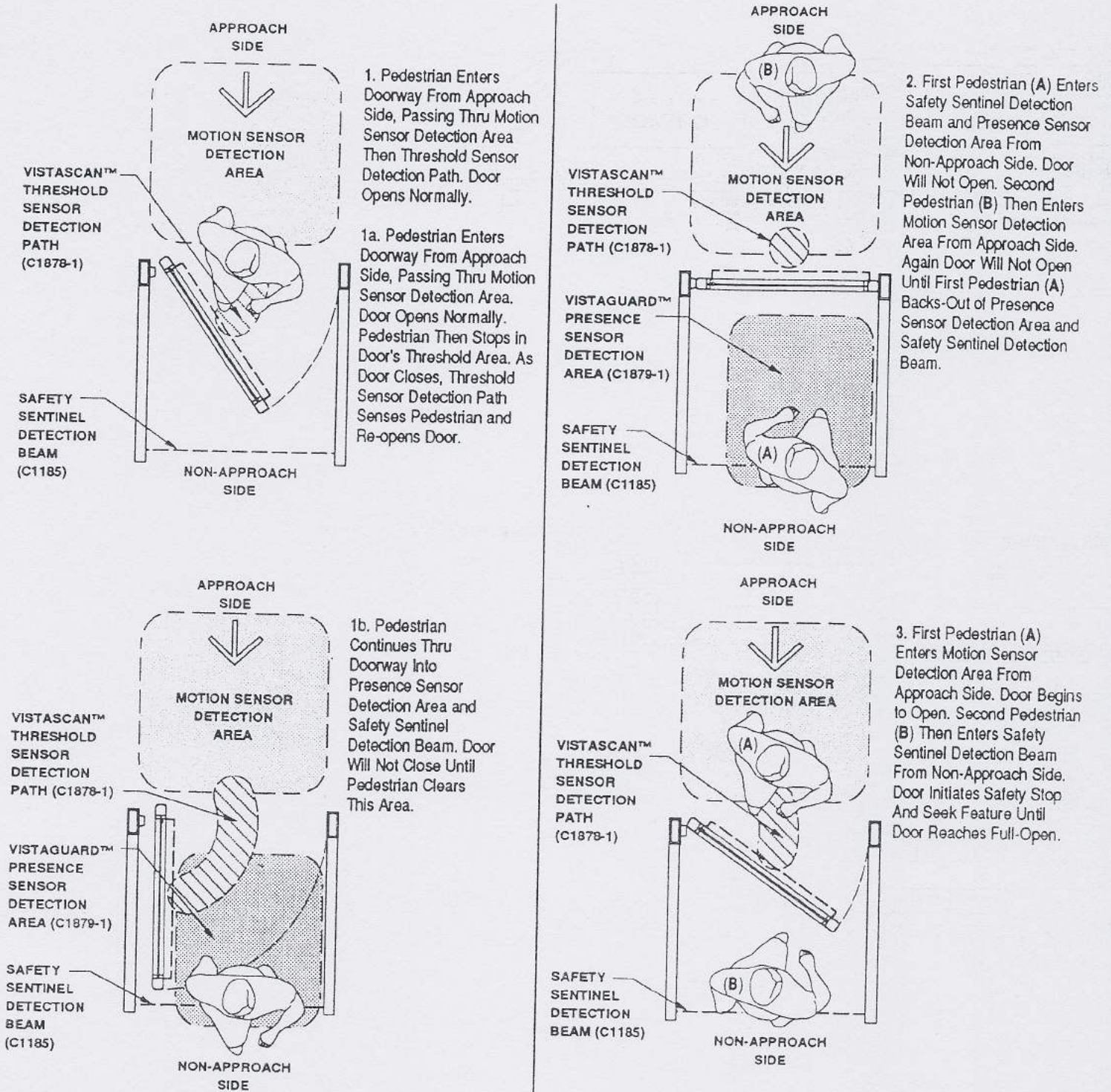

14. WIRING AND MODULE INFORMATION

Fig. 36 - Series 4000 Wiring Schematic for Vista I

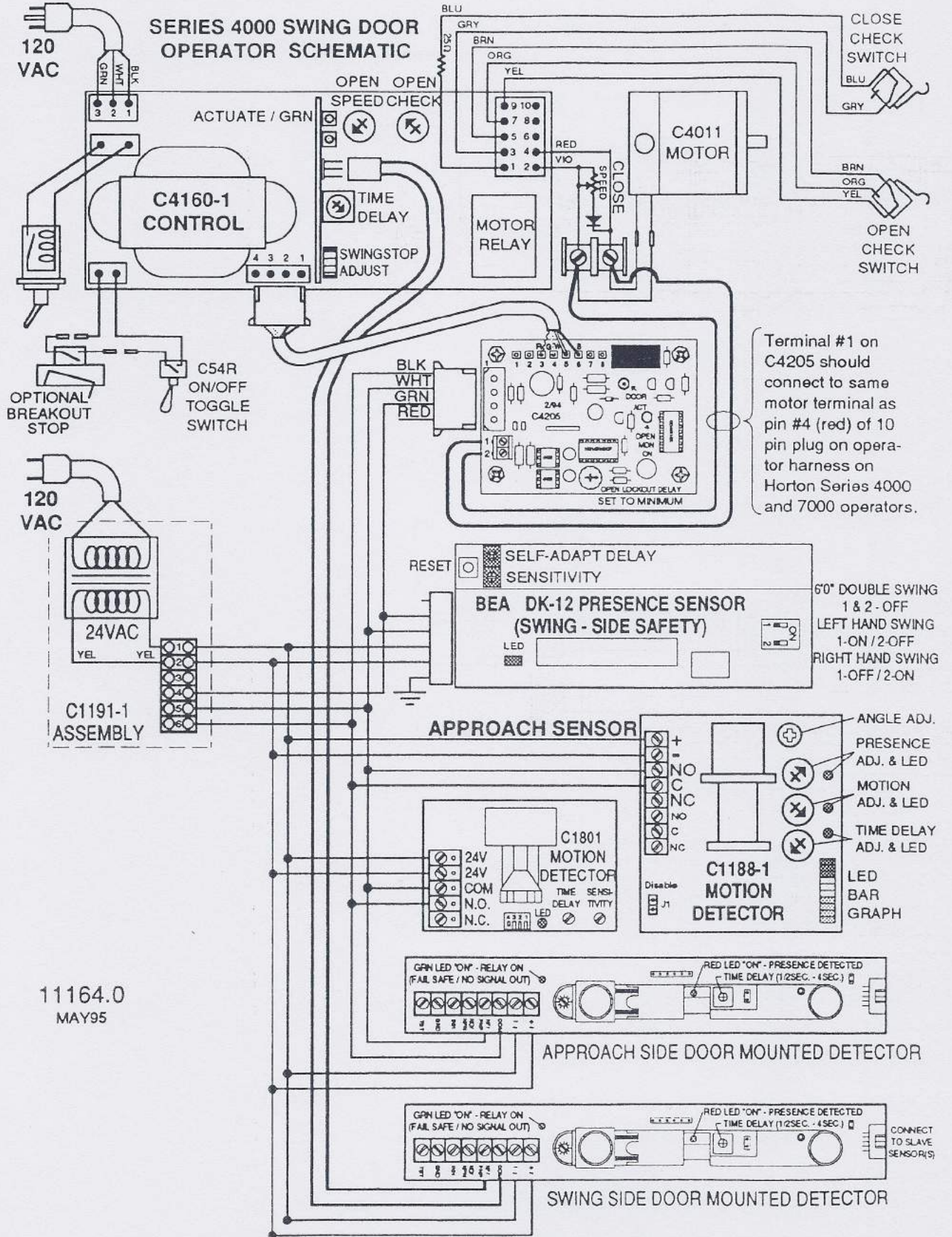

11164.0
MAY95

WIRING AND MODULE INFORMATION : CONT.

Fig. 37 - Series 4000 Wiring Schematic for Vista II

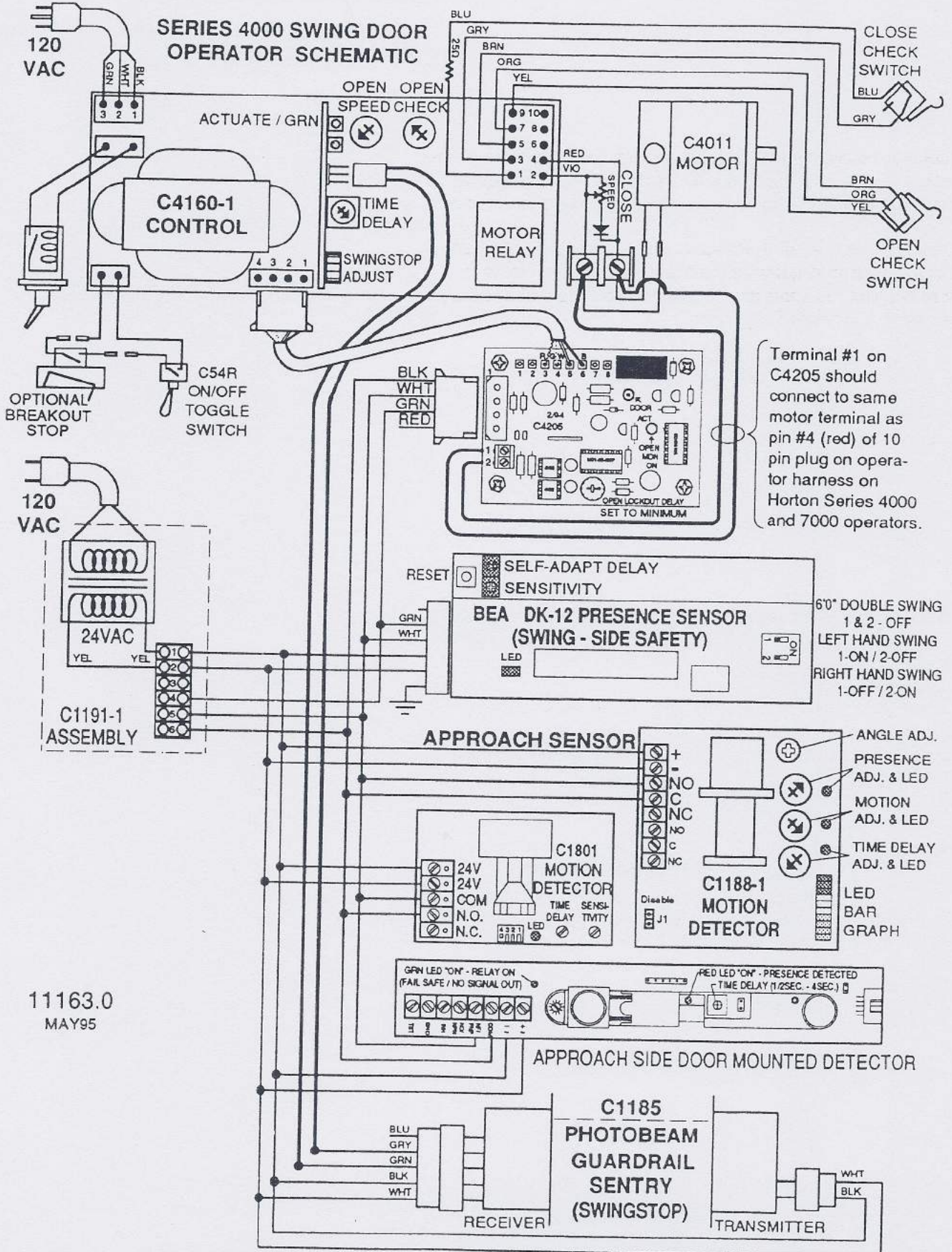

11163.0
MAY95

WIRING AND MODULE INFORMATION - CONT.

The following gives a brief description of seven electronic modules Horton Automatics offers to facilitate the use of automatic doors. Please note we manufacture a number of other accessories; if you do not find what you are looking for here, please call the factory for additional information.

C131-4 Latch Relay Module: Utilizes a momentary contact switch (pushbutton, pull cord, etc.) and provides "latching" or "ratchet" operation of the system. Actuate the switch and the door opens and stays open until the switch is actuated again. It includes a jumper strap that will provide an adjustable time delay override of the latching function and automatically close the door after 15 to 60 seconds.

C2280-1 Multi-Door (4) Interlock Module: A solid-state control that provides interlocked operation of up to 4 automatic door operators, permitting only one door to be open at any given time. When all doors are closed, an actuating signal for any one of the operators will cause the C2280-1 module to send an open command to the corresponding operator. Actuating signals for all other operators are ignored until the open door returns to a fully closed position, as indicated by the required Door Closed Monitor Switches. This unit is not capable of memorizing sequences of actuating switches and automatically sequencing the corresponding doors. Consult factory for this requirement.

C2290-1 Time Delay Module: Provides additional time delay when the door control does not have a time delay, or is not of sufficient length. It can also be used to provide separate delays for various actuating switches, i.e. a door with a motion detector and pushbutton can have a short delay with the motion detector and a longer delay with the pushbutton.

C4150-1: Provides power to the motor on Series 4000 and Series 7000 Swing Door Operators during the closing cycle to assist the spring in fully closing the door. It can be used on installations with high stack pressure, or units with unusually hard latching hardware. It includes the option of removing the power assist close after a delay to re-enable Push-N-Go on Series 7000's.

C4205 Swing Side Sensor Lockout Module: Disables the swing side sensor during the closing cycle of a door. Typically, the swing side sensor will detect the door during closing, actuating the operator's safety circuit. This would require the door to fully close, out of the sensor's pattern, before the door could reopen. No door position switches are required. Additionally, Series 7000 operators, this module will allow the Time Delay Cancel feature to function with approach side sensors. Note: it is strongly advised to add a photoelectric beam beyond the swing of the door to prevent the door from striking someone entering the wrong way after the door has started open.

C7215 Simultaneous Actuation Module: Provides additional inputs for a pair of doors, an input for each door that will open that door only, and a third input to simultaneously actuate both doors.

C7220-1 Strike Interface Module: Provides the required time delays and interfacing when an automatic lock is installed on an automatic door (typically swing doors). A single input will sequentially unlock the lock, then actuate the automatic door operator. Inputs are available for door and lock monitor switches.

WIRING AND MODULE INFORMATION - CONT.

Fig. 38 - Series 4000 Wiring Schematic for C4205 Swing Side Sensor Lockout Module

The C4205 Module's main purpose is to disable a swing area sensor during the closing cycle of a swing door. The swing area sensor is active when the door is fully closed; it is deactivated when the door initially begins to open and is reactivated after a short time delay set by the **OPEN LOCKOUT DELAY** potentiometer. The expiration of this delay is indicated by the illumination of the yellow **OPEN MON ON** LED. When used with a C7160-3 control, pushbutton actuators, and a swing area sensor, adjusting the delay so that the LED does not turn on until the door is in open check will allow full functioning of the C7160-3 Time Delay Cancel feature. Additionally, the swing area sensor signal is routed to the actuate input, eliminating the need for an additional Safety Relay with C7160-3 controls. The green **DOOR ACT** LED indicates the C4205 is sending a request to open to the operator control.

11012.0
JUN94 DPH

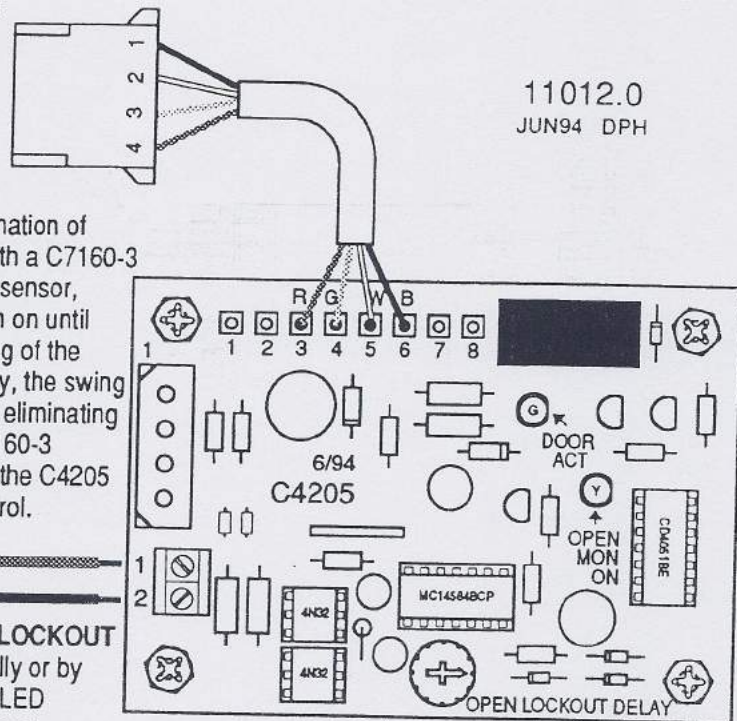

The Motor Monitor Circuit is polarity sensitive. TO CHECK FOR PROPER OPERATION, set **OPEN LOCKOUT DELAY** to minimum and open door (either manually or by electrical actuation). The yellow **OPEN MON ON** LED should turn on during the opening cycle. If it turns on during the closing cycle, reverse the red and black leads on the 2 conductor terminal strip shown above.

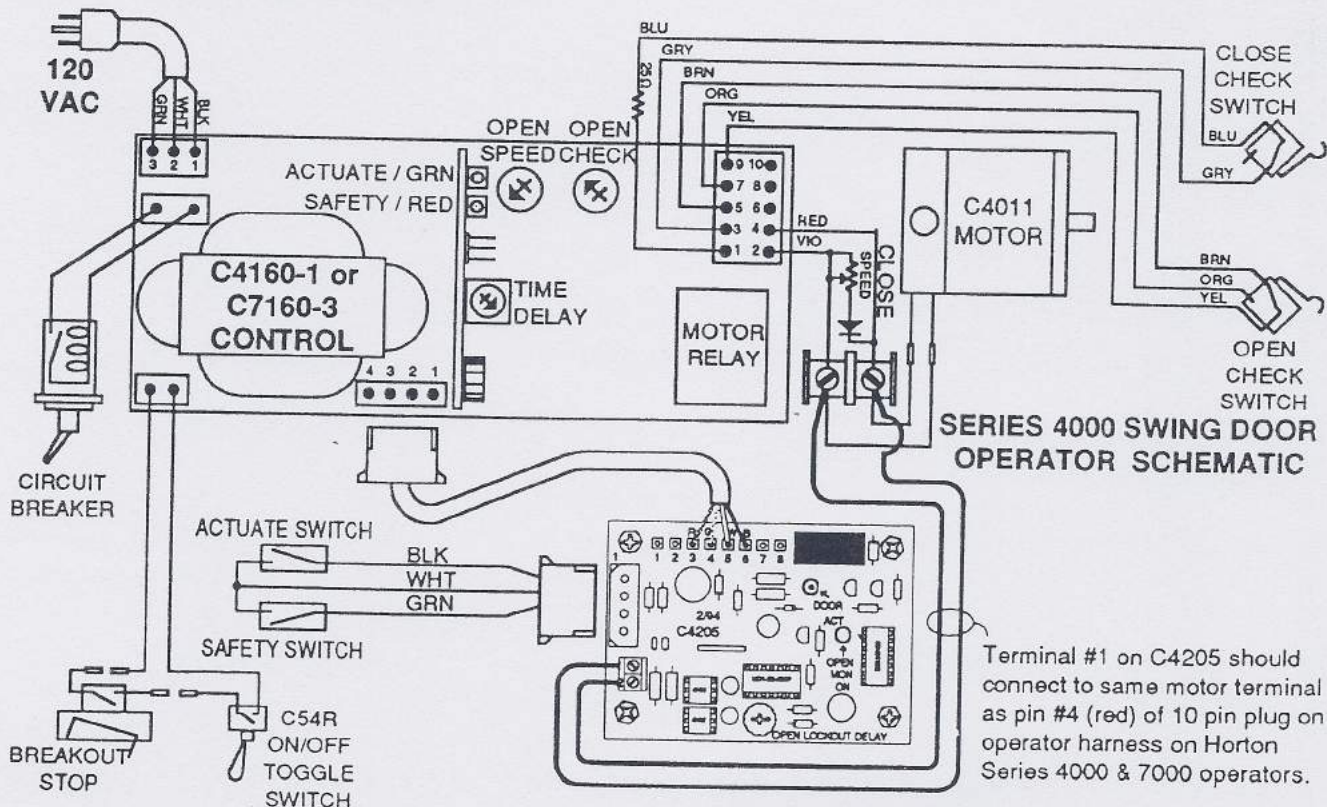

WIRING AND MODULE INFORMATION - CONT.

Fig. 39 - Series 4000 Wiring Schematic for C7215 Simultaneous Actuation Module

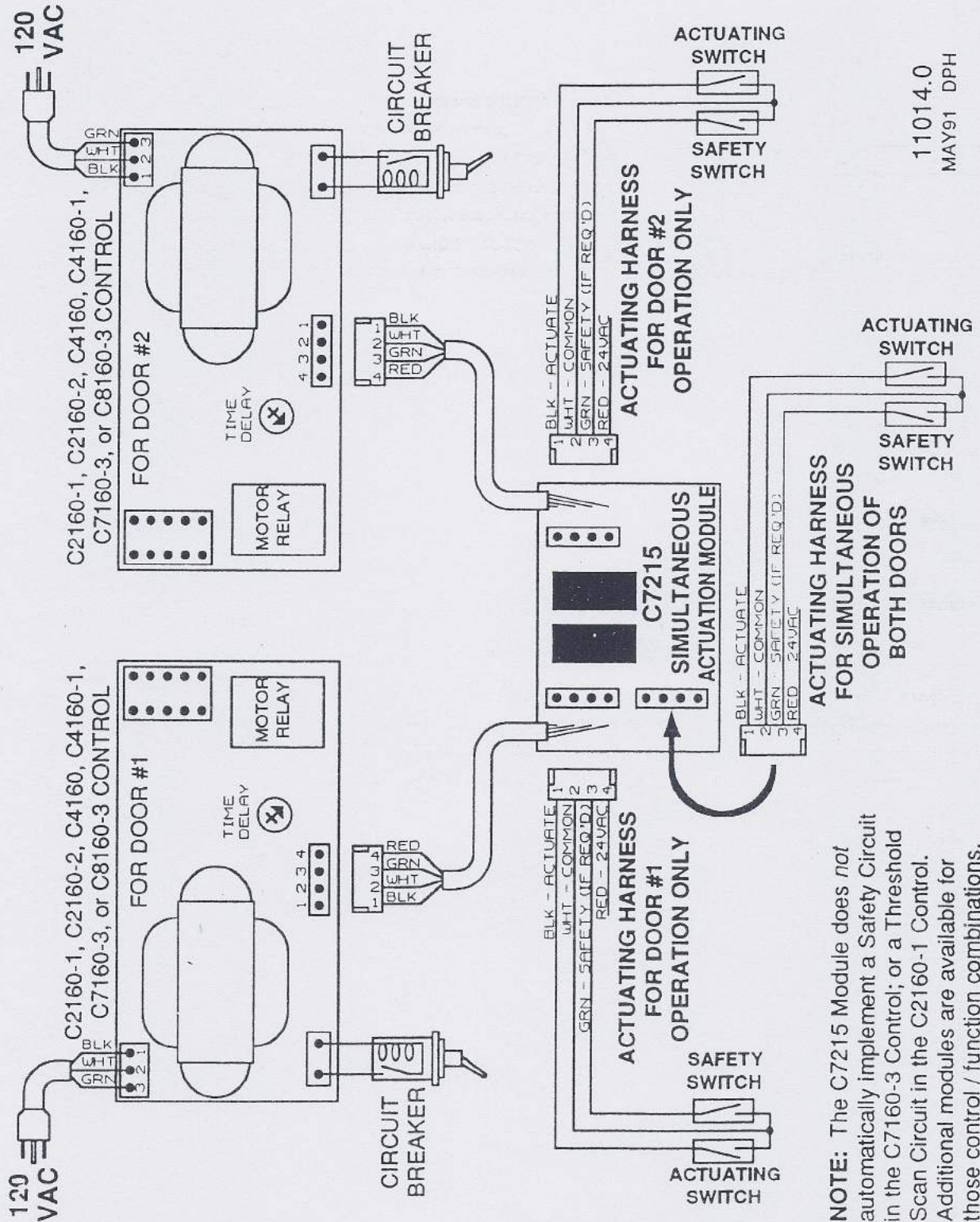

WIRING AND MODULE INFORMATION - CONT.

Fig. 40 - Description of C4150-1 Power Assist Close Module with Timing Sequences

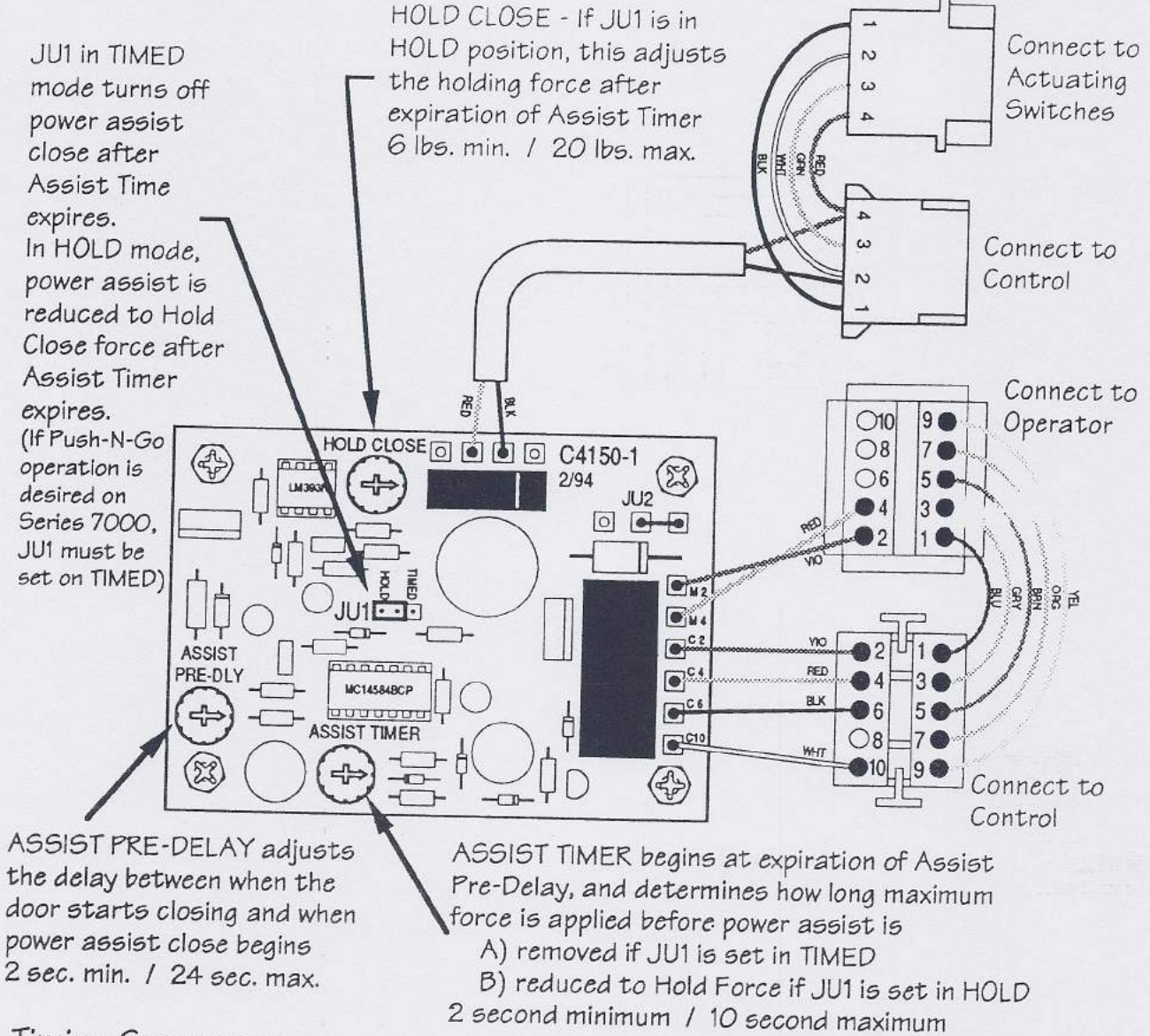

Timing Sequences:

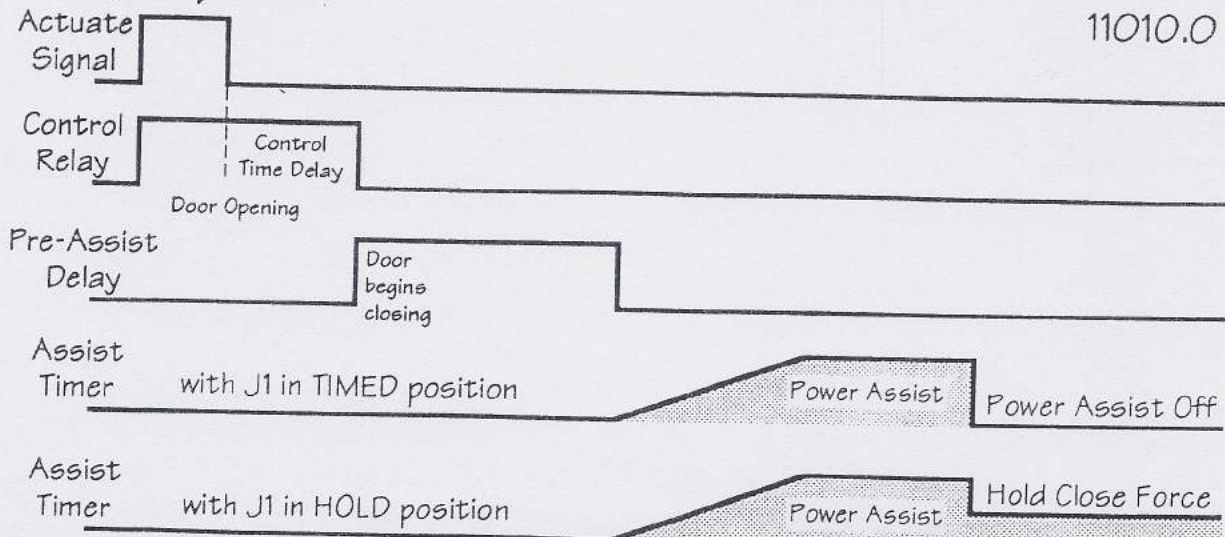

WIRING AND MODULE INFORMATION - CONT.

Fig. 41 - Series 4000 Wiring Schematic for C4150-1 Power Assist Close Module

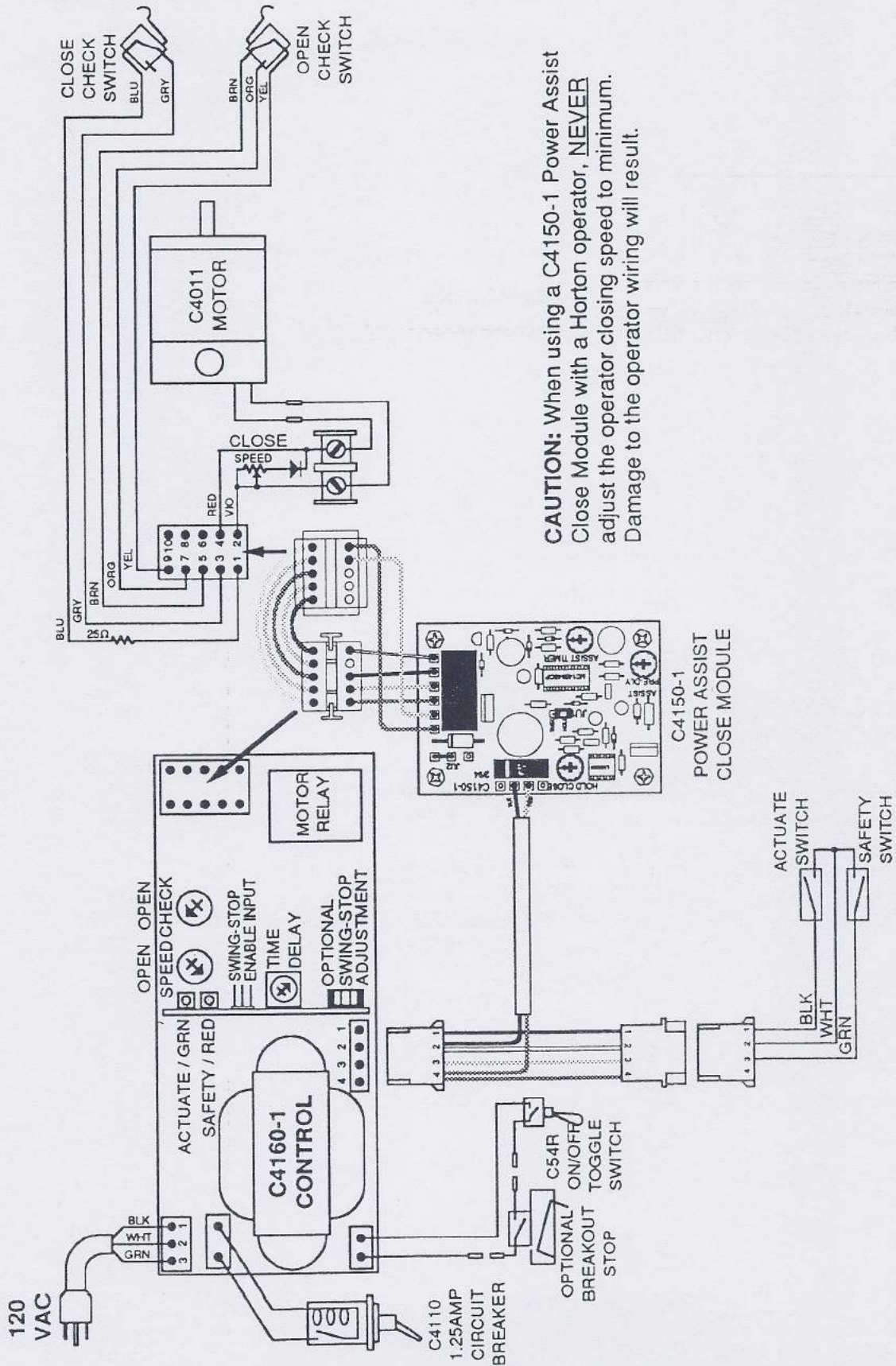

CAUTION: When using a C4150-1 Power Assist Close Module with a Horton operator, NEVER adjust the operator closing speed to minimum. Damage to the operator wiring will result.

WIRING AND MODULE INFORMATION - CONT.

Fig. 42 - C7220-1 Strike Interface Module Information

11015.0
APR94 DPH

CONTACTS RATED
10A @ 28VDC RESISTIVE

TO LOCK & LOCK POWER SUPPLY	TO DOOR CONTROL ACTUATE INPUT

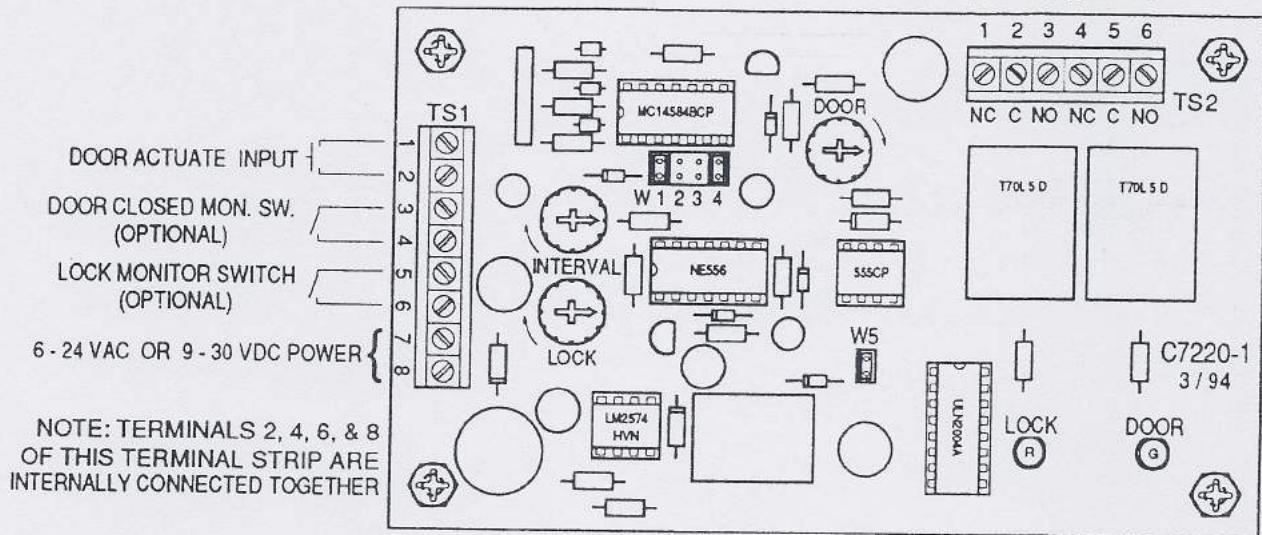

INTERVAL DELAY (1/4 - 3 SEC.) - ADJUSTS DELAY BETWEEN ACTUATION OF LOCK AND ACTUATION OF DOOR.

DOOR DELAY (1 - 29 SEC.) - ADJUSTS TIME DOOR WILL REMAIN ACTUATED AFTER RELEASE OF DOOR ACTUATE INPUT SIGNAL.

LOCK DELAY (1 - 14 SEC.) - ADJUSTS DELAY BETWEEN RELEASE OF DOOR ACTUATE SIGNAL AND RELEASE OF LOCK UNLOCK SIGNAL.

JUMPER STRAPS:

W1, 2, 3, 4 - DETERMINE USAGE OF DOOR POSITION AND LOCK POSITION MONITOR SWITCHES. WITH STRAPS IN W1 AND W4 (DEFAULT) NO EXTERNAL MONITOR SWITCHES ARE REQUIRED.

DOOR CLOSED MONITOR SWITCH - IF CONTACTS CLOSE WHEN DOOR IS OPEN, STRAP W4; IF CLOSED WHEN DOOR CLOSED, MOVE STRAP FROM W4 TO W3.

LOCK MONITOR SWITCH - IF CONTACTS CLOSE WHEN LOCK IS UNLOCKED, STRAP W1; IF CLOSED WHEN LOCK IS LOCKED, MOVE STRAP FROM W1 TO W2.

W5 - IF STRAP IS PRESENT, LOCK WILL REMAIN UNLOCKED FOR DURATION OF INTERVAL, DOOR, AND LOCK TIMERS. IF STRAP IS REMOVED, LOCK WILL REMAIN UNLOCKED FOR DURATION OF INTERVAL AND LOCK TIMERS ONLY; IT WILL BE RELEASED FOR BALANCE OF DOOR TIMER (USEFUL FOR NOISY LOCKS).

WIRING AND MODULE INFORMATION - CONT.

Fig. 43 - Typical Wiring Schematic for C7220-1 Strike Interface Module

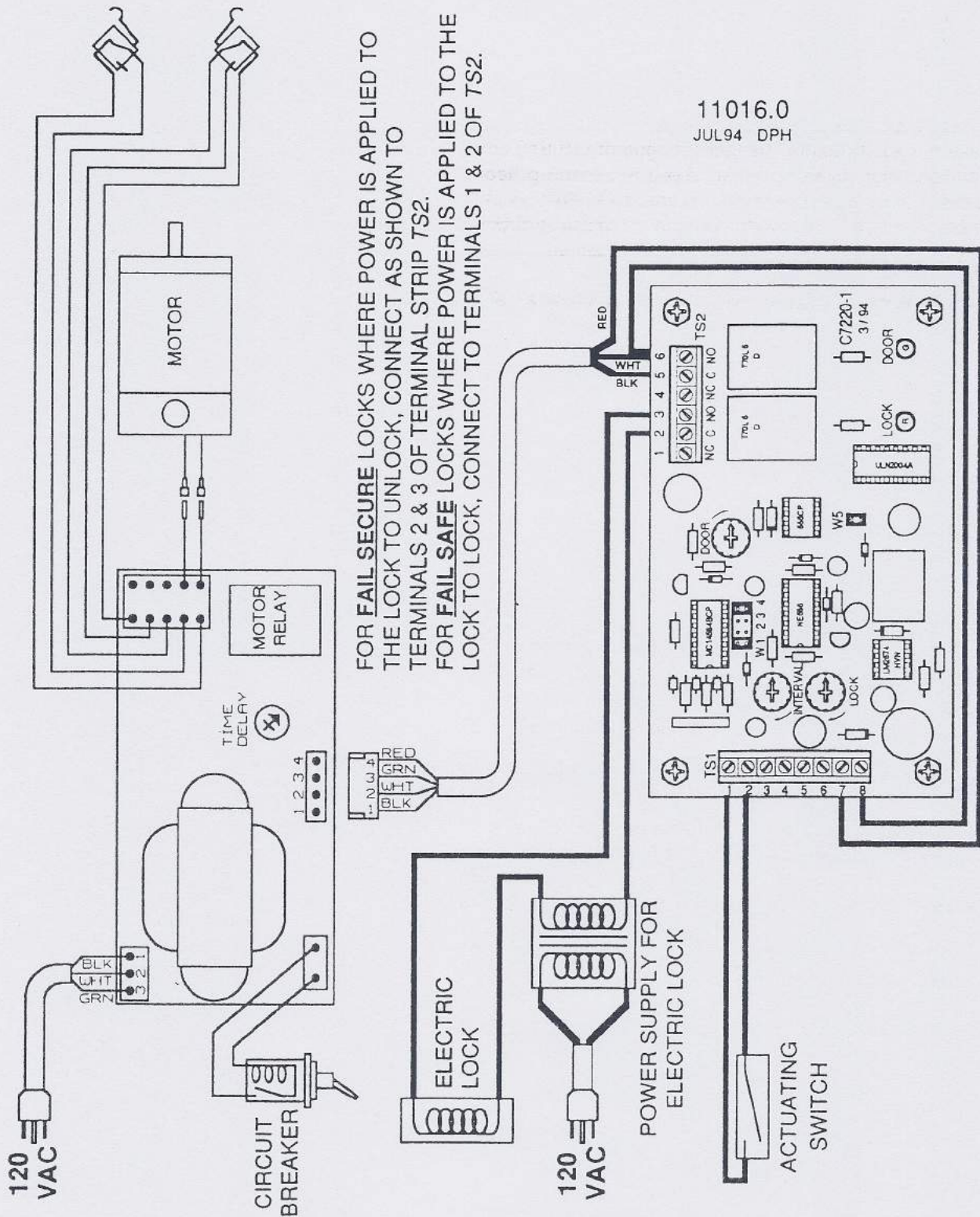

FOR FAIL SECURE LOCKS WHERE POWER IS APPLIED TO THE LOCK TO UNLOCK, CONNECT AS SHOWN TO TERMINALS 2 & 3 OF TERMINAL STRIP TS2.

FOR FAIL SAFE LOCKS WHERE POWER IS APPLIED TO THE LOCK TO LOCK, CONNECT TO TERMINALS 1 & 2 OF TS2.

11016.0
JUL94 DPH

15. ADJUSTING THE OPERATOR FOR CODE COMPLIANCE

The following important information is provided as a recommendation for safe operating speed adjustments and should be adhered to when installing or servicing the Series 4000.

A. Compliance with ANSI A156.10 - Normal Speed Operator

Opening Force : A power operated swing door shall not exert more than 40 pounds of force (180N) through the last 10° (back check), measured 1" (25) from the lock edge of the door.

Closing Force : A power operated swing door shall not exert more than 40 pounds of force (180N) at any point in the closing cycle, measured 1" (25) from the lock edge of the door.

Opening Speed : The opening speed of a power operated swing door to back check shall not be less than 1.5 seconds.

Note: Adjust C4160-1 at open speed. The acceleration potentiometer has been moved to the top of the circuit board for easier access. The acceleration potentiometer controls the rate by which the operator accelerates from initial start-up to the open speed that is currently set on the open speed potentiometer. Deceleration during the transition from open speed to open check is controlled by the deceleration potentiometer and should give a smoother operation in the checking action especially on short cycles.

Closing speed : The closing speed of a power operated swing door through the last 10° (latch check) shall be as follows (Maximum setting varies by door size and weight, speed shown assumes 1/4" glazing) -

36" (914) door and under, up to 100 lbs. (45 kg).....	2.0 seconds
36" (914) door, up to 140 lbs. (64 kg).....	2.3 seconds
42" (1067) door, up to 110 lbs. (50 kg).....	2.3 seconds
42" (1067) door, up to 150 lbs. (68 kg).....	2.7 seconds
48" (2119) door, up to 120 lbs (55 kg).....	2.8 seconds
48" (2119) door, up to 160 lbs (73 kg).....	3.2 seconds

Time Delay : After loss of actuating signal, minimum time delay shall be as follows -

Approach side using either sensors or mats.....	1 1/2 seconds
	2 seconds (Horton recommendation)
Swing / Safety side using either sensors or mats.....	4 seconds
Using "knowing act" momentary contact switches.....	5 seconds (Horton recommendation)

Note: Adjust to longer delay to suit traffic conditions and remote mounted activating switch locations .

B. Compliance with ANSI A156.19 - Low Energy, Slow Opening Operator

The door must be adjusted as follows if guide rails and safety sensors are not used :

Kinetic Energy : A low energy power operated swing door shall not exceed 1.25 foot-pounds (1.69 Nm).

Note: In order to meet this requirement the Series 4000 operator must be equipped with the C7160-3 control and the open and close speed to check must be adjusted to a minimum of 6 seconds

Closing and Opening Force : A low energy power operated swing door shall not exert more than 15 pounds of force (67N) at any point in the closing cycle, measured 1" (25) from the lock edge of the door.

Time Delay : After loss of actuating signal, minimum time delay shall be 5 seconds.

Note: Horton also recommends that a pushbutton or other "knowing act" device be used in activation.

ADJUSTING THE OPERATOR FOR CODE COMPLIANCE - CONT.

Fig. 44 - Series 4000 Wiring Schematic with C4160-1 Control

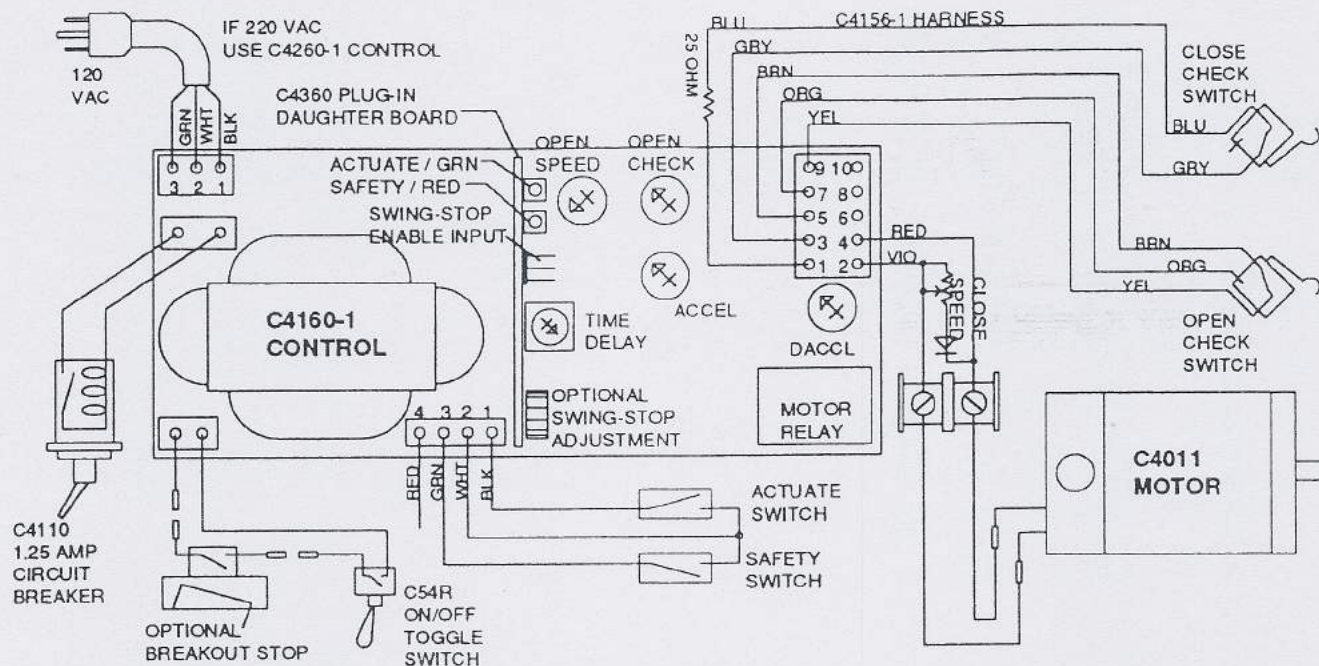

Note:
Wire Lace Not Shown For Clarity

Open Speed Adjustment:
Rotate Clockwise to Increase.

Open Check Speed
Adjustment: Rotate
Clockwise to Increase.

Open Acceleration Adjustment:
Rotate Clockwise to Increase.

C4156-1 Lace to Check
Switches and Motor Leads

120VAC Power-In
C4180 Power Cord
Assembly

To C4155
Circuit Breaker
Lace Assembly

C9026
Toggle Switch
Assembly

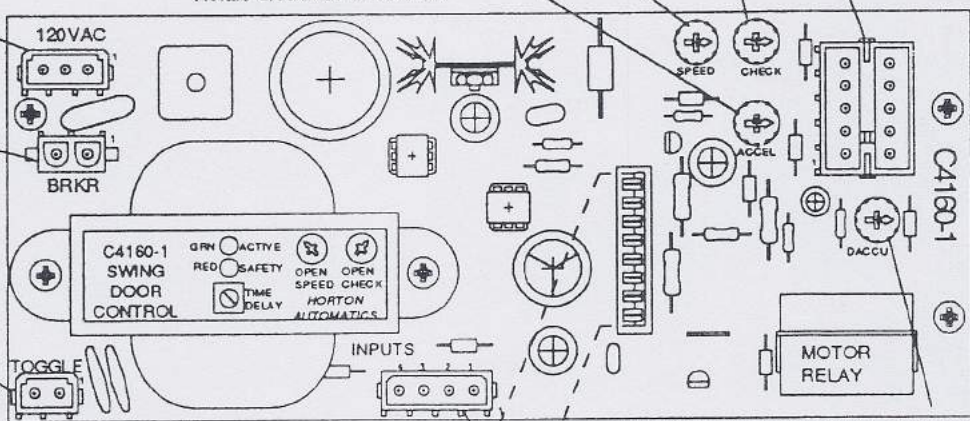

C4160-1 MASTER CONTROL BOARD

Open Deceleration Adjustment:
Rotate Clockwise to Increase.

Actuate Signal-
Green LED

Safety Signal-
Red LED

Swing Safe / Stop
Enable Input

Time Delay Adjustment:
Rotate Clockwise to
increase. Suggested Setting:
5 Seconds Minimum After
Full-Open.

Input Lace to Terminal Strip:
1- Actuate (ACT) , Blk
2- Common (COM) , Wht
3- Safety (SAF) , Grn
4- Not Used

Swing Safe / Stop Adjustment:
Rotate Clockwise to Increase.

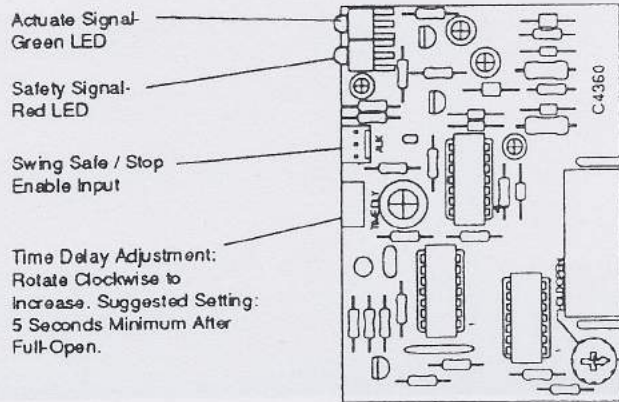

C4360 PLUG-IN DAUGHTER BOARD

ADJUSTING THE OPERATOR FOR CODE COMPLIANCE - CONT.

Fig. 45 - Series 4000 Operator w/lt C4160-1 Control

Note : Control Rotated for Clarity

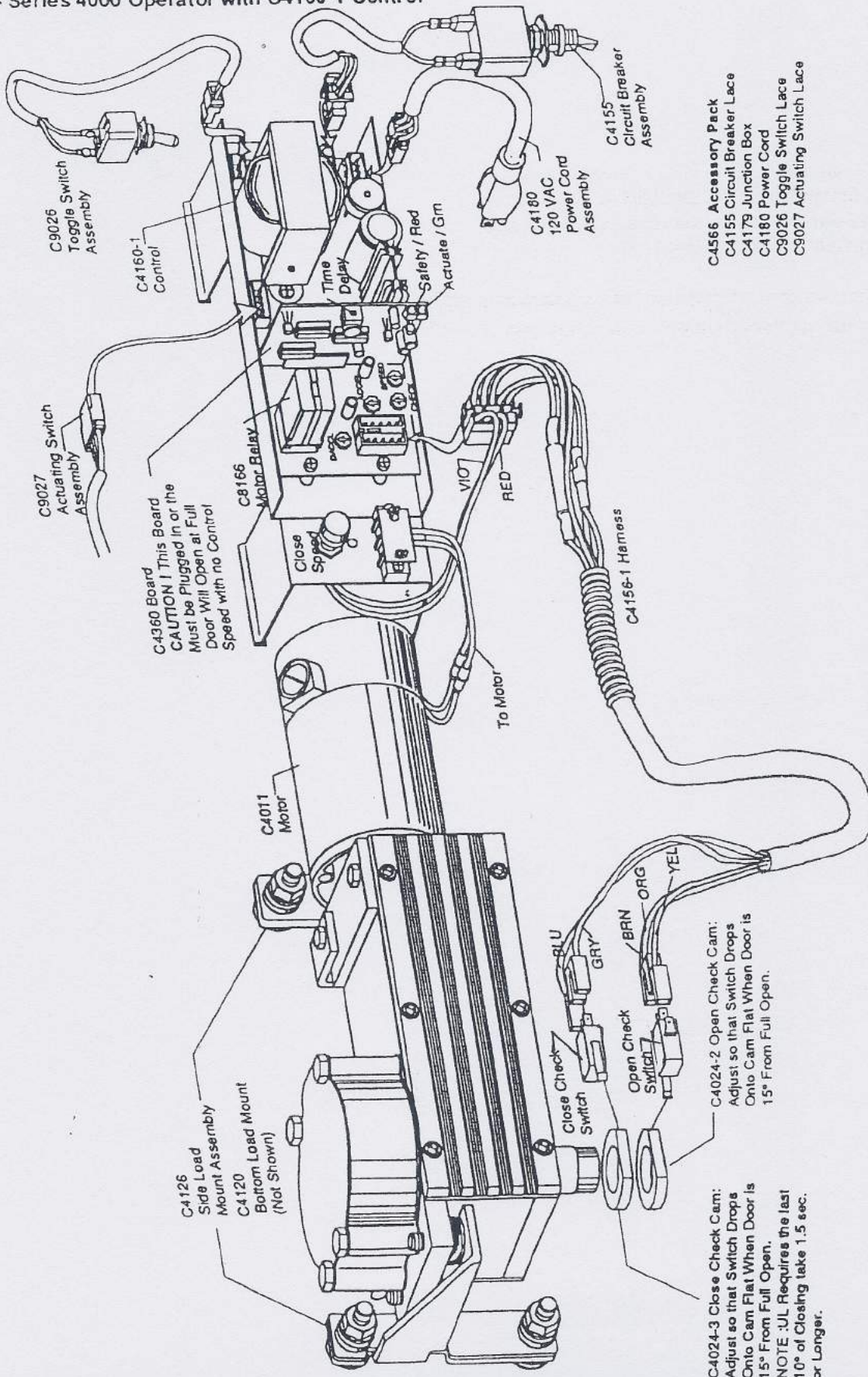

- C4566 Accessory Pack
- C4155 Circuit Breaker Lace
- C4179 Junction Box
- C4180 Power Cord
- C9026 Toggle Switch Lace
- C9027 Actuating Switch Lace

16. CHANGING OPERATOR HAND

In the event it is necessary to switch the hand of the operator (after verifying operator hand as per page G400.7), carefully follow these instructions.

A. Removal of Spring and Retainer

1. Clamp the operator in a vise with jaws against the side cover plates.
2. Remove two of the 1/2" HHMB bolts and loosen a third. Set the Horton Automatics spring removal tool or Rigid #2-24" strap wrench against the spring force. Hold the spring retainer in the correct position and remove the last two bolts. Allow the retainer to fully relax (1/2 turn).
3. Remove spring and retainer (leave tool on the retainer).

B. Adjustments and Reinstallation of Spring and Retainer

1. Rotate spring arbor (output shaft) as far as it will go in the opposite direction (240 degrees), using power arm for leverage if necessary. Turn spring retainer and spring over and place on notched arbor approximately 1/2 turn away from proper location (proper location is where bolt pattern matches).
2. Preload the spring assembly by rotating it 1/2 turn, install cover and tighten all bolts.
3. Wire motor correctly for new hand as shown in Fig. 3 on page G400.7.
4. After reinstalling in header, adjust check cams as necessary for proper operation (See Fig. 45 on previous page).

Fig. 46 - Changing Operator Hand (Top Views)

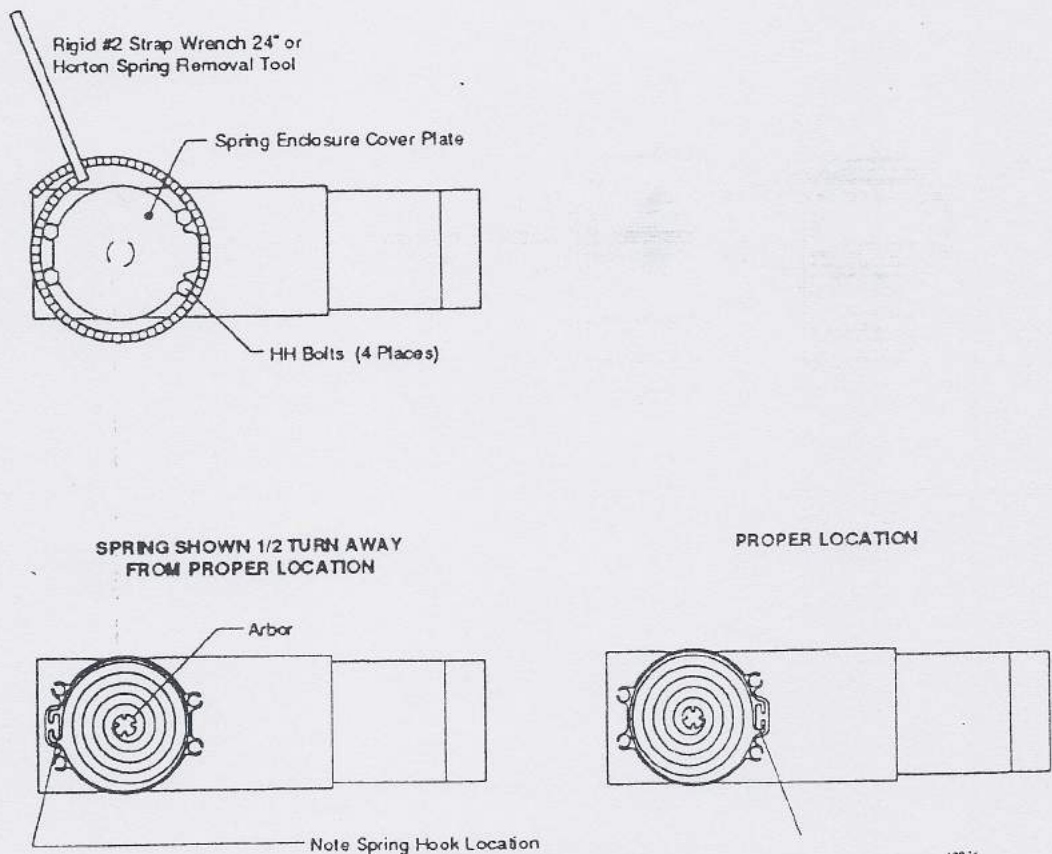

17. APPLICATION OF SAFETY DECALS (Per ANSI Specifications)

Safety decals for all automatic doors play an important role in protecting the owner against product liability and providing the user with safety signage as outlined in ANSI/BHMA A156.10- 1991 *American National Standard for Power Operated Pedestrian Doors*. Several safety decals are provided in the Installation Instructions and Owner's Manual envelope with each Swing Door door unit. The installer should adhere these decals to the door unit as instructed and illustrated in Figure 46 below.

A. C1633-2 Safety Decal for Two-Way Traffic

Two C1633-2 yellow decals with the words "Caution- Automatic Door" and Two-Way Traffic" on both sides are provided with each pair unit. Adhere these decals to both panels on a centerline of 58" (1473) plus or minus 5" (127).

B. C1631-2 Safety Decal for One-Way Traffic

Two C1631-2 decals with a black arrow circumscribed with a green border and the words "Automatic Door- Keep Moving" on one side and a red circle and the words "Do Not Enter" and "Stand Clear Automatic Door Can Swing Open At Any Time" on the opposite side are provided with each pair unit. Adhere these decals to both panels on a centerline of 58" (1473) plus or minus 5" (127).

C. C1690-2 Daily Safety Check Decal

One C1690 rectangular decal is provided to give the owners instructions for checking the operation of their automatic door unit on a daily basis. Adhere this decal to the interior face of the jamb just below the header.

Fig. 47- Safety Decal Placement on Series 4000 Swing Doors

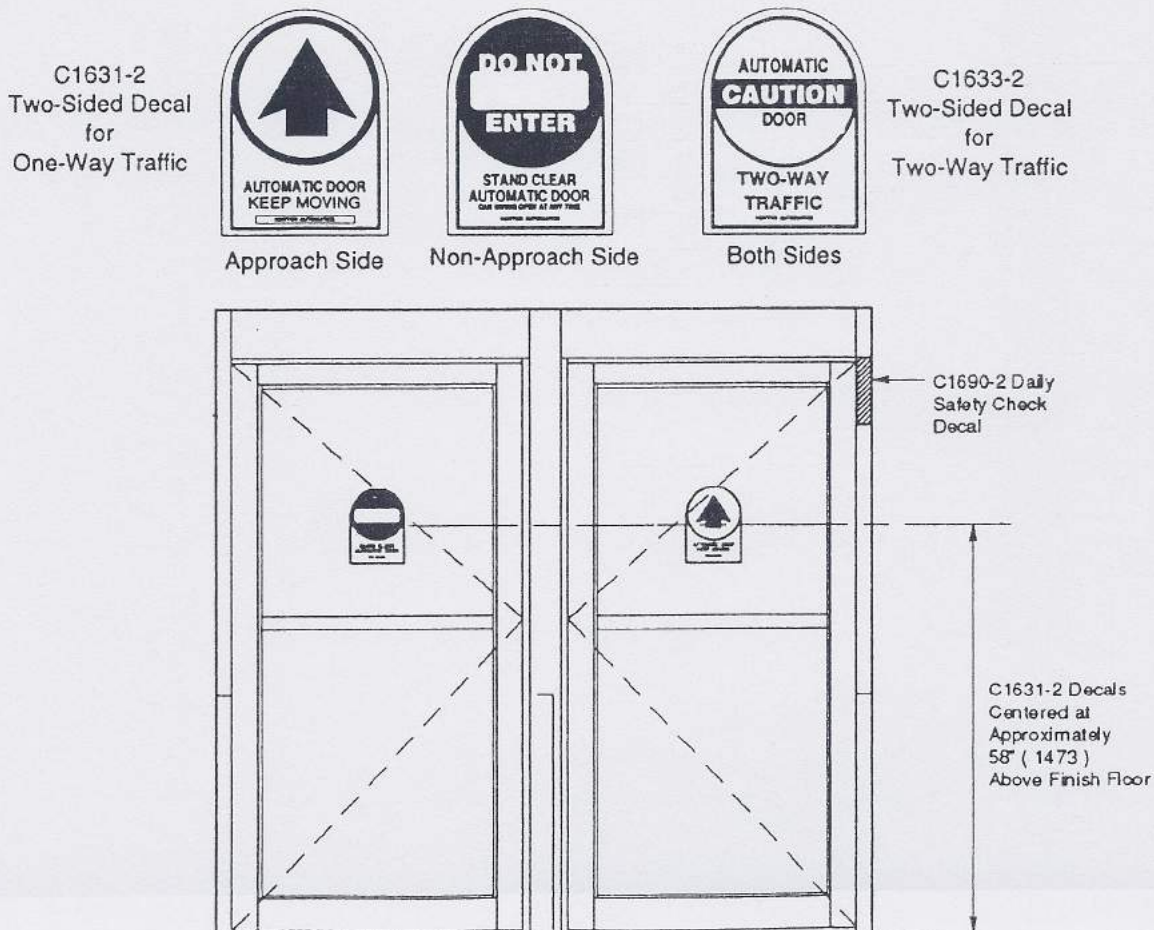

18. PARTS, ASSEMBLIES AND SUB-ASSEMBLIES

Chart 5 - Series 4000 Parts List

ITEM	PART #	DESCRIPTION	QTY	ITEM	PART #	DESCRIPTION	QTY
1	C4083-2	Side Plate	2	47	C4053	Upper Spring Cover Plate	1
2	C4036	Gasket	2	48	C4051-1	Closing Spring	1
3	C416	Screw 1/4-20 x 3" FHMS	2	49	C4054	Lower Spring Cover Plate	1
4	C4030-1	Upper Bearing Plate	1	50	C4029-1	Spring Mounting Collar	1
5	C7062	Bearing 3/4"ID x 1-5/8"OD	1	51	C9027-3	Control Actuating Harn. Assy	1
6	C4119-1	3rd Transfer Shaft Assy	1	52	C4160-1	Master Control Assy	1
7	C4020-1	Output Shaft Assy	1	53	C4360	Sub Timer Control Assy	1
8	C4088	Bearing 1"ID x 2"OD	1	54	C9026	On/Off Toggle Lace Assy	1
9	C4087	Shaft Seal	1	55	C4155	Circuit Breaker Lace Assy	1
10	C4037	Plate Mounted Stop	1	56	C4180	120V AC Power Cord Assy	1
11	C4043	Gear Train Endcap	1	57	C4179	Junction Box Assy	1
12	C4074	Screw 3/8-16 x 1 1/4"HHMB	2	58	C4156-1	Operator Wire Harness Assy	1
13	C4085	Spacer Washer	2	59	C4120	Gear Train Mnt. Bkt. Assy	1
14	C9655	Nut 3/8-16	4	60	C4013	Bkt. Oper. Motor Support	1
15	C4141	Bracket, Spring End	1	61	C4025	Nylon Insert	2
16	C4080	Isolation Mount	4	62	C4079	Plate Gear Train Nylon Supt	1
17	C4078	Washer 7/16"ID x 1"OD	4	63	C4080	Mount- Rubber	2
18	C4145	Screw 3/8-16 x 1 3/4"SQHB	4	64	C5254-1	Connecting Arm Assy	1
19	C9543	Screw 5/16-18 x 1"SCS	2	65	C4250	Inswing Arm	1
20	C4024-3	Back Check Switch Cam	1	66	C4252	Outswing Arm	1
21	C1519	Screw #4-40 BHMS	4	67	C4530	Direct Drive Arm	1
22	C2106-1	Microswitch	2	68	C4551-1	A/B Arm Assembly	1
23	C4076-2	Spacer for Switch	1	69	C4550	Track Assembly	1
24	C4024-2	Latch Check Switch Cam	1	70	C4556	Dr Block & Bushing Sub Assy	1
25	C4042	Shim for Switch Cams	1	71	C4248-1	B/O Para. Arm Sub Assy	1
26	4032-1	Lower Bearing Plate	1	72	C4241-1	B/O Para Arm & Trk Assy	1
27	C4031	Bearing Plate Spacer	2	73	C4244-1	Non-B/O Para Arm Sub Assy	1
28	C4071	Screw 1/4-20 x 3/8"SCS	12	74	C4240-1	Non-B/O Para Arm & Trk Assy	1
29	C4112-1	2nd Transfer Shaft Assy	1	75	C9535	Top Pivot Assy Door Portion	1
30	C4111-1	1st Transfer Shaft Assy	1	76	C4538	Top Pivot Assy Btm Load	1
31	C4061	Bearing 3/8"ID x 1-1/8"OD	6	77	C4537	Pin Assy Top Pivot Btm Load	1
32	C4059	Screw 1/4-20 x 3 1/2"HHMB	2	78	C4548	Top Pivot Assy Side Load	1
33	C422	1/8"Dia x 1/2" Roll Pin	2	79	C4547	Pin Assy Top Pivot Side Load	1
34	C4026	Motor Mounting Plate	1	80	C4542	Btm Pivot Assy Thresh w/Mat	1
35	C879R	Screw 1/4"-20 x 3/4"FHSCS	3	81	C9541	Pivot Assy Door Portion	1
36	C405	Screw 1/4"-20 x 5/8"SCS	2	82	C5542-1	Pivot Assy Floor Portion	1
37	C4014	Spiral Bevel Gear	1	83	C5595	Btm Pivot Assy Non Thresh.	1
38	C4011	Motor	1	84	C5598	Pivot Assy Door Portion	1
39	C404	Nut 1/4-20	1	85	C5552-1	Bolt Threshold Pivot	1
40	C4144	Bracket, Secondary	1	86	C7609	Pivot Assy Dr Portion D.Drive	1
41	C554	Lock Washer 3/8"	8	87	C7610	Pivot Assy Flr Portion D Drive	1
42	C4142	Bracket, Motor End	1	88	C7606	Pivot Assy D.Drive	1
43	C5521	Lock Washer 5/16"	2	89	C7614	Btm Pivot Flr Portion D.Drive	1
44	C4056	Screw 5/16-18 x 1/2"HHMB	2	90	C5241A	#14 x 1 1/2 FHMS	2
45	C4058-1	Screw 1/4"-20 x 4" HHMB	1	91	C1424	#14 Blue Plastic Anchor	2
46	C5265-1	Screw 5/16-18 x 2"HHMB	4				

PARTS, ASSEMBLIES AND SUB-ASSEMBLIES - CONT.

Fig. 48 - Exploded View of Series 4000 Operator

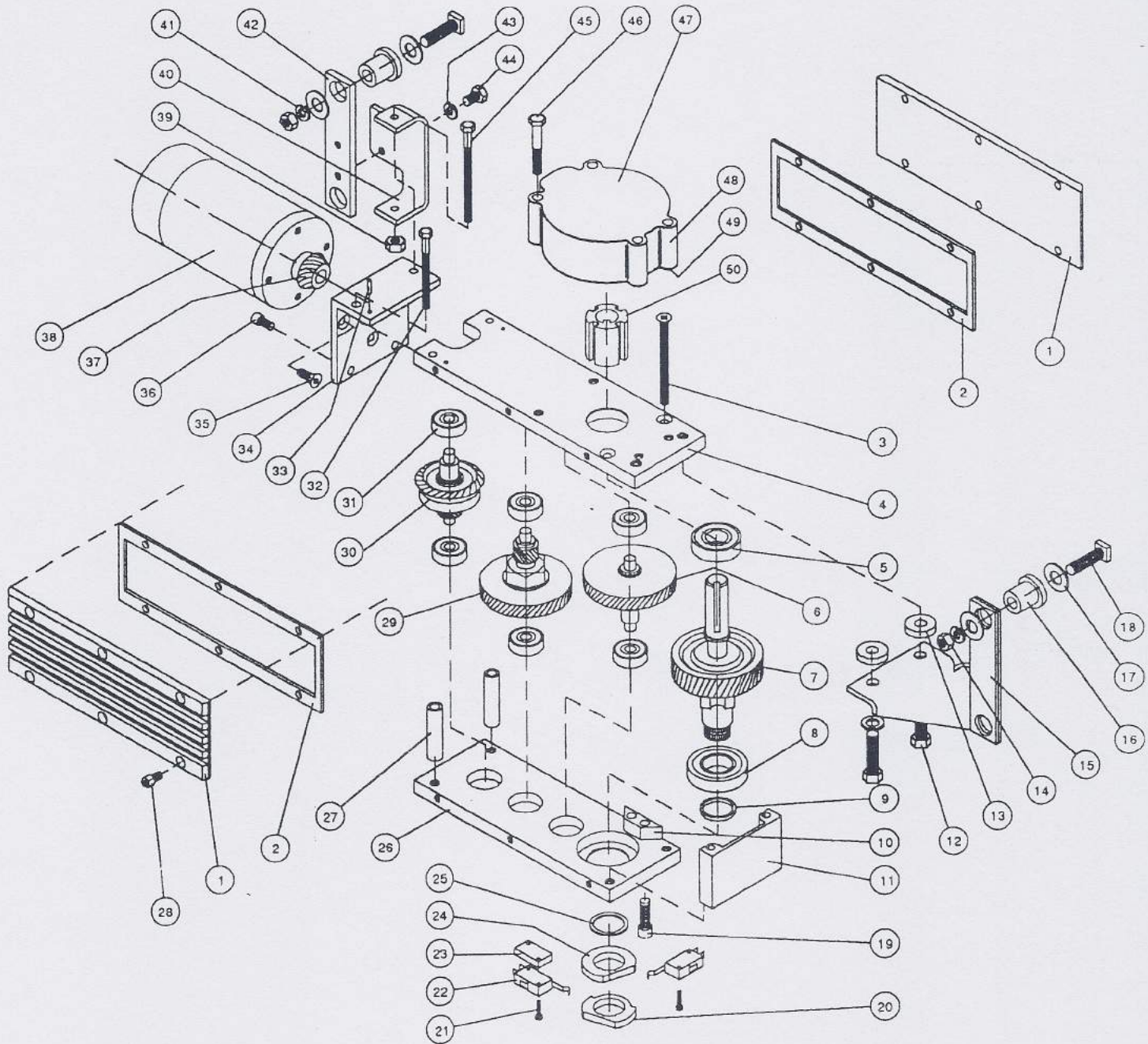

PARTS, ASSEMBLIES AND SUB-ASSEMBLIES - CONT.

Fig. 49 - Series 4000 Master Control Assembly, Lace Assemblies and Operator Mounting Bracket

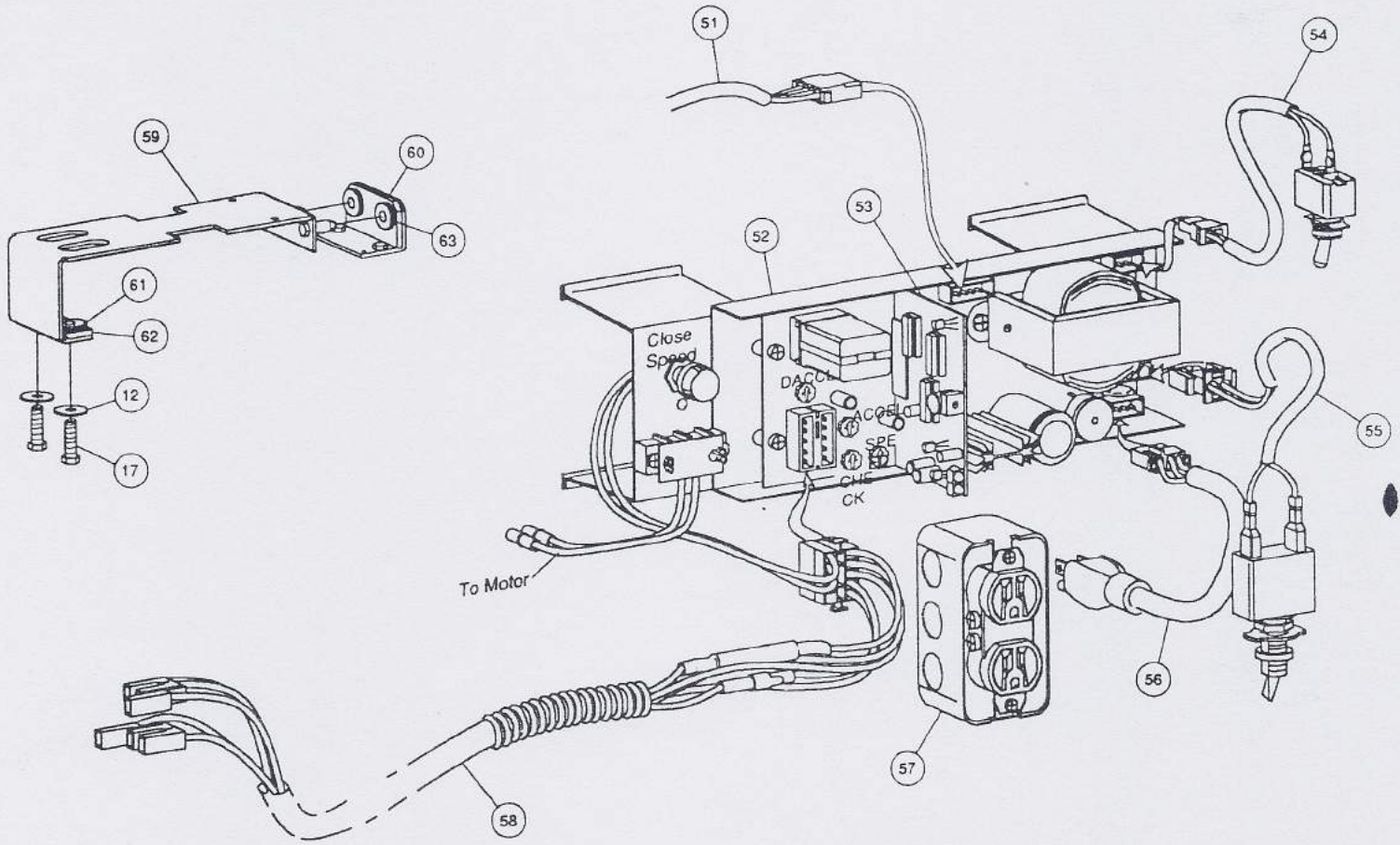

PARTS, ASSEMBLIES AND SUB-ASSEMBLIES - CONT.

Fig. 50 - Arm Assemblies and Sub-Assemblies

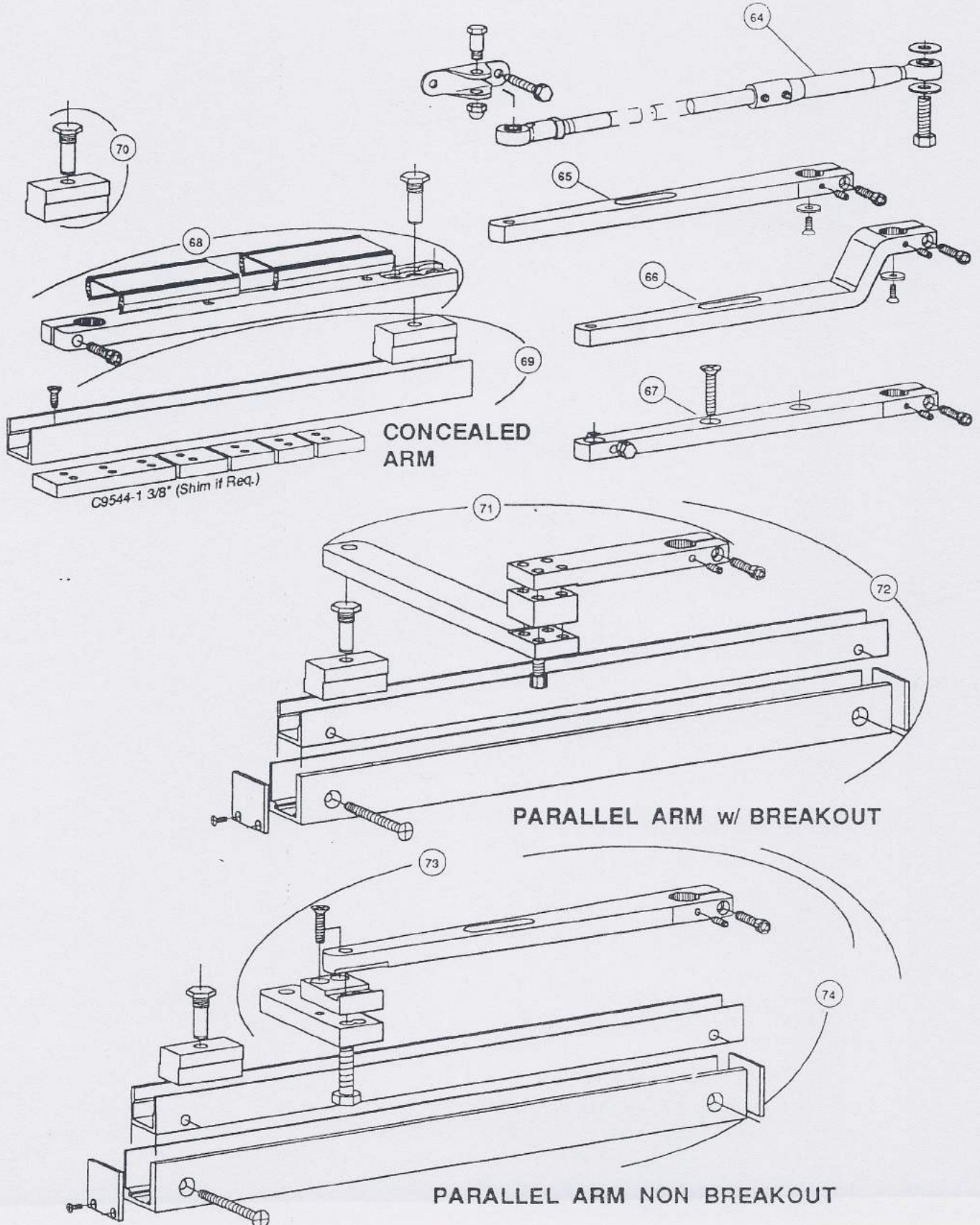

PARTS, ASSEMBLIES AND SUB-ASSEMBLIES - CONT.

Fig. 51 - Series 4000 Top and Bottom Pivot Assemblies and Sub-Assemblies

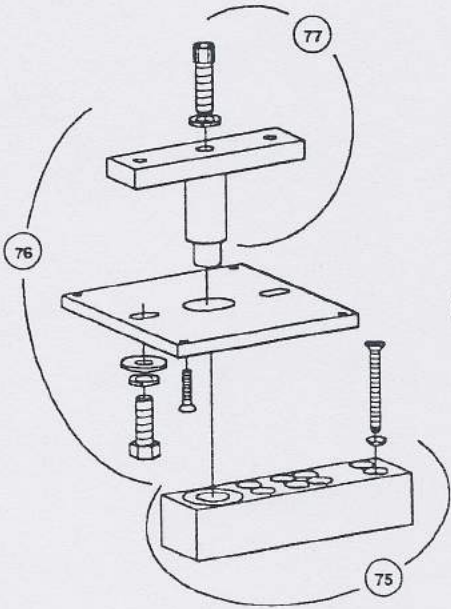

4500, 4800 TOP PIVOT
BOTTOM LOAD

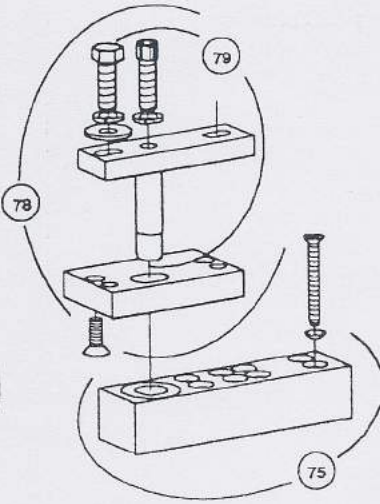

4500, 4800 TOP PIVOT
SIDE LOAD SWING DOOR

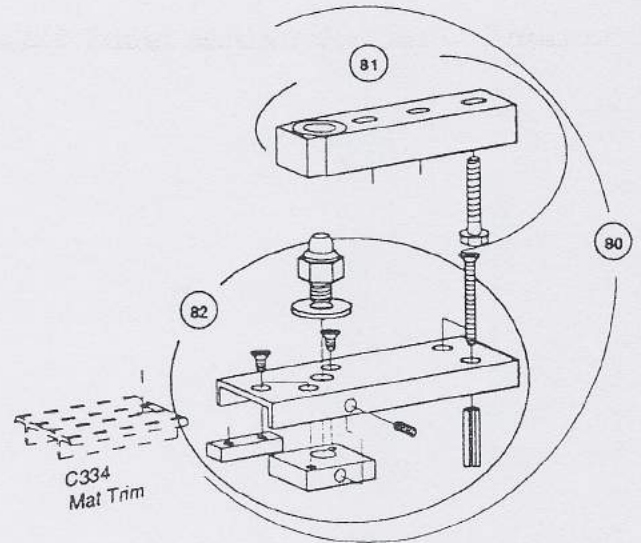

SWING DOOR
THRESHOLD PIVOT w/ MATS

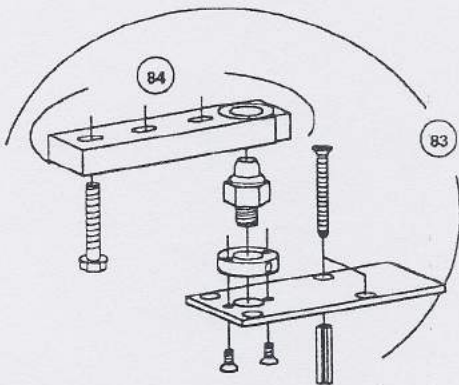

SWING DOOR
NON THRESHOLD PIVOT

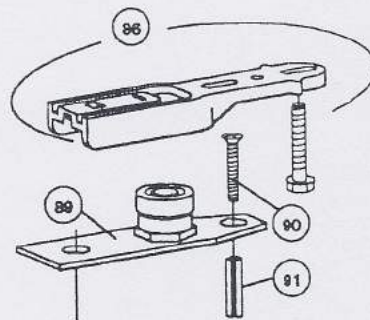

DIRECT DRIVE SWING DOOR
NON THRESHOLD PIVOT

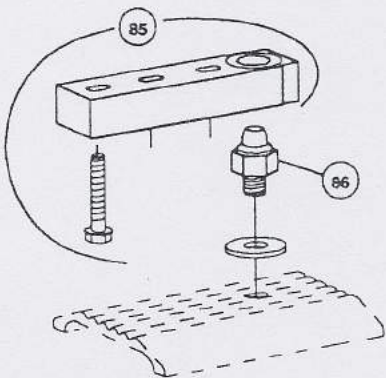

SWING DOOR
THRESHOLD PIVOT

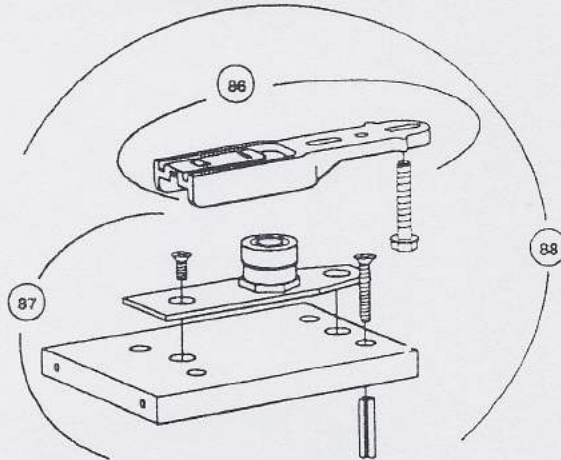

DIRECT DRIVE SWING DOOR
THRESHOLD PIVOT



Horton Automatics
 A Division of Overhead Door Corporation
 4242 Baldwin Blvd.
 Corpus Christi, Texas 78405

SB

SERVICE BULLETIN

BY: John Cringole

TO: **Horton Distributors**

BULLETIN NO: **SB95-6**

DATE: **4-20-95**

SUBJECT: C4360 Timer Module for C4160-1 Master Control

Recently Horton Automatics announced the release of a new swing door safety and activation system -- the Series 1885 Swing Scan II and IIe.

The **Swing Safe/Swing Stop Feature** of this new system requires a C4160-1 Master Control with a current C4360 Plug-in Daughter Board (shown in the detail below). The C4360 board includes **Swing Safe/Stop Enable Input** and **Swing Safe/Stop Adjustment**.

This C4360 plug-in Daughter Board has been standard on production C4160-1 Master Controls since early 1994.

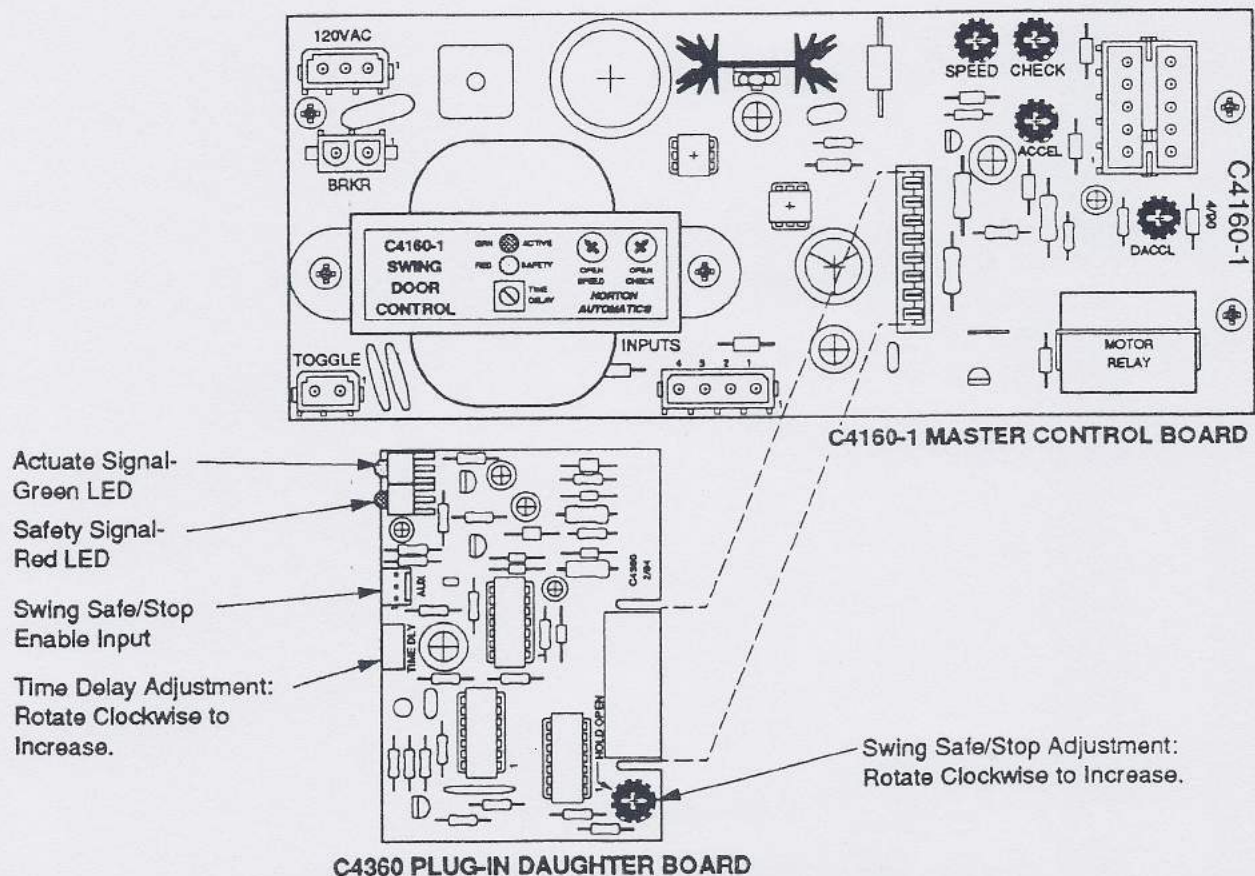

Actuate Signal-
Green LED

Safety Signal-
Red LED

Swing Safe/Stop
Enable Input

Time Delay Adjustment:
Rotate Clockwise to
Increase.

Swing Safe/Stop Adjustment:
Rotate Clockwise to Increase.

C4360 PLUG-IN DAUGHTER BOARD

C4160-1 MASTER CONTROL BOARD

