

# ESA II CONTROLLER AND WIRING MANUAL

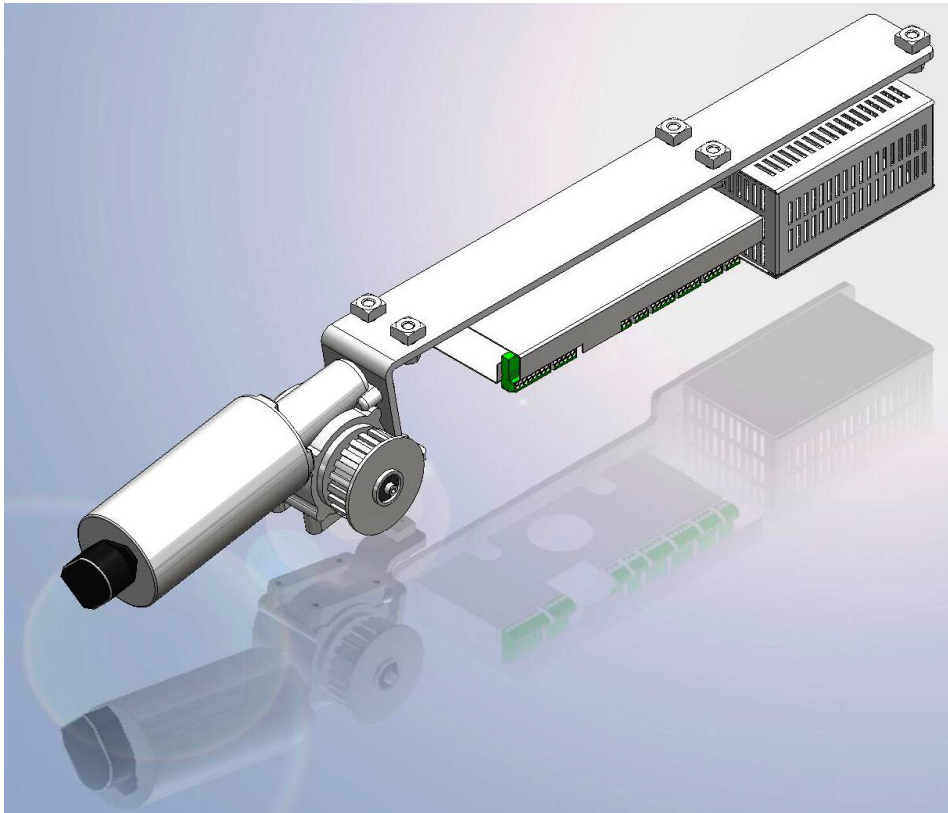

## Contents

	Page
Contents	1
Technical data	2
Commissioning	3
Settings	4
Function test	4 - 5
Function module	5 - 6
Care and maintenance	6 - 7
Operation instructions	7 - 8
Troubleshooting	9
Terminal definitions:	10 - 12
Wiring diagrams:	
General arrangement	13
Motor, control system and power supply	14
Night-/Bank-open	14
2 safety beams Microcell THREE (BEA)	15
Without safety beam	15
Breakout/cutoff switch	16
Without breakout/cutoff switch	16
Battery	17
Program switch	17
Motion detector / presence sensor (BEA)	18
Motion detector / presence sensor profusion (Bircher Reglomat)	19
Panic closing function	20
Electric lock	21
Airlock	22
Parameterising	23 - 29

## Technical Data

Power supply data	120 V +/- 10% 50/60 Hz
Fuse	6.6 A not exchangeable
Power supply for external accessories	27 V DC / 2 A
Power consumption: max.	250 W

Function programs	· = yes
Close	·
AUTOMATIC	·
PERMANENT OPENING	·
PARTIAL OPENING	·
EXIT	•

Parameter	setting range	
	min.	max.
Opening speed	4 in./s	30 in./s
Closing speed (up to 190 lb)	4 in./s	12 in./s
Creep speed OPENING	1 in./s	4 in./s
Creep speed CLOSING	1 in./s	4 in./s
Brake ramp OPEN braking deceleration OPEN	1	9
Brake ramp CLOSE	1	9
Brake ramp reversing	1	9
Hold open time	1.5 s	180 s
Hold open time NIGHT/BANK	1.5 s	60 s
Delayed opening NIGHT/BANK	0 s	10 s
Partial Opening	10 inch	open
Creep speed distance OPENING	0 inch	12 inch
Creep speed distance CLOSING	0 inch	12 inch
Acceleration OPENING	1	9
Acceleration CLOSING	1	9
Force limitation OPENING	11 lb	70 lb
Force limitation CLOSING	11 lb	70 lb

## 1. Commissioning

### 1.1 Please note:

Work on electrical equipment may only be performed by properly qualified electricians. Power supply (by others) with 15 A fuse protection must be available.

Power cord must be double-insulated, for example: Do not use ribbon cable! The maximum cable length of the external components must not exceed 98 ft.

### 1.2 Basic requirements:

- The operator is fully assembled.
- The protective earth is connected.
- The safety beams are connected (optional).
- The rechargeable battery pack (optional) is connected.
- Components supplied separately, such as program panel, activators, radar motion detectors, Night-/Bank key switches and connected.
- The end stops are adjusted so that, at maximum opening with, both active leaves are in contact with the stops; and when door is closed, neither panel touches the sealing profile.
- The door has to run smoothly.

### 1.3 Commissioning

1. Open the sliding leaves half way.
2. Move the program switch to position CLOSE
3. Insure jumper is in place on the breakout or emergency stop contacts



The door must perform a closing cycle at low (creep) speed.

If the door performs an opening cycle, the system must be set back to original settings. Disconnect the power plug so that the opening cycle stops.

Proceed on 1.5 original settings

If the door performs a closing cycle, proceed with the learning cycle starting with the door closed.

### Please note:

The safety beams and radar motion detectors are disabled during the learning cycle, as it has to be performed without interruptions.

In case that a fault or error should occur during this procedure, the learning cycle will be interrupted needs to be re-started.

### 1.4 Performing the learning cycle:

Press SERVICE/SELECT button until one of the external until each one of the display illuminates in turn.

- The door accelerates in order to determine the door weight.
- The door opens at low (creep) speed to determine the opening width.
- The opening parameters are now stored and an 8 flashes twice on the 7-segment display.

The learning cycle is now complete.

- The 7-segment display indicates a dot.
- The door closes at normal speed.

### Test of opening cycle

Set program switch to AUTOMATIC and push the SERVICE/SELECT button

- The door performs an opening cycle and is closed after the hold-open time expires.

The following door parameters must be checked and amended if required.

Settings: See operating instructions of adjustment.

Perform amendments with the aid of the parameterization instructions and the 7-segment display on the control unit or via PDA.

### Menu A.:

Emergency operation (via rechargeable battery pack)  
- original settings = 0

### Menu r.:

Locking action depending on position of program switch  
- original settings = 1

### Menu L.:

Locking type original settings = 1

The locking type is not learned automatically during the learning cycle.

### 1.5 General information concerning the original settings.

If several settings have been changed, the door no longer works properly, reset to original settings

- Set program switch to CLOSE
- Open the door leaves to 50%
- Connect power plug.
- Press and hold the service key.
- As soon as the power supply has been switched on, the control unit powers up and the security checks are performed.  
An 8 is shown on the seven-segment display. When the 8 blinks twice, the original settings have been restored.
- In case the door starts an opening cycle, press the minus button on the control unit to change the direction of the motor.
- Following the restoring of the original settings, differing settings (e.g. locking type) have to be made manually either via the buttons on the control unit or via the PDA (parameterization) and a learning cycle has to be performed (see 1.4)

## 2. Settings

The control unit is preset, i.e. If you require another setting, you will have to implement this either with the aid of the buttons of the 7-segment display on the control unit (see adjustment instructions), or via the PDA.

## 3. Function test

Please note:

All connected sensors must be checked in every program switch position.

The sensors must be set according to the respective installation instructions/documentation texts.

### 3.1 Safety beams (Optional-not required)

Automatic safety beam self-check  
(internal test via control unit)

The safety beams are automatically tested before each closing cycle. If the test fails (the door does not close) the system must be checked by a service engineer.

The passage between the sliding leaves is monitored by safety beams. If a person or an object enters the passage or detection range of the safety beams, a closing cycle is reversed to an opening cycle and the door remains open until the monitored area is free and the hold-open time has expired.

Manual safety beam check...

During closing cycle:

Interrupt one safety beam after the other during the closing cycle.

- The respective LED on the control unit goes out and the door reverses.

While the door is open:

Interrupt the safety beams for several seconds while the door is open.

- The door should remain open for as long as the safety beams are interrupted.
- Once the safety beams are uninterrupted, the door should close on expiry of the preset hold-open time.

### 3.2 External activation sensor

Activation sensors are mostly radar sensors responding to movements. The system is activated by approaching people or objects.

Function test.

Basic requirements:

The external activation sensor is connected and the program switch is set to AUTOMATIC or PARTIAL OPEN position.

Function:

If a person or an object affects the range of the sensor, the door opens, and then closes on expiry of the hold-open time.

### 3.3 Internal activation sensor

Function test.

Basic requirements:

The internal activation sensor must be connected and the program switch must be set to AUTOMATIC, EXIT ONLY or PARTIAL OPEN position.

Function:

If a person or an object affects the detection range of the sensor, the door opens, and then closes on expiry of the hold-open time.

### 3.4 Night-/ Bank Function

Function test.

Basic requirements:

The Night-/ Bank contact is connected and the program switch is set to CLOSE.

Function:

Activate the system with the Night-/ Bank contact.

- The door is unlocked and opens.
- Once the user has passed the door or on expiry of a fixed hold-open time, the door closes and locks in the closed position.

### 3.5 Breakout Switch

Function test.

Basic requirements:

The program switch must be set to AUTOMATIC, PARTIAL OPEN, EXIT ONLY, CLOSE (not locked) or PERMANENT OPEN.

Function:

Breakout any panel.

- The door leaves stop immediately
- The door can be moved manually.

### 3.6 Locking device

The door is in close position, it is locked, when the program switch is set to OFF, AUTOMATIC or EXIT ONLY.

### 3.7 Monitoring of closing and opening force

Obstruction during closing cycle:

If the door leaves run up against an obstruction during the closing cycle, the closing cycle is reversed into an opening cycle. The door opens to its full width. The door then closes at low (creep) speed until the hold open time expires. This sequence is repeated until the obstruction is removed.

Obstruction during opening cycle:

If the door leaves open against an obstruction, the door stops, then performs a further opening attempt at low (creep) speed. If the obstruction is still present, the door stops again. After a total of six opening attempts the door closes. Once the obstruction is removed, the next opening cycle is performed at low (creep) speed. Then the door resumes operation at the preset speed.

### 3.8 EMERGENCY OPEN FUNCTION in the event of a power failure

#### Basic requirements:

The rechargeable battery pack (optional) is connected and the EMERGENCY OPEN FUNCTION is set.

#### In the event of a power failure:

If the program switch is in CLOSE position:

- The door remains closed.

If the program switch is in AUTOMATIC, PARTIAL OPEN or EXIT ONLY position:

- An automatic emergency opening is performed.
- The door is opened with the aid of the rechargeable battery pack (optional).

The door may be manually unlocked and opened from the inside.

### 3.9 EMERGENCY CLOSING in the event of a power failure

#### Basic requirements:

The rechargeable battery pack (optional) is connected and the EMERGENCY CLOSING FUNCTION is set.

#### Function:

Set the program switch to AUTOMATIC, EXIT ONLY, PARTIAL OPEN or PERMANENT OPEN position.

The door is in open position.

Remove the power plug (power failure).

- The door performs a complete closing cycle with the aid of the rechargeable battery pack.

### 3.10 EMERGENCY OPERATION in the event of a power failure.

#### Basic requirements:

The EMERGENCY OPERATION FUNCTION is set and the rechargeable battery pack (optional) is connected.

#### Function:

As soon as the system is activated the sliding leaves move at low (creep) speed.

Furthermore all functions remain operational until the rechargeable battery pack (optional) is empty.

### 3.11 Safeguarding of door:

The safety measures to safeguard the doors must be made in accordance with the local (country-specific) regulations.

## 4. Function module

Additional functions may be set/selected with the aid of the function module.

The following additional functions are available:

- Securing the closing edges
- Panic Closing Function
- Door status contacts
- Airlock Function

The functions may be connected via two different DCW address.

## DCW address 48



The system must be disconnected from power supply while the DCW address of the function module is set.

#### Setting the DCW address:

Set both DIP switches of the function module to CLOSE position.

The DCW address 48 is now set.

#### 4.1 Securing the secondary closing edges with the "DCW address 48" (IN 1 and IN 2) (See connection diagram of function module.)

Presence sensors monitor the side lite safety area. (For example the opening cycle towards the wall for systems without safety screens.)

If a person or an object enters the detection range of the according secondary closing edge sensor, the opening cycle is stopped (n=0). When the menu is set to n=1, the door opens at low (creep) speed. The leaves continue opening at normal speed after the obstruction has been removed.

Securing the main closing edge (IN3)  
(See connection diagram of function module)

Presence sensors monitor the passage between the sliding leaves in their closing direction.

If a person or an object is within the detection range of the presence sensor, the closing cycle is reversed into an opening cycle.

#### 4.2 Setting the Panic Closing Function (IN 4) see wiring diagrams of function module

The Panic Closing Function is subject to special legal provisions, therefore the provisions of the relevant country have to be observed.

The Panic Closing Function has to be set via the PDA for safety reasons.

The Panic Closing Function must be triggered via safety deactivation (Totman system).

#### Basic requirements:

The Panic Closing Function must be set.

#### Function:

Press and hold the push button to close the door.

- The door only performs a closing cycle while the push button is pressed.
- The door will close immediately (it will even stop an opening cycle).
- The safety functions: blocking sensor, safety beams and radar motion detectors are deactivated.
- The door closes and locks.
- Should the door be blocked by a person or an obstacle during this closing cycle, the door will close with maximum force.
- In this mode the door will not respond to an activation via NIGHT-/BANK, INTERNAL, or EXTERNAL SENSORS.

- This procedure is only stopped when the motor is overloaded. The motor will switch off for 10 seconds after 10 seconds of constant operation. On expiry of the 10-second break, the closing action is repeated until the door closes and locks successfully (the blocking is removed).
- If the motor overloads, this error may be acknowledged by setting the program switch to CLOSE position. This resets the waiting period in order to enable a prompt response of the door.

#### Resetting the Panic Closing Function

The program switch has to be set to CLOSE position.

- The system has now quit the Panic Closing Function.
- By setting the program switch to CLOSE position, the control unit resumes the normal functions.

#### 4.3 Door status contacts see connection diagram

Door status contact 1 (OUT-1) (default "door open")  
The relay contact is closed when the door performs an opening cycle, is in "open position" or performs a closing cycle.

Door status contact 2 (OUT-2) (default "door closed")  
The relay contact is closed when the door is in the "closed position".

Door status contact 3 (OUT-3) (default "malfunction")  
The relay contact is closed in the event of a malfunction.

Door status contact Bell contact (OUT-4)  
The relay contact is closed when one or both safety beams are interrupted. The function is deactivated when the door is closed.

### DCW address 49

 The system must be disconnected from power supply while the DCW address of the function module is set.

#### Setting the DCW address:

Set DIP switch 1 of the function module to ON position and DIP switch 2 to CLOSE position.

The DCW address 49 is now set.

#### 4.4 Disabling the airlock (IN 3)

As soon as the airlock function is activated while the door is still closed INTERNAL and EXTERNAL ACTIVATION SENSOR signals are blocked.

An opening or closing cycle cannot be interrupted. All airlock functions are realized via direct wiring (no bus connection). The different functions may be realised as follows:

#### Airlock function:

Door 2 is disabled during the opening cycle of door 1. (internal and external activation sensors are deactivated.)

The locking function is disabled as soon as the door is closed.

Door 1 is locked during the opening cycle of door 2. (internal and external activation sensors are deactivated.)

The locking function is disabled as soon as the door is closed.

#### 4.5 Door status contact 2 (OUT 2) (Disabling of airlock if required)

The relay contact is closed as soon as the door starts an opening cycle. (Same function as function module with "DCW address 48".)

#### 4.6 Panic Closing Function (IN 4) & Door status contact 1 (OUT 1) Same function as function module with "DCW address 48".

#### 4.7 Bell contact (OUT 4)

The relay contact is closed when one or both safety beams are interrupted. This function is deactivated when the door is closed.

## 5. Care and maintenance

The unit must be checked and, if necessary, serviced before it is commissioned for the first time and thereafter as required, but at least once a year by a specialist engineer or by authorised specialist personnel.

#### Wear parts:

The following wear parts must be checked in regular intervals and replaced if required in order to ensure the smooth function of the unit.

- Track rollers every 2 years
- Rechargeable battery pack every 3 years
- Rubber end stops at every service check
- Track rail every 5 years
- Toothed belt every 1,000,000 opening/closing cycles
- Floor guides at every service check
- Brushes (optional)

We recommend to conclude a maintenance contract with DORMA.

#### Cleaning:

During cleaning, the program switch must be set to CLOSE or PERMANENT OPEN in order to avoid inadvertent movements of the door.

The entire sliding door unit (aluminium, glass, covers) can be cleaned with a damp cloth and normal commercial detergents. The safety beams have to be cleaned with a dry cloth and the floor guide rails must be cleaned.



**Service display**

The service display informs the facility operator that the door system has to be serviced.

The maintenance intervals can be adjusted via PDA. Either a time slice (monthly interval, e.g. every 6 months) and/or a certain number of opening/closing cycles can be selected (e.g. following 80,000 opening/closing cycles).

Depending on the selected interval, the service display blinks as follows:

Max. number of adjusted opening/closing cycles reached:

- Display illuminates permanently.

Time interval expired:

- Display blinks (every 0.5 seconds).

Time and opening/closing cycle interval reached:

- Display illuminates permanently for 10 seconds, then it blinks for 10 sec.

**Test cycle**

With the aid of the PDA, a test cycle may be performed in order to optimise the smooth performance of the door.

**Briefing**

Following successful commissioning and functional testing of the unit, the documentation has to be handed over to the facility operator and a briefing has to be made.

## 6. Operation instructions

### 6.1 Program switch

The program switch is installed in one of the vertical door jambs. The following functions can be selected using the three toggle switches:

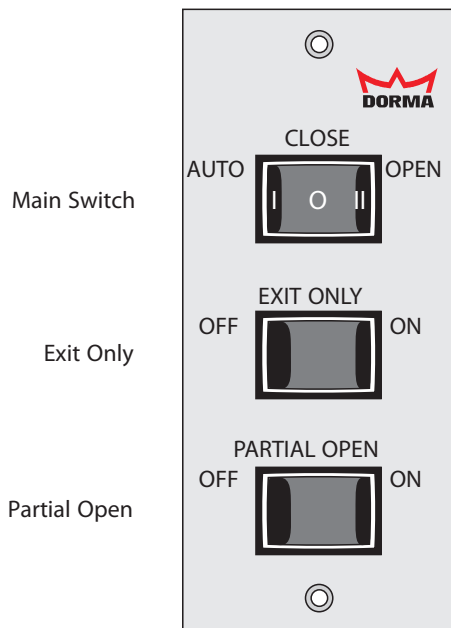

**Main Switch**

Switch is in position:

**AUTO**



When an activation signal is received at either Radar 1, (assuming the EXIT ONLY switch described below is "CLOSE"), and/or Radar 2 inputs, the door will open. After opening, signals received from the Presence input or the Safety Beams, will cause the door to remain open, open again when the door is closes.

After all the sensors have cleared, the hold open delay is initiated, and when it expires, the door will close.

**OPEN**



**Continuous Open Operation**  
The door opens to the full opening width and remains in this position. Manual operation of the door is possible, with some resistance from the operator.

**CLOSE**



The door stops immediately when the switch is placed in this position. Manual operation of the door is possible, with some resistance from the operator.

**Switch - EXIT ONLY**

(Main Switch is in AUTO position)

Switch is in position:

**ON**



In this position the exterior motion sensor is switched off for activation, the door can only be activated from the interior motion detector (e.g. one-way traffic function after a store has closed). The exterior Radar 1 is active while the door is open and cuts off in the closed position.

When an activation signal is detected from the interior (Radar 2), the door opens, delays according to the hold open time setting, then closes.

If, in addition, the Partial Open Switch is set to the ON position, the door opens only to the predetermined partial open position and closes after the expiration of the hold open delay.

**CLOSE**



The Exit Only function is switched to "CLOSE".

**Switch - PARTIAL OPEN**

(Main Switch is in the AUTO position)

PARTIAL OPEN Switch is in position:

**ON**



If the Partial Open Switch is set to the ON position, the door opens only to the predetermined partial open position and closes after the expiration of the hold open delay. If, in addition, the EXIT ONLY switch is in the ON position, then the door can be activated only from the interior devices; the exterior motion detector is switched to close.



## 6.2 Setting the PARTIAL OPEN width

The PARTIAL OPEN width can be adjusted with the PDA. The PDA can also be used to disable the setting via program switch, so that settings can only be made with the PDA.

The opening width of the door can be adjusted individually. Starting from the full opening width, a reduced opening width = partial opening width may be set (e.g. in winter to reduce drafts.)

1. Close the door.
2. Set program switch to PERMANENT OPEN
  - The door opens at low (creep) speed.
3. As soon as the door reaches the desired partial opening width, set the program switch to PARTIAL OPEN and the main switch to close.
  - The door stops
  - The control unit stores the desired position.
  - The door performs a closing cycle.

## 6.3 Emergency Breakout

The program switch is set to AUTOMATIC, PARTIAL OPEN or EXIT ONLY.

Breakout any panel:

- The door stops immediately
- The leaves may be moved manually.

## 6.4 Start-up following a power failure

After a power failure, the control unit performs a self-check of approx. 5 sec. for safety reasons.

The door then closes at low (creep) speed and resumes the preset program function.

## 7. Troubleshooting

How does the control unit respond to a short circuit?

The 27 V power supply for radar motion detectors, the locking device etc. is short circuit proof. In the event of a short circuit, both control LED lights of the safety beams go out and the 7-segment display indicates error 3 (program switch) Once the short circuit is removed, the 27 V power supply is restored automatically.

- Have all maintenance intervals been observed/has the maintenance been performed?
- Have all wear parts been checked and replaced if required?
- Is the power supply connected?
- Is the Breakout Switch making contact?
- Is the program switch set correctly?
- Are the areas monitored by the safety beams clear and clean?
- Is the door blocked by an obstruction?
- Is the door running smoothly (counter rollers, floor guides)?
- Are all external activators, EMERGENCY OFF push button, program switch and locking device connected correctly?
- All connection points checked?
- Is the rechargeable battery pack correctly connected?

For further assistance, consult the following troubleshooting table.

Should you perform installation work, disconnect the power plug and the battery pack in order to keep the control unit voltage-free. After a fault is redeemed, the error code must be deleted.

Reset error codes:

Set program switch to CLOSE.

Fault	Possible causes	Remedy
Door runs jerkily and out of control	The incremental encoder cable is defective	Replace cable
	The connector cable is not fixed properly	Fit connector cable properly
Door remains open after cyclic self-check (every 4 hours).	The rechargeable battery pack is not fully recharged or empty	Check battery voltage Change rechargeable battery pack
Door remains open, in all program switch settings	Safety beams effected	Check safety beams function with the help of the LED on the basic module.
	EMERGENCY OFF push button	Short the connector inputs. If fault is cured by this, check EMERGENCY OFF push button, and exchange if necessary, then check with the help of the PDA.
Door remains open in the program switch settings: AUTOMATIC, PERMANT OPENING, and PARTIAL OPENING	Detector is emitting a continuous signal	Remove connector of sensor motion. If fault is cured by this, replace it
Basic module indicates error "1" (obstruction during commissioning)	The learning cycle has not been performed (the door weight is still undetermined)	Perform learning cycle
	The obstruction detection is too sensitive for the door set (e.g. small, high and heavy door leaves)	Adjusting the obstruction detection via force limitation (OPEN, CLOSE) and the delay time via the PDA
Door does not open when the program switch is set to: AUTOMATIC, EXIT ONLY, PERMANT OPEN, and PARTIAL OPEN	External and internal motion sensor	Remove activator connector and short the input. If the fault is cured by this, check supply voltage (27 V) of the basic module and the sensors. If it is okay check and replace sensors if required.
Unpleasant operating noise	Screw presses against track roller	Replace or trim screw

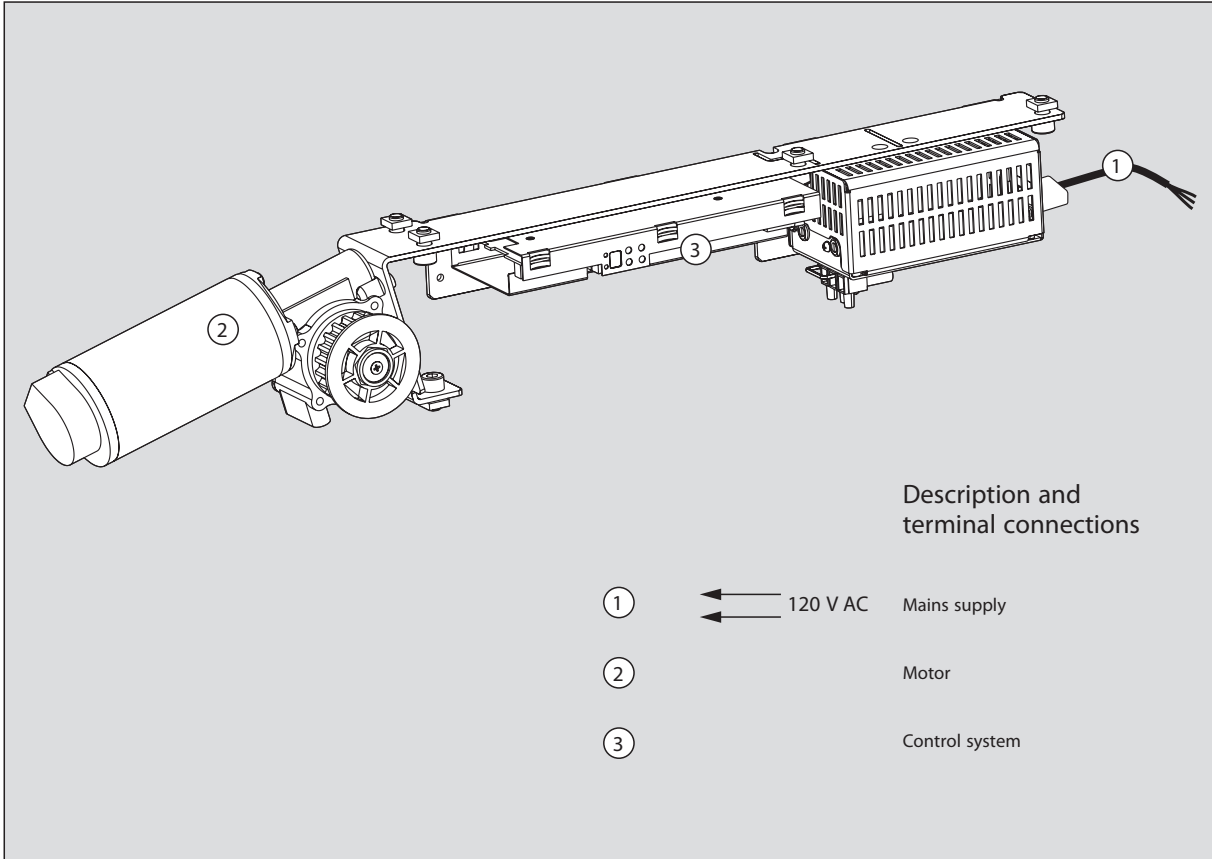

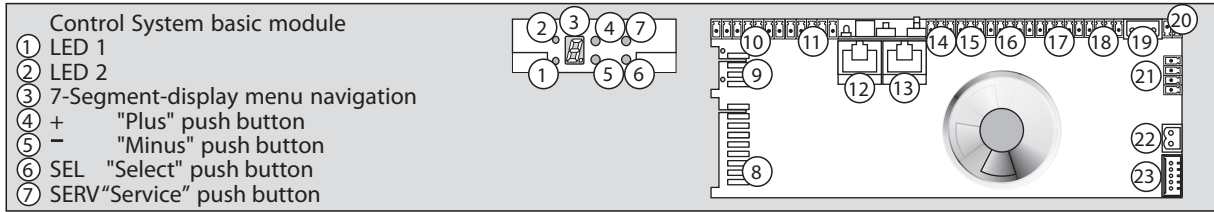

Description and terminal diagram

When connecting a DCW device via cable, the wiring has to be checked again. Interchanged DCW connections (e.g. 27 V DC to A or B), or missing GND connection, may destroy all connected DCW devices.

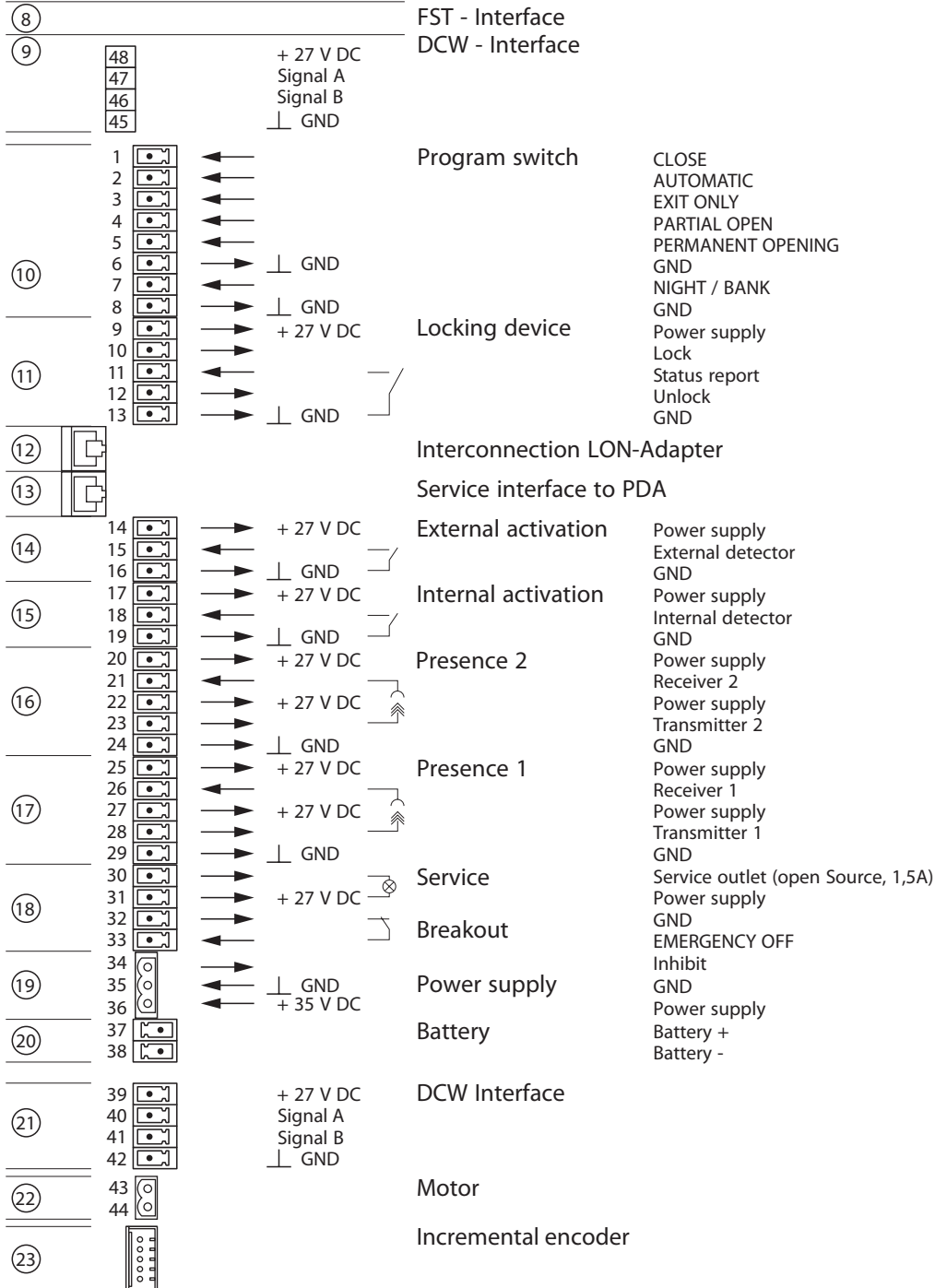

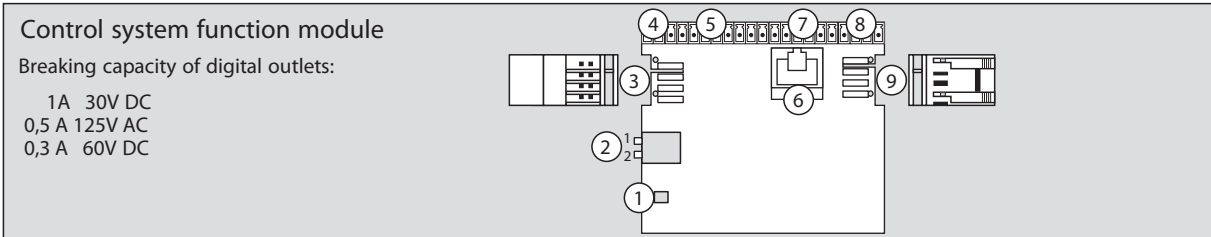

Description and terminal diagram



When connecting a DCW device via cable, the wiring has to be checked again. Interchanged DCW connections (e.g. 27 V DC to A or B), or missing GND connection, may destroy all connected DCW devices.

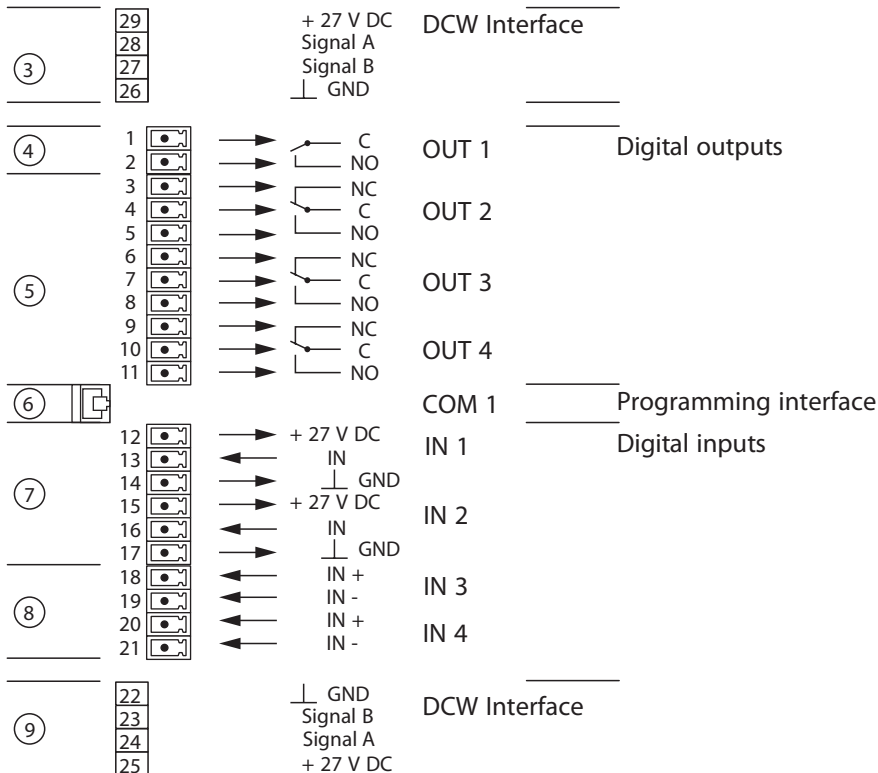

DCW Adresse	Original settings	Digital inputs				Digital outputs			
		1	2	3	4	1	2	3	4
DCW Adresse 48 	Secondary closing edges Sensor 1	X							
	Secondary closing edges Sensor 2		X						
	Main closing edge			X					
	Panic closing function				X				
	Door status contact 1 "DOOR OPEN"					X			
	Door status contact 2 "DOOR CLOSED"						X		
	Door status contact 3 "OPERATIONAL FAULT"							X	
	Door status contact 4 Bell contact								X
DCW Adresse 49 	Disable airlock Entrance (disables the door)			X					
	Panic closing function				X				
	Door status contact 5 Door closed					X			
	Door status contact 6 Disable airlock (exit)						X		
	Door status contact 7 Airlock impulse (exit)							X	
	Door status contact 8 Bell contact								X

② DIP switch  
① LED status indicator

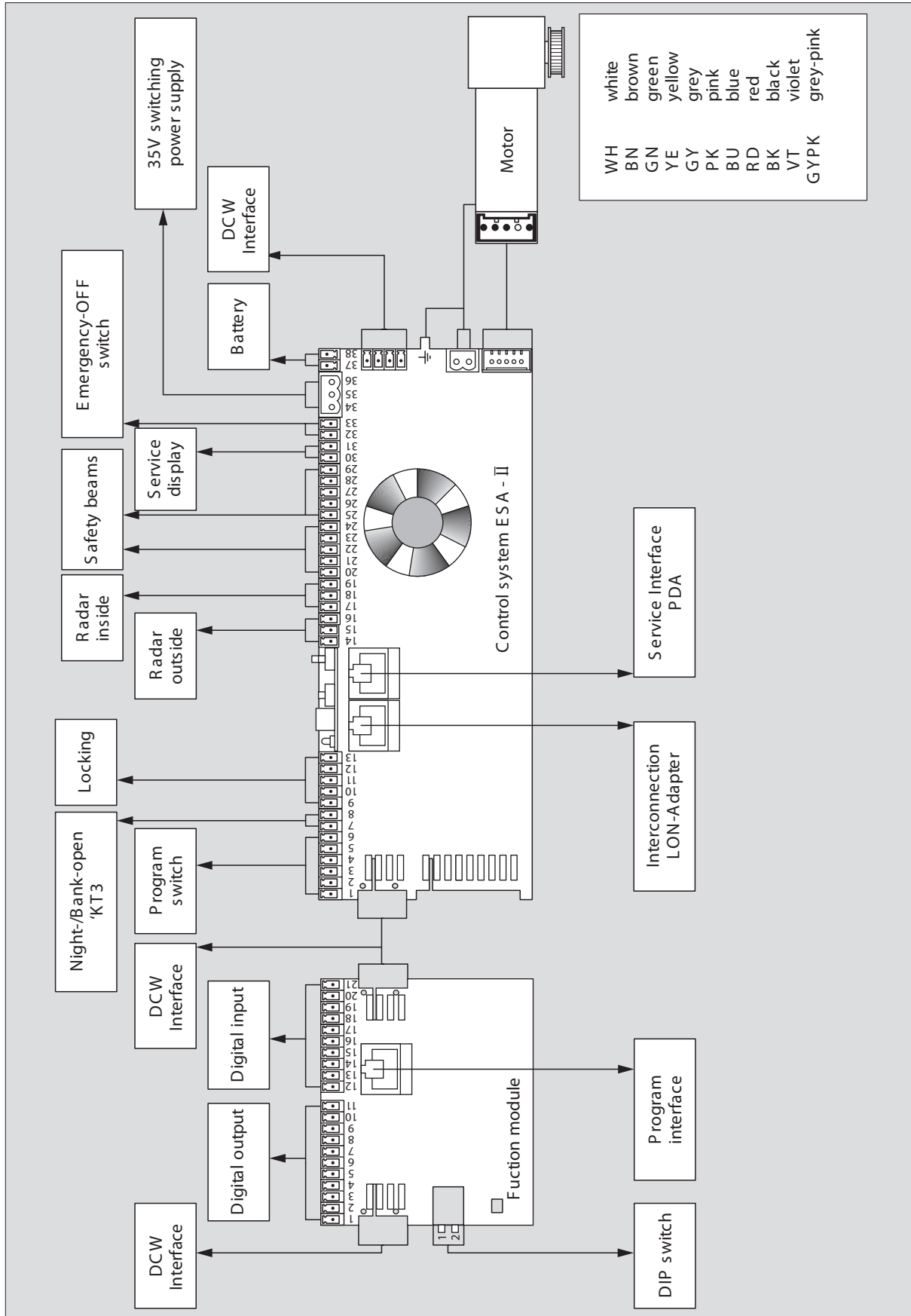

Wiring diagram of the motor, control system and power supply

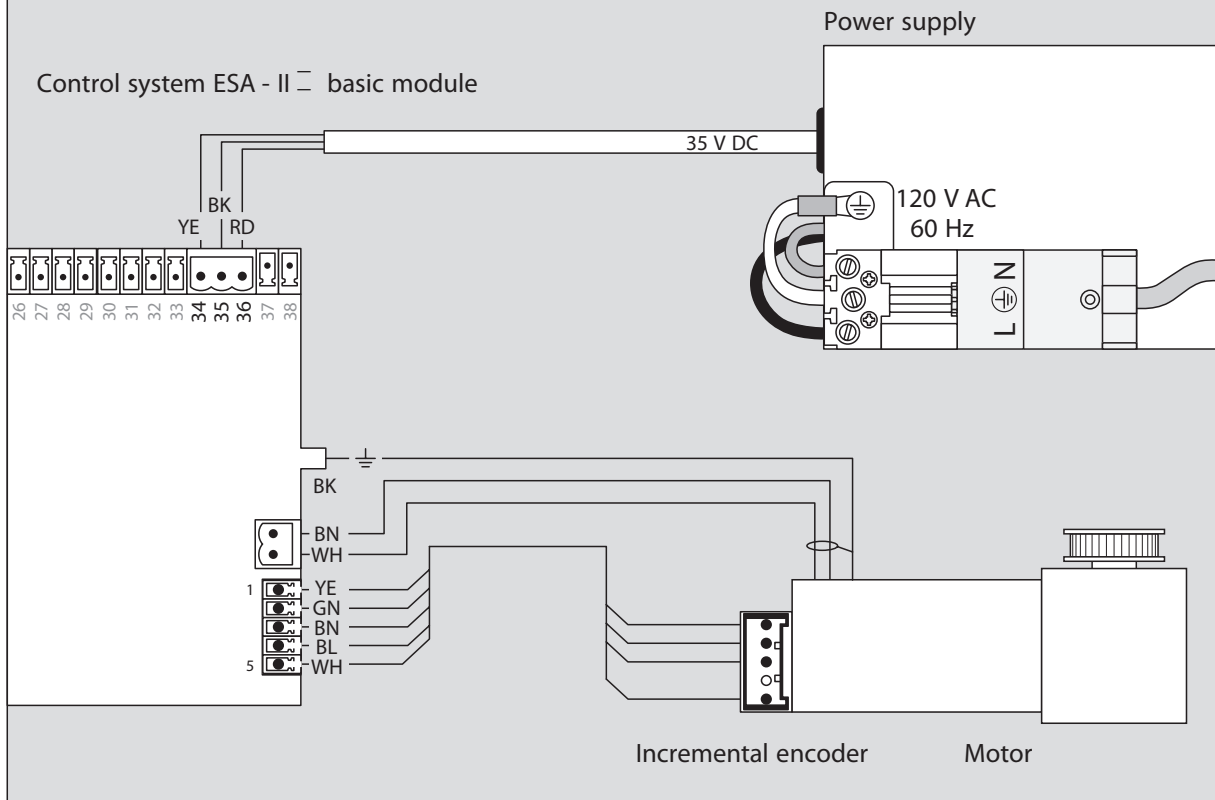

Wiring diagram Night-/Bank-open

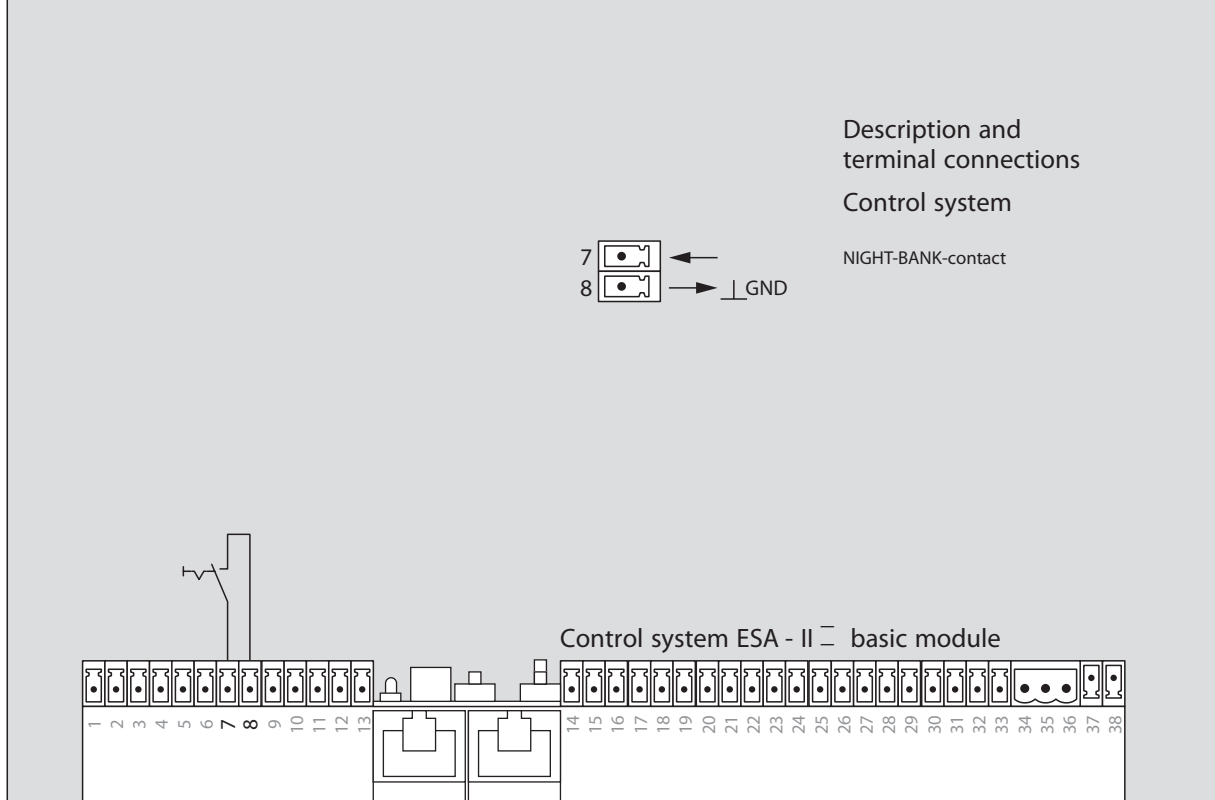



Wiring diagram breakout-cutoffswitch (optional)

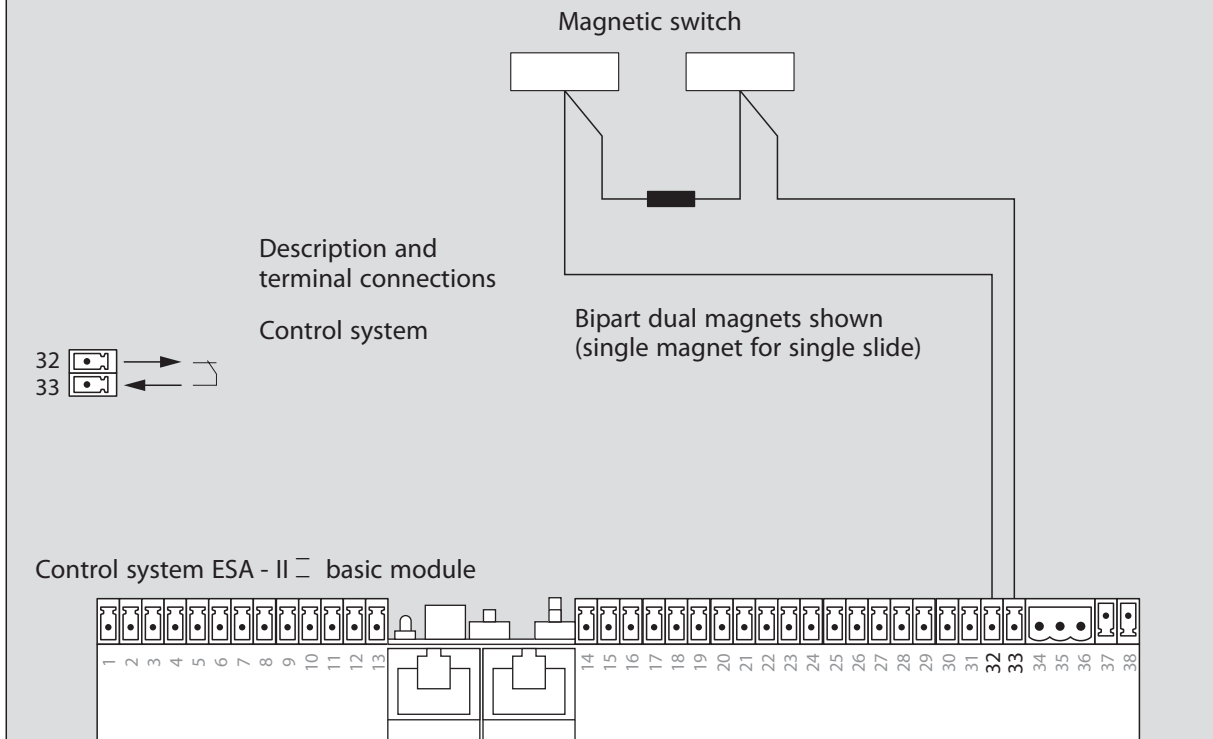

Wiring diagram without breakout-cutoff switch

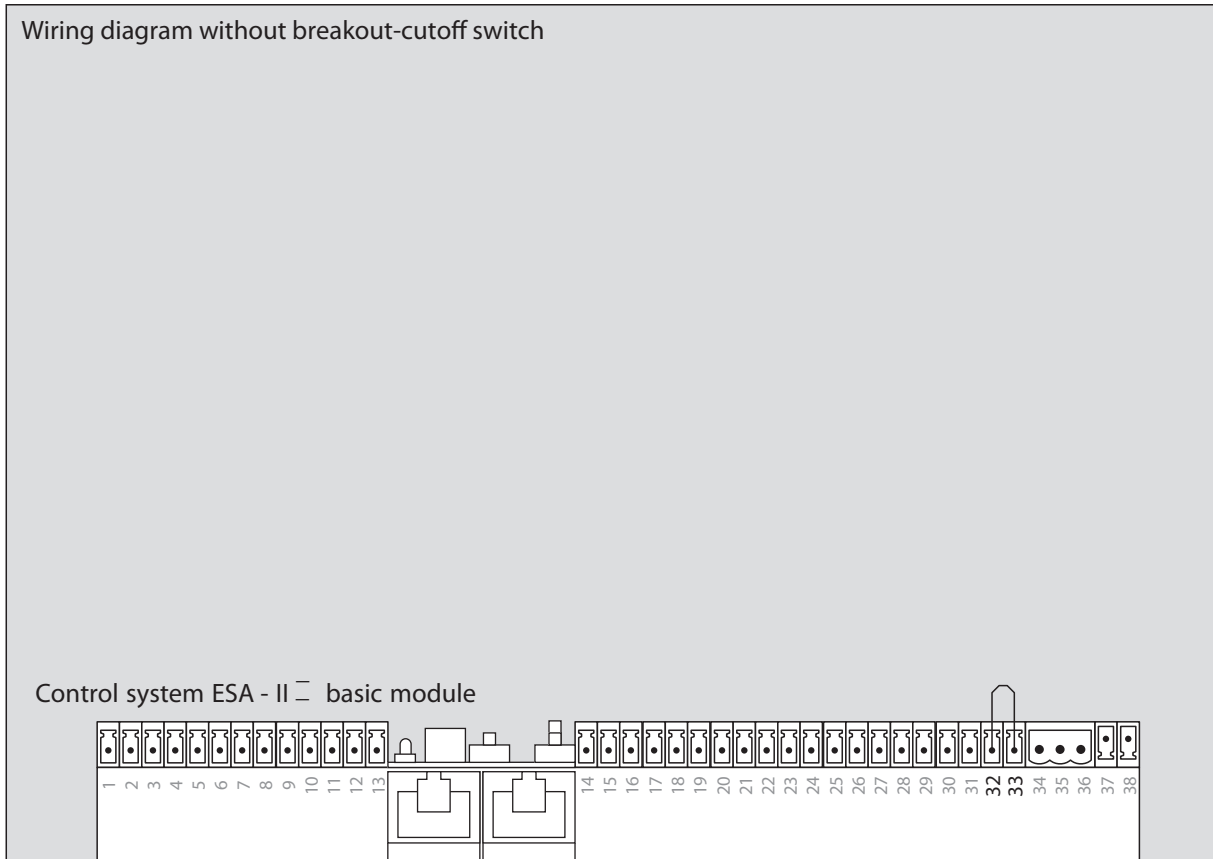

Wiring diagram of the battery (optional)

- Battery:
- Attach **ONLY** for the functional test and immediately before the commissioning.
  - Disconnect the battery before servicing the ESA - II

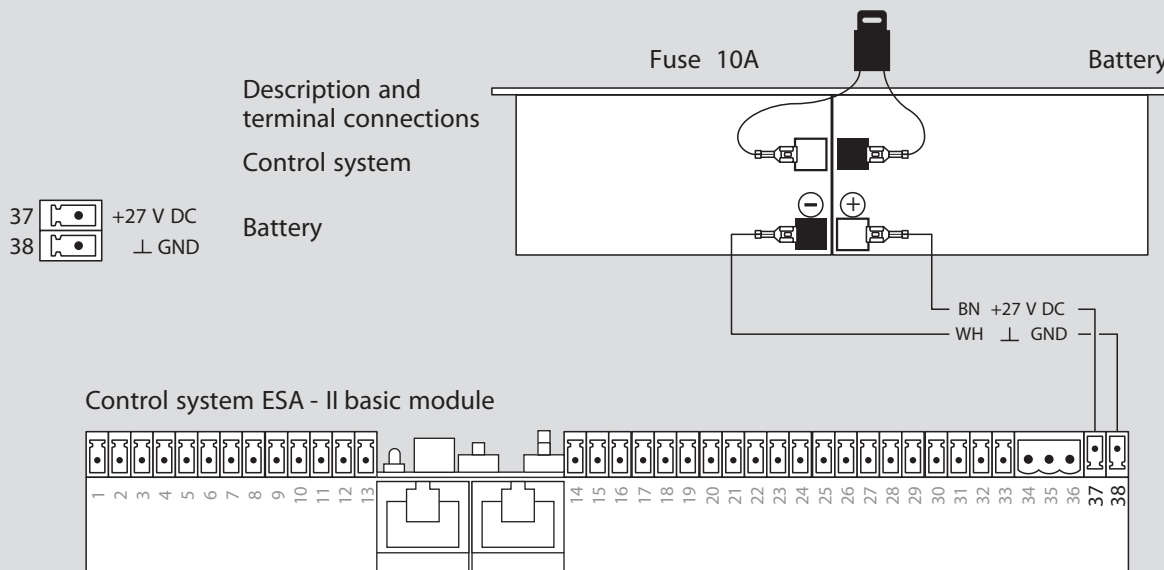

Wiring diagram Program switch

**Description and terminal connections**

**Control system**

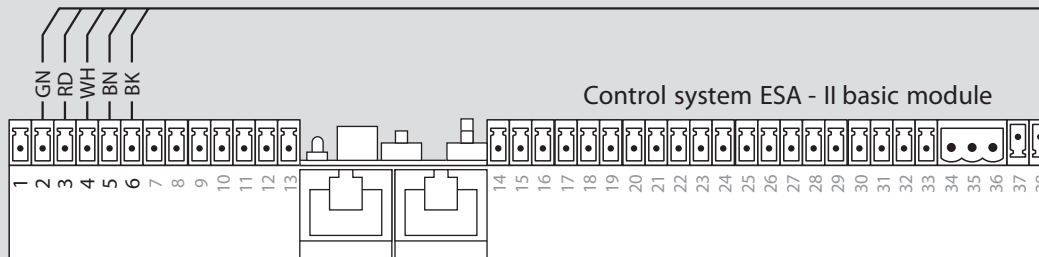
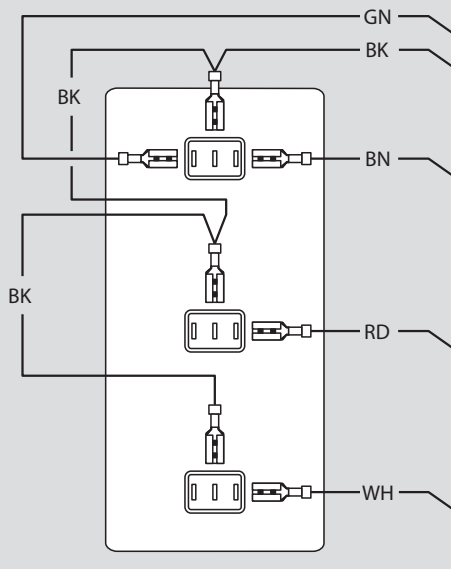
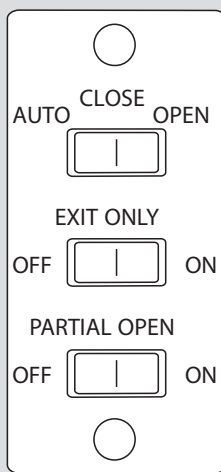
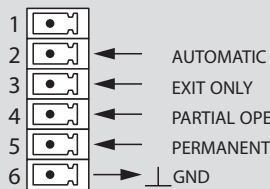

Wiring diagram motion detector / presence sensor (BEA) and (Bircher Reglomat)

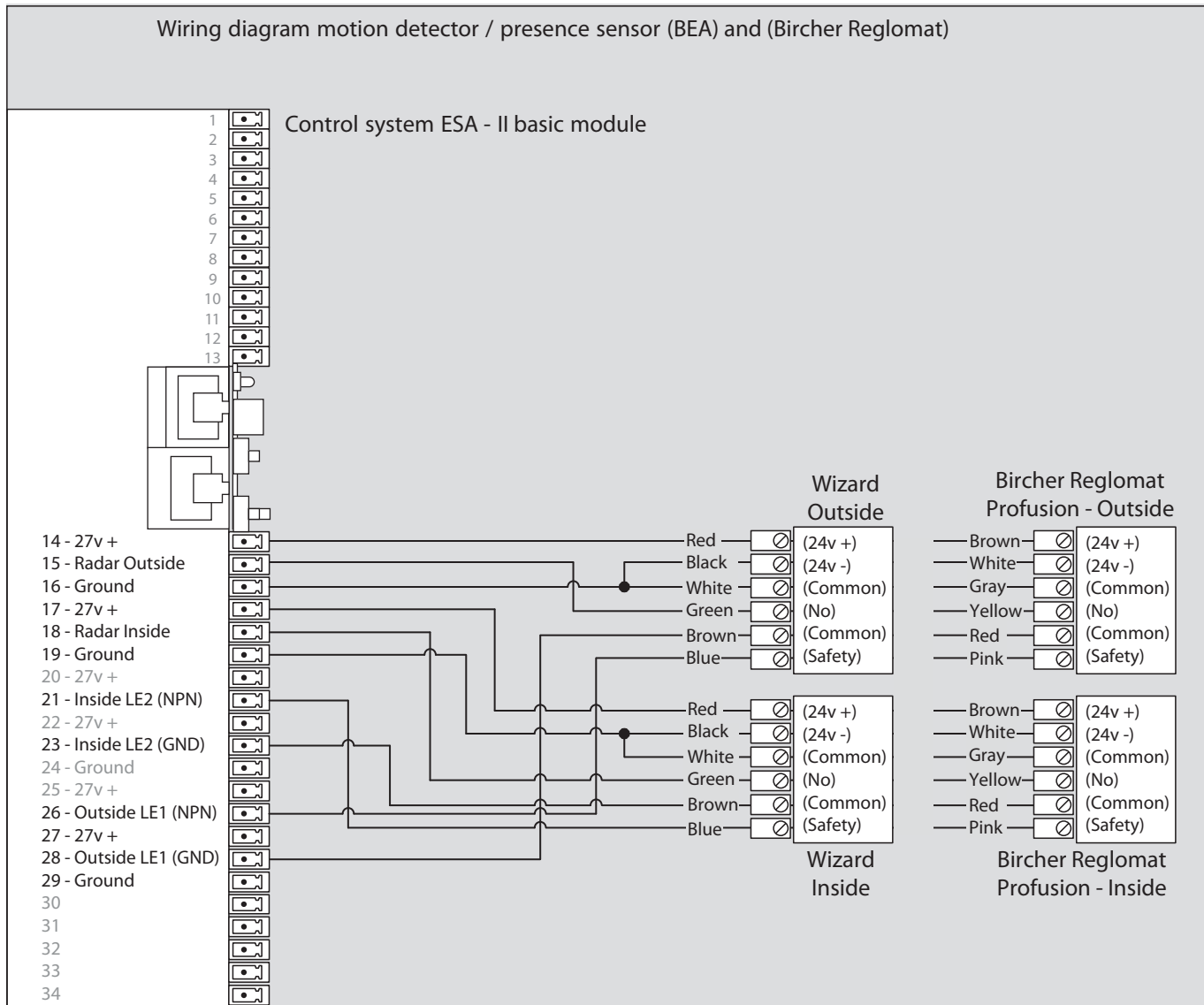

Terminal 21 to 23 and terminal 26 to 28 must have a N.C. circuit.

Wiring diagram motion detector / presence sensor (BEA)

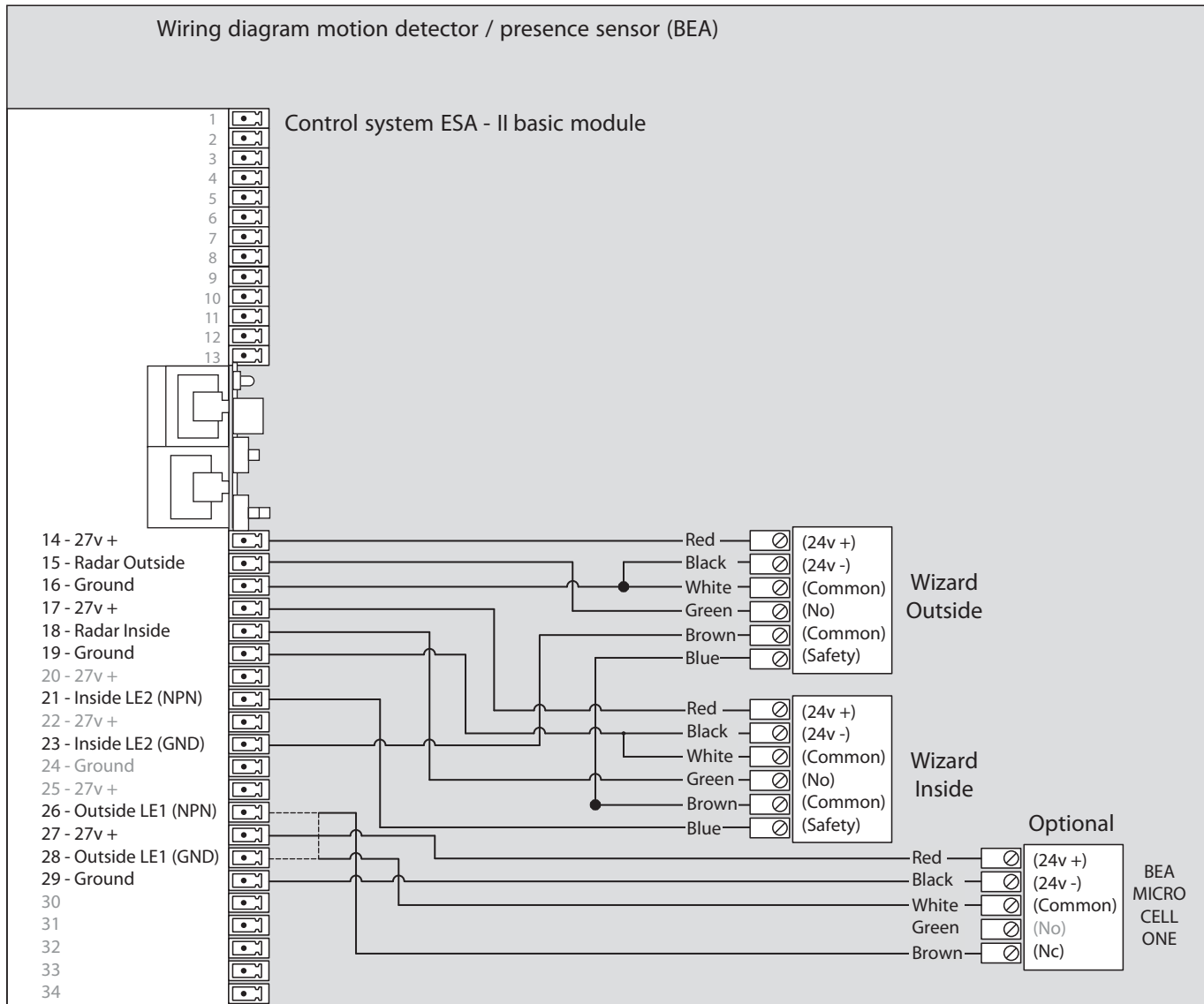

When beams are not used, jumper terminal 26 and 28.

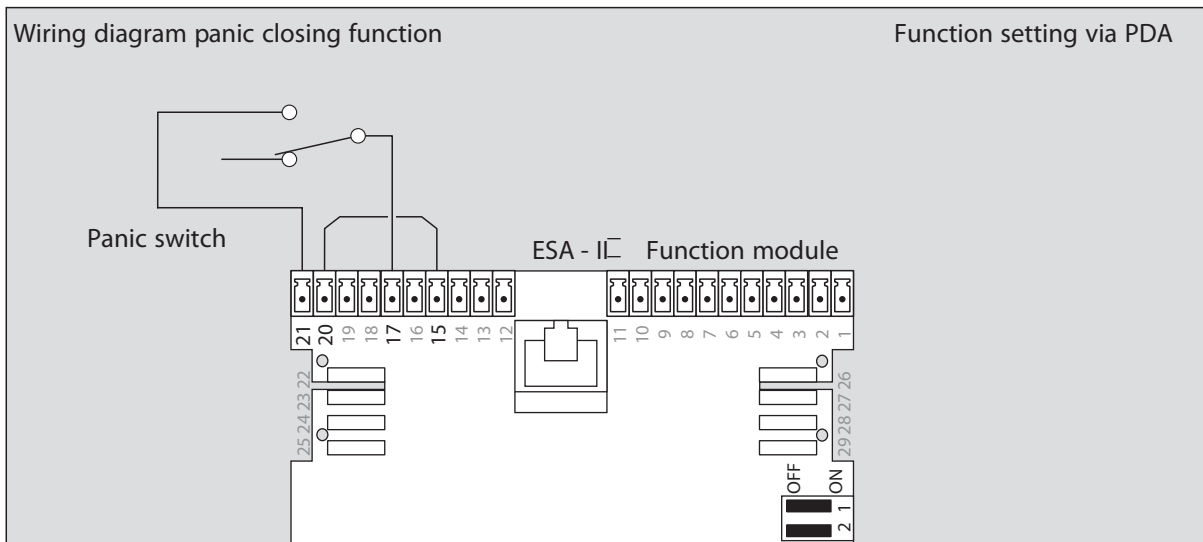

Does not meet BHMA / ANSI 156.10  
 This function overrides all safety devices  
 Door will close if switch is activated

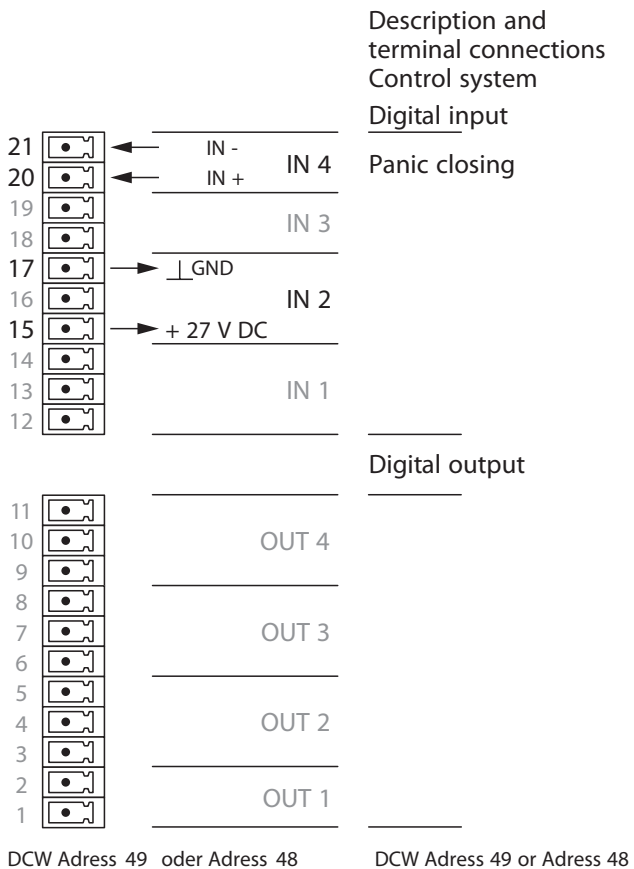

DCW Adress 49 oder Adress 48

DCW Adress 49 or Adress 48



Wiring diagram for electric lock

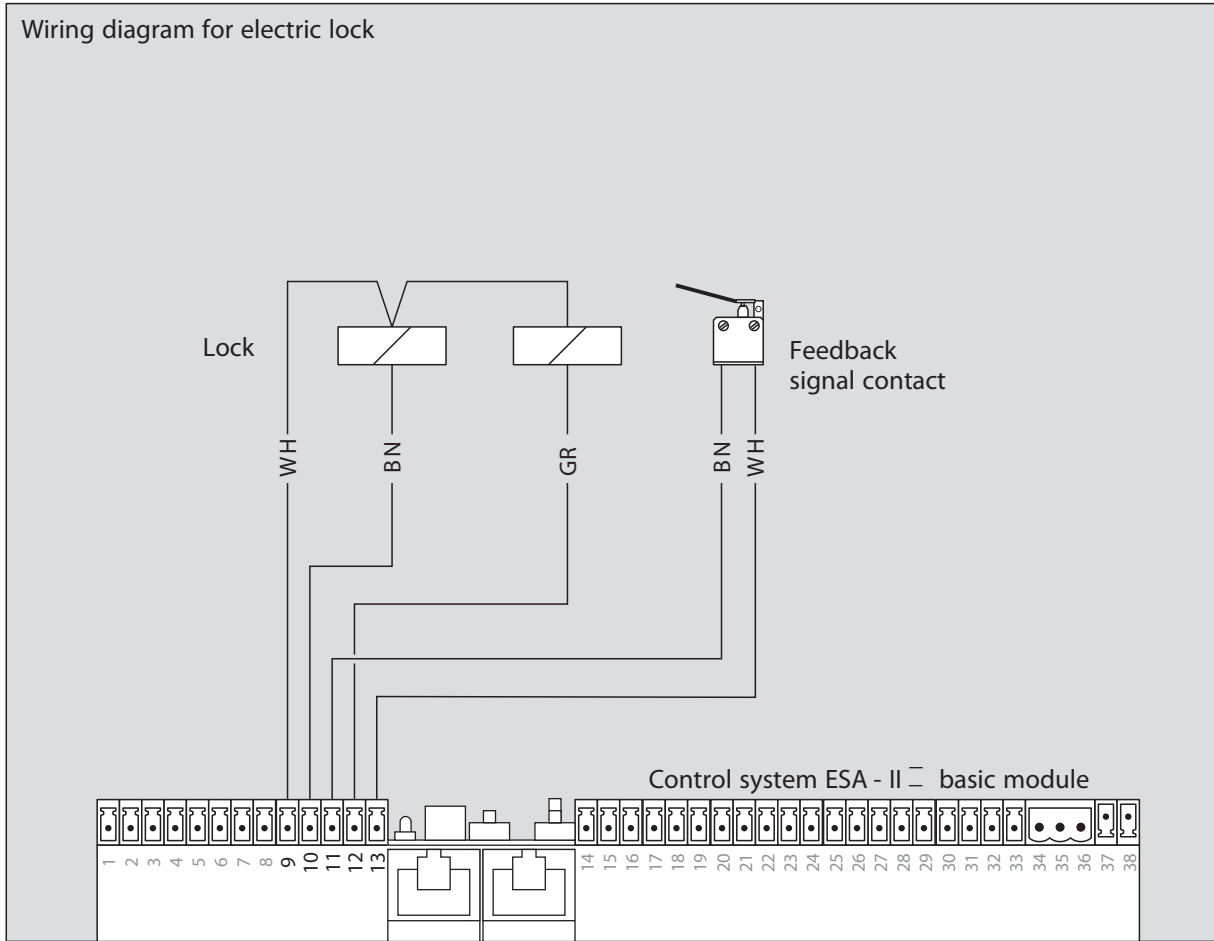

Description and terminal connections

Control system

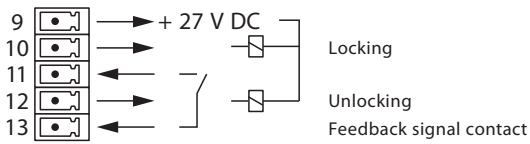

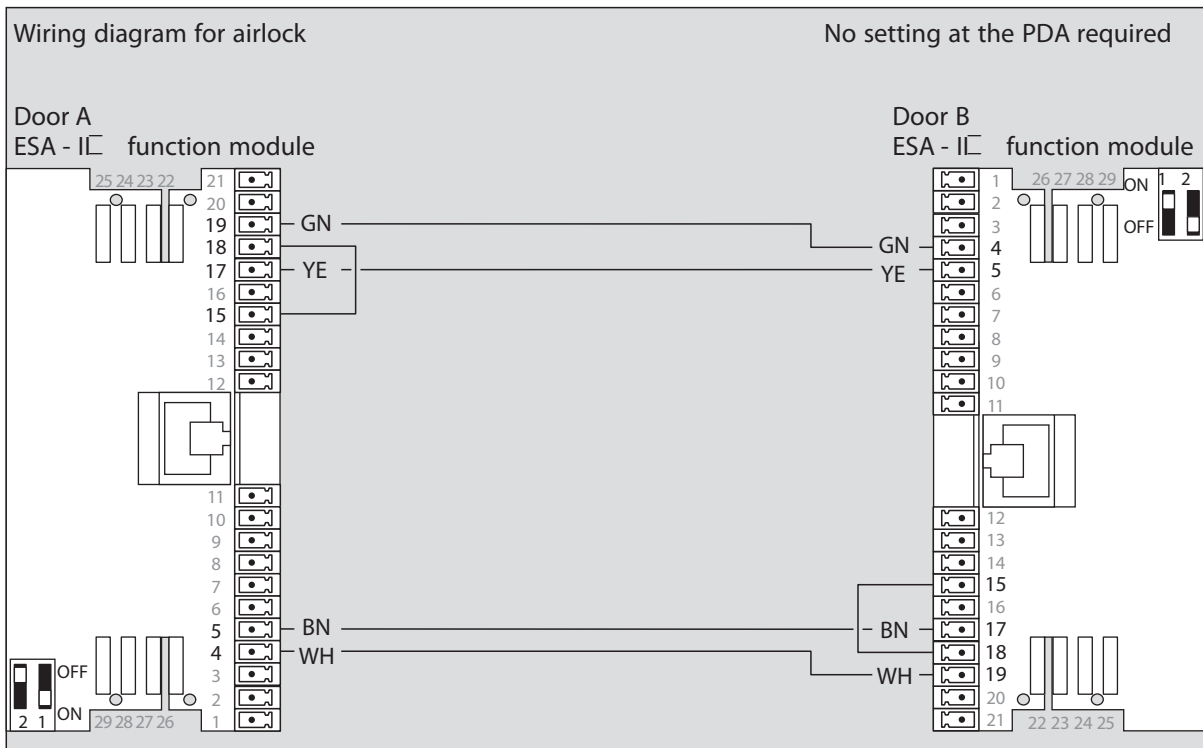

Description and terminal connections  
Door A and B: Control system  
Digital input

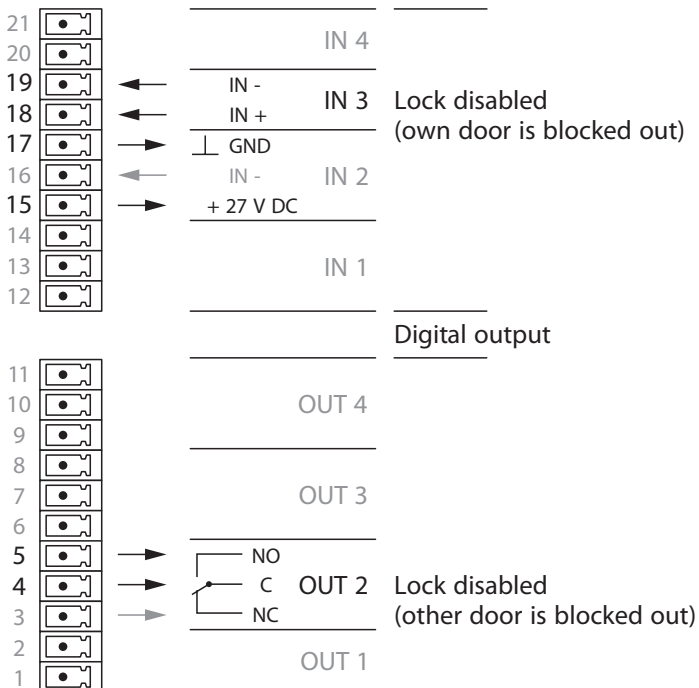

DCW Adresse 49





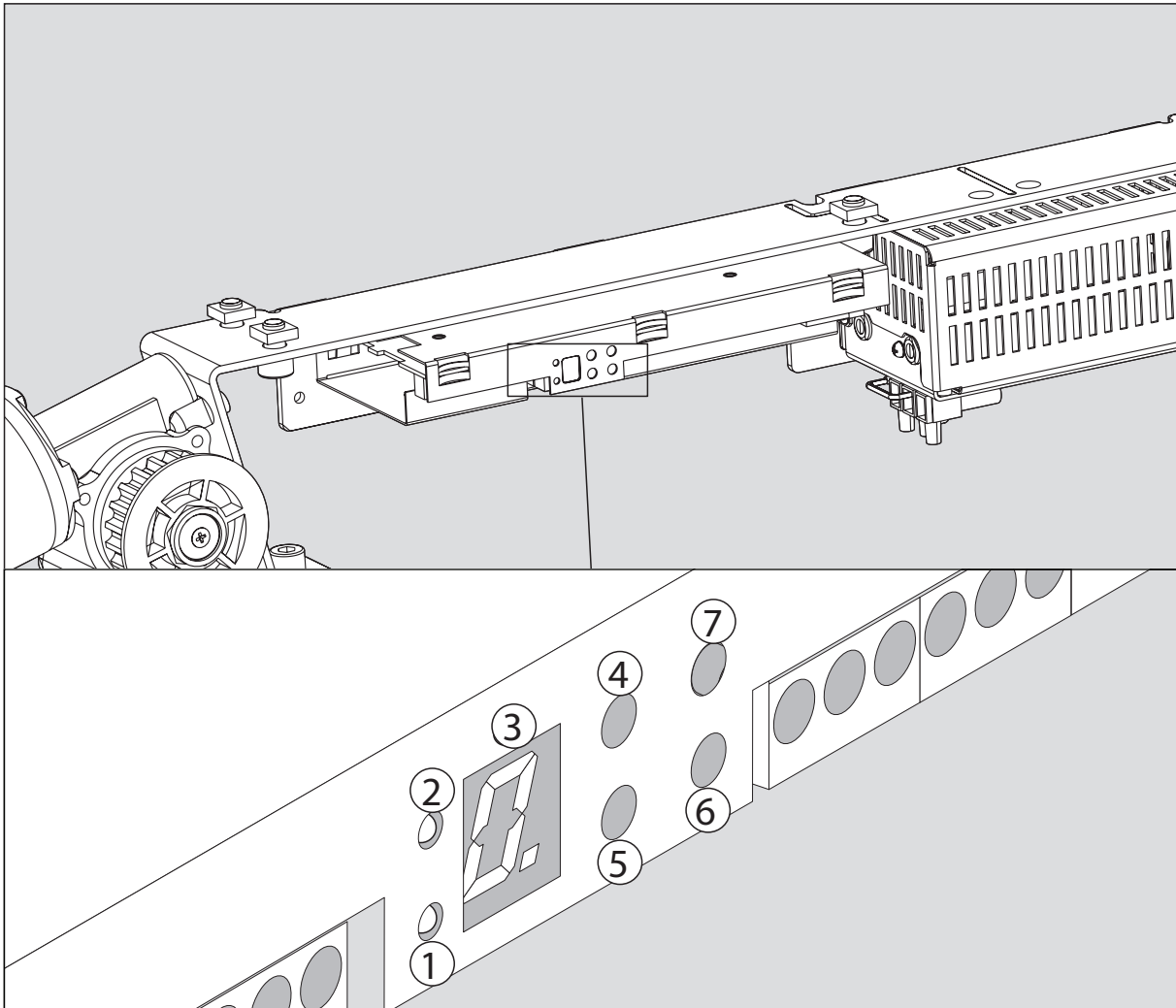

- |   |                    |   |
|---|--------------------|---|
| ① | LED 1              | Status information of safety sensor 1 (e.g. safety beam)            |
| ② | LED 2              | Status information of safety sensor 2 (e.g.) safety beam            |
| ③ | 7-segment-display  | Display unit for indicating numbers and symbols                     |
| ④ | + UP push button   | for increasing the parameter or value indicated                     |
| ⑤ | - DOWN push button | for decreasing the parameter or value indicated                     |
| ⑥ | SEL.     SELECT    | Push button for MENU control  |
| ⑦ | SERV.     Service  | Push button for performing the functions of the service push button |

## Description of menu structure

Display when in operation  
Basic display setting when the operator is functioning correctly



Basic display setting when the operator is malfunctioning

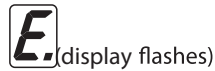

Parameter Display  
Menu for selecting the parameter to be checked or changed

Value Display  
Readout of the value previously selected via the parameter display.

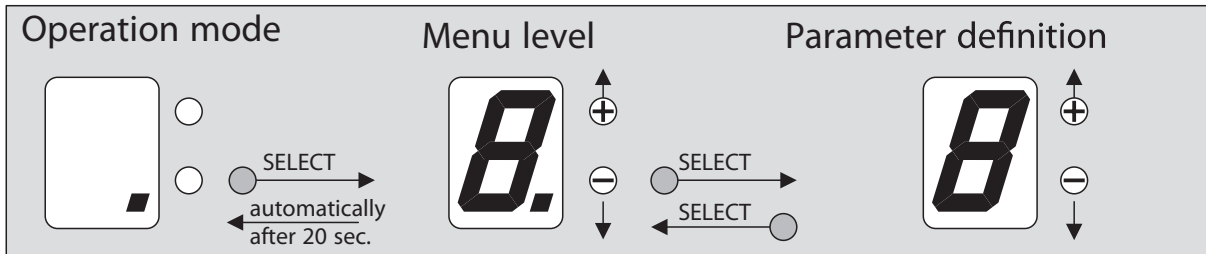

Meaning of display codes	Display codes
Error display	0 - F
Temper block	0 - 1
Locking in Program switch settings	0 - 1
Locking mode	0 - 3
Back up battery operation	0 - 3
Night-bank-hold open time	0 - 9, F
Hold open time	0 - 9, F
Side lite function	0 - 1
Opening speed	0 - d
Closing speed	0 - 4

## Modifying the parameters of the system using the push buttons "+", "-", and "select"

At first the following sequence must be observed when setting the parameters.

1. check and switch if necessary
2. check and switch if necessary
3. check and switch if necessary

## Meaning of display codes

**S.** Temper block  
 Temper block activated  
 Temper block de-activated

**r.** Locking in program switch setting:  
 setting "OFF"  
 setting "OFF" and "EXIT ONLY"

**L.** Interlock type:  
 No interlock  
 Bistable interlock  
 Bistable interlock with status signalling contact (NO)  
 Monostable interlock (fail safe)

**A.** Battery mode  
 no Battery  
 Emergency closing  
 Emergency opening  
 Battery Emergency mode

**0.** Night-/ Bank Hold open time  
 1.5 sec  
 2.5 sec  
 5 sec  
 8 sec  
 10 sec  
 15 sec  
 20 sec  
 25 sec  
 30 sec  
 Adjustment via PDA > 30 sec

**d.** Hold open time  
 1.5 sec  
 2.5 sec  
 5 sec  
 8 sec  
 10 sec  
 15 sec  
 20 sec  
 25 sec  
 30 sec  
 Adjustment via PDA > 30 sec

**n.** Side lite function  
 Stop  
 Closing cycle

**0.** Opening speed:  
 0.4 in./sec  
 0.6 in./sec  
 0.8 in./sec  
 1.0 in./sec  
 1.2 in./sec  
 1.4 in./sec  
 1.6 in./sec  
 1.8 in./sec  
 2.0 in./sec  
 2.2 in./sec  
 2.4 in./sec  
 2.6 in./sec  
 2.8 in./sec  
 3.0 in./sec

**L.** Closing speed  
 0.4 in./sec  
 0.6 in./sec  
 0.8 in./sec  
 1.0 in./sec  
 1.2 in./sec

The hold-open time, adjusted via the PDA, is also indicated on the 7-segment display of the control unit. As the display of the control unit follows a certain pattern (see above), it always indicates the next value below. For example:

Adjustment of PDA = 14 sec => display of control unit = 5

Adjustment of PDA = 21 sec => display of control unit = 7

This is also the case with the Night-/ Bank hold-open time.

 According to BHMA / ANSI 156.10, the Hold-open time and the Night-/Bank Hold-open time have to be adjusted to at least 2.5 sec. when light barriers are applied.

Query of error messages

Only the current error can be acknowledged  
(The errors must be corrected before resetting)  
Up to 10 errors can be stored (regardless of type)

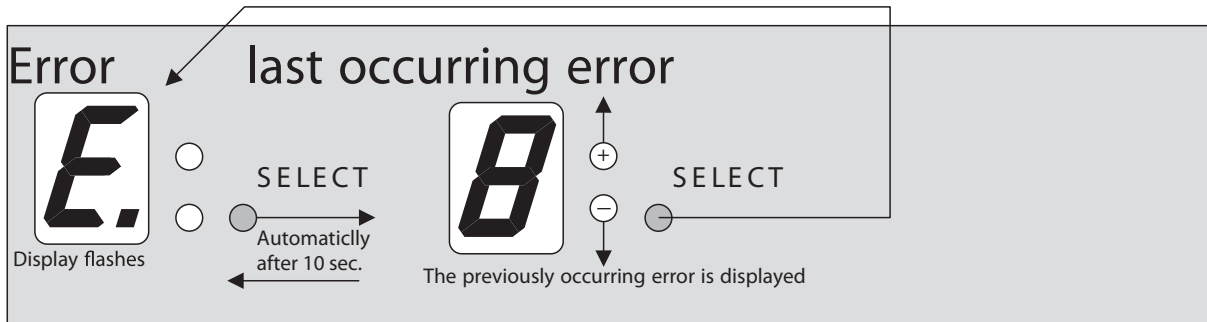

Meaning of display codes

<b>0</b>	No error in memory
<b>1</b>	Obstruction
<b>2</b>	Lock
<b>3</b>	Program switch
<b>4</b>	Safety beam
<b>5</b>	Incremental encoder
<b>6</b>	Back up battery test error
<b>7</b>	System
<b>8</b>	Breakout operated
<b>9</b>	Learning cycle parameter error
<b>A</b>	Motor fault
<b>b</b>	Battery test error
<b>c</b>	Force test
<b>d</b>	Overcurrent at motor
<b>F</b>	DCW

Additional error displays appear in the PDA

Error messages appearing on the PDA are explained in the instruction PDA software for ESA - II (ASP)

Meaning of display codes

These errors can only be recorded by the PDA

<b>2</b> Lock	15, 16, 23
<b>3</b> Program switch	22
<b>6</b> Back up battery test error	28
<b>7</b> CPU, RAM, ROM, EE-PROM, Relay test	21
<b>A</b> Motor fault	10
<b>b</b> Battery test error	11
<b>c</b> Force test	12
<b>d</b> Motor overcurrent	13
<b>F</b> DCW	15, 29

Message	Error	Method of acknowledgement
<b>0</b>	No error in memory	
<b>1</b>	Obstruction	Self-knowledge
<b>2</b>	Lock	Turn program switch to CLOSE
<b>3</b>	Program switch	Turn program switch to CLOSE
<b>4</b>	Safety beam	Turn program switch to CLOSE
<b>5</b>	Incremental encoder	Turn program switch to CLOSE
<b>6</b>	Back up battery test error	Turn program switch to CLOSE
<b>7</b>	System, relaistest	Cycle mains
<b>8</b>	EMERGENCY OFF	Release EMERGENCY OFF
<b>9</b>	Learning cycle parameter error	Turn program switch to CLOSE
<b>A</b>	Motor fault	Self-knowledge
<b>b</b>	No battery detected on battery test: Reset performed by contro	Turn program switch to CLOSE
<b>c</b>	Force test "No battery" mode: EMERGENCY OPEN mode: wait until force test in open position porduces "OK"	Turn program switch to CLOSE
<b>d</b>	Overcurrent at motor longer than 30 sec	Turn program switch to CLOSE
<b>d</b>	Commissioning error	Change direction of motor rotation During commissioning, door panels open

During the cycle press



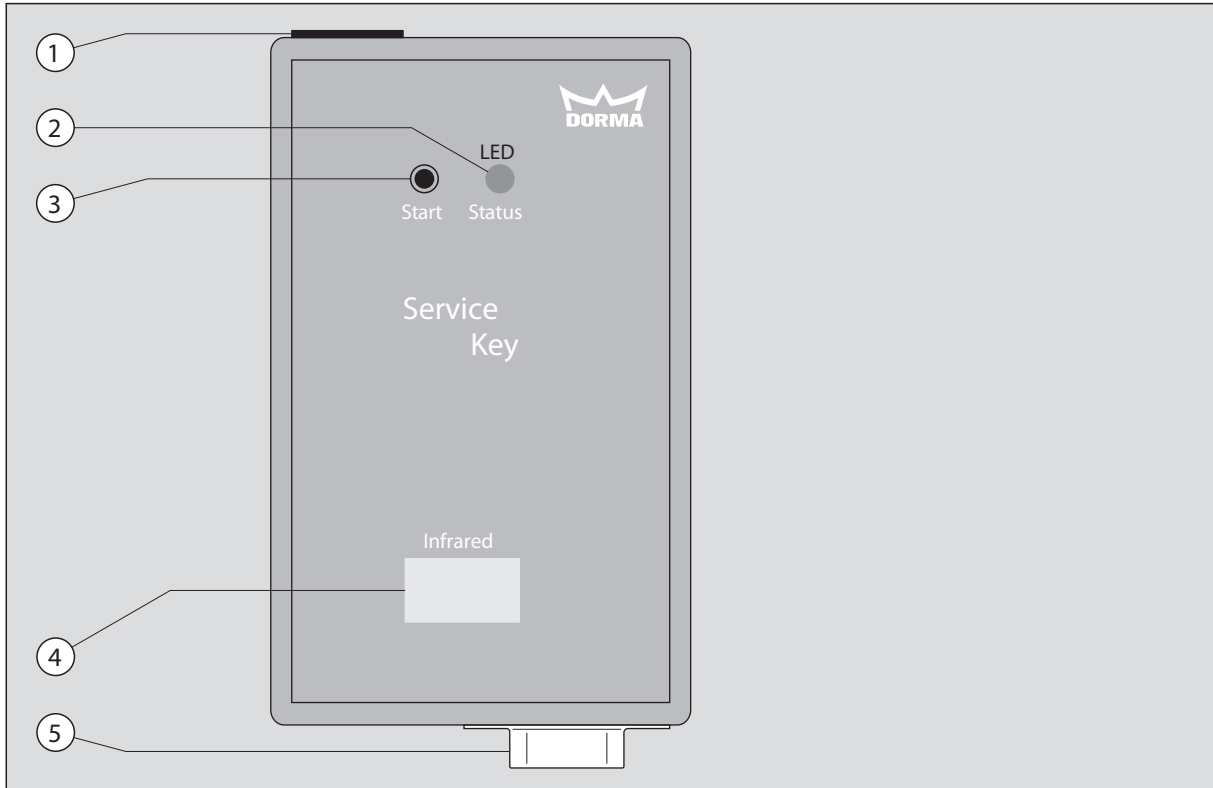

**Description and  
terminal connections**

- ① RJ45            Connecting port for control unit
- ② LED            LED status indicator
- ③                Start push button
- ④                Infrared device
- ⑤ SUB D        Connecting port for PDA

### ESA - II Service-Key

The service key is the linking element between the PDA (Personal Digital Assistant) and the ESA - II control unit. It may also be used with the control unit without PDA in order to disable the control keys of the control unit or to update the software of the control unit.

#### Operation via PDA

The PDA is connected to the service key (9-pole SUB D plug) with a serial connecting cable. Connect the service key via the connecting cable to the control unit (Port 13 behind the service keys). Establish a connection between the controller and the PDA (see ASP operating instructions). The LED status indicator on the service key turns green. Now the settings may be changed via the PDA. An upload must be performed in case that any settings have been changed. The LED status indicator of the service key lights red, in the event, that an error occurs during upload. In this case the upload must be repeated. If the upload was successful, the LED is green. The PDA may also be used to install a new software version on the service key. Software upload from PDA to service key: See "ESA" ASP data base recording.

#### Software update of ESA-II control unit via service key

The service key must contain the latest software version.



The software update may not be done while the door is under operation, as it could get out of control.

Take the ESA - II sliding door out of operation (set Program switch to CLOSE, or use the EMERGENCY OFF push button if necessary.) Press and hold the start push button for three seconds. The LED status indicator on the service key flashes orange while it performs the update. It flashes red in the event that an error occurs during upload. In this case, the upload must be repeated. If the upload was successful, the LED turns green.



Following a software update, the power supply must be reset (battery pack and power plug must be removed for a short time) and a learning cycle has to be performed. The door settings must be checked and reset if required (e.g. locking type, motor type, operation via battery pack etc.).

#### Locking the control panel via service key.

If the control panel of the ESA - II control system is locked, the service key unlocks it, by connecting it.

The settings can now be changed. As soon as the service key is disconnected from the control unit, the control panel is locked automatically.







#### LED status indicator

LED status indicator	Update PDA service key	Update SK control unit
Green	Update successful	Update successful
Orange	Update in progress	
Red	Error during update	
Orange (flashing)		Update in progress
Red (flashing)		Error during update

#### Troubleshooting

The control unit indicates an error code in the event of an incomplete update.

The LED status indicator on the service key goes out.

Error code	Possible reasons	Error display
01	System	
03	Program sequence	
05	RAM error	
07	Interrupt Vector not defined	
15	RAM-check	
31	DMOS-Clock Handler sequence (DCW-Timing)	
Bootloader CRASH	ROM checksum error	

Should one of the above-mentioned errors occur, the system must be disconnected from power supply and the ES 200 control unit has to be programmed again.



The system cannot be updated via infrared device.