

SPEC SHEET FOR P/N: 104827

DWG # 104827

last update: 5-11-11

***NOT TO BE PRINTED AS PART OF INSTRUCTION***

PAPER MATERIAL & COLOR:

SHEETS: ALL: 20 LB, WHITE

PRINT COLOR: BLACK

PAGE SIZE & ORIENTATION:

ALL SHEETS 8½ X 11, PORTRAIT

STAPLE LOCATION & QUANTITY:

TOP LEFT CORNER, 1 ONLY

SPECIAL INSTRUCTIONS: PRINT ON FRONT AND BACK

Detex Corporation, 302 Detex Drive, New Braunfels, Texas 78130-3045  
(830)-629-2900 / 1-800-729-3839 / Fax (830)-620-6711  
E-MAIL: detex @ detex.com INTERNET: www.detex.com

## AO19 MS Sedco UDC1000 Controller Instructions

# UDC1000



**READ ALL INSTRUCTIONS CAREFULLY**  
**Contact Detex Corporation with all Technical Support Questions:**  
**1-800-729-3839 ext. 2**

# CONTENTS

UDC1000 Module Description .....	Page 1
Synchronizing Dual Operators .....	Page 2
104707 SYNC Cable.....	Page 2
Control Function Descriptions.....	Page 3
Electric Lock for Single Doors.....	Page 4
Electric Locks for Simultaneous Doors .....	Page 4
Signal and Sensor Connector.....	Page 4-5
Input Power Connector .....	Page 5
Motor Connector .....	Page 5
Option Switches .....	Page 5
UDC1000 Wiring Diagram Example .....	Page 6
Set Up—Adjustment Procedure.....	Page 7-9
Appendix A.....	Page 10-12



**NOTE:** The UDC1000 should be installed/serviced by an AAADM certified service technician. The service technician should be familiar with the latest ANSI A156.19 standards and all applicable local codes.



**WARNING:** NEVER sacrifice the safe operation of the automatic door for an incomplete installation or solution. Call the factory for technical support.

## Technical Support: 1-800-729-3839 ext. 2

### UDC1000 MODULE DESCRIPTION - CONNECTOR PINOUTS

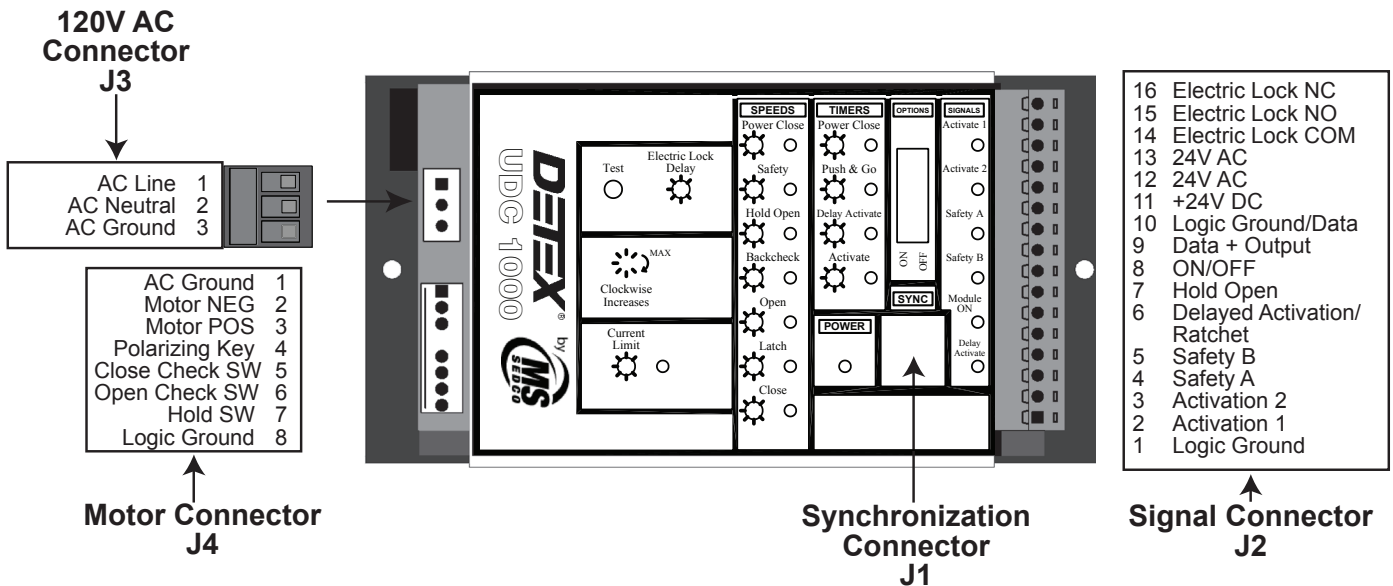

# SYNCHRONIZATION/UDC1000-Sync

**NOTE:** This section is for use with simultaneous pair operators only. For single operator installation, refer to page 4, "SIGNAL AND SENSOR CONNECTOR—J2".

## SYNCHRONIZATION / 104707 SYNC CABLE

This connector and cable assembly is used to synchronize two controls together for simultaneous pair door operators.

**NOTE:** When using the sync cable (Detex P/N 104707) for simultaneous pair controls, the adjustment to the speed potentiometers must be adjusted separately on each control.

For simultaneous pair door operators, plug in the synchronization cable as shown below. When using the SYNC cable, sensors and control switches can be wired to either control. All inputs are shared between the two controls using the sync cable, with the exception of the Delayed Activation inputs. When the "Delayed Activation Timer" expires, an activation signal is sent to the secondary control.

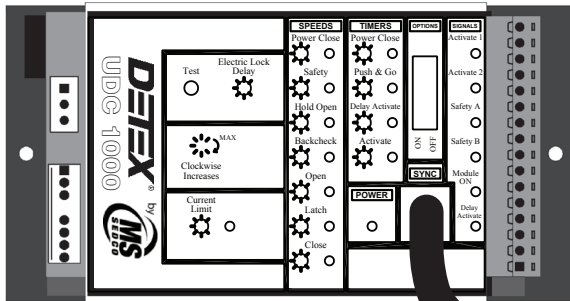

- 16 Electric Lock NC
- 15 Electric Lock NO
- 14 Electric Lock COM
- 13 24V AC
- 12 24V AC
- 11 +24V DC
- 10 Logic Ground/Data
- 9 Data + Output
- 8 ON/OFF
- 7 Hold Open
- 6 Delayed Activation/Ratchet
- 5 Safety B
- 4 Safety A
- 3 Activation 2
- 2 Activation 1
- 1 Logic Ground

### PRIMARY CONTROLLER

Set the "Activate Timer" and "Push & Go Timer" pots to the value needed.

### SECONDARY CONTROLLER



Important: Set the "Activate Timer" and "Push & Go Timer" pots to the maximum value (Fully clockwise) for the secondary controller.

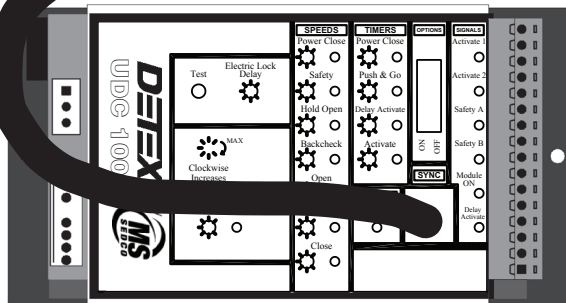

- 16 Electric Lock NC
- 15 Electric Lock NO
- 14 Electric Lock COM
- 13 24V AC
- 12 24V AC
- 11 +24V DC
- 10 Logic Ground/Data
- 9 Data + Output
- 8 ON/OFF
- 7 Hold Open
- 6 Delayed Activation/Ratchet
- 5 Safety B
- 4 Safety A
- 3 Activation 2
- 2 Activation 1
- 1 Logic Ground

## Control Function Descriptions

**TEST:** button to cycle test operator

**Caution:** To avoid damage, do not over rotate or use excessive force to turn potentiometers!

**CURRENT LIMIT Potentiometer:** adjusts the amount of current allowed for the motor to draw before shutting off for 10 seconds.

**ELECTRIC LOCK DELAY Potentiometer:** adjusts the time delay from activation input to the start of opening cycle

### SPEED POTENTIOMETERS

**CLOSE Potentiometer:** adjusts close speed from full open to last 10%. (Latch)

**LATCH Potentiometer:** adjusts the speed of the last 10% of closing

**OPEN Potentiometer:** adjusts the speed of opening from start to 80% open. (Backcheck)

**BACKCHECK Potentiometer:** adjusts the speed from 80% open to full open

**HOLD OPEN Potentiometer:** adjusts the amount of power required to hold door open

**SAFETY Potentiometer:** adjusts the open speed after a safety B signal to ground has occurred

**POWER CLOSE Potentiometer:** adjusts the force required to close the door from Latch-check to full close

### TIMER POTENTIOMETERS

**ACTIVATE Potentiometer:** adjusts the time of the opening cycle from release of an Activation 1 or 2 signal to ground, release of the Test Button or time out of a delayed activation signal to ground

**DELAY ACTIVATE Potentiometer:** adjusts the time of delay from a Delayed Activation signal to ground to start opening cycle

**PUSH & GO Potentiometer:** adjusts cycle time of an activation created from manually pushing the door open

**POWER CLOSE Potentiometer:** adjusts the time required to power close a door from Latch-check to full close

### LEDs

**POWER LED:** indicates that the 115 VAC connections have been connected to the control

**DELAY ACTIVATE LED:** indicates a delayed activation to ground (#6 to #1 or #2) is occurring

**MODULE ON LED:** indicates a signal from on/off to ground (#8 to #10 or #1) is occurring. (Toggle switch in ON position)

**SAFETY B LED:** indicates a signal from safety B to ground (#5 to #1 or #10) is occurring

**SAFETY A LED:** indicates a signal from safety A to ground (#4 to #1 or #10) is occurring

**ACTIVATION 2 LED:** indicates a signal from Activation 2 to ground (#3 to #1 or #10) is occurring

**ACTIVATION 1 LED:** indicates a signal from Activation 1 (#2 to #1 or #10) is occurring

**CURRENT LIMIT LED:** indicates the motor exceeded the allowed current limit defined by the current limit pot

# UDC1000 Universal Swing Door Control

## ELECTRIC LOCK FOR SINGLE DOORS

Wire the electric lock to the controller (refer to wiring diagram, page 6) and set Option Switch #3 to ON.

## ELECTRIC LOCK(S) FOR SIMULTANEOUS PAIR DOORS

For one control to activate the electric lock(s), wire the electric lock(s) to one control. Set option #3 to ON and adjust electric lock delay for that control only. Wire the activation signal(s) to the control that is wired to the electric lock.

For two controls to activate two electric locks (to keep the electric locks independent), wire the first electric lock to the first control, the second electric lock to the second control. Set option #3 to ON and adjust electric lock delay time on both controls.

## SIGNAL AND SENSOR CONNECTOR—J2

PIN	SIGNAL	DESCRIPTION
J2.16	Electric Lock Switch (Normally Closed)	This connection is the normally closed (NC) to drive an electric lock (active when electric lock option is set to ON).
J2.15	Electric Lock Switch (Normally Open)	This connection is the normally open (NO) to drive an electric lock (active when electric lock option is set to ON).
J2.14	Electric Lock Switch (Common)	This connection is the common to drive an electric lock (active when electric lock option is set to ON).
J2.13	(24V AC)	AC power (300mA Max.)
J2.12	(24V AC)	AC power (300mA Max.)
J2.11	(+24V DC)	DC power (300mA Max.)
J2.10	Logic Ground/Data-	Ground reference for signals and power.
J2.9	Data+	This is a signal output for sensor which requires door status information. <ul style="list-style-type: none"> <li>•When door is closed, data output is 0V.</li> <li>•When door is in the opening cycle, data output is 12V.</li> <li>•When door is closing (in motion), data output is 8V.</li> </ul>
J2.8	ON/OFF	Connecting this signal to ground (moving the 3-Position switch to ON) will enable the control. Moving the 3-Position switch to OFF will disable the control.
J2.7	Hold Open	Connecting this signal to ground (moving the 3-Position switch to the Hold Open position) will cause the door to open and hold open, if no current fault due to an obstruction is present.
J2.6	Delayed Activation/ Ratchet	This function is controlled by Option Switch 8 which is discussed on Page 5 of this manual. If the option switch is set to OFF (Delayed Activation), connecting this terminal to ground will start the delayed activation timer. When the timer expires the activation is generated. This function is used for door sequencing. If the option switch is set to ON (Ratchet Relay), connecting this signal to ground will initiate an activation signal. The activation signal will remain constant until another signal to ground occurs.
J2.5	Safety B	When the door is fully closed, this signal to ground will prevent an activation. During the opening cycle, the door will go to safety speed when this signal is to ground. During the closing cycle, the door will go to a very slow speed when this signal is to ground. When the door is fully open (with lockout option OFF), this signal to ground will prevent the door from entering the closing cycle.
J2.4	Safety A	When the door is fully closed, this signal to ground will prevent an activation. When the door is fully open, this signal to ground will prevent the door from entering the closing cycle.
J2.3	Activation 2	This signal is active when the door is in the closing cycle before latch, if the control is in ON mode (ON/OFF must be to ground) and no current fault is present. This signal to ground will cause the door to re-open. This signal is deactivated at latch and until a signal to ground at pin #1 has occurred. Manual use of the door will not enable this input.

# UDC1000 Universal Swing Door Control

- J2.2.....Activation 1 ..... This signal to ground will activate the operator. If the control is in ON mode (ON/OFF must be to ground) and no current fault is present.
- J2.1..... Logic Ground ..... Ground reference for signals and power.

## INPUT POWER CONNECTION (120V AC INPUT CONNECTOR)—J3

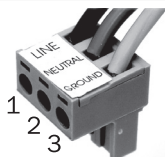

- | PIN ..... | SIGNAL DEFINITION             |
|-----------|-------------------------------|
| J3.1..... | AC Line (120V AC, 3A Max.)    |
| J3.2..... | AC Neutral (120V AC, 3A Max.) |
| J3.3..... | AC Ground                     |

## MOTOR CONNECTOR—J4

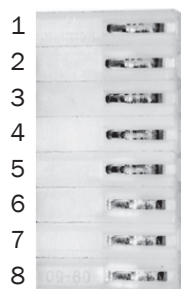

- | PIN ..... | SIGNAL.....             | DEFINITION  |
|-----------|-------------------------|---|
| J4.1..... | Motor AC Ground .....   | Used to ground motor body, when applicable.   |
| J4.2..... | Motor NEG (-) .....     | Goes to negative of the motor.  |
| J4.3..... | Motor POS (+).....      | Goes to positive of the motor.  |
| J4.4..... | Polarizing Key (NC) ... | Used to polarize the connector.   |
| J4.5..... | Latch Check Switch ...  | During the closing cycle, the operator goes to latch speed when this signal is to ground.     |
| J4.6..... | Back Check Switch ....  | During the opening cycle, the operator goes to backcheck speed when this signal is to ground. |
| J4.7..... | Hold Switch .....       | During the opening cycle, the operator is forced to hold speed when this signal is to ground. |
| J4.8..... | Logic Ground .....      | Ground reference for signals.   |

## OPTION SWITCHES

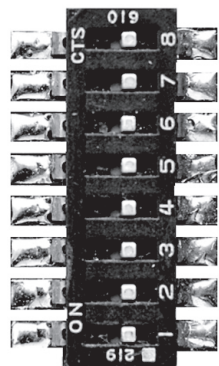

- | SWITCH ..... | DEFINITION   |
|--------------|--|
| 8 .....      | <b>Ratchet Relay:</b> If set to ON, an activation across pin #6 to 1 or 10, will cause the door to be opened and held open. When next activation occurs, the door will begin the closing cycle. Delayed activation is not available when this switch is ON.  |
| 7 .....      | <b>Door Seal:</b> If set to ON the operator will create a small resistance to prevent the door from opening 2 1/2 seconds after the door reaches the latch position.   |
| 6 .....      | <b>Push &amp; Go:</b> <i>For operator with a clutch. Use for low energy operator ONLY.</i> If set to ON, the operator is activated when the door is manually pushed outside the latch zone.  |
| 5 .....      | <b>Reverse on Obstruction:</b> If set to ON, during a closing cycle, if the door stalls before the latch position, a reactivation is generated.  |
| 4 .....      | <b>Power Close:</b> If set to ON, a reverse power is applied 2 1/2 seconds after the door reaches the latch position.  |
| 3 .....      | <b>Electric Lock:</b> If set to ON, an adjustable delay (0-1 1/2 sec.) is added prior to door activation, allowing the electric lock to unlock. <b>*Adjust the delay via the Electric Lock Delay Pot.</b> NOTE: The electric lock circuit should shunt back EMF. If it does not, a diode should be added to a DC electric lock circuit or a MOV should be added to an AC electric lock circuit to shunt the EMF. |
| 2 .....      | <b>Lockout (Safety B):</b> If this switch is ON, Safety B is ignored at and during back check.   |
| 1 .....      | <b>Push &amp; Go:</b> <i>For operator without a clutch. Use for low energy operator ONLY.</i> If set to ON, the operator is activated when the door is manually pushed.  |

**NOTE:** When the option switches are changed, the controller may not register the changes until the device is cycled.



# UDC1000 Universal Swing Door Control

## UDC1000—WIRING DIAGRAM EXAMPLE

Detex Corporation  
For Technical Service Call:  
1-800-729-3839

120VAC  
Inline Filter Kit  
P/N 104764-X

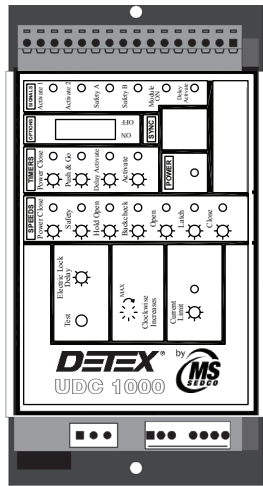
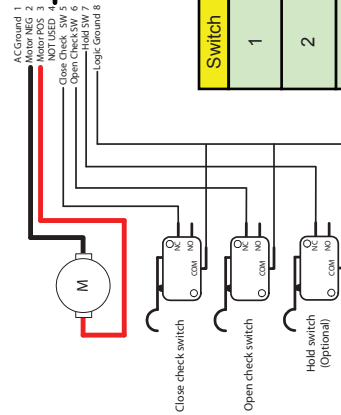

Option DIP Switch Definition  
See note for strike settings

Switch	Option Definition
1	<b>Push &amp; Go - For operator without a clutch</b> (Use for handicap operator ONLY) If this switch is set to "ON", the operator is activated when the door is manually pushed.
2	<b>Latchout</b> <b>Disable Safety B at backcheck</b> If this switch is set to "ON", Safety B is disabled at and during backcheck.
3	<b>Electric Lock</b> If this switch is set to "ON", a small delay is added prior to the door opening to allow to unlock the electric lock.
4	<b>Power Close</b> If this switch is set to "ON", a reverse voltage is applied when the door stalls in the latch area.
5	<b>Reverse on obstruction</b> If this switch is set to "ON", during a closing cycle, if the door stalls before the latch area, a re-activation is generated.
6	<b>Push &amp; Go - For operator with a clutch</b> (Use for handicap operator ONLY) If this switch is set to "ON", the operator is activated when the door is pushed outside the latch area.
7	<b>Door Seal (Power Close option must be set to "ON")</b> If this switch is set to "ON", the operator will create a small resistance to prevent the door to open by a small pressure.
8	<b>Ratchet Relay</b> If set to on, a contact across pins 6 & 1 or 10, will cause the door will be opened and HELD OPEN. When next activation occurs the door will begin the closing cycle. Delayed activation is not available when the switch is "ON".

### Low Energy Settings

**OPEN SPEED:** Door should open at a slow smooth pace (5 seconds or more), and stop without impact.

**HOLD OPEN:** Door must remain fully open for a minimum of 5 seconds before beginning to close.

**CLOSE SPEED:** Door should close at a slow, smooth pace (5 or more seconds), and stop without impact

DC (Fail-Secure) Strike Wiring Hookups  
Note: Set dip switch #3 to ON

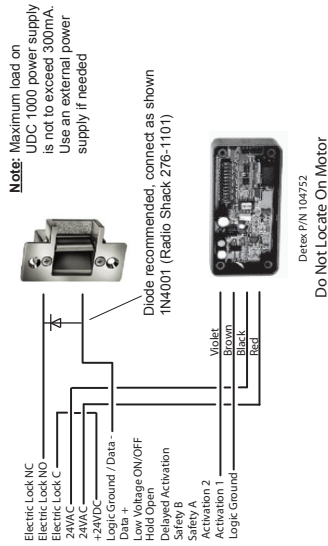

Do Not Locate On Motor

AC (Fail Secure) Strike Wiring Hookups  
Note: Set dip switch #3 to ON

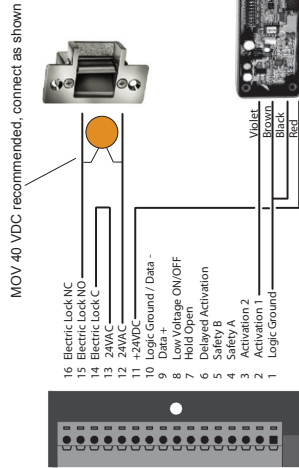

Do Not Locate On Motor

# UDC1000 Universal Swing Door Control

## UDC1000 SET UP — ADJUSTMENT PROCEDURE

Before applying power to the operator, make all necessary connections (Refer to the wiring diagrams on page 5 of this manual).

### 1. INSTALLATION CHECK

Before any adjustment can be made the following check must be performed:

- 1- First the arm must be properly connected to the door leaf
- 2- The power must be connected and the Toggle switch in the ON position
- 3- The door leaf must be fully closed

Examine the Door Control. The control board must have three lights illuminated; POWER, MODULE ON and LATCH.

If the POWER light is not on, review 110 connection and source of power supply.

If the MODULE ON light is not on, inspect the toggle switch to be sure it is in the ON position. Inspect wiring and connections. Be sure the green 16 pin terminal block is securely in place.

If the LATCH light is out and the CLOSE light is on, manually open the door leaf until it is stopped by internal stop. If the door over opens and the arm rotates well beyond 80 degrees refer back to arm installation directions and be sure that the operator motor has fully turned before assembling arm to shaft. If the door stops at desired opening and arm stops at approximately 80 degrees, an adjustment to the cam will need to be made.

The LATCH and BACKCHECK are controlled via the cam on top of the gearbox.

Access is thru the top of the operator case directly above the gearbox. Using a 1/8th inch Allen wrench, loosen the screw that holds the cam in place. Rotate cam in the closing rotation direction until the CLOSE light goes out and the LATCH light comes on. Holding the cam in place, gently retighten the holding screw.

### **CAUTION: DO NOT OVER TIGHTEN, AS THAT WILL DAMAGE THE CAM.**

Test the LATCH position by manually opening the door leaf until you see LATCH light go out and the CLOSE light comes on. This should be approximately 4 inches from Jamb. Fine tune adjustment as necessary.

If the light fails to work, call for factory assistance.

### 2. ADJUSTMENTS

All potentiometers (pots) are at minimum values when turned fully counter-clockwise and are at maximum values when turned fully clockwise. A speed or timer pot is active when the corresponding light (LED) is lit.

Before beginning adjustments, set the following:

1. Activation timer pot to 1/4 turn clockwise from the minimum.
2. Current limit pot to the maximum - fully clockwise.
3. Close the latch speed pot to minimum - fully counter-clockwise.
4. Set all option switches to the "OFF" position. If an electric lock is used, set option #3 to the "ON" position.

# UDC1000 Universal Swing Door Control

## UDC1000 SET UP — ADJUSTMENT PROCEDURE (continued)

### 2.1 BASIC ADJUSTMENTS

All adjustments to the control are designed to meet ANSI/BHMA requirements. For further information on ANSI/BHMA specifications, please refer to Appendix A at the end of this manual.



**NOTE:** When using the sync cable (104707) for simultaneous controls, the adjustments to force and speed potentiometers must be adjusted separately on each control.

Activate the operator by pushing the test button.

1. Adjust "OPEN SPEED" pot so that the door arrives at back-check in no greater than 3 seconds for Handicap applications.
2. Adjust "BACK-CHECK SPEED" pot so that door creeps to final open in no less than 2 seconds for Handicap applications.
3. Adjust "HOLD OPEN SPEED" pot so that the power is just enough to hold door at full open without drifting closed.
4. Adjust "ACTIVATE TIMER" pot so that the door remains in the full open position for no less than 5 seconds for Handicap applications.
5. Adjust "CURRENT LIMIT" pot so that the door stops when it meets an obstruction during the opening cycle. Cycle test several times.
6. Adjust "CLOSE SPEED" pot so that the door closes no faster than 4 seconds to latch-check.
7. Adjust "LATCH SPEED" pot so that door closes the final 10 degrees without slamming.

### 2.2 OTHER ADJUSTMENTS AND OPTIONS

#### SAFETY SPEED

If a door mounted safety sensor is used, follow these steps to adjust the safety speed:

1. Ensure that the sensor is connected to Safety B input. **NOTE:** If Option Switch #2 is ON, Safety B input will be ignored at and during back check.
2. Push the test button to generate an Open Cycle.
3. During the open cycle (before backcheck), generate a safety signal.
4. With the safety signal present, adjust the safety speed trimmer to achieve a creep or a stall motion of the door.



**NOTE:** If the safety sensor is a header mount type (Sensor will detect the door when the door swings within its' pattern), "SAFETY A" input must be used for that sensor.

#### PUSH & GO

If Push & Go is needed, set the option to the "ON" position. The UDC1000 has two types of Push & Go:

1. Option #1: For operators without a clutch (Activated when the door is manually pushed).
2. Option #6: For operators with a clutch. Operator must have a close check (latch) switch to use this option (Activated when the door is manually pushed outside the latch zone).

After the proper Push & Go option has been selected, manually push the door open. The controller will detect the door movement and will generate an open cycle. Adjust the Push & Go timer pot for the desired opening time for a Push & Go activity.

## **UDC1000 Universal Swing Door Control**

### **UDC1000 SET UP — ADJUSTMENT PROCEDURE (continued)**

#### **POWER CLOSE TIMER & SPEED POT**

If power close is needed, set option #4 to the "ON" position. Follow these steps to adjust the length and strength of the power close:

1. Push the test button to generate an opening cycle.
2. The door enters the closing cycle and 2.5 seconds after it reaches Latch, Power Close activates. Adjust the power close speed pot for the desired strength.
3. Generate another opening cycle. When power close activates, set the length of the power close by adjusting the power close timer pot (1 to 10 seconds).

#### **DOOR SEAL**

If a positive pressure causes the door to slightly open, the door seal option #7 can be used. Setting this option to the "ON" position will cause a small resistance to aid in keeping the door closed.

#### **REVERSE ON OBSTRUCTION**

Set option #5 to the "ON" position to activate the reverse on obstruction option. When the door stalls between backcheck and the latch position, the controller will generate an activation cycle.

#### **DELAYED ACTIVATION TIMER**

The activation signal of another operator can be connected to the delayed activation input to create door sequence operation. When used, adjust the delayed activation timer pot to create the proper delay.

**Need Technical Support?**

**1-800-729-3839 ext. 2**

# UDC1000 Universal Swing Door Control

## APPENDIX A: ANSI/BHMA specifications for Low Energy Operators (from ANSI/BHMA A156.19)

### 3. REQUIREMENTS FOR POWER ASSIST DOORS

- 3.1 **Activation** Power assist doors shall operate only by pushing or pulling the door. An activating means is permitted to be used to put the door in the power assist mode.
- 3.2 **Opening** If the opening force on the door is released, the door shall come to a stop and either immediately begin to close or begin to close after a predetermined time.
- 3.3 **Time Delay** Not required.
- 3.4 **Closing** Door shall close from 90 degrees to 10 degrees from closed, in 3 seconds or longer as required in Table 1. Doors shall close from 10 degrees to fully closed in not less than 1.5 seconds.
- 3.5 **Force and Kinetic Energy** The force required to prevent a door from fully closing shall not exceed 15 lbf (67 N) measured 1 inch (25 mm) from the latch edge of the door at any point in the closing cycle. Doors shall open with a manual force not to exceed 15 lbf (67 N) to release a latch if equipped with a latch, 30 lbf (133 N) to set the door in motion, and 15 lbf (67 N) to fully open the door. The forces shall be applied at 1 inch (25 mm) from the latch edge of the door.
- 3.6 **Signage** See Section 6 for signage.

### 4. REQUIREMENTS FOR LOW ENERGY POWER OPERATED DOORS

- 4.1 **Activation** The operator shall be activated by a knowing act.
- 4.2 **Opening** Doors shall open from closed to back check, or 80 degrees whichever occurs first, in 3 seconds or longer as required in Table 1. Backcheck shall not occur before 60 degrees opening. Total opening time to 90 degrees shall be as in Table 2. If the door opens more than 90 degrees, it shall continue at the same rate as backcheck speed.
- 4.3 **Time Delay** When powered open, the door shall remain at the fully open position for not less than 5 seconds. Exception: When push-pull activation is used, the door shall remain at the fully open position for not less than 3 seconds.
- 4.4 **Closing** Doors shall close from 90 degrees to 10 degrees in 3 seconds or longer as required in Table 1. Doors shall close from 10 degrees to fully closed in not less than 1.5 seconds.
- 4.5 **Force and Kinetic Energy** The force required to prevent a stopped door from opening or closing shall not exceed 15 lbf (67 N) measured 1 inch (25 mm) from the latch edge of the door at any point during opening or closing. The kinetic energy of a door in motion shall not exceed 1.25 lbf-ft (1.69 Nm). Table 1 provides minimum times for various widths and weights of doors for obtaining results complying with this kinetic energy. Doors shall open with a manual force not to exceed 15 lbf (67 N) to release a latch, if equipped with a latch, 30 lbf (133 N) to set the door in motion, and 15 lbf (67 N) to fully open the door. The forces shall be applied at 1 inch (25 mm) from the latch edge of the door.
- 4.6 **Signage** See Section 6 for signage.

### 5. CYCLE TESTS

- 5.1 Low Energy Power Operated, and Power Assist doors shall be cycle tested for 300,000 cycles.
- 5.2 Use the widest and heaviest test specimen recommended for use by the manufacturer. Narrower or lighter doors of the same configurations shall then be considered to meet the cycle test requirements.
- 5.3 Use the requirements in Table 1 to determine opening and closing times. Open the door to a  $90 \pm 5$  degree open position and close the door to the  $0 + 2$  degree closed position using appropriate equipment. One opening and closing constitutes one cycle. In the case of Power Assist doors, use

## UDC1000 Universal Swing Door Control

**APPENDIX A (continued):**  
**ANSI/BHMA specifications for Low Energy Operators**  
**(from ANSI/BHMA A156.19)**

### 5. CYCLE TESTS (continued)

an actuator exerting an equivalent force equal to a 15 lbf (67 N) measured at 1 inch (25 mm) from the latch edge of the door applied in the opening direction and allow the closing device furnished to close the door.

- 5.4 At the conclusion of the cycle test, the doors shall operate in accordance with requirements of Table 1, and the actual opening and closing time shall be within -10% to +20% of their respective values at the commencement of the test.

**TABLE 1**  
**Minimum Opening Time to Back Check or 80 degrees (whichever occurs first) and**  
**Minimum Closing Time from 90 degrees to Latch Check or 10 degrees (whichever occurs first)**

"D" Door Leaf Width - Inches (mm)	"W" Door Weight in Pounds (kg)				
	100 (45.4)	125 (56.7)	150 (68.0)	175 (79.4)	200 (90.7)
*30 (762)	3.0	3.0	3.0	3.0	3.5
36 (914)	3.0	3.5	3.5	4.0	4.0
42 (1067)	3.5	4.0	4.0	4.5	4.5
48 (1219)	4.0	4.5	4.5	5.0	5.5
Matrix values are in seconds					

\* Check applicable Building Codes for clear width requirements in Means of Egress

Doors of other weights and widths can be calculated using the formula:

$$T = D / 133 \text{ in US Units}$$

$$T = D / 2260 \text{ in SI (metric) units}$$

Where:

T = Time, seconds

D = Door width, inches (mm)

W = Door weight, lbs. (kg)

The values for "T" time have been rounded up to the nearest half second. These values are based on a kinetic energy of 1.25 lbf-ft.

**TABLE 2**  
**Total Opening Time to 90 Degrees**

Backcheck at 60 degrees	Backcheck at 70 degrees	Backcheck at 80 degrees
Table 1 plus 2 seconds	Table 1 plus 1.5 seconds	Table 1 plus 1 second
If the door opens more than 90 degrees, it shall continue at the same rate as backcheck speed.		

NOTE: To determine maximum times from close to full open, the operator shall be adjusted as shown in the chart. Back check occurring at a point between positions in Table 2 shall use the lowest setting. For example, if the backcheck occurs at 75 degrees, the full open shall be the time shown in Table 1 plus 1.5 seconds.

## UDC1000 Universal Swing Door Control

### APPENDIX A (continued): ANSI/BHMA specifications for Low Energy Operators (from ANSI/BHMA A156.19)

#### 6. SIGNAGE

- 6.1 Doors shall be equipped with signage visible from either side of the door, instructing the user as to the operation and function of the door. The signs shall be mounted 50" ± 12" (1270 mm ± 305 mm) from the floor to the center line of the sign. The letters shall be 5/8 inch (16 mm) high minimum.
- 6.2 Consistent with section 2.2.1 of ANSI Z535.4 - 2002 the "signage and warnings" guidelines of A156.19 are recognized, industry-specific standards that predate the adoption of Z535.4 and are not replaced by the standards set forth therein.

#### 6.3 Power Assist Doors

- 6.3.1 When a separate wall switch is used to initiate power assist, the doors shall be provided with signs on both sides of the door with the message "EASY OPEN DOOR - ACTIVATE SWITCH THEN OPEN DOOR". The lettering shall be white and the background shall be blue.
- 6.3.2 When remote devices, and/or pushing or pulling the door are used to initiate power assist, the doors shall be provided with the messages "EASY OPEN DOOR - PUSH TO OPERATE" on the push side of the door and "EASY OPEN DOOR - PULL TO OPERATE" on the pull side of the door. The lettering shall be white and the background shall be blue.

#### 6.4 Low Energy Doors

- 6.4.1 All low energy doors shall be marked with signage visible from both sides of the door, with the words "AUTOMATIC CAUTION DOOR" (See Figure 1). The sign shall be a minimum of 6 inches (152 mm) in diameter with black lettering on a yellow background. Additional information may be included. Additionally one or both of the following knowing act signs shall be applied:
- 6.4.2 When a Knowing Act Switch is used to initiate the operation of the door operator, the doors shall be provided with signs on each side of the door where the switch is located, with the message "ACTIVATE SWITCH TO OPERATE". The lettering shall be white and the background shall be blue.
- 6.4.3 When push/pull is used to initiate the operation of the door operator, the doors shall be provided with the message "PUSH TO OPERATE" on the push side of the door and "PULL TO OPERATE" on the pull side of the door. The lettering shall be white and the background shall be blue.



Figure 1

#### Knowing Act Switch Mounting Guideline

Preferably located from one to five feet from the door, but no more than twelve feet away, the switch on the swing side should not be blocked by the door when in the open position. Switches should not be located where use puts the person in the swing path of the door. The switch should be mounted in a location where the person has full sight of the door. Mounting height of 34" to 48" off the floor (or per specific codes requirements).