

# DOR-O-MATIC<sup>®</sup>

## Mid-Swing<sup>®</sup>

Instructions for installing and using  
the

84590-9XX Microcomputer Control Box  
with the

83800-9XX Motor Gear Box Operator

### Factory Authorized Door Leaf Size & Weight:

<u>Type</u>	<u>Width per Leaf</u>	<u>Max. Weight per Leaf</u>
Single Door	36" to 48"	200 lb
Sim. Pair	30" to 48"	200 lb.

## **DOR - O - MATIC**<sup>®</sup>

7350 W. Wilson Ave.

Harwood Heights, IL 60656

Toll Free: 1-800-543-4635

In Illinois: 708-867-7400

Admin. FAX: 708-867-0421

Engineering FAX: 708-867-1177

Printed in U.S.A.

Booklet No.

84590-984

Price: \$15.00

REV. 4/21/93



**A. GENERAL**

The #84590-9XX Universal Control Box is a continuation of Dor-O-Matic's policy to continually upgrade and improve our products for service and dependability using the latest computer technology.

**B. FEATURES**

The #84590 looks and operates very similar to the old #84540 but with the following improvements:

1. All #84590's have a safty stop feature so if the door encounters an object as it opens, the door will stop and then close gently by spring force.
2. All #84590's have a selector switch on the exterior of the control box so that the unit can be installed with PUSH-N-GO or without PUSH-N-GO depending on the mode selected by the installer.
3. All #84590's have two rotary switches that permit field selection of the desired function and latch position of the door. The function and latch positions available are:

SETTING	FUNCTION SELECTOR DIAL	SETTING	LATCH SELECTOR DIAL
0	1 Second Hold-Open on PUSH-N-GO operation; Variable 2-30 second Hold-Open with remote switch	0	Zero Latch
1	Same variable 2-30 second Hold-Open on PUSH-N-GO and remote switch	1	3° Latch
2	DOR-O-MATIC Electric Lock	2	7° Latch
3	Alternate Action	3	10° Latch
4	SUPER-NOVA Safety Slow	4	Standard Latch (13°)
5	SUPER-NOVA Safety Stop	5	17° Latch
6	Automatic Reversing with Setting "0"	6	20° Latch
7	Soecial Control	7	23° Latch
8-9	Unassigned	8-9	Unassigned
A-F	Unassigned	A-F	Unassigned

The Function Selector Dial and Latch Selector Dial are shipped at Function "0" and Latch "4"; these are the most common and standard settings for the control box.

**NOTE:** Power to the box should be turned off & back on each time either switch position is changed, to assure proper re-programming of the control box.

A drawing illustrating the control box switches and functions appears in FIG. #1, page 2.



#84590  
MICRO PROCESSOR  
CONTROL BOX

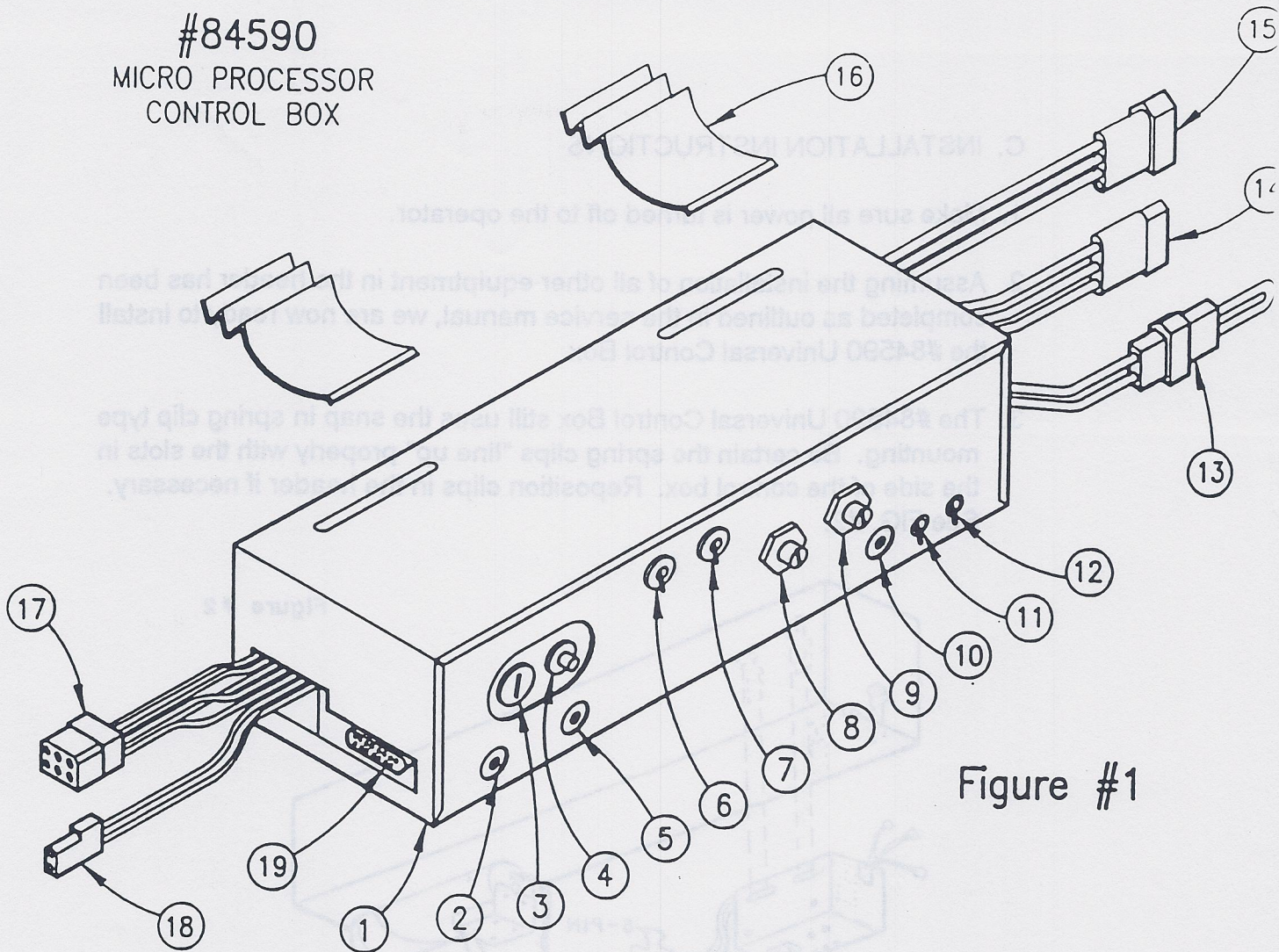

Figure #1

- |  |  |
|--|--|
| ① CONTROL BOX # 84570-900 115 Volt<br>CONTROL BOX # 84570-991 230 Volt | ⑪ OPENING SPEED ADJUSTMENT<br>(#1 FAST, #2 MEDIUM, #3 SLOW)    |
| ② FUNCTION SELECTOR DIAL   | ⑫ BACKCHECK SPEED ADJUSTMENT<br>(#1 - ONE DOOR, #2 - TWO DOOR) |
| ③ FUSE, 3 Amp I.B. for 115 Volt<br>FUSE, 3 Amp I.B. for 230 Volt       | ⑬ 2 PIN FEMALE, BREAKAWAY                                      |
| ④ CIRCUIT BREAKER, 2 Amp   | ⑭ 3 PIN FEMALE, ACTIVATION                                     |
| ⑤ LATCH SELECTOR DIAL  | ⑮ 4 PIN MALE, POWER INPUT                                      |
| ⑥ PUSH-N-GO ON/OFF SWITCH  | ⑯ CONTROL BOX MOUNTING CLIPS (4 REQUIRED)                      |
| ⑦ POWER BOOST ON/OFF SWITCH<br>(Non-Functional with Mid-Swing)         | ⑰ 6 PIN FEMALE, TO MASTER OPERATOR                             |
| ⑧ CLOSING SPEED ADJUSTMENT - FOR MASTER UNIT                           | ⑱ 2 PIN FEMALE, TO SLAVE OPERATOR                              |
| ⑨ CLOSING SPEED ADJUSTMENT - FOR SLAVE UNIT                            | ⑲ LOGIC TERMINAL - USED FOR<br>"SUPER NOVA"                    |
| ⑩ TIME DELAY ADJUSTMENT - 1/2 sec. to 30 sec.                          |  |



### C. INSTALLATION INSTRUCTIONS

1. Make sure all power is turned off to the operator.
2. Assuming the installation of all other equipment in the header has been completed as outlined in the service manual, we are now ready to install the #84590 Universal Control Box.
3. The #84590 Universal Control Box still uses the snap in spring clip type mounting. Be certain the spring clips "line up" properly with the slots in the side of the control box. Reposition clips in the header if necessary. See FIG. #2.

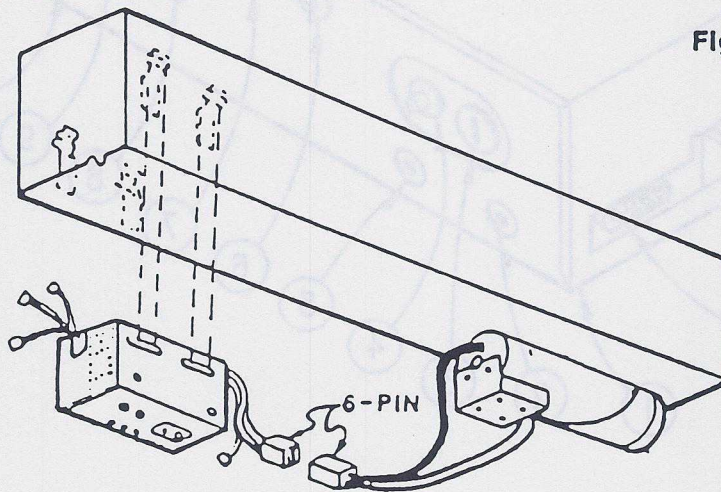

Figure #2

### D. WIRE CONNECTIONS

1. See FIG. #3 for complete wire connection details.
2. CAUTION: Whenever a molex plug is joined or separated, DO NOT push or pull on the wires. This may cause a wire or terminal to be pulled loose, causing a malfunction.
3. If installing simultaneous pairs of doors, connect the 2 conductor (red & black) wires to the Slave operator using the #81274-900 adapter cable, (automatically shipped with simultaneous pair of doors). If installing a single door the (red & black) wires from the control box are not used.
4. Connect orange wires to the breakaway switch for in-swing center pivoted doors or install orange jumper plug if breakaway switch(es) is (are) not used.
5. Connect all activation and safety devices to the (yellow, blue & gray) wires only. (See FIG. #4)



# DUK-W-M, LL

Mid - Swing

## WIRE CONNECTION DETAIL

PUSH-N-GO SINGLE OR SIMULTANEOUS PAIR OF DOORS

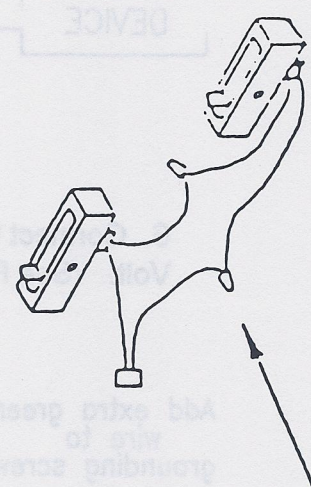
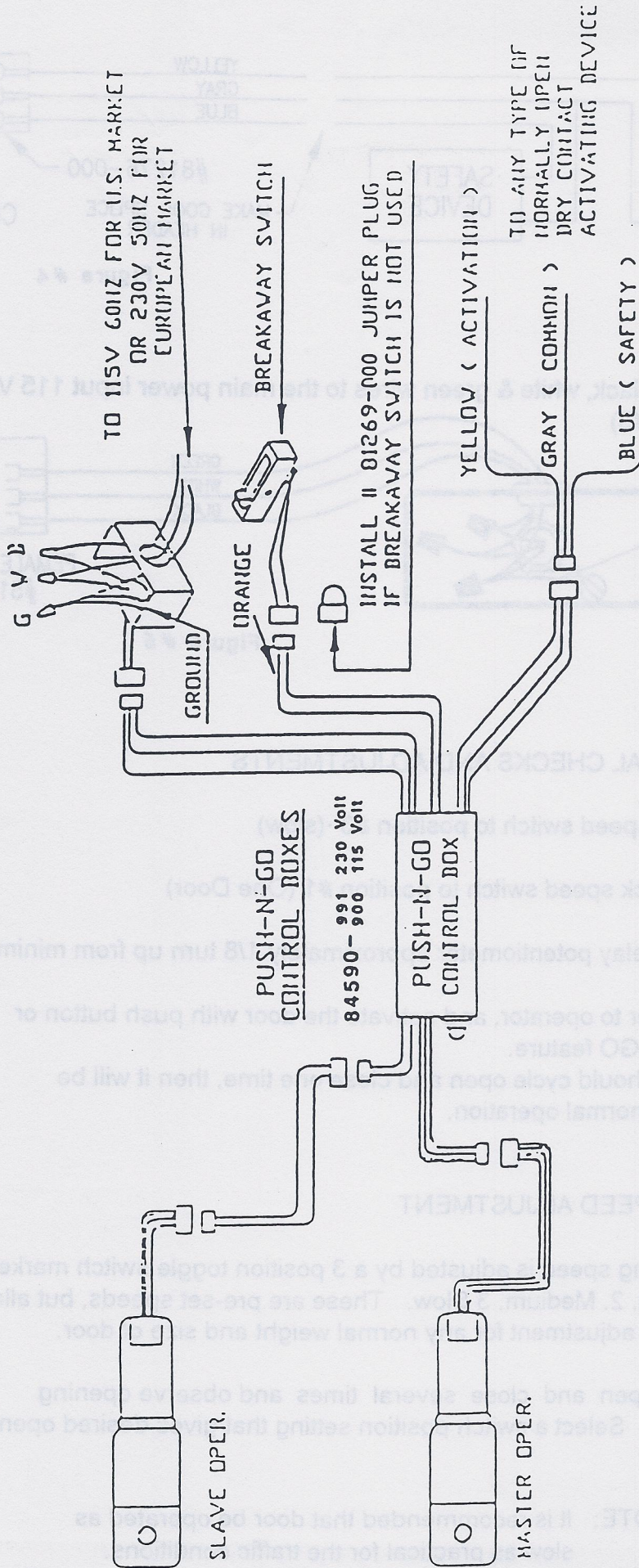

DOUBLE BREAKAWAY SWITCH WIRING DETAIL  
FOR USE ON SIMULTANEOUS PAIR OF DOORS.

INSTALLER MUST CUT & RECONNECT  
ORANGE WIRES FROM BOTH BREAKAWAY  
SWITCHES TO ONE MOLEX PLUG  
EXACTLY AS SHOWN

Figure # 3



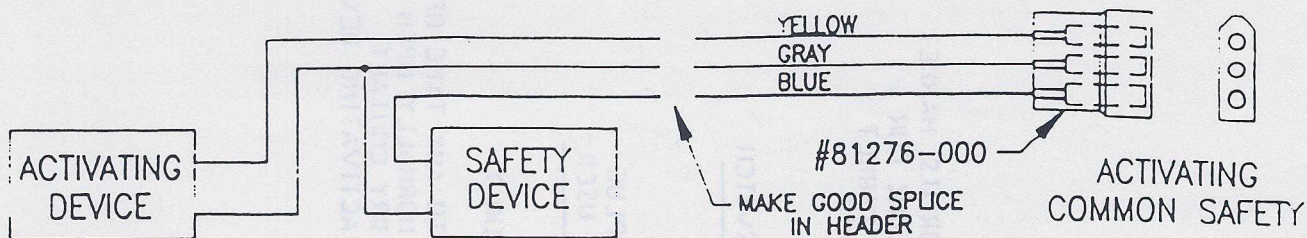

Figure #4

6. Connect the black, white & green wires to the main power input 115 Volt or 230 Volt. (See FIG. #5)

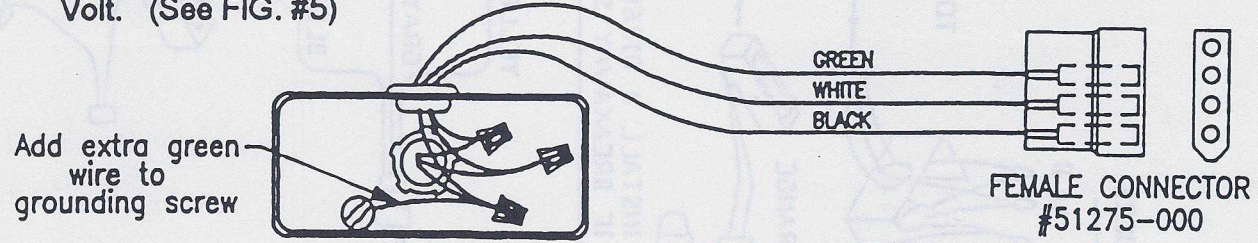

Figure #5

F. OPERATIONAL CHECKS AND ADJUSTMENTS

1. Set opening speed switch to position #3 (slow)
2. Set back check speed switch to position #1 (One Door)
3. Adjust time delay potentiometer approximately 1/8 turn up from minimum.
4. Turn on power to operator, and activate the door with push button or with Push-N-GO feature.
  - a. Door should cycle open and close one time, then it will be ready for normal operation.

5. OPENING SPEED ADJUSTMENT

- a. Opening speed is adjusted by a 3 position toggle switch marked, 1. Fast. 2. Medium. 3 Slow. These are pre-set speeds, but allow proper adjustment for any normal weight and size of door.
- b. Cycle door open and close several times and observe opening speed. Select a switch position setting that gives desired opening speed.

NOTE: It is recommended that door be operated as slow as practical for the traffic conditions.



## 6. BACK CHECK SPEED ADJUSTMENT

- a. The back check speed is controlled by a 2 position toggle switch marked #1-One Door and #2-Two Doors.
- b. For any size single door, switch should be set in position #1.
- c. For a simultaneous pair of doors, switch should be set in position #2.
- d. Backcheck location is not field adjustable. It is factory set at approximately 80 degrees of door opening.

## 7. LATCHING SPEED AND LOCATION ADJUSTMENT

- a. Latching speed is factory set and has no field adjustment.
- b. Latch location is field adjustable from 0 to 23 degrees thru use of the latch rotary switch located on the control box.

## 8. CLOSING SPEED ADJUSTMENT

- a. You will notice there are two closing speed adjustment potentiometers, one marked "MASTER", and one marked "SLAVE". This is so that on simultaneous pairs of doors each leaf can be adjusted separately allowing both doors to close fully at the same time.
- b. On a single door, only the MASTER potentiometer is used to adjust closing speed. The Slave control has no effect
- c. Continue to cycle door open and close while making adjustments.

## 9. TIME DELAY ADJUSTMENT

- a. To meet ANSI and UL standards the total time delay, must include any delay in the activation and safety devices, MUST be adjusted to hold the door open for a MINIMUM of 1 1/2 seconds after both activation and safety zones are clear.
- b. Adjustment is made with a small screwdriver inserted through the hole in the control box housing marked "TIME DELAY". Clockwise rotation of the potentiometer increases time delay period. The total adjustment range on the control box itself is 1/2 to 30 seconds of time delay.



## 10. OPERATIONAL WALK-THROUGH TEST

**NOTE:** It is assumed that during the installation process any problems would have been found and corrected before this point. However, it is recommended that a complete walk-through test now be performed.

- a. **Opening and holding function:** Normally walk up to the door and activate. The door should open smoothly and silently to the back check point where it should slow down rapidly and drift into full 90 degree open position without slamming.
- b. Continue activation to insure that the door will not time out and close while being activated.
- c. After activation is discontinued the door should time out at the pre-set time delay period. Door should close quietly and smoothly to the latch point, where it rapidly slows down and slowly drifts into the fully closed position without slamming.

## 11. RELEASE OF THE MID-SWING SYSTEM FOR SERVICE

- a. Remove all tools and installation equipment and clean any debris from the vicinity of the door.
- b. Install all safety, traffic control, and instruction decals to door as required.

**This is very important! Failure to do this leaves the installer LIABLE for any accident that might occur. THIS MUST BE DONE!**

- c. Verbally explain the proper operation of the door system to the owner or person in charge.
- d. Install the dress plates in the header.