

# DOR-O-MATIC®

## ELECTRO-MECHANICAL

### 70590 ASTRO-SLIDE II

INSTALLATION  
AND  
SERVICE  
MANUAL

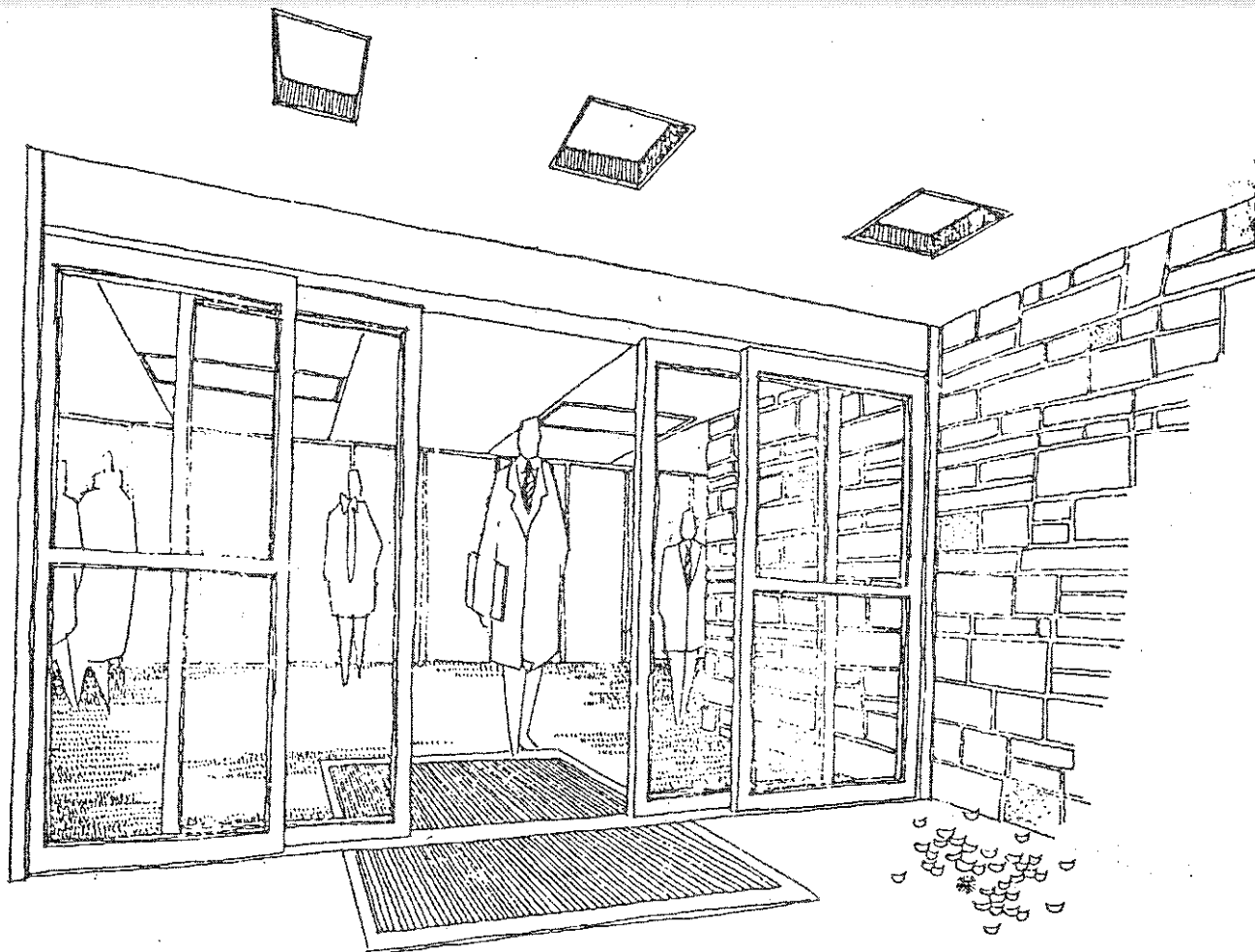

### NOTICE

### DOOR SIZE AND WEIGHT REQUIREMENTS

TYPE	DOOR OPENING		MAX. WEIGHT TOTAL LOAD
	MIN.	MAX.	
BI-PARTING PAIR	48"	72"	150 LBS.
SINGLE	36"	44"	150 LBS.

## DOR-O-MATIC

Division of Republic Industries, Inc.

7350 West Wilson Avenue, Chicago, Illinois 60656 (312) 867-7400

England: Dor-O-Matic C.B. Ltd., Thames House, Wellington Square, London S.E. 18

Canada: Dor-O-Matic of Canada, Toronto

8100-984

PRICE: \$15.00

## CONTENTS

Equipment furnished by DOR-O-MATIC for complete package.	2				
Description.	3	4	Carpet switch lead wires in door jamb.	5	
Operation.	3	5	Removing pulley and bracket.	5	
Check structure at entrance opening.	3	6	Installation of pulley bracket.	6	
<b>INSTALLATION.</b>	<b>4</b>	7	Transom assembly details.	6	
General.	4	8	Securing door frame.	7	
Assembly of door frame (and optional transom)	5	9	Transom Glass Stop installation details.	7	
Door frame installation.	7	10	Carpet and threshold installation details (surface mtd.).	8	
Transom Glass Stop installation.	7	11	Carpet lead wire connections.	8	
Installation of Carpet and Threshold (surface mounted).	8	12	Alignment of sidelite panel pivots.	9	
Installation of recessed carpets and thresholds.	9	13	Carpet and threshold installation (recessed).	10	
Installation of sliding doors.	13	14	Recessed carpet frame installation details.	11	
Door activating devices.	14	15	Carpet installation (recessed).	11	
Motion detectors.		16	Sliding door installation details.	12	
Wall Push Plate, Model 1290A		17	Hanging door on rail.	13	
Floor switch, Model 1275A		18	Roller installation details.	13	
Installation of sidelite panels	14	19	Bottom door guide installation details.	13	
Installation of Glass Stops.	14	20	Anti-Riser adjustment.	13	
Installation of control box.	16	21	Sidelite panel installation details.	15	
Installation of Motor and Gear Train assembly.	16	22	Door sag adjustment.	15	
Installation of timing device (max 4-1/2 ft. doors).	17	23	Installation of control box.	16	
Installation of drive cable assembly.	17	24	Installation of motor and gear train assembly.	16	
Electrical connections.	18	25	Timing device assembly installation.	17	
Adjustments and operational checks:	18	26	Drive cable assembly installation details.	17	
A. Door positioning.		27	Electrical connections.	18	
B. Cam and switch positioning.		28	Cam positioning (rotating).	18	
C. Door speed and delay control.		29	"Back Check" stop cam adjustments.	19	
D. Operational checks.		30	"Open Door" stop cam adjustments.	19	
Putting the system into service.	20	31	"Latch" stop cam adjustments.	19	
Trouble shooting.	21	32	"Close Door" stop cam adjustments.	19	
		33	Switch arm positions.	19	
		34	Micro-switch locations.	20	
		35	Door speed and time delay controls.	20	
		36	Schematic diagram, Astro-Slide II door system.	23	
		37	Connections for switch cables and motor	24	

## ILLUSTRATIONS

<u>Figure No.</u>	<u>Title</u>	
1	Astro-Slide II sliding door installation.	3
2	Installation plan.	4
3	Header assembly details.	5

## EQUIPMENT FURNISHED BY DOR-O-MATIC FOR COMPLETE PACKAGE

### A. HEADER ASSEMBLY

The Header Assembly is shipped completely assembled with all components mounted in place except motor and controls.

The basic Header Assembly consists of:

- a) Header and Track
- b) Hinged interior cover
- c) Jamb mounting brackets
- d) All switches and wiring assemblies

### B. OPERATION and CONTROL

Operator and controls are shipped separately from the Header and installed after Header and Frame are installed.

### C. SIDE JAMBS

The Side Jambs furnished are fully prepared to accept mounting of the Header.

### D. THRESHOLD KIT

The Threshold Kit furnished contains all required threshold parts and floor guide to complement model number ordered.

### E. DOOR and CARRIER ASSEMBLY

The Door and Carrier Assembly is shipped com-

pletely assembled except for roller brackets, without glazing. The bottom door guide is shipped loose in a parts bag. Doors for standard units feature "limit arms" to prevent swing-out past 90 degrees.

### F. SIDELITE ASSEMBLY

The Sidelite Assembly is shipped completely assembled ready for hanging but without glazing. Sidelites for standard units feature "limit arms" to prevent swing-out past 90 degrees.

### G. LOCKS

Locks, if ordered as part of a complete package, are factory installed into the doors.

### H. CLOSERS IN DOORS and/or SIDELITES

Closers are assembled into doors and/or sidelites in place of "limit arms" when specified.

### I. INSTALLATION INSTRUCTIONS

### J. ACTIVATION SYSTEM: MATS, MOTION DETECTOR, & ETC.

ASTRO-SLIDE II  
AUTOMATIC SLIDING DOOR SYSTEMS  
ELECTRO MECHANICAL

DESCRIPTION

The Astro-Slide II is a fully automatic Sliding Door Entrance, which provides a full "width opening" and permits traffic flow in both directions. Both the door and the sidelite incorporate a breakaway feature which allows them to swing out in the direction of egress, in the event of a power failure or other emergency.

These sliding door systems are available in both SINGLE and BI-PARTING PAIR Models (see FIG. 1).

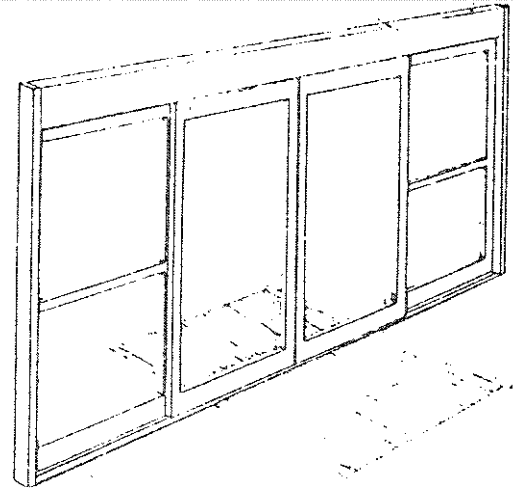
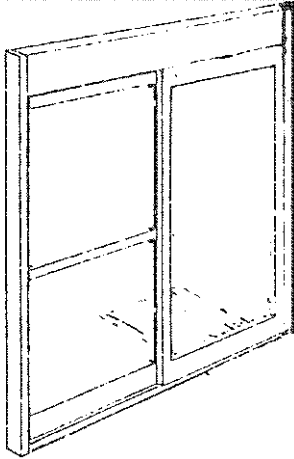

FIG. 1 Astro-Slide II sliding door installation.

The sliding action is provided by a permanent magnet D. C. motor and gearbox connected to the door with a chain and cable drive system. The sliding door is driven under power in both the opening and closing cycles and is under complete control at all time, as individual potentiometers independently control the opening speed, back check, hold open time delay period, closing speed and latching speed. Two micro-switch operational arrangements are available in these systems--one actuated by four rotating cams and the other by a single sliding cam.

In models with sliding cams the position of the door, where latching and back-check take effect, is determined by the placement of the limit switches controlling these functions. The exact placement of these switches is fully adjustable and determined by the weight and size of the doors. In models with rotating cams the door positions are determined by the settings of the cams in positions relative to each other. The positions of the switches are not adjustable.

Actuation of the doors is accomplished with carpets, motion detectors, push plates, pull chain, or several other types of available controls. Any normally open momentary contact switching devices rated at 1 amp 24 V. A. C. may be used to energize the activating circuit.

It should also be pointed out that any number or combination of normally open switching devices that will best serve the traffic requirements of a particular installation may be utilized by connecting them in parallel.

OPERATION

The activating circuit when energized will open the door. After the activating circuit has been de-energized an adjustable time delay will continue to

hold the door open for the preset time period. The door will then close. The activating circuit will instantly re-open the door from any position in the closing cycle. The "breakaway" feature, mentioned previously, is available with either controlled or uncontrolled swinging action. The controlled swing incorporates a hydraulically operated door closer, mounted in the top door rail. This limits the "swing open" action of the door to 90 degrees and automatically returns the door to the closed position after the breakout. The uncontrolled swing consists of a pivot in both the top and bottom of the door and a limit arm attached to the top of the door for limiting the door swing to 90 degrees. Once the door is broken away it will remain in this position until manually closed.

CHECK STRUCTURE AT ENTRANCE OPENING

- A) Check architectural prints and shop drawings for position of frame in structural opening.
- B) Check opening dimensions, allowing  $\frac{1}{4}$ " at each side and top so that frame may be plumbed and squared.
- C) Check floor level, jamb to jamb. It is very important that the floor for a sliding entrance be flat and level within  $\frac{1}{8}$ " across the entire width of the opening.

- D) Check floor surface. Surface must be flat and smooth where mats are to be installed. Carefully check for irregularities and, if necessary, ask the General Contractor to:
- 1) Relieve high spots at any point along the line of door travel which may restrict the movement of the sliding panel or the swing-out action of the breakaway panel.
  - 2) Fill low spots across the door opening which may cause voids in the bottom weathering or improper fit of mats to threshold. Keep in mind that the Header must be installed level from jamb to jamb.
- E) Check floor grades. If floor is ramped, the break in grade must occur at the outside edge of the threshold. Exterior ramp, if any, must slope away from entrance to allow panic breakaway of the door and to provide drainage on exterior units.

**CAUTION:** If recessed carpets are used or no threshold is to be installed, one-half inch ( $\frac{1}{2}$ " ) must be cut off the bottom of each jamb, or there will be 11/16" clearance under the door.

## INSTALLATION

### GENERAL

This manual covers installation of both BI-PARTING PAIR and SINGLE door Models of the ASTRO-SLIDE II, Sliding Door Systems.

Before proceeding with any stage of the installation, check the contents of the shipping containers against the bill of material to see that all necessary parts and material have been included. Also, be sure that the door size and model are correct for the required installation.

The hinged cover of the header must be installed toward the interior side of the building. The sliding direction determines the hand of the door. Direction of slide is determined from the fixed facia (exterior) side of the header. The hand of the panel is also determined from the fixed facia side of the header, (see FIG. 2).

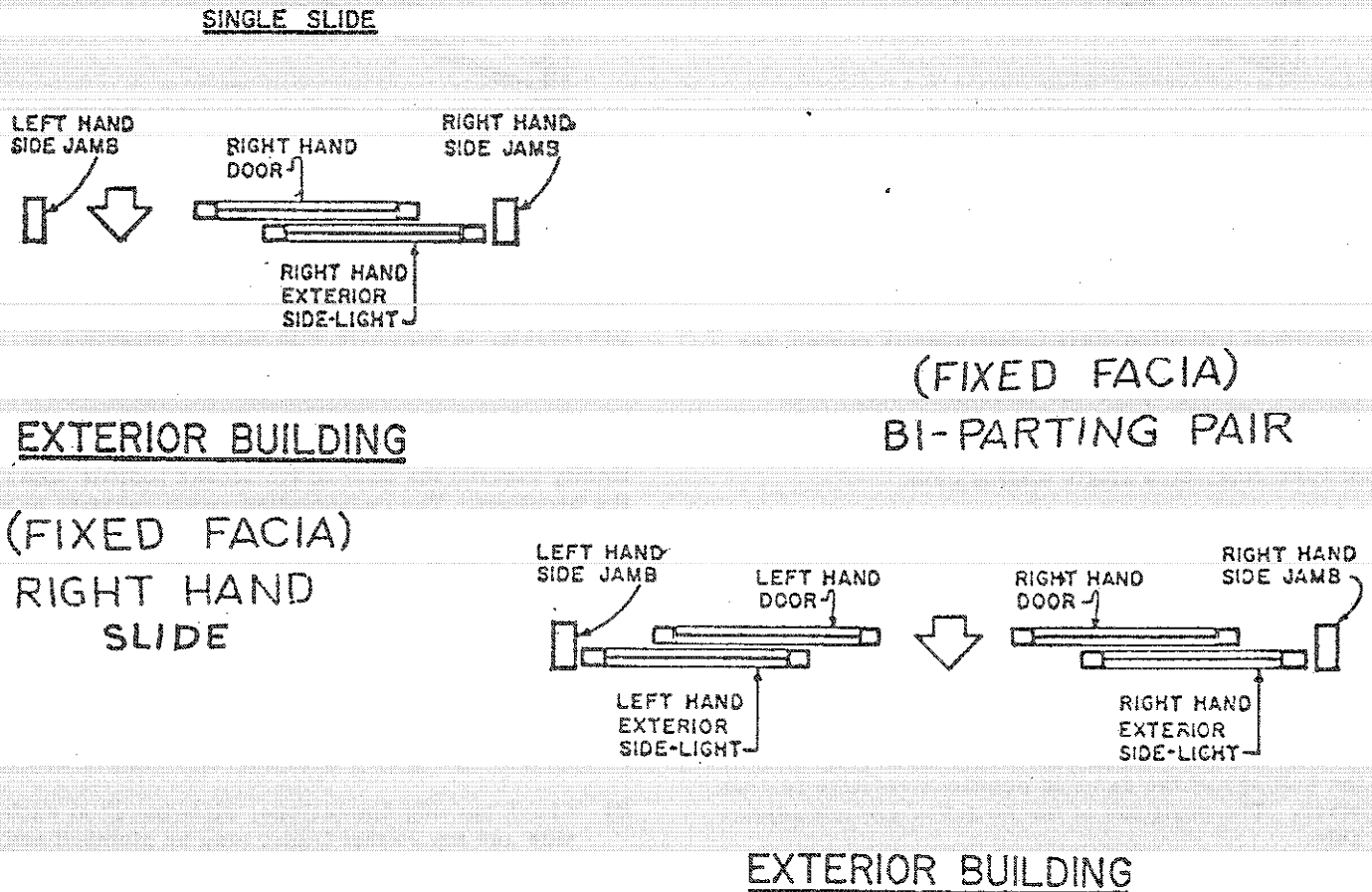

FIG. 2 Installation plan.

**ASSEMBLY OF DOOR FRAME (and OPTIONAL TRANSOM)**

1. Lay header on floor with open side up and placing a 2 x 4 wood block under each end, (see FIG. 3).
2. Remove the cover from the header by swinging it to a fully open position, unhooking the clips and lifting it off.

5. Remove the cable roller bracket from the L. H. end of header, (see FIG. 5).
  - a) Remove nut (a) from axel (b). Remove axel and pulley (c).

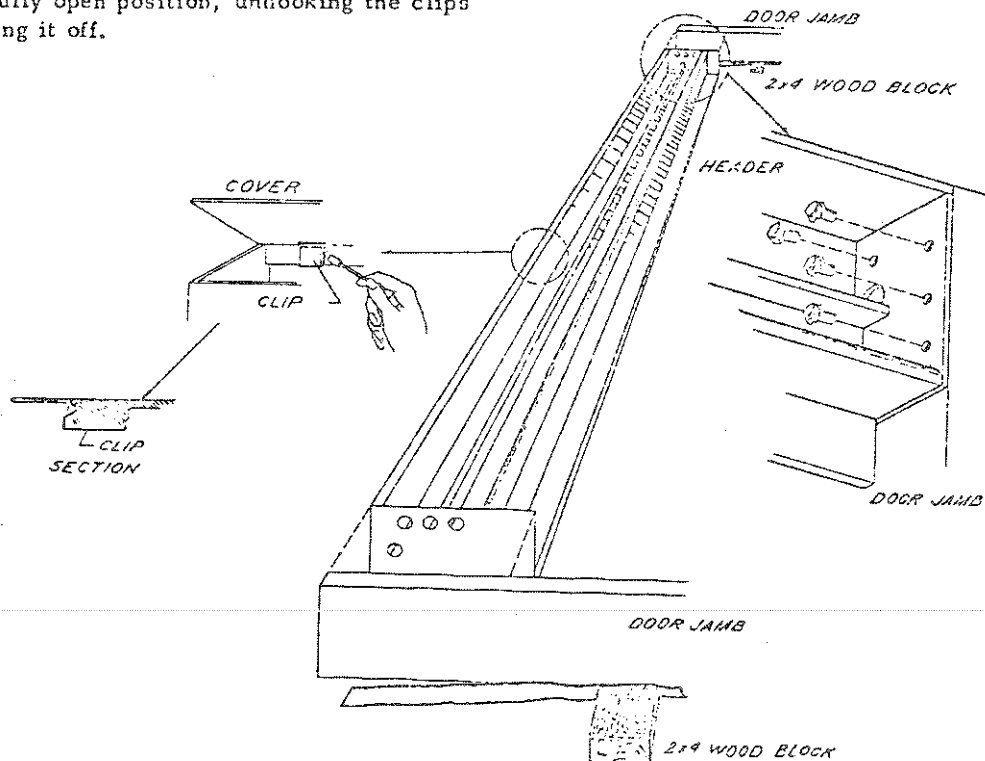

FIG. 3 Header assembly details.

3. Lay both jambs on the floor in proper relationship to assemble with header as shown in FIG. 3.
4. If carpets are to be installed cut a notch at the bottom end of the L. H. jamb, and install the low voltage mat wire as shown in FIG. 4. Disregard if other type activating device is used.

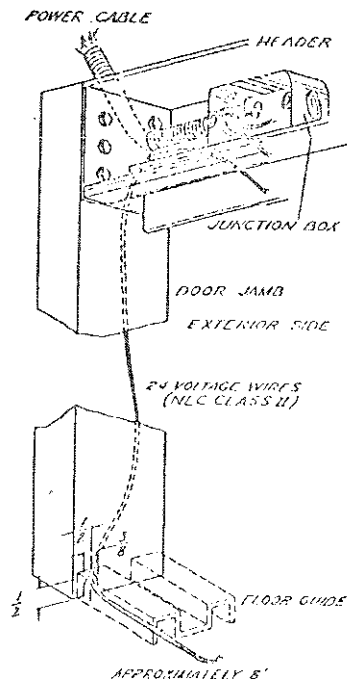

FIG. 4 Carpet switch lead wires in door jamb.

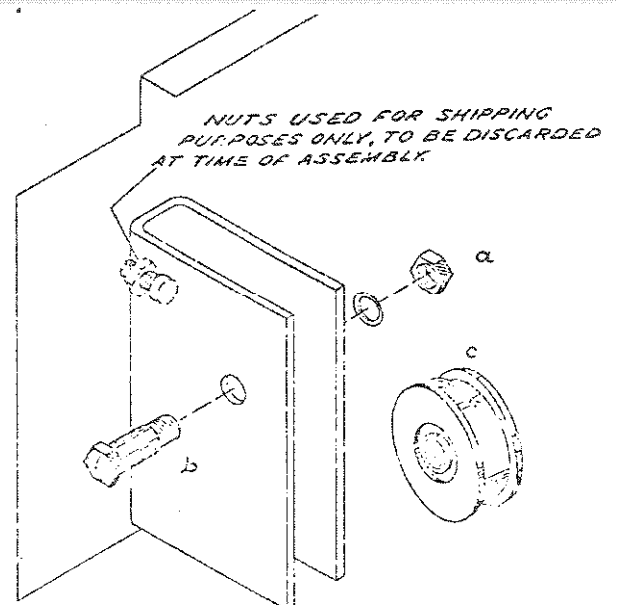

FIG. 5 Removing pulley and bracket.

- b) The bracket is held to the end plate for shipping purposes only. Remove screws and discard nuts. The screws will be used for replacing bracket.

6. Secure header in place with (4)  $\frac{1}{4}$ -20 H. H. C. S. Screws on the R. H. end and two  $\frac{1}{4}$ -20 H. H. C. S. on the L. H. end. Also install the cable pulley bracket with two  $\frac{1}{4}$ -20 S. H. C. S. as shown in FIG. 6.

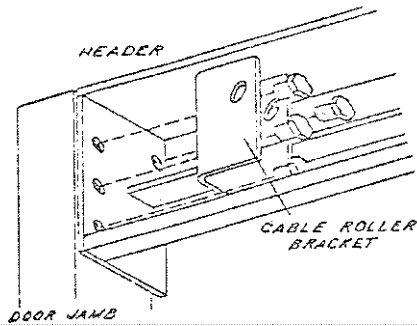

FIG. 6 Installation of pulley bracket.

**NOTE:** If transom is not to be installed, all nuts, bolts and screws must be tightened securely and steps 7 thru 10 disregarded.

7. As shown in FIG. 7, mount the angle bracket on the top side of the header, using two  $\frac{1}{4}$ -20 phillips head screws and two  $\frac{1}{4}$ -20 nuts. Be sure to use the bracket that has a round hole in the center slot and that it is positioned as shown in Detail A. Mount the other similar bracket on the underside of the horizontal transom tube. Install the other two brackets on the top ends of the door jambs with two  $\frac{1}{4}$ -20 screws and two  $\frac{1}{4}$ -20 nuts on each bracket.

8. Attach one end of the vertical transom tube to the bracket on the top side of the header with 8-32 flat head self-threading screws. The brackets must be inside of the tube. Attach the other end of the tube to the bracket on the bottom side of the horizontal transom tube. Attach the brackets at the top ends of the jambs to the horizontal transom tube, with two 8-32 self-threading screws on each bracket. The brackets must be inside the tube.

9. Turn a  $\frac{3}{8}$ -16" nut onto the threaded rod. Position it about 1 inch from the end. Insert the rod (end without nut first) through the hole in the top side of the horizontal tube and down through the hole in the top side of the header. Do not insert it through the bottom hole yet. Turn two more nuts onto the rod about two inches from the end. Insert the end of the rod through the bottom hole in the header. Tighten the nuts against the header. Tighten the nut in the horizontal transom tube.

10. Tighten all other nuts, bolts and screws securely. Check all corners of the frame for squareness.

11. The door frame is now ready for raising and setting into place.

**CAUTION**  
WHEN RAISING THE DOOR FRAME  
ASSEMBLY TAKE CARE TO PREVENT IT  
FROM TWISTING.

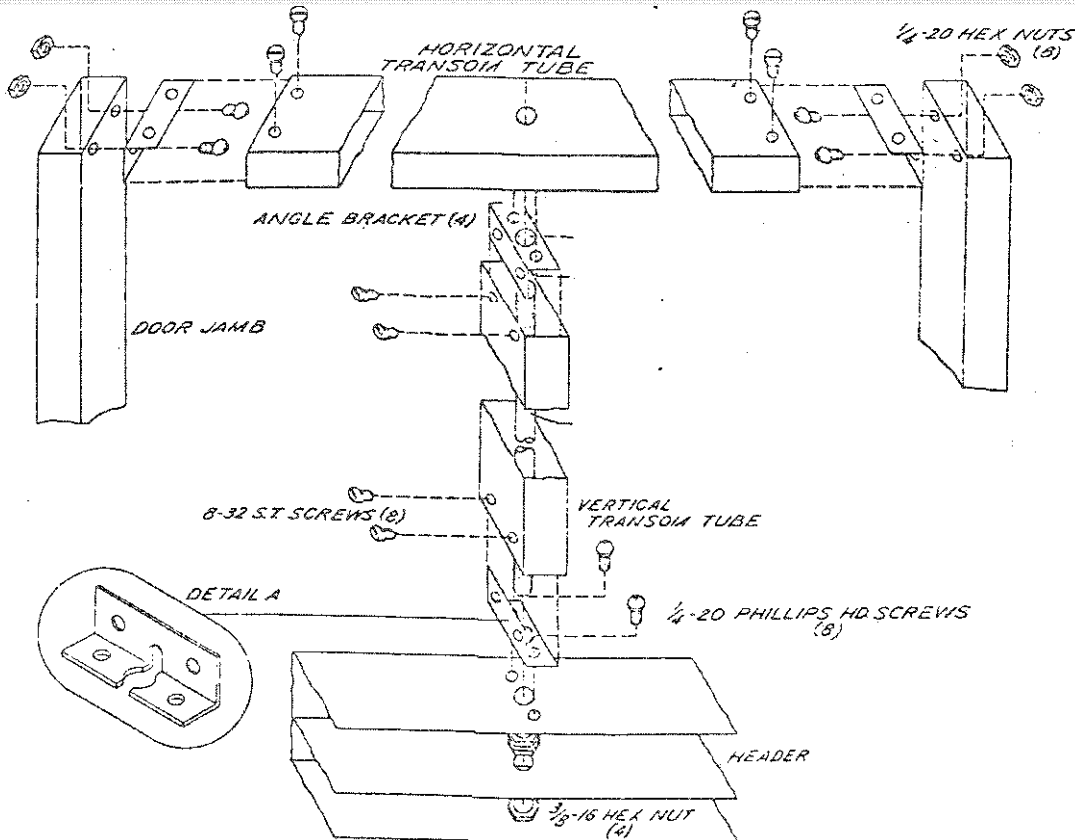

FIG. 7 Transom assembly details.

## DOOR FRAME INSTALLATION

1. After raising the assembled door frame, position it in the provided opening. There should be a minimum clearance of  $\frac{1}{4}$  inch around the top and sides as shown in FIG. 8.

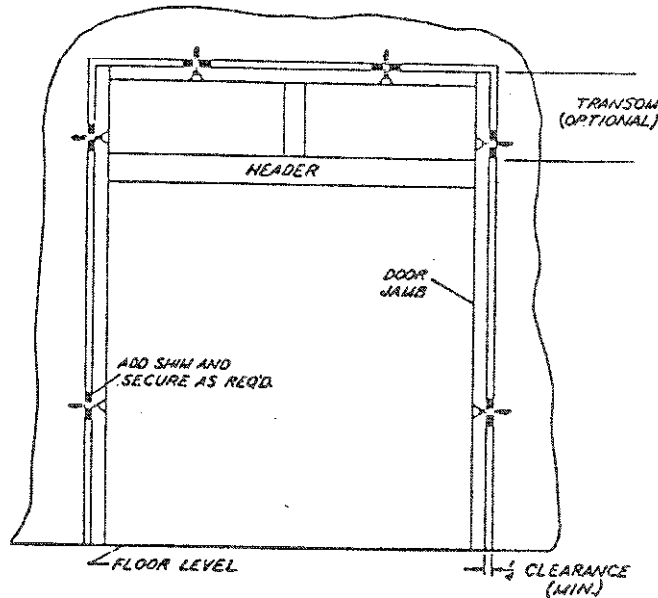
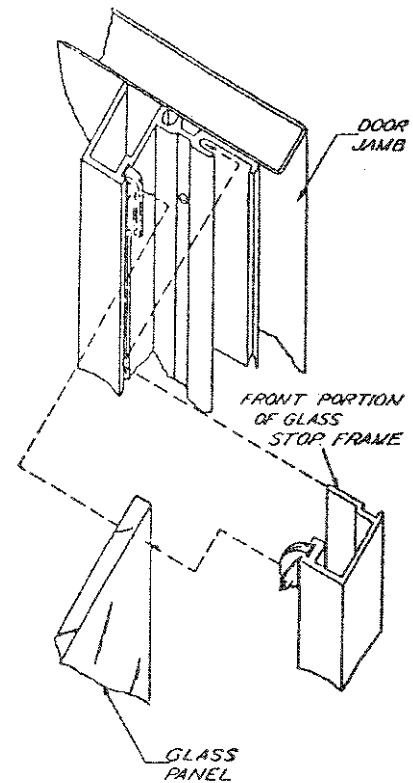

FIG. 8 Securing door frame.



**CAUTION:** It is recommended that the door frame remain attached to the hoisting equipment or be temporarily supported until secured in place.

2. Drill holes in the door jambs for the fasteners<sup>o</sup> required to secure the door frame in place. Flat head fasteners are recommended, for which the holes must be countersunk. It is also recommended that the fastener holes be drilled on the interior side of the frame.
3. Install the necessary shims around the top and sides of the frame to make it level and plumb.
4. Secure the frame to floor and to other points, as required. Detach the frame from the hoisting equipment or remove the temporary supports.

### TRANSOM GLASS STOP INSTALLATION (Optional)

1. If a transom is included in the door frame, install the glass stop frames as shown in FIG. 9. Use 8-32 flat head self threading screws, for which holes are provided in the glass stop frames.

**CAUTION:** The glazing material used throughout this installation must comply with ANSI Performance Standard Specification Z97.1-1972.

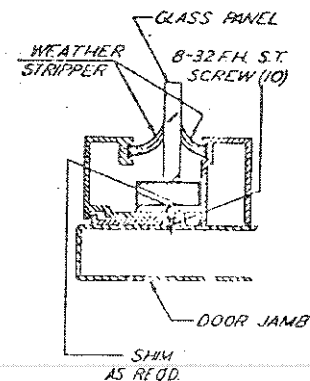

FIG. 9 Transom Glass Stop installation details.

2. The glass stop frames are constructed of snap-in tongue and groove arrangements shown in FIG. 9. Remove each of the tongue portions and install the glass panels. Replace the tongue portions. The weather stripping, shown in FIG. 9, must be flush up against the glass.

**INSTALLATION OF CARPET and THRESHOLD  
(SURFACE MOUNTED)**

1. After the door frame is secured in place, snap a chalk line between the two door jambs at the interior side of the door frame (see FIG. 10).

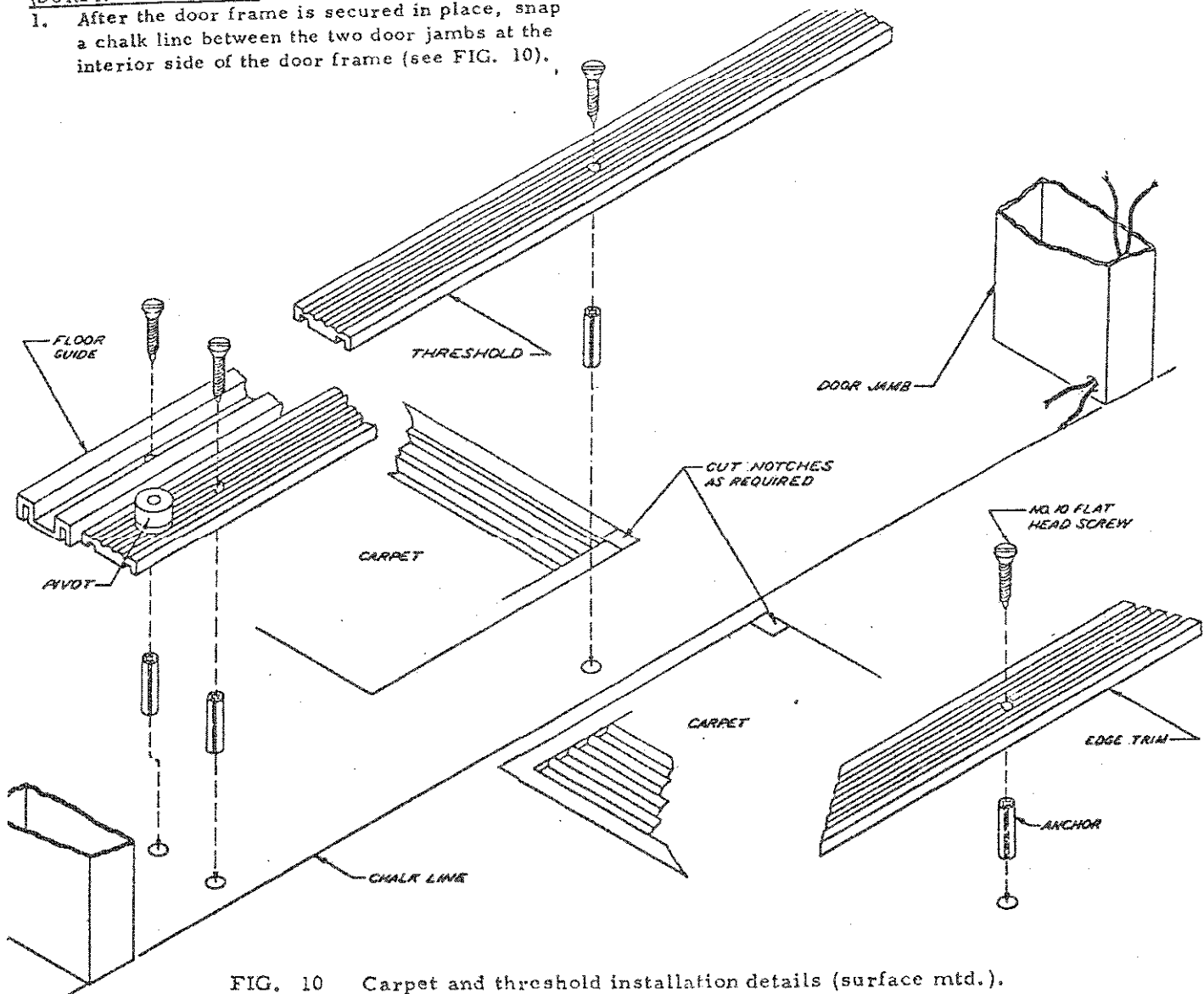

FIG. 10 Carpet and threshold installation details (surface mtd.).

2. Place each floor guide with one edge flush up against the chalk line and the edge against the door jamb. Use the holes in the floor guide to locate points on the floor underneath for drilling holes for the plastic inserts. Drill 5/16 inch holes, 1 inch deep at the located points. Tamp the plastic inserts into the holes and secure the floor guides to the floor, with the wires from the door jamb running through one of its grooves, as shown in FIG. 11. Use No. 10 sheet metal screws.

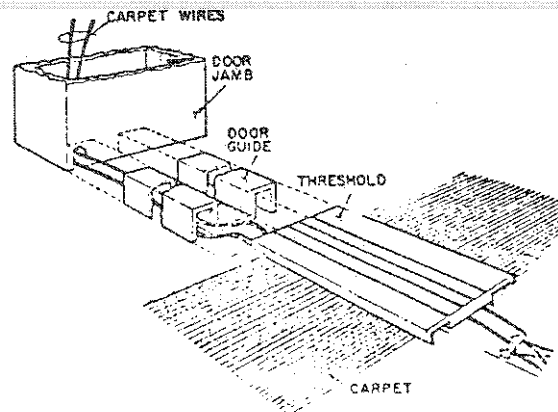

FIG. 11 Carpet lead wire connections.



3. Hang a plumb line from the retractable pivot in the header (see FIG. 12). Place the side-

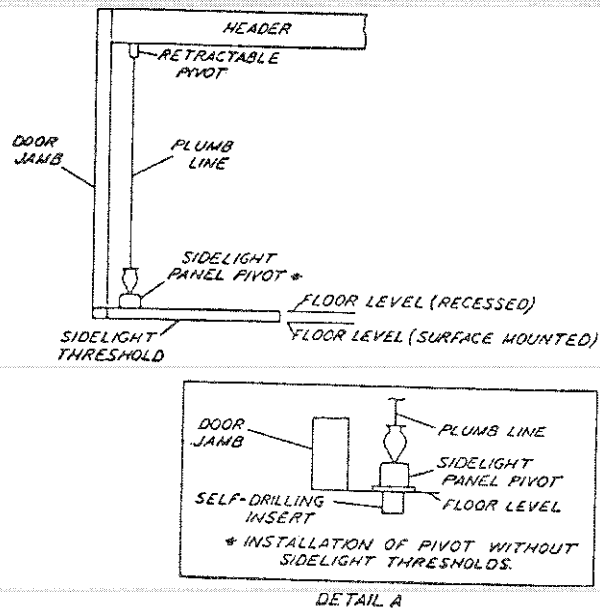

FIG. 12 Alignment of sidelite panel pivots.

lite threshold flush up against the door guide. The pivot must be directly under the plumb bob. Locate points for the plastic insert holes in the same manner as for the floor guide (described in the preceding paragraph). Drill the holes and tamp in the inserts. Install the sidelite panels with No. 10 sheet metal screws.

4. Place the center threshold between the floor guides with one edge flush with the chalk line. Locate points for the insert holes. Drill the holes and tamp in the inserts. Remove the center threshold.
5. Splice the carpet wires to the wires coming from the floor guides, with wire nuts.

**NOTE:** If other than carpet switches are to be installed, refer to the applicable instruction sheet.

6. Notch two corners of the carpets to fit around the thresholds, as required, (see FIG. 10). Move the carpets up against the sidelite thresholds. Install the center threshold with its edges inserted in the grooves in the carpet (see FIG. 10, Detail A). Secure the threshold with No. 10 sheet metal screws.

**CAUTION:** Be sure that the wires underneath the threshold are not pinched.

7. Position the edge trim around the carpets. Using the holes in the edge trim as a guide, locate the points for drilling 5/16 insert holes. Drill the holes and tamp in the inserts. Install the edge trim with No. 10 sheet metal screws.

#### INSTALLATION OF RECESSED CARPETS AND THRESHOLDS.

1. If the concrete floor is not poured, prior to erecting the Astro-Slide II Sliding Door system, it is recommended that recessed accommodations be made for the carpets and thresholds. Shore boxes of the proper size and depth may be set in place before pouring and removed after the concrete is set. If the floor is already poured, it will be necessary to cut these recesses in the floor. If sidelite thresholds are to be installed, the dimensions of the shore boxes should be slightly larger than the lengths and widths of the sidelite thresholds. This is to allow for alignment of the sidelite panel pivot with the retractable pivot in the header. If sidelite thresholds are not required disregard the following step.
2. Place the sidelite thresholds into the recesses provided for them with the pivots toward the door jambs, (see FIG. 13). Hang a plumb line from the retractable pivot in the header and align the threshold pivot with the plumb bob (see FIG. 12). Using the holes in the thresholds as a guide locate points underneath for drilling 5/16-holes about 1 inch deep. (see FIG. 13). Remove the thresholds and drill the holes. Tamp in the plastic inserts.
3. Find the location for the self drilling insert from the plumb bob. Mark the location. Turn the 1/4-20 cap screw into the insert. Clamp the screw head into a drill chuck and bore the insert into the floor until the top is flush with, or not more than 1/32-inch below the floor level. Remove the cap screw and use it to install the sidelite panel pivot.
4. Drill the holes for the floor guide insert in the same manner as for the sidelite thresholds. Drill the holes and tamp in the plastic inserts. Install the floor guides with No. 10 sheet metal screws. The wires from the door jamb must run through one of the grooves without being pinched.

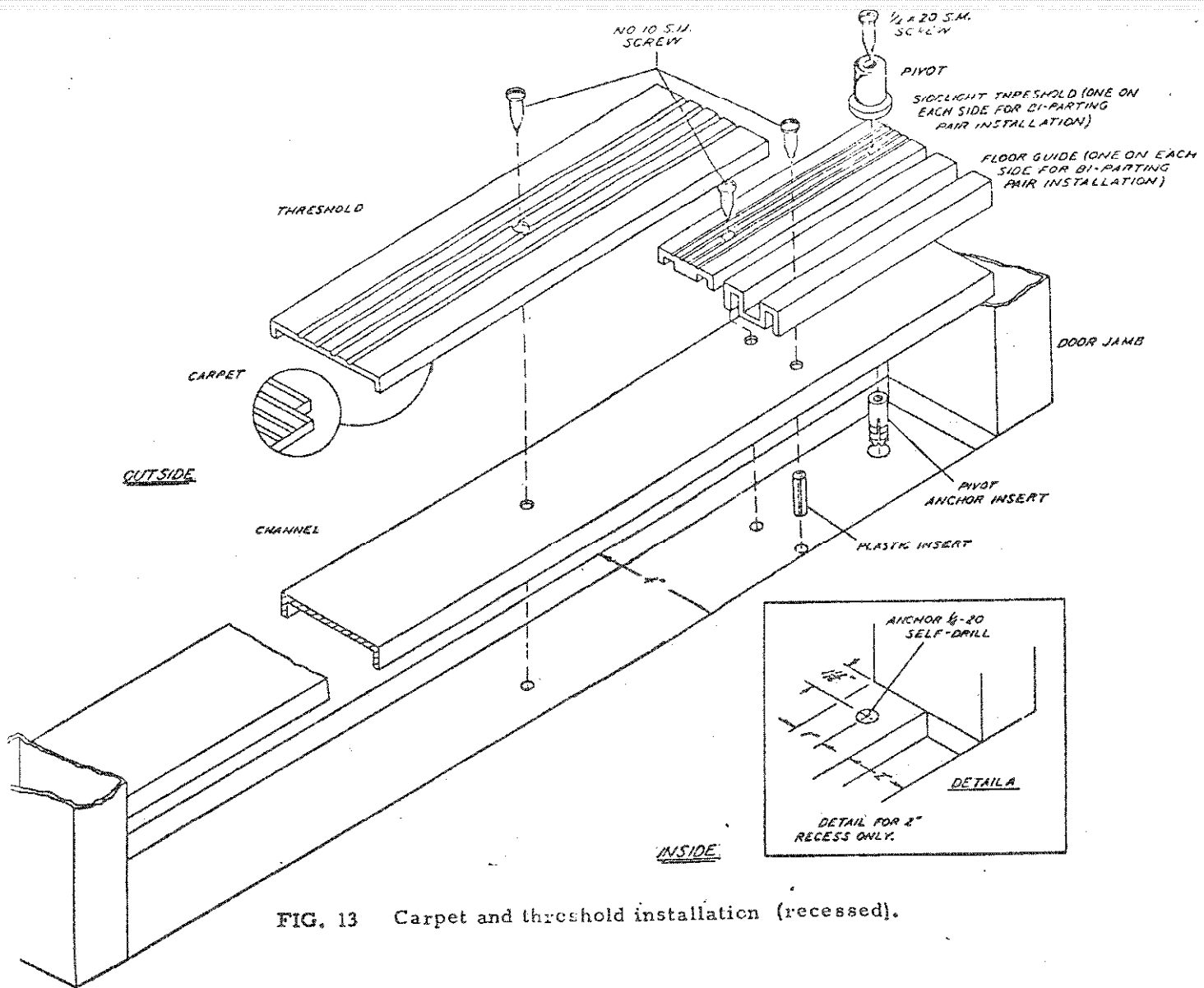

FIG. 13 Carpet and threshold installation (recessed).

5. Place the carpet frame into the recess provided. Level the frame, if necessary, with shims or stakes and clamps (not furnished). Cut the tops off the stakes (if used) about level with the stiffener on the carpet frame, (see FIG. 14). Secure the clamps to the angle bracket with \_\_\_\_\_ self threading screws.
6. Extend the wires across the space where the center threshold is to be installed. Place the channel over the wires and position it against the angle bracket on the carpet frame. Secure the channel to the angle bracket with \_\_\_\_\_ self threading screws.
7. Pour concrete into the groove on the inside of the frame up to the level of surface "A". (See FIG. 14). Pour concrete into the groove on the inside of the frame up to the level of surface "C" -- or surface "B" if the floor around the frame is to be tiled. All surfaces must be troweled smooth with no bumps or dips. After the concrete sets, remove the plastic insert from the frame.
8. Insert the carpets into the frame by first laying a wooden rod or broom handle across the center of the frame (see FIG. 15). Lay the carpet across the wooden rod and slide the edges of the carpet toward the frame. Slide out the wooden rod and force the edges of the carpet into the frame.
9. Splice the wires from the floor guide with the carpet lead wires. Secure with wire nuts.
10. It may be necessary to notch two corners of the carpet to fit around the corners of the thresholds and floor guides, depending upon the type of threshold installation (refer to FIG. 10). The beveled edges of the carpet that are against the threshold must fit snugly with the grooves in the threshold.
11. Secure the threshold with No. 10 sheet metal screws.

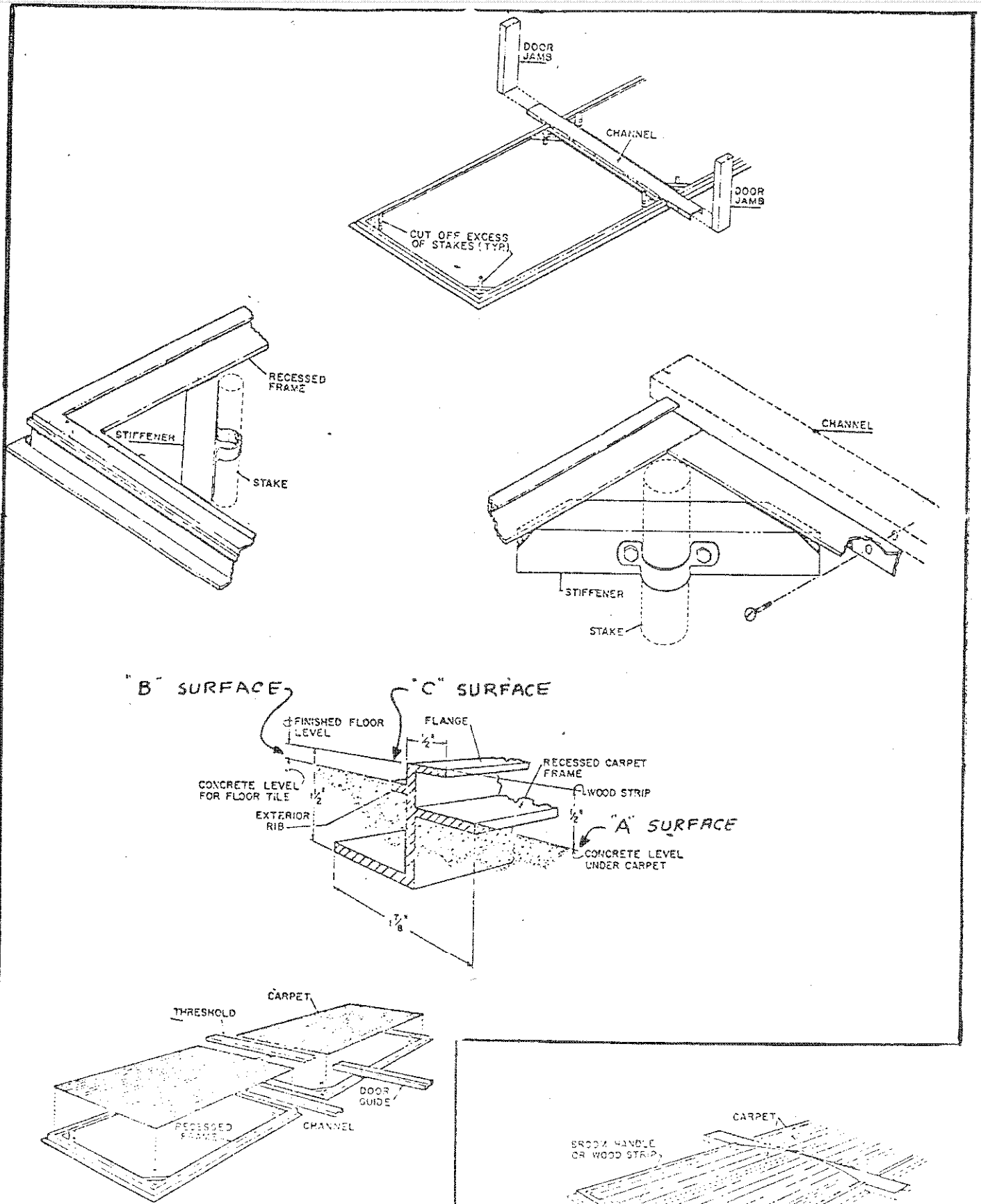

FIG. 14 Recessed carpet frame installation details.

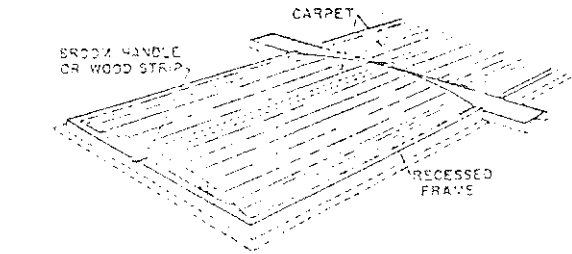

FIG. 15 Carpet installation (recessed).

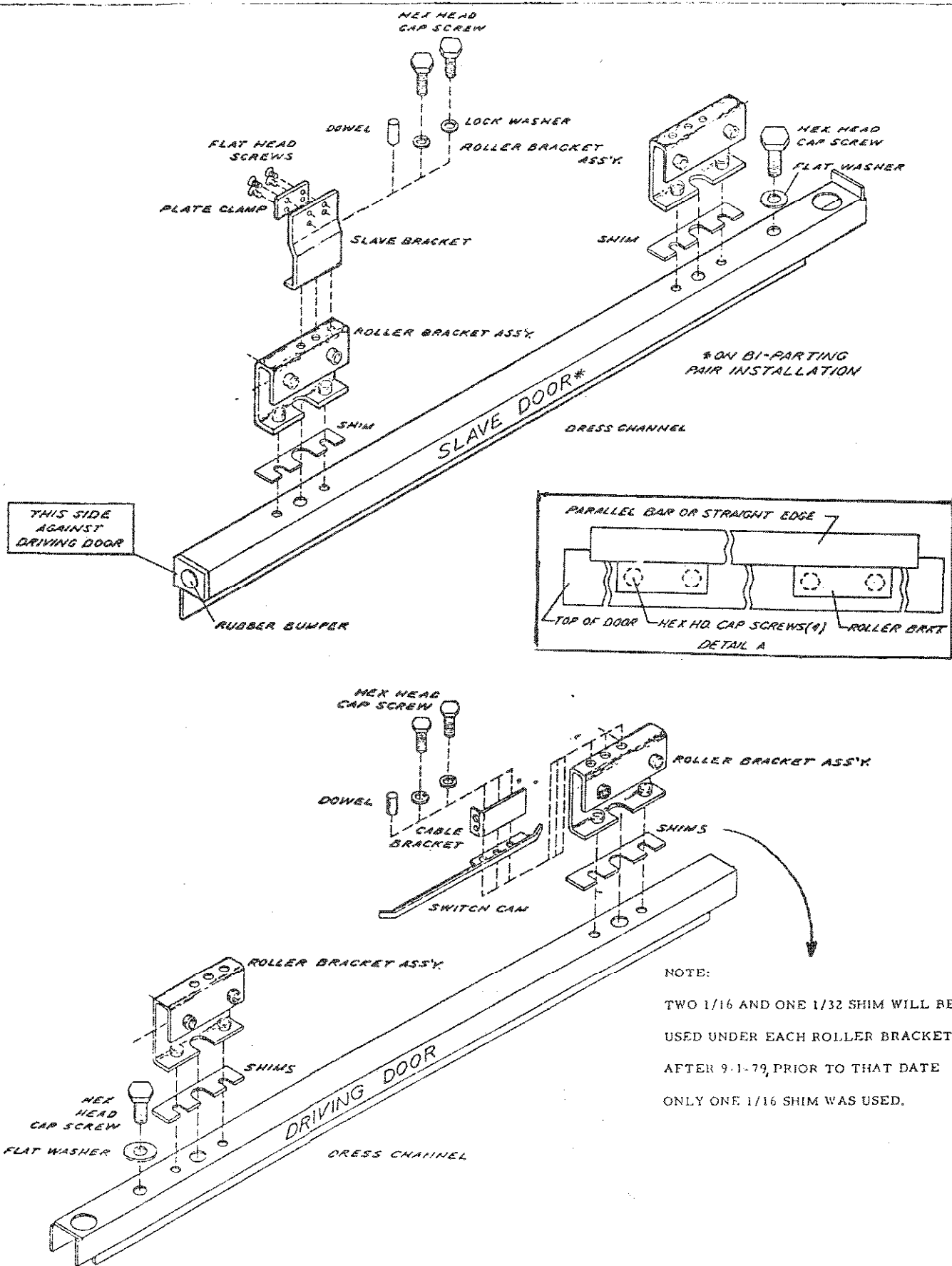

FIG. 16 Sliding door installation details.

## INSTALLATION OF SLIDING DOORS

1. Install the roller brackets, cable bracket and switch cam onto the top of the driving door as shown in FIG. 16. If applicable to this installation install the sliding switch cam also. Use two hex head cap screws, two lockwashers and a dowel pin in each bracket. If the installation is for bi-parting pairs install the roller brackets on the slave door. Be sure the brackets are properly positioned on each door as shown in FIG. 16. Install the slave bracket onto the roller bracket closest to the center of the door frame.

**NOTE:** Details shown in FIG. 16 are as viewed from the exterior of the building.

2. Check to see that both roller brackets are laterally aligned with each other as shown in Detail A of FIG. 16. This may be done with a long parallel bar or rigid metal straight edge. If better alignment is necessary, loosen the screws, hold the straight edge behind both brackets and slide each bracket against the straight edge. Tighten the screws.
3. Hang the door with the roller brackets hooked behind the rail in the header (see FIG. 17).

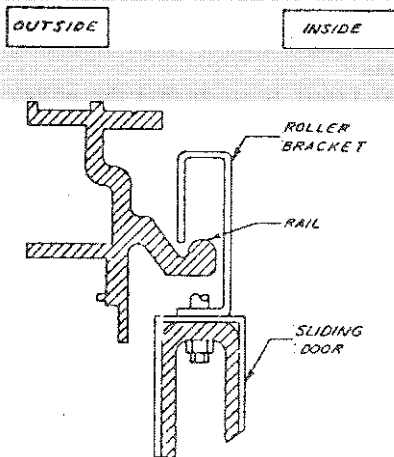

FIG. 17 Hanging door on rail.

Raise the door until the rollers can be placed on the rail and rolled into the bracket. Secure each roller with the oiler assembly into the bracket with a mounting stud and lockwasher as shown in FIG. 18.

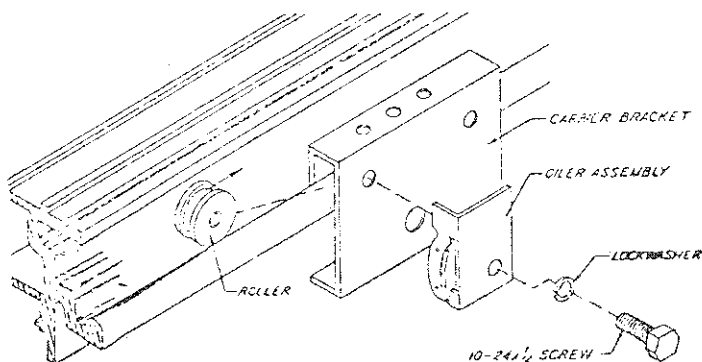

FIG. 18 Roller installation details.

**NOTE:** Shims may be added later under the roller brackets, if necessary, for proper positioning.

4. Insert the guide block of the bottom door guide assembly into the floor guide as shown in FIG. 19. Slide the bottom door guide into the door

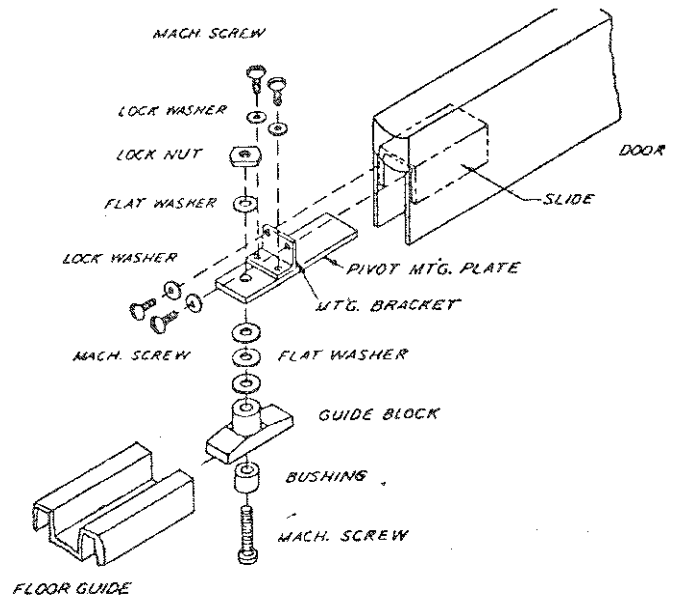

FIG. 19 Bottom door guide installation details.

and secure it to the slide with 10-24 x  $\frac{1}{2}$ " screws. Slide the door along the full length of its permissible travel distance. It should slide easily with no binding. The door guide block should not scrape against the floor guide and there should be a minimum clearance of  $\frac{1}{16}$ " between the underside of the guide block and the floor guide.

5. Check the clearance between the anti-riser (in the roller bracket) and the bottom of the rail (see FIG. 20). The clearance must be

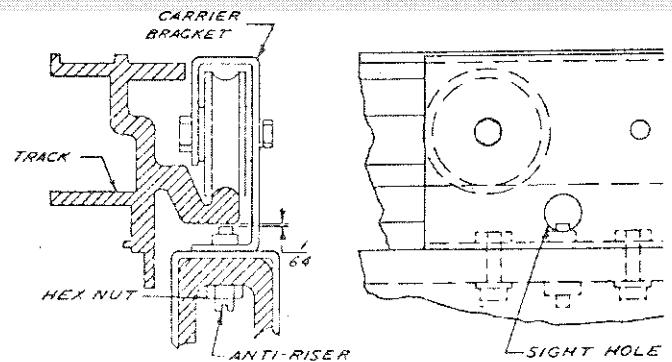

FIG. 20 Anti-Riser adjustment.

no greater than  $\frac{1}{64}$ " and must not touch the bottom of the rail. Use feeler gauges to check the clearance. If necessary to adjust the anti-riser, first loosen the hex nut. Turn the anti-riser in the required direction and tighten the hex nut.

## DOOR ACTIVATING DEVICES

### MOTION DETECTORS

There are a number of motion detecting devices available that may be used with the Astro-Slide II, Automatic Sliding Door Systems. These devices are for initiating the supply of electrical power required by the door opening equipment, through detection of moving persons or objects. Installation of a motion detector can eliminate the need for carpets, depending on certain conditions and type of door installation.

The available motion detectors are mainly of the micro-wave transceiver type and may be adjusted to detect motion within several different area patterns.

It is highly recommended that a photo-electric cell be installed in the system in conjunction with the motion detector as a safety feature. The photo-electric cell is usually installed less than three feet from the floor to prevent inadvertent closing of the door when a child or person of small height is passing through.

### NOTE:

If any type of activating device is used other than mats, or motion detectors, they must be installed within line of sight of the door so that person activating switch can observe the operation of the door.

### WALL PUSH PLATE, Model 1290A

Wall push plates are manually operated switching devices available from Dor-O-Matic. These may be used with the Astro-Slide II, Sliding Door Systems as secondary actuating devices in conjunction with floor switches (described in the following paragraph). The push plate by itself does not provide any safety feature. This must be provided by the other switching device with which it is used. The push plate is adjustable for many different applications in restaurants, hospitals and other institutions.

### FLOOR SWITCH, Model 1275A

The floor switch is recommended for installations where the use of standard carpet switches are prohibited, such as hospitals, restaurants and other institutions. The floor switch may be used in conjunction with the wall push plates (described in the previous paragraph).

### INSTALLATION OF SIDELITE PANELS

1. As shown in FIG. 21, Detail A, turn the pivot retracting screw in the header counter-clockwise as far as it goes. This will raise the retracting pivot.

2. If the sidelite panel is equipped with a limit arm, remove it by first unscrewing the shoulder screw, then the arm and pivot (see Detail B). If the panel is equipped with a closer arm (see Detail D) do not remove it. Remove the roller from the arm instead by first loosening the setscrew.
3. Position the sidelite panel with the latching mechanism (on the bottom of the door) onto the pivot (see Detail C). Press the panel onto latching mechanism until it snaps into place. Hold the door with the panel bearing directly under the retracted pivot. Turn the retracting screw clockwise until the pivot is inserted completely into the panel bearing.
4. Swing the panel, first to the closed position then to the breakaway position. It should swing freely with no binding.
5. Install the (a) panel limit arm or (b) closer arm as follows:
  - (A) Panel Limit Arm- Insert the roller on the panel limit arm into the notch in the header and slide it inward. Attach the free end of the arm to the top of the sidelite panel with the shoulder screw and spacer.
  - (B) Closer Arm- Insert the closer arm roller into the notch in the header and slide it inward. Attach the free end of the closer arm to the roller and tighten the setscrew.
6. Recheck the swinging action of the door, making sure the roller travels freely.

### INSTALLATION OF GLASS STOPS and DOOR SAG ADJUSTMENT

The installation of the glass stops in the sliding doors and sidelite panels is done in the same manner as described for the transom glass stops (page 7) except that the doors and panels are shipped with the glass stop frames already installed. The glass stops must be installed before the final operational checks are started.

Immediately after the glass has been installed the doors must be readjusted to prevent sagging when in the broken away position. The adjustment must be done with the door broken away. Unscrew the

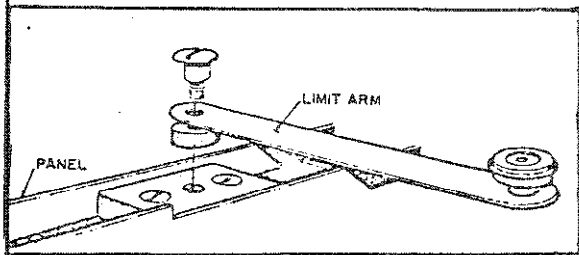

DETAIL "B"

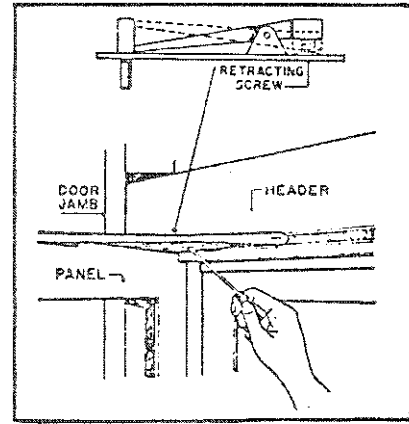

DETAIL "A"

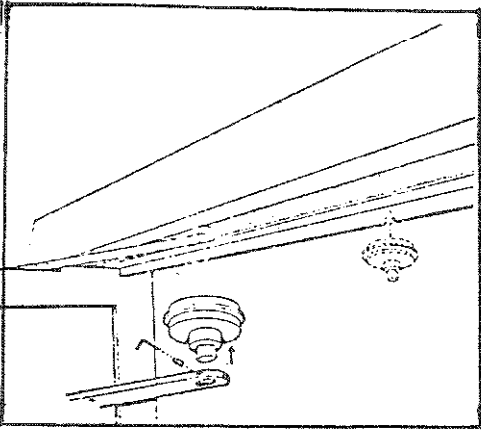
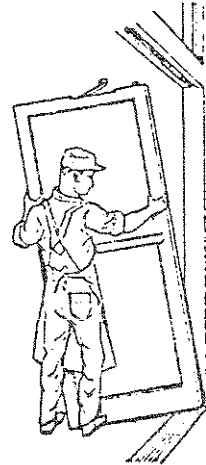

DETAIL "D"

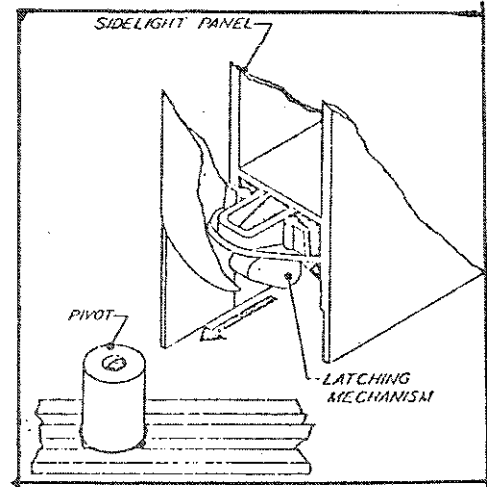

DETAIL "C"

FIG. 21 Sidelite panel installation details.

locking setscrew (see FIG. 22) about  $\frac{1}{4}$ -inch. Turn the hex head cap screw clockwise until the door is raised sufficiently to clear the threshold. Tighten the setscrew. Swing the doors to the closed and broken away positions several times to make sure there is sufficient clearance at the bottom.

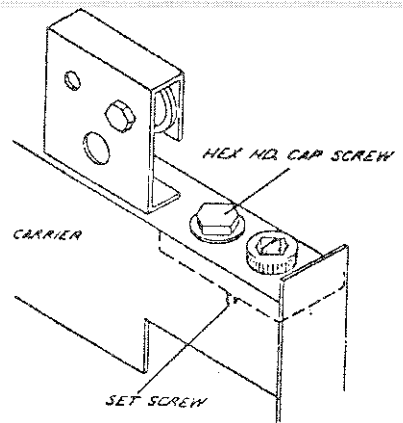

FIG. 22 Door sag adjustment.

## INSTALLATION OF CONTROL BOX

1. Slide two square nuts into the groove at the top of the header (see FIG. 23). Space the nuts

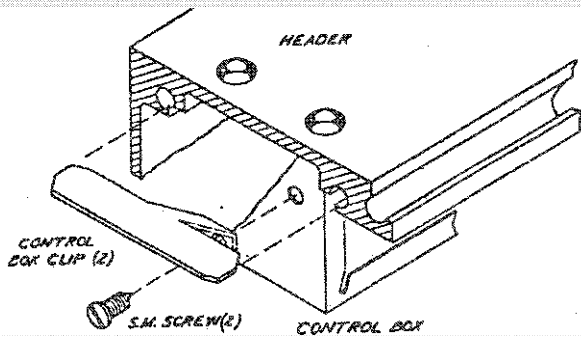
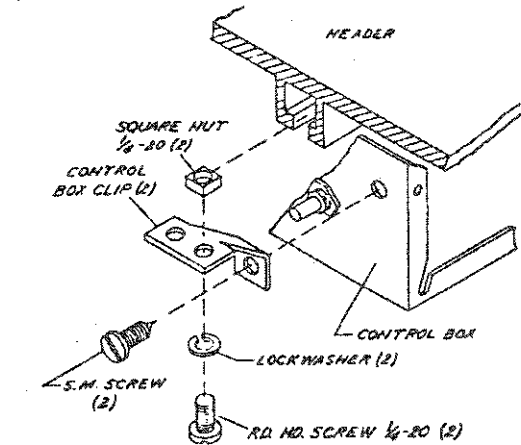

FIG. 23 Installation of control box.

about four inches further apart than the length of the header. Attach a control box clip to each nut with a lockwasher and a  $\frac{1}{4}$ -20 round head screw. Do not tighten the screws at this time.

2. Position the control box between the clips and slide the clips against the control box. Secure the control box to the clips with one sheet

metal screw on each side. Slide the control box to the left of where the motor is to be installed (described in the following paragraph). Tighten the  $\frac{1}{4}$ -20 round head screws.

**NOTE:** If the header design is of a previous model, the wider control box clips are used instead (see Detail A of FIG. 23). The clips are simply inserted into the grooves in the header and the control box secured with G-32 screws.

## INSTALLATION OF MOTOR and GEAR TRAIN ASSEMBLY

1. The two studs for mounting the motor and gear train assembly are located to the right of the control box (previously installed). Slip a rubber grommet onto each stud. The tapers on the grommets must point toward the open side of the header (see FIG. 24).
2. Install the motor and gear train assembly on the studs and secure it with a grommet, washer and hex nut on each stud. The tapered side of the grommets must point toward the closed side of the header. Tighten the nuts about 5 or 6 turns. Do not crush the grommets.

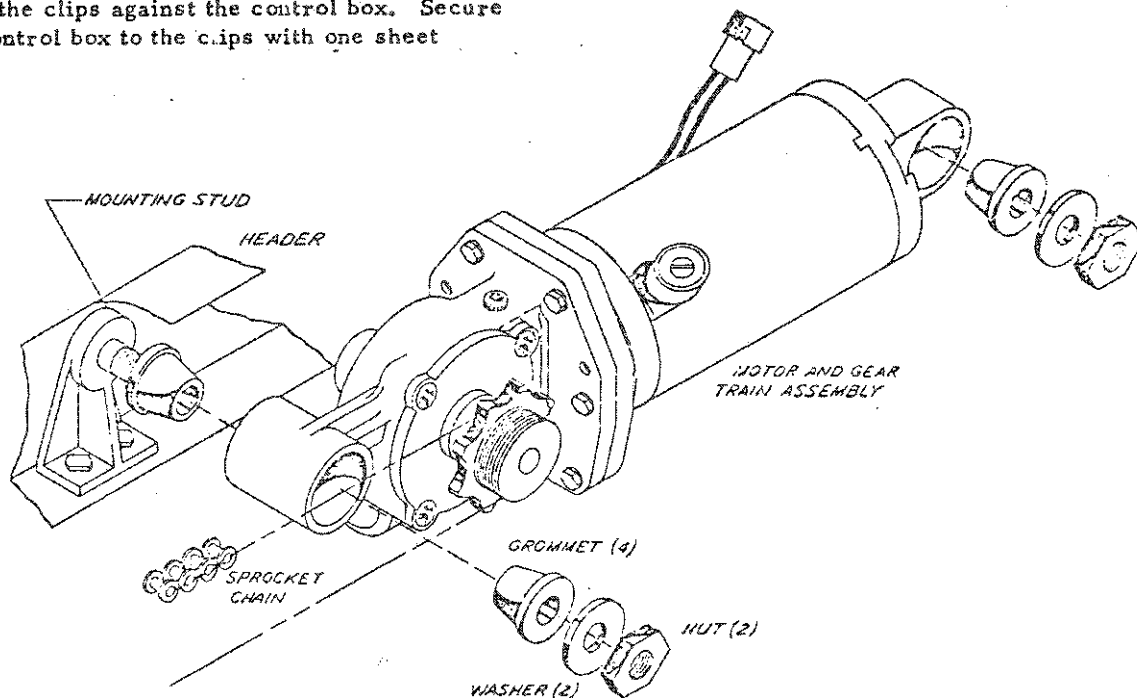

FIG. 24 Installation of motor and gear train assembly.



## INSTALLATION OF TIMING DEVICE

1. Install the Timing Device Assembly in the header, as shown in FIG. 25. Use two

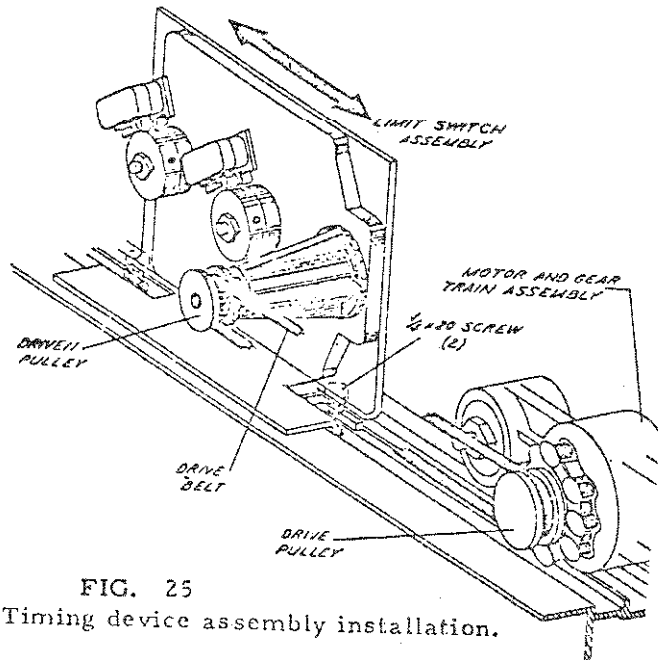

FIG. 25  
Timing device assembly installation.

$\frac{1}{4}$ -20 x  $\frac{1}{2}$ -inch cap screws. Do not tighten the screws at this point.

2. Slip the drive belt over the drive pulley on the motor and gear train assembly and the driven pulley on the timing device.
3. Slide the timing device assembly in the direction necessary to put enough tension on the belt to prevent slippage. Do not over tighten as this will cause unnecessary wear on the belt. Tighten the cap screws.

## INSTALLATION OF DRIVE CABLE ASSEMBLY

1. At a point about three feet from the end of the cable near the pulley bracket, loop the cable around the pulley (see FIG. 26). Install the pulley in the bracket with the mounting stud and lockwasher.
2. Engage the sprocket chain (part of the cable assembly) onto the sprocket. Insert the threaded stud through the top hole in the drive bracket. Position one locknut at the end of the threaded stud for tension adjustment.
3. Slip the threaded stud, on the free end of the cable, through the bottom hole in the drive bracket. Slip the adjusting nut assembly onto the end of the cable and up against the shoulder of the threaded stud. Pull the cable tight, hold it while sliding the adjusting nut assembly against the drive bracket and tighten the set-screws against the cable. Turn the adjusting nut clockwise to take up the slack on the cable.

**CAUTION:** Do not put excessive tension on the cable as this will cause unnecessary wear on the sprocket.

4. If the installation is for a Bi-Parting Pair System, secure the cable to the slave bracket on the slave door with four flat head screws, as shown in FIG. 26.
5. Manually slide the doors to the open and closed positions. There should be no interference with any of the moving parts on the cable assembly.
6. It is recommended that the sprocket wheel be slightly lubricated with WD40 or equivalent.

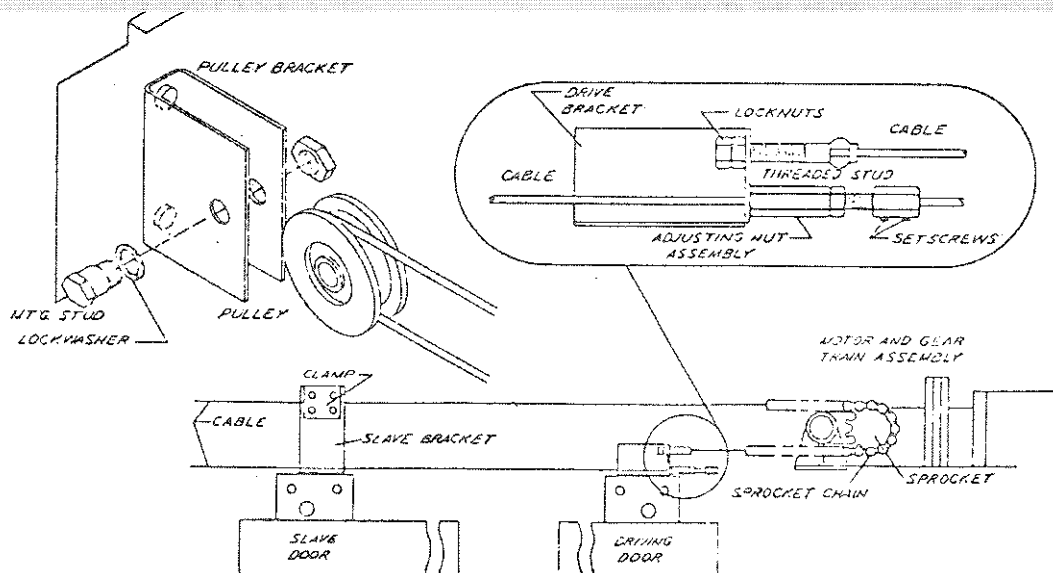

FIG. 26 Drive cable assembly installation details.

## ELECTRICAL CONNECTIONS

1. Insert a 3-wire metal clad cable through the top hole at the end of the header (see FIG. 27)

2. Connect the male and female plugs of the wiring harnesses as shown in FIG. 27.

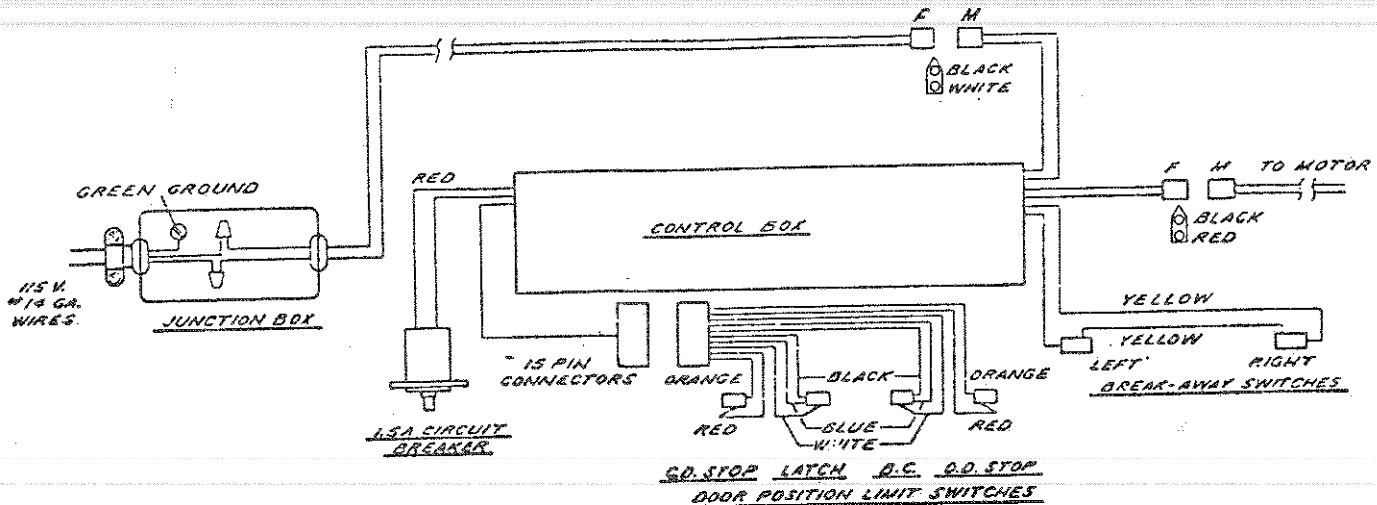

FIG. 27 Electrical connections.

and secure the cable to the junction box. Connect the green wire to the grounding terminal. Insert the bare ends of the control box power cable into the terminal box and splice the ends to the metal clad wires with wire nuts.

**CAUTION:** Make sure that the blk/wht connector is plugged into the connector from the terminal box and the blk/red is connected to the motor. Wrong connections may cause damage to the components in the control box.

## ADJUSTMENTS and OPERATIONAL CHECKS

### ADJUSTMENTS and OPERATIONAL CHECKS

#### A. Door Positioning

1. Manually slide the doors to the closed position. A single door must be flush up against the jamb. Bi-Parting Pair Doors must be flush against each other and centered between the door jambs. If necessary to center the doors, first loosen the screws on the slave bracket. Center the closing side of the driving door between the jambs. Slide the slave door against the driving door and tighten the screws on the slave bracket.

#### B. Cam and Switch Positioning

##### 1. Models with Rotating Cams

The rotating cams, located in the timing device assembly (see FIG. 28) actuate the micro-switches that induce current to the opening and closing circuitry. The "LATCH" and "BACK CHECK" cams are factory set for optimum conditions with the weights and widths of the doors taken into consideration. A considerable variation from the optimum may necessitate re-adjustment of these cams. The "OPEN" and "CLOSE" cams, however, must be set during the installation of the door system.

**NOTE:** The timing device, shown in FIG. 28, is for a left handed door installation. For a right handed door installation the cams are assembled on the opposite shafts. Also, the directions of the right hand door positions are

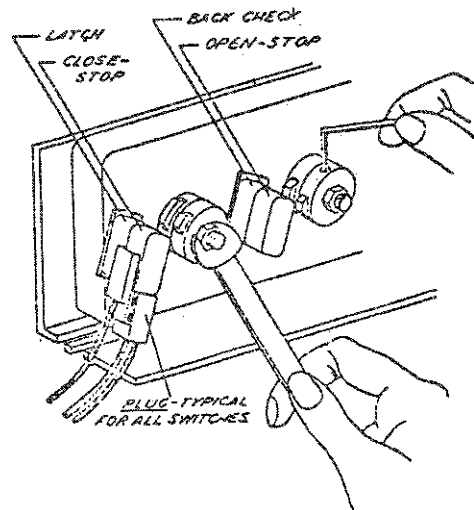

FIG. 28 Cam positioning (rotating).

opposite to those shown in FIGURES 29 through 32

If the factory settings are satisfactory for the required installation, perform the following steps (a) and (b) and disregard (c) through (f). If all cams must be adjusted disregard steps (a) and (b) and proceed with steps (c) through (f).

(a) Slide the driving door to the "OPEN" position until the side is 3 inches from the

rubber stop (see FIG. 29). Loosen the hex

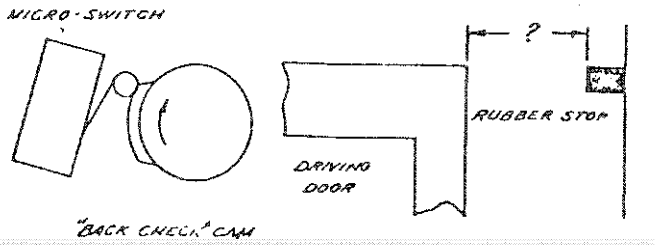

FIG. 29 "Back Check" stop cam adjustments. Loosen the hex nut on the "BACK CHECK" and "OPEN" camshaft. Manually rotate the cam until the switch arm contacts the "OPEN" cam lobe at the beginning of the high rise. Tighten the hex nut. Scribe a pencil mark on the header flush with the side of the door. This is to be used as a reference point during the operational checks.

(b) Slide the driving door toward the closed position until the edge is between 1 and 2 inches from the center of the header (or from the door jamb if installation is for a single door). See FIG. 31. Loosen the hex nut on the end of the "LATCH" and "CLOSE" camshaft. Rotate both cams until the switch arm contacts the "CLOSE" cam lobe at the beginning of the high rise. Tighten the hex nut. Scribe a pencil mark on the header, flush with the side of the door.

(c) Slide the driving door to the open position until the side is about 2 inches from the rubber stop (see FIG. 29). Loosen the hex nut at the end of the "OPEN" and "BACK CHECK" camshaft. Manually rotate the "BACK CHECK" cam until the switch arm contacts the cam lobe at the beginning of the high rise. Tighten the hex nut. Scribe a pencil mark on the header, flush with the edge of the door.

(d) Slide the driving door to a distance of about 3 inches from the rubber stop (see FIG. 30)

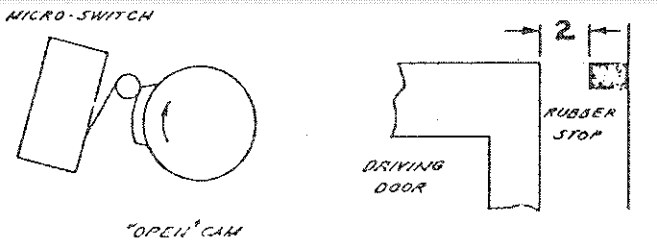

FIG. 30 "Open Door" stop cam adjustments.

Loosen the setscrew in the "OPEN" cam. Manually rotate the "OPEN" cam until the switch arm contacts the cam lobe at the beginning of the high rise. Tighten the setscrew. Scribe a pencil mark on the header flush with the side of the door.

(e) Slide the driving door toward the closed position until the edge is about 6 inches from the center of the header (see FIG. 31) or

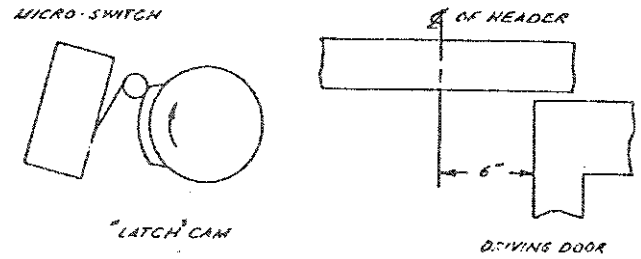

FIG. 31 "Latch" stop cam adjustments.

from the door jamb if the installation is for a single door. Loosen the hex nut at the end of the "LATCH" and "CLOSE" camshaft. Manually rotate the "LATCH" cam until the switch arm contacts the cam lobe at the beginning of the high rise. Tighten the hex nut. Scribe a pencil mark on the header, flush with the side of the door.

(f) Slide the driving door toward the closed position until the edge is about 1 to 2 inches from the center of the header (see FIG. 32) or from the door jamb if the

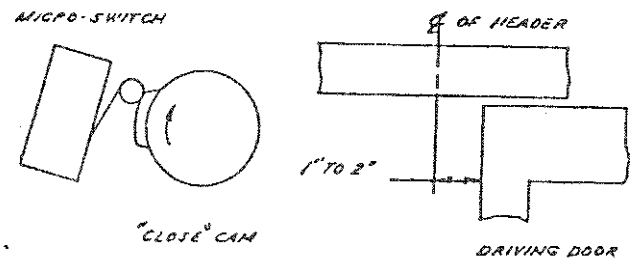

FIG. 32 "Close Door" stop cam adjustments.

installation is for a single door. Loosen the setscrew in the "CLOSE" cam. Manually rotate the "CLOSE" cam until the switch arm contacts the cam lobe at the beginning of the high rise. Tighten the setscrew. Scribe a pencil mark on the header, flush with the side of the door.

## 2. Models with Sliding Cams

The sliding cam, attached to the driving door roller bracket (see FIG. 33),

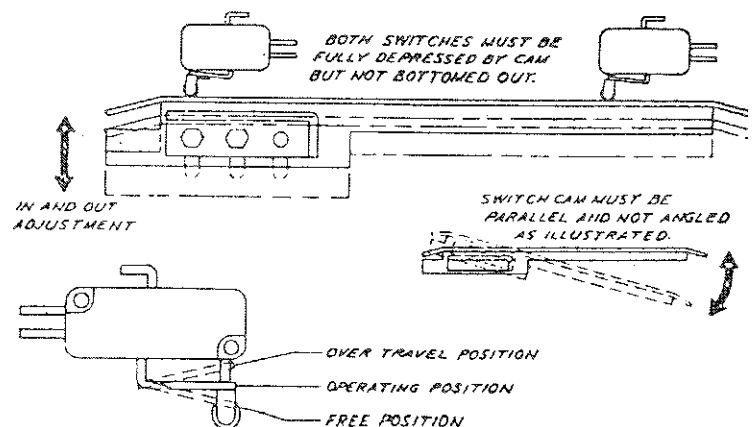

FIG. 33 Switch arm positions.

actuates the micro-switches that induce current to the opening and closing circuitry. Proper positioning of this cam is accomplished by first loosening the two hex head screws and moving the cam toward the front or back side of the header, as required. The cam, after being secured to the bracket must be parallel to the header, to the extent that it places two switch arms in the operating position, simultaneously.

**CAUTION:** The sliding cam must never be positioned to "bottom" any of the switch arms.

The micro-switches are secured to the header with clips. Positioning of these switches is accomplished by first removing the clips and positioning the switches as required. Locations of the switches, relative to each other are shown in FIG. 34.

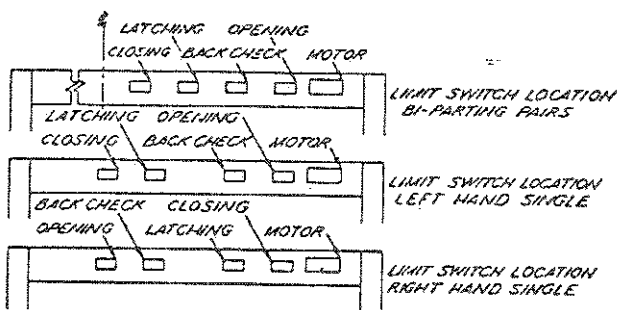

FIG. 34 Micro-switch locations.

**C. Door Speed and Delay Controls**

1. The opening, closing and time delay intervals between opening and closing of the doors are determined by the manual settings of the potentiometers in the control box. These potentiometers are readily accessible when the header cover is opened or removed. Their relative positions are shown in FIG. 35.



FIG. 35 Door speed and time delay controls.

2. A clockwise turn on any of the potentiometers will increase the timing of their functions -- a counterclockwise turn will decrease them.

**D. Operational Checks.**

1. Supply 115 VAC electrical power to the system.
2. Operate the doors to the open position. Each door should open smoothly and

silently to a fully open position during a period of 1.5 to 2 seconds. Adjust the OPEN potentiometer, as required, if the door speed is not within these limits.

3. Operate the door to the closed position. The closing speed of the door should not exceed 1.8 feet per second. Adjust the CLOSE potentiometer if necessary.

4. Again, operate the door to the open position. There should be a time delay of 1.5 seconds before the door begins to close. Adjust the TIME DELAY POTENTIOMETER, if necessary.

5. While the door is opening, check the speed of the door at a point of about 9 inches from where it stops. This speed should be not more than .5 feet per second. This speed may be adjusted by turning the BACK CHECK potentiometer as required.

6. While the door is closing, check the speed of the door at a point about 9 inches before it closes. The speed should not exceed .5 feet per second. Adjust the speed of the LATCH potentiometer if the speed is not correct.



**SLIDING DOOR CLOSING SPEED TABLE**

Door speed must not exceed stated values

SIZE	125# DOOR	150# DOOR	200# DOOR
24"	1.76 Sec.	1.93 sec.	2.23 sec.
30"	2.20 sec.	2.42 sec.	2.79 sec.
36"	2.65 sec.	2.90 sec.	3.35 sec.
42"	3.09 sec.	3.38 sec.	3.91 sec.
48"	3.53 sec.	3.86 sec.	4.46 sec.

NOTE: For sizes or weights not listed use next larger size or weight.

**PUTTING THE SYSTEM INTO SERVICE**

1. Remove all tools, installation equipment and debris from the vicinity of the doors.
2. Install all safety, traffic control and instruction decals, where required. Also install other decals where required. THIS IS IMPORTANT. Failure to install, or removal of these decals voids all responsibility of the DOR-O-MATIC CO.
3. Install and close the header cover.
4. Verbally explain the proper operation of the door system to the owner or Person in charge.

## TROUBLE SHOOTING

### General

The following Trouble Shooting Chart lists the most common malfunctions likely to occur in the motor-driven Astro-Slide II Automatic Sliding Door System, their probable causes and correct-

ive measures. The schematic diagram in FIG. 36 should also be used with this chart. Also, check to make sure that all electrical wiring connections are correct and all wires secured where necessary, with cable clips.

## TROUBLE SHOOTING CHART

<u>MALFUNCTION</u>	<u>PROBABLE CAUSE</u>	<u>CORRECTION</u>	<u>MALFUNCTION</u>	<u>PROBABLE CAUSE</u>	<u>CORRECTION</u>
Door does not open.	1. Defective contacts in carpet switch, motion detector or other type of initiating switch.	1. Replace carpet or other initiating switch.		9. OPEN Potentiometer (1.8K) defective or not adjusted properly. See label on control box.	9. Adjust Potentiometer.
	2. Opening micro-switch defective or improperly positioned.	2. Reposition or replace micro-switch.		10. Power turned off.	10. Turn on power.
	3. Sliding cam or rotating cam improperly positioned.	3. Reposition sliding or rotating cam.		11. Door locked.	11. Unlock door.
	4. Burned-out Fuse.	4. Replace Fuse.	Sliding door does not close.	1. Closing micro-switch defective or improperly positioned (Sliding Cam).	1. Replace or reposition switch.
	5. Defective Motor	5. Repair or replace motor.		2. Sliding cam improperly positioned.	2. Reposition cam.
	6. Sprocket chain disengaged from sprocket.	6. Re-engage chain. Check condition of sprocket. If necessary, replace.		3. Anti-Riser jammed against rail.	3. Readjust Anti-Riser.
	7. Obstruction in floor guide.	7. Remove obstruction and clean floor guide thoroughly.		4. Sprocket chain disengaged from sprocket.	4. Re-engage sprocket chain. Check condition of sprocket. Replace if necessary.
	8. Anti-Riser jammed against bottom of rail.	8. Re-adjust anti-riser.		5. Door binding in floor guide.	5. Remove obstruction and clean floor guide thoroughly.
			6. Short circuit in activating device.	6. Replace activating device.	

## TROUBLE SHOOTING CHART

<u>MALFUNCTION</u>	<u>PROBABLE CAUSE</u>	<u>CORRECTION</u>	<u>MALFUNCTION</u>	<u>PROBABLE CAUSE</u>	<u>CORRECTION</u>
Sliding door does not close.	7. Rotating cam (Close) improperly positioned.	7. Reposition cam.	Door closes too fast.	1. Potentiometer (CLOSE) improperly adjusted.	1. Adjust Potentiometer. See label on control box.
Sidelite Panel does not break away after power failure.	1. Defective hydraulic assembly on door closer.	1. Replace hydraulic assembly.	Door closes too slowly.	1. Potentiometer (CLOSE) improperly adjusted.	1. Adjust Potentiometer. See label on control box.
	2. Breakaway reed switch (N. C.) defective.	2. Replace switch.		2. Anti-Riser scraping against rail.	2. Re-adjust Anti-Riser.
	3. Obstruction in limit arm roller track.	3. Remove obstruction and clean roller track thoroughly. Check condition of roller. Replace if necessary.	Door closes immediately after opening.	1. Potentiometer (Time Delay) improperly adjusted.	1. Adjust Potentiometer. See label on control box.
Sliding door does not close completely.	1. Cable fasteners not properly positioned.	1. Reposition fasteners.	Door opens with impact.	"BACK CHECK" Potentiometer improperly adjusted.	Adjust "BACK CHECK" potentiometer.
	2. Closing micro-switch improperly positioned.	2. Reposition micro-switch.	Door closes with impact.	"LATCH" potentiometer improperly adjusted.	Adjust "LATCH" potentiometer.
	3. Anti-Riser binding against rail.	3. Readjust Anti-Riser.	Motor buzzes but does not run.	Power supply and motor connectors improperly connected.	Make proper connections. See wiring diagram.