

PRODUCT DESCRIPTION

The LO-21U (PN: 10LO21U) is a micro-processed lock out module designed to operate on swing door applications with BEA's Bodyguard or DK-12 overhead presence sensor. The LO-21U interprets door open or door closed position based upon motor voltage input. The motor voltage information is sent from the LO-21U to the Bodyguard or DK-12 via data lines. The LO-21U provides optional safety beam input (dry contacts) to override the inhibit signal during closing.

- ❑ **ANSI / BHMA 156.10-2005 requires the use of a sensor or photobeam on the swing side of the door when using a header mounted safety sensor, such as the Bodyguard or DK12. For more information reference the ANSI 156.10 standard.**

TECHNICAL SPECIFICATIONS

DESCRIPTION	SPECIFICATION
Supply voltage	12 to 24 VAC / 15 to 24 VDC
Operating frequency	4 MHz (Microprocessor)
Power consumption	10 mA at rest, 50 mA Maximum
Output	(2) SPST Relays
Maximum voltage – Relay contacts	60 VDC, 120 VAC
Maximum current – Relay contacts	2A DC, 0.5 A AC

COMPONENT ID

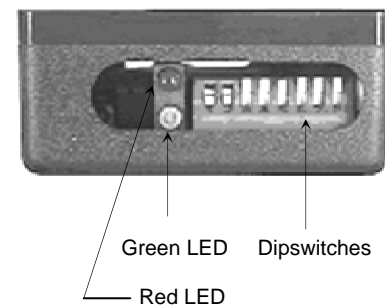

SAFETY PRECAUTIONS



CAUTION

- Shut off all power going to the header before attempting any wiring procedures.
- Maintain a clean & safe environment when working in public areas.
- Constantly be aware of pedestrian traffic around the door area.
- Always stop pedestrian traffic through the doorway when performing tests that may result in unexpected reactions by the door.
- Always check placement of all wiring before powering up to insure that moving door parts will not catch any wires and cause damage to equipment.
- Ensure compliance with all applicable safety standards (i.e. ANSI A156.10) upon completion of installation.

WIRING INSTRUCTIONS

1. Wire the LO-21U according to the chart below.

WIRE COLOR	CONNECTION POINT
Black	Motor (-)
Red	Motor (+)
Violet	Bodyguard Pin 3 (Common)
White	Bodyguard Pin 6 (Data -)
Black / White	Safety Beam (Common)
Orange	Power (-) / 12 to 24 volts AC/DC
Gray	Bodyguard Pin 4 (N/O)
Red / White	Bodyguard Pin 7 (Data +) and Safety Beam (N/O)
Brown	Power (+) / 12 to 24 volts AC/DC
Green	Door Control (Common)
Blue	Door Control (Activate)
Yellow	Door Control (Safety)

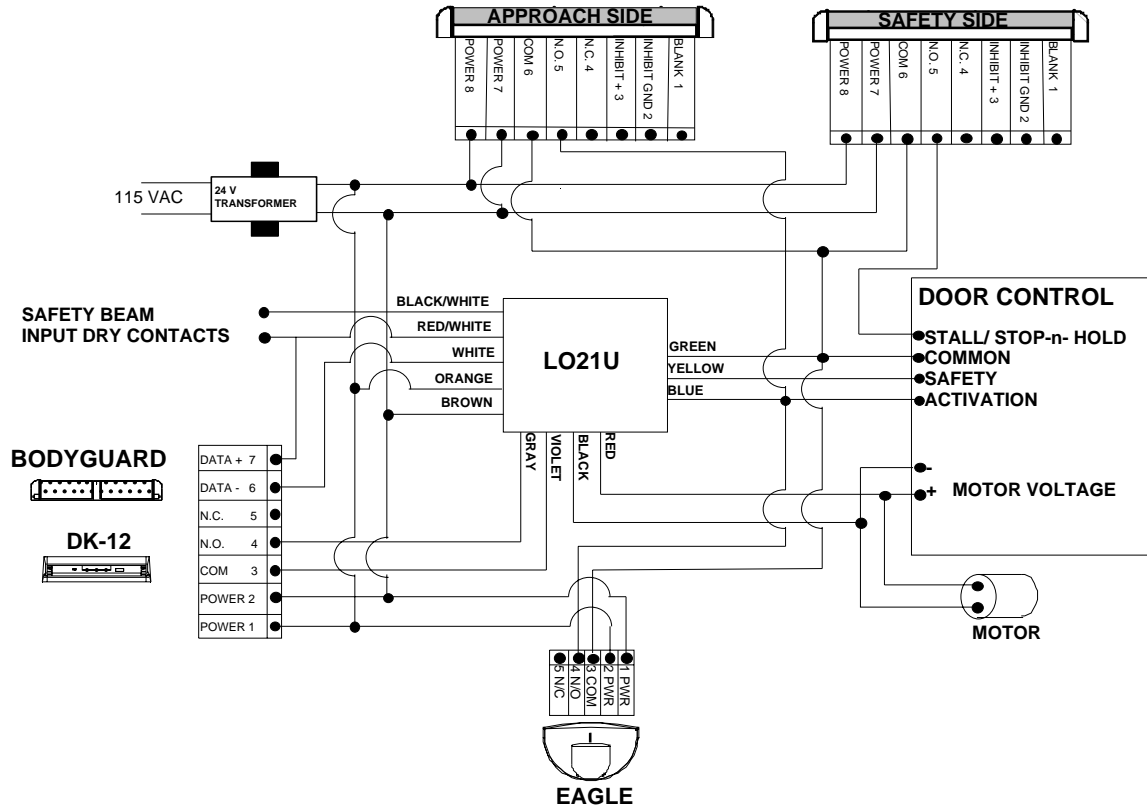

DIPSWITCH SETTINGS

1. The dipswitches are located at the end of the LO-21U, opposite of the wire connection terminal. There are 8 positions available. Dipswitch designations are as follows:

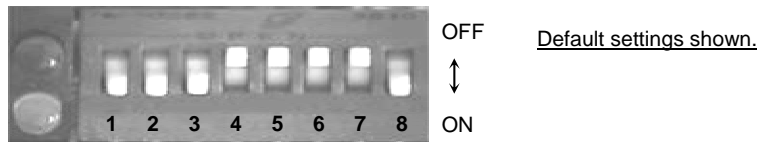

Dipswitch #	Function	OFF	ON
1	Time Delay: 1 sec. value	0 seconds	1 second
2	Time Delay: 2 sec. value	0 seconds	2 second
3	Time Delay: 4 sec. value	0 seconds	4 second
4	Time Delay: 8 sec. value	0 seconds	8 second
5	Time Delay: 16 sec. value	0 seconds	16 second
6	Voltage switching device	Voltage source is other than motor	Motor Voltage
7	Safety circuit logic (used with DS #8)	7 OFF / 8 ON = N/O Safety Circuit	
8	Safety circuit logic (used with DS #7)	7 ON / 8 OFF = N/C Safety Circuit	

**DIPSWITCH
SETTINGS – Cont.**

- Use the chart (at right) for a quick-reference for time delay settings (switches 1 through 5). Factory setting is 7 seconds.

Example:

The normal closing cycle of an automatic door lasts about 7 seconds. In order to get the proper closing lock out time delay needed for the closing cycle of the door, the dipswitches need to be set according to the chart on page 3 for 7 seconds. To get the proper lock out time delay dip switches 1, 2, & 3 must be in the ON position and Dip Switch 4 must be in the OFF position.

Seconds	dip 1 1 sec	dip 2 2 sec	dip 3 4 sec	dip 4 8 sec	dip 5 16 sec
1	ON	OFF	OFF	OFF	OFF
2	OFF	ON	OFF	OFF	OFF
3	ON	ON	OFF	OFF	OFF
4	OFF	OFF	ON	OFF	OFF
5	ON	OFF	ON	OFF	OFF
6	OFF	ON	ON	OFF	OFF
7	ON	ON	ON	OFF	OFF
8	OFF	OFF	OFF	ON	OFF
9	ON	OFF	OFF	ON	OFF
10	OFF	ON	OFF	ON	OFF
11	ON	ON	OFF	ON	OFF
12	OFF	OFF	ON	ON	OFF
13	ON	OFF	ON	ON	OFF
14	OFF	ON	ON	ON	OFF
15	ON	ON	ON	ON	OFF
16	OFF	OFF	OFF	OFF	ON
17	ON	OFF	OFF	OFF	ON
18	OFF	ON	OFF	OFF	ON
19	ON	ON	OFF	OFF	ON
20	OFF	OFF	ON	OFF	ON
21	ON	OFF	ON	OFF	ON
22	OFF	ON	ON	OFF	ON
23	ON	ON	ON	OFF	ON
24	OFF	OFF	OFF	ON	ON
25	ON	OFF	OFF	ON	ON
26	OFF	ON	OFF	ON	ON
27	ON	ON	OFF	ON	ON
28	OFF	OFF	ON	ON	ON
29	ON	OFF	ON	ON	ON
30	OFF	ON	ON	ON	ON
31	ON	ON	ON	ON	ON

- DIPSWITCH #6: Corresponds to the type of motor voltage logic on the RED and BLACK wires. Dipswitch 6 should be on for all applications that have the red and black wires going to a parallel motor connection. Dipswitch 6 should be OFF for applications where voltage is present on the red and black wires at the closed door position, and where 0 volts is present at the door open position.
- DIPSWITCH 7 OFF & 8 ON: Provides a CLOSED circuit between the GREEN (COMMON) and YELLOW (SAFETY) during BODYGUARD detection and an OPEN circuit at all other times.
- DIPSWITCH 7 ON & 8 OFF: Provides a OPEN circuit between the GREEN (COMMON) and YELLOW (SAFETY) during BODYGUARD detection and a CLOSED circuit at all other times. (Example: Besam PowerSwing).

Brand / Model Of Operator	Dipswitch 6, 7 & 8 Setting
Besam Swingmaster (ETIK)	6 ON, 7 OFF, 8 ON
Besam Swingmaster MP (CUP)	6 OFF 7 OFF, 8 ON
Besam Electra 150	6 ON, 7 OFF, 8 ON
Besam PowerSwing	6 ON, 7 ON, 8 OFF
Doromatic Astro-Swing Mid-Swing Senior Swing	6 ON, 7 OFF, 8 ON
Gyro-Tech (all except Gemini 710 AND U11)	6 ON, 7 OFF, 8 ON
Horton 4000	6 ON, 7 OFF, 8 ON
Horton 7000	6 ON, 7 OFF, 8 ON
KM 2000	6 ON, 7 OFF, 8 ON
Stanley Magic Swing Magic Force (with safety)	6 ON, 7 OFF, 8 ON

The following instructions pertain to the setup procedures and the related indications that should be observed.

RED LED
Bodyguard's output is
Applied to the safety circuit

GREEN LED
Bodyguard's output is
Applied to the activation circuit

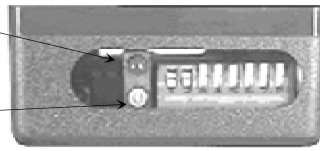

Set the dipswitches according to the chart below to achieve the desired lock out time delay.

Immediately following each step, is a corrective action to perform if the step does not pass:

1. Set the On-Off-Hold Open switch to the OFF position. If a switch is not available, unplug the activating device for the door.
2. To begin the set-up, apply power to the door system, to the LO-21U module, and to the Bodyguard. The Bodyguard shall immediately begin flashing green to indicate a setup for the closed door position.
 - ❑ If the Bodyguard does not begin flashing green, check to insure it is receiving the correct power at inputs 1 & 2 at the 7-position terminal at the left side of the Bodyguard. Correct as necessary.
3. Do not enter into the field of detection while the Bodyguard is setting up. After approximately 6 seconds, the green LED will expire.
4. Activate the door to the open position with the On-Off-Hold Open switch, or by jumpering the activate circuit. The Bodyguard shall begin flashing green again while it is learning the "door open" set-up. Again, approx. 6 seconds of un-interruption will allow a setup to complete. Once complete, the door should begin to close if activation is removed. Place the On-Off-Hold Open switch to the On position. Normal operation thereafter.
 - ❑ If the Bodyguard does not begin flashing green when the door reaches full open, improper voltage may exist on terminals 6 & 7 of the Bodyguard. Perform following:
 - Using a BEA remote control, and with the door in the open position, unlock the Bodyguard, then press the Magic Wand key and then the number 2. This will force a setup for the open door position. If the green LED does not begin flashing, unplug the 7-position connector at the Bodyguard.
 - Use a multi-meter (set to a DC voltage scale) to test the voltage at terminal 6 & 7. Place the positive probe on terminal 7 and the negative probe on terminal 6. There should be approximately 12 Volts DC. If voltage is 0 volts, check the white and red/white striped wires from the connector back to the LO-21U for any breaks.
 - If wiring is good, check the voltage at the red and black wires on the LO-21U. Using a multi-meter, place the positive probe on the red wire, and the negative probe on the black wire. Voltage should not be less than 6 volts DC. If it is less, try increasing the stall voltage at the door control. If voltage is 0 volts, make sure there is a good connection on the red and black wires. Also make sure the LO-21U has the proper input voltage at the orange and brown wires.
5. Once the Bodyguard is functioning correctly with regard to the open and closed door setup, walk testing may begin.
 - ❑ Do NOT proceed with walk-test until the Bodyguard is functioning correctly.
6. The LO-21U has two LED's to indicate what function it is performing. When the door is closed and someone steps into the detection zone of the Bodyguard, the illumination of the **red LED** on the LO-21U will indicate that the LO-21U is triggering the **safety circuit**. Therefore, the door will remain closed until the Bodyguard zone is clear. The red LED will expire on the LO-21U and on the Bodyguard will shut off when the detection zone is clear. With the door in the closed position, stand in the Bodyguard detection field and have someone activate the door (Eagle, push plate, etc.). The door should not open. Clear the detection field of the Bodyguard, while keeping the door activated. The door should open thereafter.
 - ❑ If the red led comes on at the Bodyguard, but not at the LO-21U, check to insure good wiring on the gray and violet wires between the Bodyguard and the LO-21U.
 - ❑ If the red LED comes on at the Bodyguard and the LO-21U, but the door has no safety, check the green and yellow wires between the LO-21U and the door control. If connections are good, jumper the common and safety terminals at the door control, then activate the door to insure that the safety function is ok.
7. Once the Bodyguard zone is clear and the door has been activated, it will open and remain open as long as there is activation, or until door control and sensor hold-times have expired. If someone steps into the Bodyguard zone when the door is open, the illumination of the **green LED** will indicate that the LO-21U is triggering the **activation circuitry** of the door, thus holding the door open for as long as someone is in the Bodyguard detection pattern.
 - ❑ If the red led comes on at the Bodyguard, but not at the LO-21U, check to insure good wiring on the gray and violet wires between the Bodyguard and the LO-21U.
 - ❑ If the red LED comes on at the Bodyguard and the green LED comes on at the LO-21U, but the door does not hold open when the Bodyguard is in detection, check the blue and green wires between the LO-21U and the door controls activation circuit.
 - ❑ Reverse the red and black wires at the LO-21U and try Step 7 again.
 - ❑ If all steps are Ok, LO-21U may be faulty. Replace as necessary.

SET-UP INSTRUCTIONS – Cont.

8. When all functions of the control and LO-21U have been confirmed, the lockout time delay will need to be set. Time delay is set by using dipswitches 1 through 5. Perform the following steps:
- Activate the door to the open position.
 - Allow the door to close and count how many seconds it takes for the overall door closing cycle
 - Configure the dip switches according to the chart on Page 3 for the lock out time that is required
 - Activate the door again to the open position
 - Stand outside of the Bodyguard detection pattern, and while the door is closing, observe the red LED on the Bodyguard
 - The red LED on the Bodyguard should NOT illuminate during the closing cycle. If it does, it is probably seeing the door at the very last degree or two of door closing, which would indicate that the lock out time needs to be slightly increased.
 - Reconfigure the dipswitches to add 1 second of lock out time.
 - When the lock out time is correct. The red LED will not illuminate during the entire closing cycle of the door.
 - The last test is to insure that the Bodyguard detects an object as soon as the door has stopped closing. Simply allow the doors to begin closing, and step in behind the doors, into the Bodyguards field of detection (be sure to NOT break the path of the lockout safety beams, if so equipped). The red LED shall illuminate and remain on at the Bodyguard, and at the LO-21U, as soon as the door reaches the fully closed position, provided that an object remains in the Bodyguard's detection field.

TROUBLE-SHOOTING	PROBLEM	PROBABLE CAUSE	CORRECTIVE ACTION
	With the door closed, the RED LED does not come on upon Bodyguard detection.	No Power applied to the Brown (+) and Orange (-) wires. Or The Gray and Violet wires are not properly connected to the Bodyguard pins 3,4.	Step 1. Check for power 12-24 VAC / 15-24 VDC on the Brown (+) and Orange (-) wires with a meter. If voltage is there go to Step 2. Step 2. Jumper across Bodyguard connector pins 3,4. <ul style="list-style-type: none"> • RED LED does not come on, go to Step 3. • RED LED comes on, go to Step 4. **Step 3. Check continuity with a meter on the Orange, Brown, Violet and Gray wires from the back of the harness connector to the ends of the wire. Correct any problem connections. If no problem connections are found, replace LO21U. Step 4. Check Bodyguard Relay Mode function is set to 1. If OK replace Bodyguard.
	With the door closed, the GREEN LED comes on upon Bodyguard detection.	Dipswitch# 6 is in the wrong position.	Step 1. Check that Dipswitch# 6 is set correctly for the application. Step 2. Remove harness from lockout and re-install (this resets the LO21U). Step 3. Check motor voltage in door closed and open position. Call Technical support.
	With the door open, the GREEN LED does not come on upon Bodyguard detection.	Reversed polarity or no motor voltage on the RED and BLACK wires.	Step 1. Check Dipswitch# 6 is correct for application. **Step 2. Check RED and BLACK wire connections at the motor or source of door open voltage. Correct any problem connections. Step 3. Reverse RED and BLACK LO21U wires at the motor.
	No LED display on the LO21U or Bodyguard and door will not open.	Dipswitch# 7,8 are in the wrong position.	Step 1. Check Dipswitches# 7,8 for proper position for application. Step 2. Check control box connections for the Yellow, Green and Blue wires. ** Remove power from sensors and door control before performing these checks..

NOTE: Lockout Relay will not function correctly when power close function is enabled on the door control.

COMPANY CONTACT



Do not leave problems unresolved. If a satisfactory solution cannot be achieved after troubleshooting a problem, please call B.E.A., Inc. If you must wait for the following workday to call B.E.A., leave the door inoperable until satisfactory repairs can be made. Never sacrifice the safe operation of the automatic door or gate for an incomplete solution.

The following numbers can be called 24 hours a day, 7 days a week. For more information, visit www.beainc.com.

West: 1-888-419-2564 **Mid-West: 1-888-308-8843**
South-East: 1-800-407-4545 **North-East: 1-866-836-1863**
US and Canada: 1-866-249-7937 **Canada: 1-866-836-1863**